

The right choice for the ultimate yield!

LS ELECTRIC strives to maximize your profits in gratitude for choosing us as your partner.

# AC Variable Speed Drive

**LSLV-S300 series**

**Safety Manual**

**0.4-75kW [200V]**

**0.4-220kW [400V]**



## **Safety Instructions**

- Read this manual carefully before installing, wiring, operating, servicing or inspecting this equipment.
- Keep this manual within easy reach for quick reference.

**LS**<sup>→</sup>**ELECTRIC**

This operation manual is intended for users with basic knowledge of electricity and electric devices.

\* LSLV-S300 is the official name for S300.

 **Warning**

Installation, commissioning, and maintenance of safety functions should be carried out by a person familiar with the safety manual.

# Safety Information

Read and follow all safety instructions in this manual precisely to avoid unsafe operating conditions, property damage, personal injury, or even death.

## Safety symbols in This Manual

### Danger

Indicates an imminently hazardous situation which, if not avoided, will result in severe injury or even death.

### Warning

Indicates a potentially hazardous situation which, if not avoided, could result in injury or even death.

### Caution

Indicates a potentially hazardous situation which, if not avoided, could result in minor injury or property damage.

## Safety Information

### Danger

- Never remove the product cover or touch the internal printed circuit board (PCB) or any contact points when the power is on. Also, do not start the product when the cover is open. This may cause an electrical shock due to the exposure of high voltage terminals or live parts.
- Even if the power is off, do not open the cover unless it is absolutely necessary like for the wiring operation or for regular inspection. Opening the cover may still cause an electrical shock even after the power is blocked because the product has been charged for a long period of time.
- Wait at least 10 minutes before opening the covers and exposing the terminal connections. Before starting work on the inverter, test the connections to ensure all DC voltage has been fully discharged. Otherwise it may cause an electrical shock and result in personal injury or even death.

### Warning

- Make sure to install ground connection between the equipment and the motor for safe use. Otherwise it may cause an electrical shock and result in personal injury or even death.
- Do not turn on the power if the product is damaged or faulty. If you find that the product is faulty, disconnect the power supply and have the product professionally repaired.
- The inverter becomes hot during operation. Avoid touching the inverter until it has cooled to avoid burns.
- Do not allow foreign objects, such as screws, metal chips, debris, water, or oil to get inside the inverter. Allowing foreign objects inside the inverter may cause the inverter to malfunction or result in a fire.
- Do not operate the switch with wet hands. Otherwise it may cause an electrical shock and result in personal injury or even death.
- Check the information about the protection level for the circuits and devices.

The connection terminals and parts below have electrical protection class 0. This means that the protection class of the circuit depends on basic insulation and there is a danger of electric shock if the basic insulation is not working properly. Therefore, take the same protective measures as handling the power line when connecting wires to the terminals or the device below, or when installing or using the devices.

- Multi-function Input: DI1–DI8, CM, DP/DG
  - Analog Input/Output: VR+/VR-, AI1/AI2/AI3, AO1/AO2, 5G
  - Pulse Train Input/Output: TI/TO
  - External 24V input: EPI
  - Digital Output: DA1/DB1/DC1, DA2/DC2, DQ3/EG
  - Safety: SA/SB/SP
  - Communication: S+/ S-
  - Fan
- The protection level of this equipment is electrical protective class 1.

### Caution

- Do not change the inside of the product at your own discretion. This may result in injury or damage to the product due to failure or malfunction. Also, products changed at your own discretion will be excluded from the product warranty.
- Do not use the inverter for single phase motor operation as it has been designed for three phase motor operation. Using a single phase motor may damage the motor.
- Do not place heavy objects on top of electric cables. Heavy objects may damage the cable and result in electric shock.



# Table of contents

<b>1</b>	<b>Description .....</b>	<b>1</b>
<b>2</b>	<b>Wiring .....</b>	<b>2</b>
	<b>Connection.....</b>	<b>3</b>
	<b>Wiring example .....</b>	<b>4</b>
	<b>Activation switch .....</b>	<b>6</b>
	<b>Cable type and lengths .....</b>	<b>6</b>
	<b>Grounding of protective shields.....</b>	<b>6</b>
<b>3</b>	<b>Operation principle .....</b>	<b>7</b>
<b>4</b>	<b>Test Run .....</b>	<b>8</b>
	<b>Acceptance test procedure .....</b>	<b>9</b>
<b>5</b>	<b>Use .....</b>	<b>10</b>
	<b>Limitations of STO function .....</b>	<b>12</b>
	<b>Residual risk.....</b>	<b>12</b>
<b>6</b>	<b>Trouble shooting .....</b>	<b>13</b>
<b>7</b>	<b>Maintenance.....</b>	<b>14</b>
<b>8</b>	<b>Fault tracing .....</b>	<b>16</b>
<b>9</b>	<b>Safety DATA.....</b>	<b>16</b>
	<b>Abbreviations.....</b>	<b>17</b>

---

Table of contents



# 1 Description

The Safety Torque Off (STO) function can be used to construct a safety circuit that stops the drive in a critical situation. It also has an advantage in maintenance as it can prevent the operation of the driving device without shutting off the power of the electrical appliance.

When the STO function is enabled, the control voltage at the power semiconductor is disabled and thus the torque required for motor rotation is not generated. When the motor is running, if the STO function is enabled, it transitions to a free-run stop state.

The STO function has a redundant structure, and both channels must be used for functional safety. The safety data given in this manual applies to redundant signals and is not valid if neither channel is in use.

The STO function complies with the following standard.

Standard	Name
EN 61508-1:2010	<i>Functional safety of electrical/electronic/programmable electronic safety-related systems – Part 1: General requirements</i>
EN 61508-2:2010	<i>Functional safety of electrical/electronic/programmable electronic safety-related systems – Part 2: Requirements for electrical/electronic/programmable electronic safety-related systems</i>
EN 61800-5-2:2007	<i>Adjustable speed electrical power drive systems – Part 5-2: Safety requirements – Functional</i>
EN 61800-5-2:2017	<i>Adjustable speed electrical power drive systems – Part 5-2: Safety requirements – Functional</i>
EN ISO 13849-1:2023	<i>Safety of machinery – Safety-related parts of control systems – Part 1: General principles for design</i>

## 2 Wiring

The following shows the placement of STO Input terminals in the control PCB. Refer to the detailed description to accurately understand the location and functionality of each terminal before performing the wiring operation.

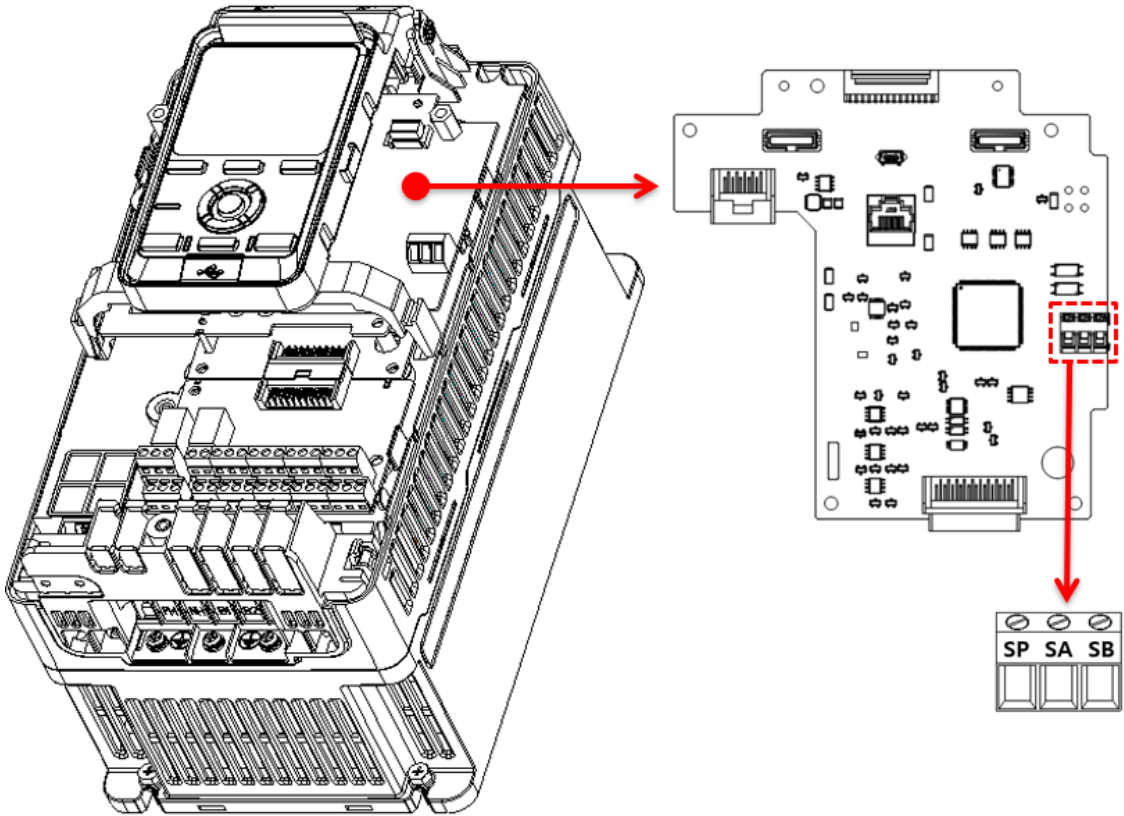

### STO signal input terminal symbol and description

Terminal symbol	Name	Cable spec.	Description
SA	Safety signal input terminal A	22~14 AWG 0.33~2.0 mm2	In the event of an emergency, the output is cut off based on the input signal. <ul style="list-style-type: none"> <li>• If both SA and SB are connected to the</li> </ul>

Terminal symbol	Name	Cable spec.	Description
SB	Safety signal input terminal B		SP: Normal operation • If either SA or SB is disconnected from the SP: Inverter output cut off
SP	Safety power source terminal		DC 24V, <25mA

## Connection

The STO function operates depending on the internal/external 24V voltage applied to the STO input terminal and stops by cutting off the drive control power of the power semiconductor element due to the operation of the internal circuit.

### Connections using an internal power source

Input of SA, SB terminal power is connected to internal 24V output of SP terminal. This connection is controlled by external equipment.

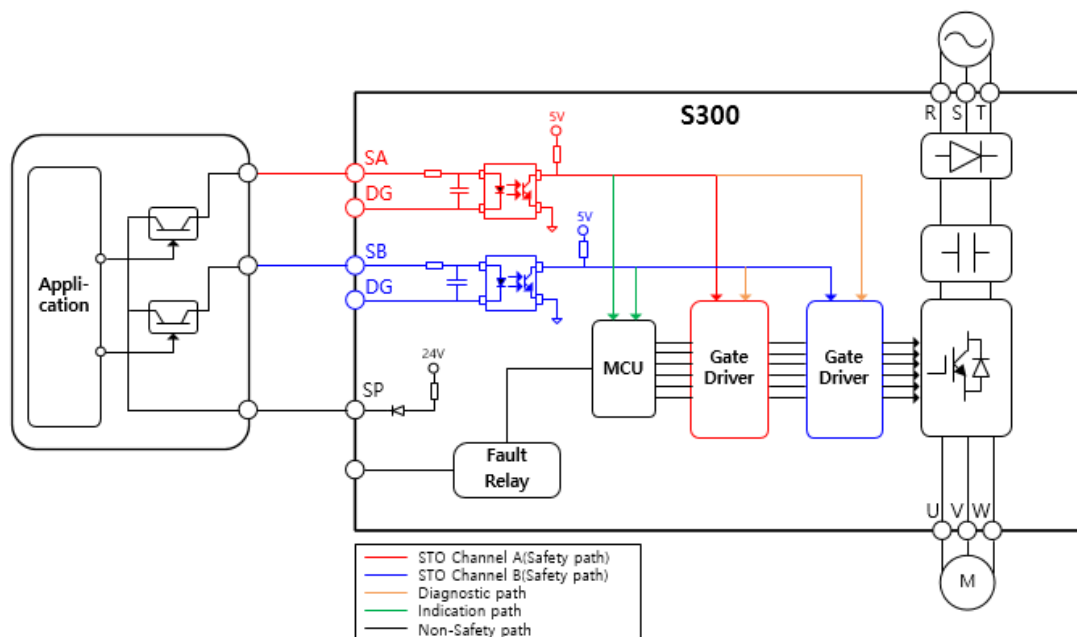

## Connections using an external power source

Input of SA, SB terminal power is connected to external 24V voltage source. This connection is controlled by external equipment.

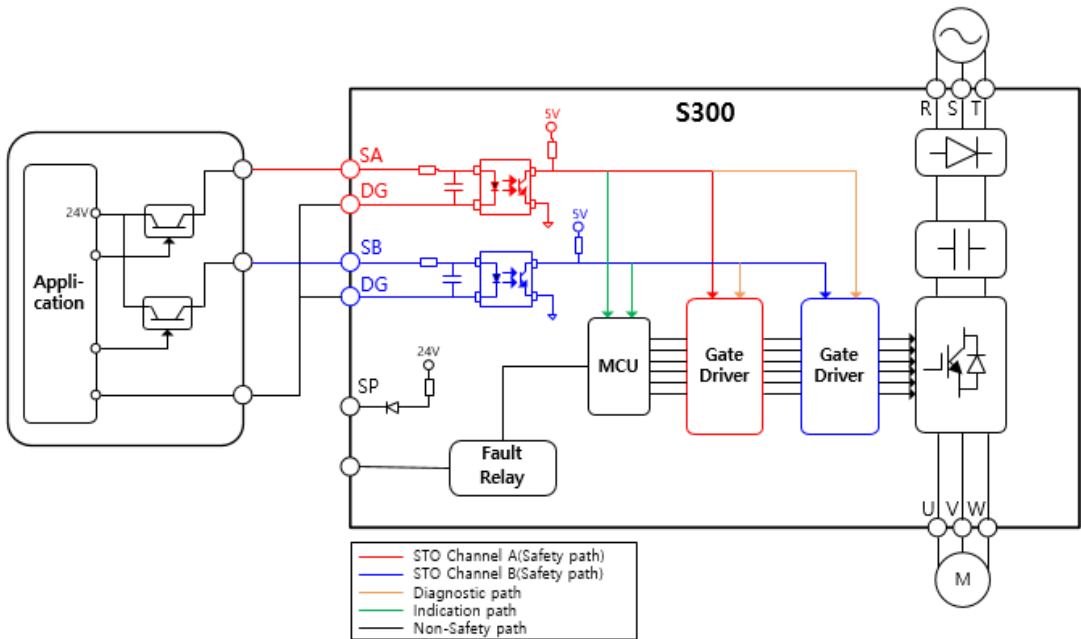

## Wiring example

Examples of STO Wiring with Internal power source

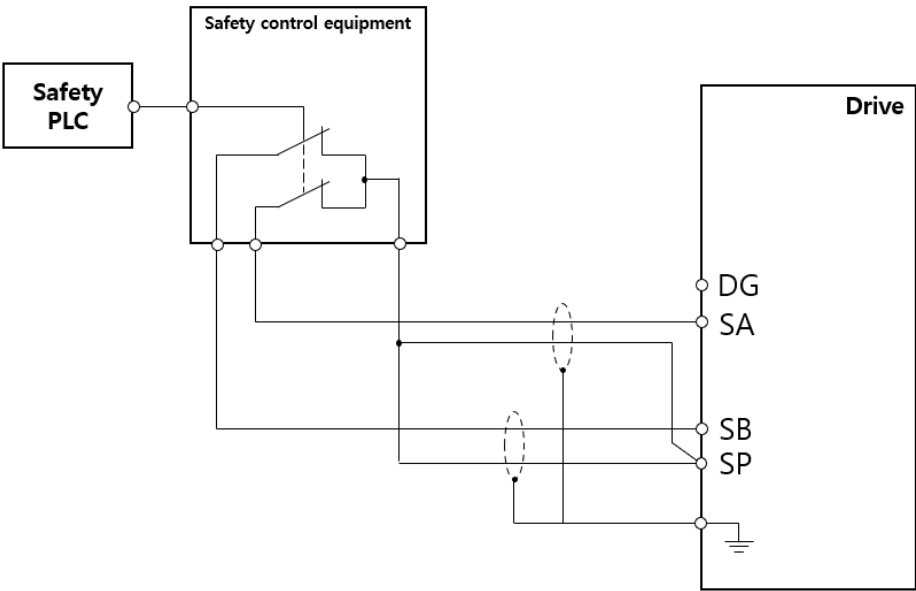

**Examples of STO Wiring with external power source**

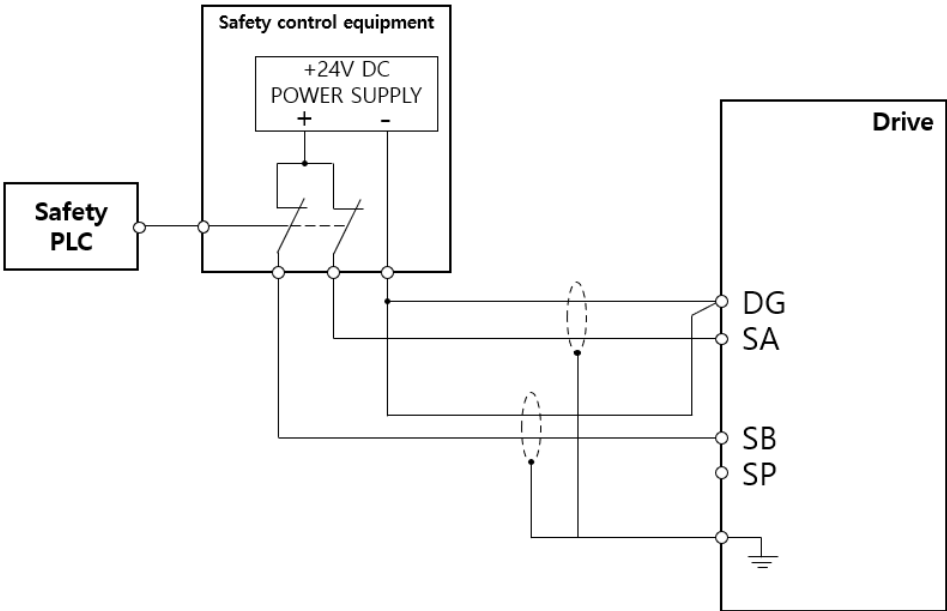

### **Activation switch**

The activation switch represents an emergency stop push button switch, or component such as a contactor of a safety relay or a safety PLC.

- If a manually operated switch is used, it must be normally closed contact.
- The open/close signal must operate within 20ms from switch operation to drive input.

### **Cable type and lengths**

STP(Shielded twisted pair cable) cable is recommended.

It is recommended that the wiring length between the activation switch and the drive control unit be within 30 m. When wiring more than 30m, it may be susceptible to noise so use ferrites for mitigation.

When supporting cables using cable ties, be careful not to apply the cable ties within 6 inches of the inverter. Otherwise, the front cover may not be assembled.

### **Grounding of protective shields**

Ground the shield in the cabling between the activation switch and the control board.

## 3 Operation principle

1. STO activates (activation switch or safety relay contacts open)
2. STO input on the drive control board is disabled.
3. Cut off the control voltage that drive IGBTs.
4. The control program generates a trip indication.

\*Trip indication does not affect STO function operation. If one or both STO signals are removed, the inverter drive stops. And it will not start until both STO signals are restored and all faults are reset.

5. The motor stops free run. The drive cannot be restarted when the activation switch or safety relay is open. It can be started when it is closed.

# 4 Test Run

### Warning

Commissioning of this product should be carried out by a qualified electrician. Otherwise it may cause an electrical shock and result in personal injury or even death. The safety instructions must be followed during the commissioning.

### Warning

Before starting the system for the first time, refer to Chapter 2.3 (Post-installation Checklist) of the S300 User's Manual to ensure it is properly installed.

Verification is required to check that the safety function is operating normally. The final assembler of the machinery must test and verify. The acceptance test must be performed.

- at initial start-up of the safety function
- after any changes related to the safety function (circuit boards, wiring, components, settings, etc.)
- after any maintenance work related to the safety function.

## Authorized person

Verification tests of safety functions should be conducted by persons with sufficient expertise in safety functions. Test procedures and reports must be documented and signed by an authorized person.

## Acceptance test reports

The signed acceptance test report must be kept in the machine's logbook. Reports should include documenting startup activities and test results, referencing fault reports and troubleshooting. New validation tests performed due to changes or maintenance should also be recorded in the logbook.

## Acceptance test procedure

After wiring the STO, validate its operation as follows.

<b>Action</b>	<input checked="" type="checkbox"/>
Ensure that the drive is free to run and stop during start-up.	<input type="checkbox"/>
Stop the drive (if running), turn off the input power and disconnect the drive from the power line.	<input type="checkbox"/>
Check the STO circuit connections against the wiring diagrams.	<input type="checkbox"/>
Close the separator and turn on the power	<input type="checkbox"/>
<p>Test the operation of the STO function when the motor is stopped.</p> <ul style="list-style-type: none"> <li>• Give the drive a stop command (if in operation) and wait for the motor shaft to stop. Verify that the drive works as follows:</li> <li>• Open the STO circuit. The inverter generates an STO trip and 'STO Feedback A' or 'STO Feedback B' Trip message is displayed on the keypad. Refer to the Trouble shooting chapter for a description of the warning.</li> <li>• Verify that the STO function blocks the operation of the inverter by commanding run. The inverter displays a warning, the motor must not start.</li> <li>• Close the STO circuit.</li> <li>• Reset the trip. Restart the inverter to verify that the motor is operating normally.</li> </ul>	<input type="checkbox"/>
<p>Test the operation of the STO function when the motor is running.</p> <ul style="list-style-type: none"> <li>• Give the drive a run and check the motor is running.</li> <li>• Open the STO circuit. The motor must stop. The inverter generates an STO trip and 'STO Feedback A' or 'STO Feedback B' Trip message is displayed on the keypad. Refer to the Trouble shooting chapter for a description of the warning.</li> <li>• Reset the trip and try to start the drive.</li> <li>• Verify that the trip is not reset and the drive is not working.</li> <li>• Close the STO circuit.</li> <li>• Reset the trip. Restart the inverter to verify that the motor is operating normally.</li> </ul>	<input type="checkbox"/>
Document and sign the Acceptance test report to ensure that the safety function is safe and accepted for operation	<input type="checkbox"/>

## 5 Use

1. Open the activation switch or activate the safety function wired to the STO connection.
2. If the STO input on the drive control is disabled, the IGBT drive control voltage is cut off.
3. The control program generates a trip and is indicated by keypad.
4. If the motor is running, it will go into a free run stop; the drive will not restart while the activation switch or safety relay contacts are open.
5. Disable by closing the activation switch or resetting the safety function connected to the STO connection.
6. Reset the trip on the inverter before restarting.

\*The STO function has a higher priority than all other functions on the drive.

In the S300 series, the STO function consists of two independent channels, STO\_A and STO\_B, and when one or both channel is activated, the motor drive gate signal is cut off to cut off the power to the motor. When the motor power is cut off, the output torque is cut off, the motor is free-run and the keypad displays the ' STO Feedback A ' or ' STO Feedback B ' Trip message depending on the operating channel.

For STO function on/off, the short bar mounted on the SA, SB, SP terminals must be removed. With SA, SB connected to the SP(24V) or external 24V power supply, the motor drive is normally operated with the STO function disabled. If the SP(24V) is disconnected or the external 24V power is disconnected, the STO function is activated. If you want to release from the STO function activation, reconnect SA, SB to the SP (24V) or an external 24V voltage source. Restart is only available after all trips are cleared.

Refer to the Action logic and Timing diagram below for the operation status according to the input.

### Safety function action logic

Connection state		Driving availability	Keypad display
SA-SP	SB-SP		
Short	Short	O	Command

			Frequency
Open	Short	X	STO Feedback A
Short	Open	X	STO Feedback B
Open	Open	X	STO Feedback A STO Feedback B

### Safety function timing diagram

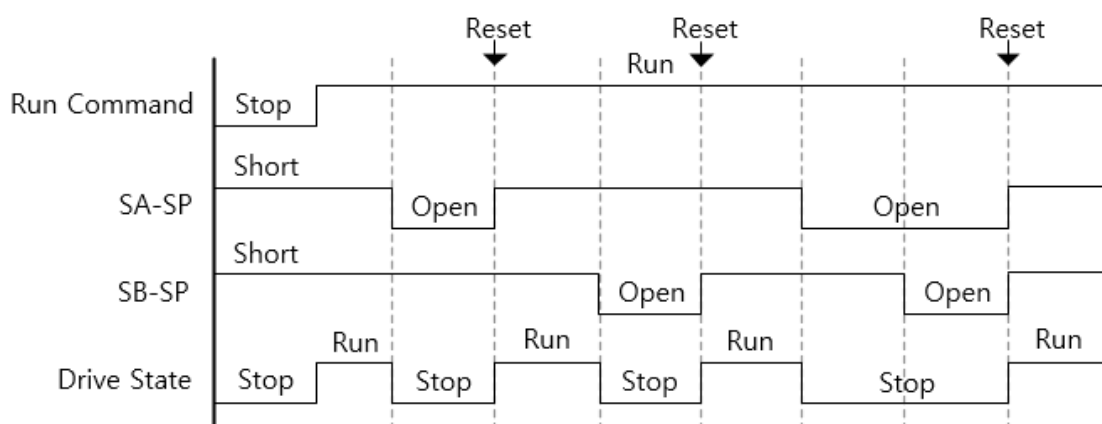

### Clearing Safety trip

Safety trip activation mode could be latch or level according to PRT-82 setting. If PRT-82 is set to "0", then safety trip will be latch mode. In this mode press STOP/RESET button on the keypad to clear safety trip. Under level mode safety trip will be cleared without pressing STOP/RESET button after STO activation input back to normal. Never set PRT-82 to level mode if there is a possibility of an emergency happening before restarting.

Group	Code	LCD Display	Setting		Setting Range	Factory setting	Unit
PRT	82	Safety Trip Mode	0	Latch	0~1	0	-
			1	Level			

#### Warning

Never set PRT-82 to level mode if there is a possibility of an emergency happening before restarting.

## Limitations of STO function

If the drive is stopped using the STO function, the drive cuts off the voltage supply to the motor and the motor stops free run. If this creates a risk or is not allowed, please stop the drive using the appropriate stop mode before activating the STO function.

When the motor stops free run, it will not stop and will maintain its rotation if the load's inertia is large or external force is applied. If you want to stop in the free run state, appropriate measures such as brakes are required.

The STO function is used to reduce the recognized risk condition, not all potential risks can be eliminated. The assembler of the machinery must inform the end user about any residual risks.

## Residual risk

Data on the failure rate is provided for the STO function only and results obtained from risk analysis and failure mode analysis. Additional safety measures must be taken against risks caused by mechanical and external factors.

### Warning

Use of inverter in vertical load system:

For systems like lifts or elevators where gravity always acts, it is necessary to have a brake system that can prevent the motor from rotating when the inverter is in a stopped state.

If the STO function of the inverter operates without a brake system, there is a risk of a fall because it does not supply any energy to the motor.

## 6 Trouble shooting

This chapter explains how to troubleshoot issues if a trip or hardware fault related to the STO function occurs. If the inverter does not work normally after following the suggested troubleshooting steps, please contact the LS ELECTRIC customer service center.

STO function has two channels: channel A and channel B, and when the STO function is activated, each channel independently generates a trip.

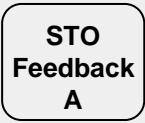
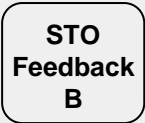
Keypad display	Name	Trip state	Discription
	STO_A Trip	Latch/Level	This trip occurs when the STO_A channel is active.
	STO_B Trip	Latch/Level	This trip occurs when the STO_B channel is active.

Case1. STO\_A or STO\_B trip occurs on STO request: Normal

Case2. STO\_A or STO\_B trip occurs without STO request: Bad wiring at safety input terminal or Hardware fault detection.

If the same symptom is repeated, please contact the LS ELECTRIC customer service center.

## 7 Maintenance

### Warning

Maintenance of this product should be carried out by a qualified electrician. Otherwise, it may cause an electrical shock and result in personal injury or even death.

### Warning

STO function does not cut off voltage supply of the internal circuit of the drive. Only the buffer signal is blocked to stop the switching of the IGBT. Therefore, maintenance work on all electrical parts of the system should be carried out after the power is shut off, and appropriate insulation procedures must be followed to ensure that the maintained parts of the system are insulated.

After the circuit operation verification during Test Run, regular validation tests for the STO function is needed. In the high demand mode of operation, the maximum interval for validation testing is 20 years, while in the low demand mode of operation, the maximum interval is 2 years. Please refer to the 'Acceptance test procedure' section for the test procedure.

### Diagnostic test interval

The individual in charge of designing the entire safety function should also consider the requirements specified in IEC 61800-5-2:2016 / EN 61800-5-2:2017 for the STO circuit of the drives.

- Diagnostic test interval when the hardware fault tolerance is greater than zero:  
one test per year for SIL 2, PL d / category 3
- Diagnostic test interval when the hardware fault tolerance is zero:

The diagnostic test interval of any subsystem of a PDS(SR) having a hardware fault tolerance of zero, on which a safety sub-function is entirely dependent, shall be such that the sum of the diagnostic test interval and the time to perform the specified action (fault reaction function) to achieve or maintain a safe state is less than the process safety time.

It is recommended that STO functional testing be included in the periodic maintenance program of the machine on which the drive operates.

If wiring or component changes are required after Test Run, follow the tests provided in the 'Acceptance test procedure' section.

Record all maintenance and validation test history in the logbook.

## 8 Fault tracing

Diagnostics of the STO function cross-comparisons the status of the two STO channels. STO trip occurs if the channel is not in the same state. For example, an STO trip occurs even if only one channel is activated. For more information about the trip, see the 'Operation Principle' section.

## 9 Safety DATA

The safety data for the STO function is given as follows.

Parameter	Value
Safety Function (EN 61800-5-2)	STO (Safe torque off)
SIL level	SIL2
Operating mode	High demand
PFH	$1.3699 \times 10^{-9}$
Subsystem Type	Type A
SFF(%)	Subsystem A/B: 81.1% Subsystem PS/VM: 80.1%
HFT	Subsystem A/B: 1 Subsystem PS/VM: 0
EN ISO 13849	Category 3, PL d
MTTFd	High(100year)
DC	Low
SC	2
STO response time*	20ms
Mission time	20 years

\* STO response time: Time from STO activation signal to buffer cutoff signal.

### Hardware failure information

Relevant failure modes

- Unintended STO Trip
- Not active when STO required (dangerous failure)

Several diagnostics are implemented to detect hardware failures in the safety function circuit. Diagnostics are performed periodically after power is applied, and if a

hardware fault is detected, the STO function is activated.

If there is no response when a failure occurs under the diagnostic system among any hardware failures, it is defined as 'undetected dangerous failure'. When the Mission time of the safety function circuit is 20 years, the failure rate information is presented in the following table.

	$\lambda_s$ [FIT]	$\lambda_d$ [FIT]	$\lambda_{dd}$ [FIT]	$\lambda_{du}$ [FIT]
Subsystem A/B	3.51	9.87	7.35	2.53
Subsystem PS/VM	14.99	24.31	16.52	1.32

This analysis assumes that one failure occurs at a time; the accumulated failure was not analyzed.

## Abbreviations

Abbr.	Reference	Description
DC	EN ISO 13849-1	Diagnostic coverage
FIT	EN 61508	Failure in time: 1E-9 hours
HFT	EN 61508	Hardware fault tolerance
MTTF <sub>d</sub>	EN ISO 13849-1	Mean time to dangerous failure: (The total number of life units) / (the number of dangerous, undetected failures) during a particular measurement interval under stated conditions
PFH	EN 61508	Probability of dangerous failures per hour
PL	EN ISO 13849-1	Performance level. Levels a...e correspond to SIL
SC	EN 61508	Systematic capability
SFF	EN 61508	Safe failure fraction (%)
SIL	EN 61508	Safety integrity level (1...3)
STO	EN 61800-5-2	Safe torque off
$\lambda_s$	EN 61508	Safe failure rate
$\lambda_D$	EN 61508	Dangerous failure rate
$\lambda_{Dd}$	EN 61508	Detected dangerous failure rate
$\lambda_{Du}$	EN 61508	Undetected dangerous failure rate

## Responsibilities

As an inverter manufacturer, LS ELECTRIC is only responsible for the safety and

suitability of the individual inverter product, rather than the system in which the product is used. Furthermore, if the product is disassembled or modified arbitrarily, we do not warranty the product. If errors are found in the product's safety functions, please contact your local LS ELECTRIC representative.

# EC DECLARATION OF CONFORMITY

We, the undersigned,

Manufacturer: **LS ELECTRIC Co., Ltd.**  
Address: **LS Tower, 127, LS-ro, Dongan-gu,  
Anyang-si, Gyeonggi-do, Korea**

**Certify and declare under our sole responsibility that the following products:**

Type of Equipment: **The safety function safe torque off(STO) within  
the LSLV S300 series**  
Model Name: **LSLV-S300 series**  
Trade Mark: **LS ELECTRIC Co., Ltd.**

**Conforms to the essential health and safety requirements of the directive:**

2006/42/EC of the European Parliament and of the Council of 17 May 2006 on  
machinery, and amending directive 95/16/EC.

**Based on the following standards applied:**

**EN 61800-5-2:2007**  
**EN ISO 13849-1:2023**  
**EN IEC 61508:2010**

The EC type-examination, complying with Annex IX of Directive 2006/42/EC, has  
been carried out by:

Name	TÜV CYPRUS Ltd.
Address	2 Papaflessa Str., 2235 Latsia, Nicosia
Identification number	

**The party authorised to compile the technical file is:**

Hyeok Joong, Choi, LS Electric Europe B.V, Capellalaan 127, 2132JM, Netherlands

Place: **Cheonan, Chungnam, Korea**

박창근 2025.01.29

**Mr. PARK CHANGKEUN / Manager**  
**on behalf of LS ELECTRIC Co., Ltd.**



---

# Certificate

## UL mark

The UL mark applies to products in the United States and Canada. This mark indicates that UL has tested and evaluated the products and determined that the products satisfy the UL standards for product safety. If a product received UL certification, this means that all components inside the product had been certified for UL standards as well.

Suitable for Installation in a compartment Handling Conditioned Air.

## CE mark

The CE mark indicates that the products carrying this mark comply with European safety and environmental regulations. European standards include the Machinery Directive for machine manufacturers, the Low Voltage Directive for electronics manufacturers and the EMC directive for electrical equipment.

### **Low Voltage Directive**

We have confirmed that our products comply with the Low Voltage Directive (EN 61800-5-1).

### **EMC Directive**

The Directive defines the requirements for immunity and emissions of electrical equipment used within the European Union. The EMC product standard (EN 61800-3) covers requirements stated for drives.

## EAC mark

The EAC (EurAsian Conformity) mark is applied to the products before they are placed on the market of the Eurasian Customs Union member states. It indicates the compliance of the products with the following technical regulations and requirements of the Eurasian Customs Union:

- Technical Regulations of the Customs Union 004/2011 “On safety of low voltage equipment”
- Technical Regulations of the Customs Union 020/2011 “On electromagnetic compatibility of technical products”

# Manual Revision History

## Revision History

No	Date	Edition	Changes
1	2024.11.04	V0.0.1	-
2	2025.01.22	V0.0.2	Safety data update according to FMEDA revision

#### ■ Headquarter

LS-ro 127(Hogye-dong) Dongan-gu, Anyang-si, Gyeonggi-Do, 14119, Korea

#### ■ Seoul Office

LS Yongsan Tower, 92, Hangang-daero, Yongsan-gu, Seoul, 04386, Korea

Tel: 82-2-2034-4033, 4888, 4703 Fax: 82-2-2034-4588

E-mail: automation@lselectric.co.kr

#### ■ Overseas Subsidiaries

##### • LS ELECTRIC Japan Co., Ltd. (Tokyo, Japan)

Tel: 81-3-6268-8241 E-Mail: jschuna@lselectric.biz

##### • LS ELECTRIC (Dalian) Co., Ltd. (Dalian, China)

Tel: 86-411-8730-6495 E-Mail: jiheo@lselectric.com.cn

##### • LS ELECTRIC (Wuxi) Co., Ltd. (Wuxi, China)

Tel: 86-510-6851-6666 E-Mail: sblee@lselectric.co.kr

##### • LS ELECTRIC Vietnam Co., Ltd.

Tel: 84-93-631-4099 E-Mail: jhchoi4@lselectric.biz (Hanoi)

Tel: 84-28-3823-7890 E-Mail: sjbaik@lselectric.biz (Hochiminh)

##### • LS ELECTRIC Middle East FZE (Dubai, U.A.E.)

Tel: 971-4-886-5360 E-Mail: salesme@lselectric.biz

##### • LS ELECTRIC Europe B.V. (Hoofddorp, Netherlands)

Tel: 31-20-654-1424 E-Mail: europartner@lselectric.biz

##### • LS ELECTRIC America Inc. (Chicago, USA)

Tel: 1-800-891-2941 E-Mail: sales.us@lselectricamerica.com

#### ■ Overseas Branches

##### • LS ELECTRIC Tokyo Office (Japan)

Tel: 81-3-6268-8241 E-Mail: jschuna@lselectric.biz

##### • LS ELECTRIC Beijing Office (China)

Tel: 86-10-5095-1631 E-Mail: khpaek@lselectric.com.cn

##### • LS ELECTRIC Shanghai Office (China)

Tel: 86-21-5237-9977 E-Mail: tsjun@lselectric.com.cn

##### • LS ELECTRIC Guangzhou Office (China)

Tel: 86-20-3818-2883 E-Mail: chenxs@lselectric.com.cn

##### • LS ELECTRIC Chengdu Office (China)

Tel: 86-28-8670-3201 E-Mail: yangcf@lselectric.com.cn

##### • LS ELECTRIC Qingdao Office (China)

Tel: 86-532-8501-2065 E-Mail: wangzy@lselectric.com.cn

##### • LS ELECTRIC Nanjing Office (China)

Tel: 86-25-8467-0005 E-Mail: ylong@lselectric.com.cn

##### • LS ELECTRIC Bangkok Office (Thailand)

Tel: 66-90-950-9683 E-Mail: sjleet@lselectric.biz

##### • LS ELECTRIC Jakarta Office (Indonesia)

Tel: 62-21-2933-7614 E-Mail: dioh@lselectric.biz

##### • LS ELECTRIC Moscow Office (Russia)

Tel: 7-499-682-6130 E-Mail: jdpark1@lselectric.biz

##### • LS ELECTRIC America Western Office (Irvine, USA)

Tel: 1-949-333-3140 E-Mail: wyyun@lselectricamerica.com

#### Disclaimer of Liability

LS ELECTRIC has reviewed the information in this publication to ensure consistency with the hardware and software described.

However, LS ELECTRIC cannot guarantee full consistency, nor be responsible for any damages or compensation, since variance cannot be precluded entirely. Please check again the version of this publication before you use the product.

© LS ELECTRIC Co., Ltd 2020 All Right Reserved.

LSLV-S300 / 2024.11