

■ ReleaseNote - XG5000 V4.72

1. Error Correction

(1) XGI/XGR/XEC/XMC CPU malfunction when Label or SBRT(subroutine) is added through online editing

- When adding a [Label]/[SBRT] through online editing after [Open from PLC] in the PLC using the [Label], the CPU malfunctioned due to internal overlapping with the previously registered [Label] has been improved.

(2) Fix other errors

* XG5000 V4.72 is a version that has improved the above errors in the previous V4.71 version.

■ ReleaseNote - XG5000 V4.71

1. Improvements and additions

(1) Added [Continuous Paste] function

This is a function for pasting a large amount of the area copied to the clipboard in the LD editor.

[Step]

After executing copy function in LD, click XG5000 menu [Edit]-[Continuous Paste] or pop-up menu [Continuous Paste].

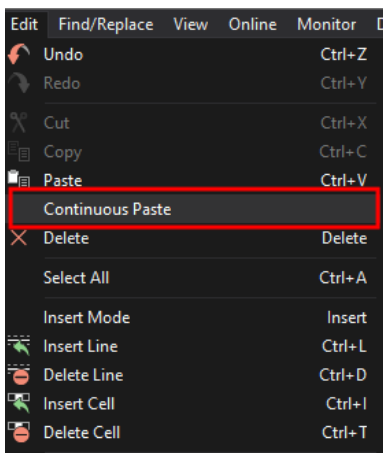

In the [Continuous Paste] setting window, set [Number of Continuous], [Paste Direction], and [Increment Value Setting] and click the [Execution] button. The increment value is copied to the variable name to be pasted, with the variable value increased by the increment value.

Increments can reflect the increments of copies in batches by selecting [Batch Reflection of Increments]. Alternatively, the increment value of that copy in the list can be set separately.

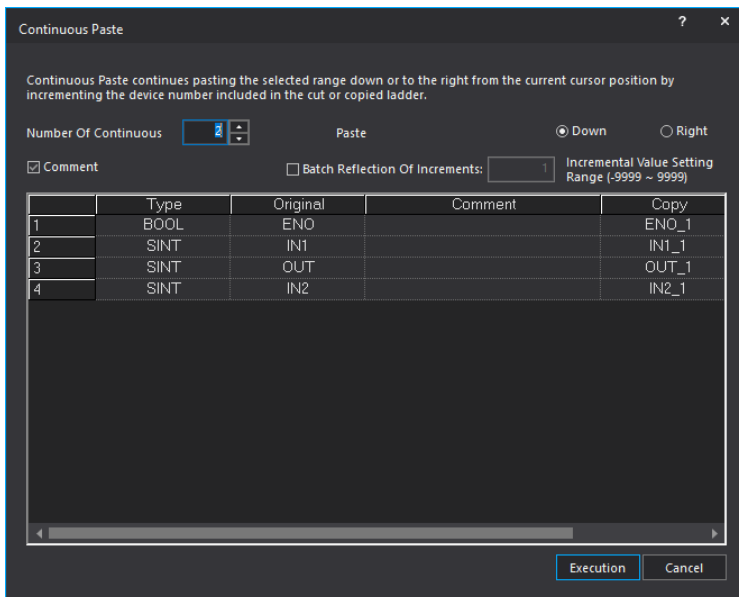

When you click [Execution] button, paste is executed as shown in the picture below and is automatically registered in the local variable.

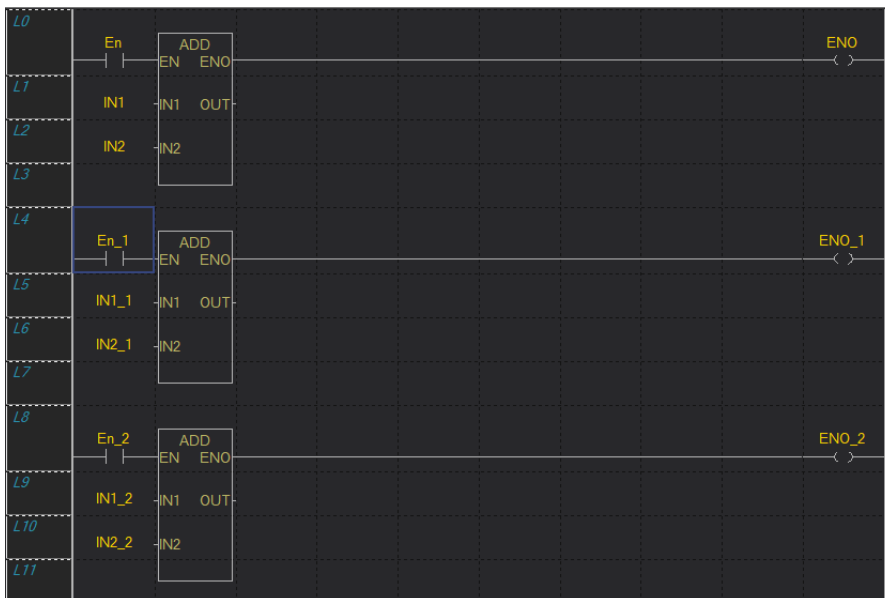
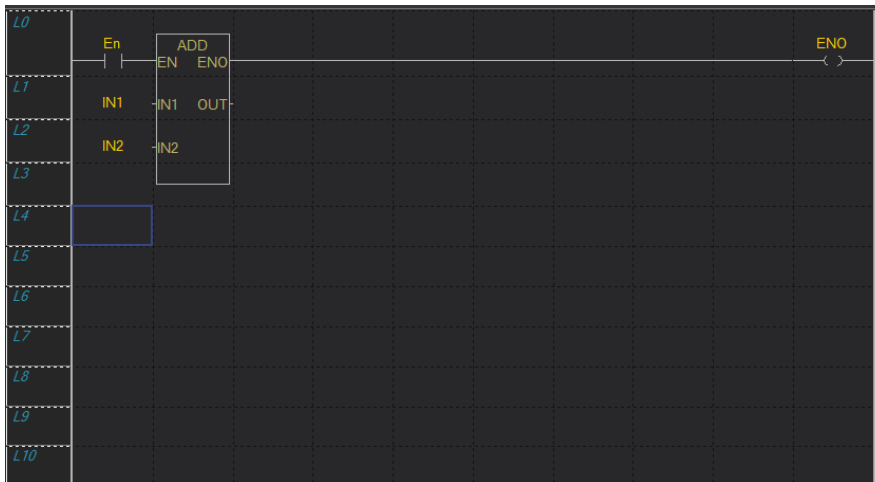

[Notice]

- * [Continuous Paste] function cannot exceed 65536 lines for bottom paste and 31 columns for right paste.
- * Copied blocks cannot be pasted beyond 100.
- * [Continuous Paste] is not applied to CPT function.
- * In case of direct variable, if it exceeds the direct variable area, it is displayed as '?' and is not executed.



(2) Improved LD drag & drop

It can be dragged and dropped by moving the mouse to the border of the selected cursor.

(3) Added [Renounce] function for Connection/Permission status

In CPUs that support multi-connection, the function to give up write permission has been added. It can be used when you want to monitor only without modifying the program. It is possible to change from the write permission mode to the read-only mode by using the [Renounce] button.

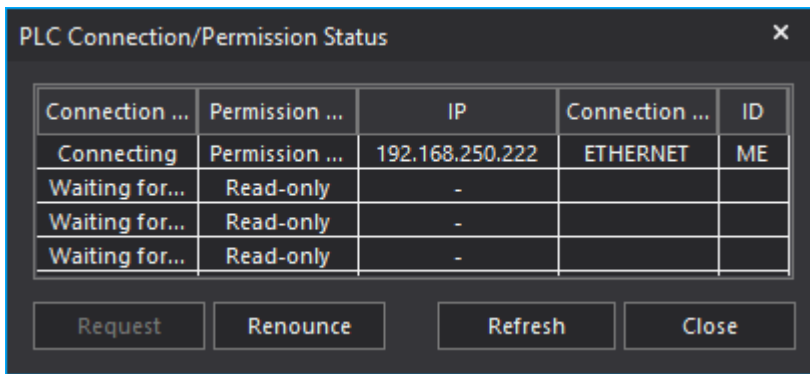

(4) Added XGB Renewal product

XGB Renewal products (XGB-XBCH, XGB-XECH type O/S version 5.0 or higher) have been added.

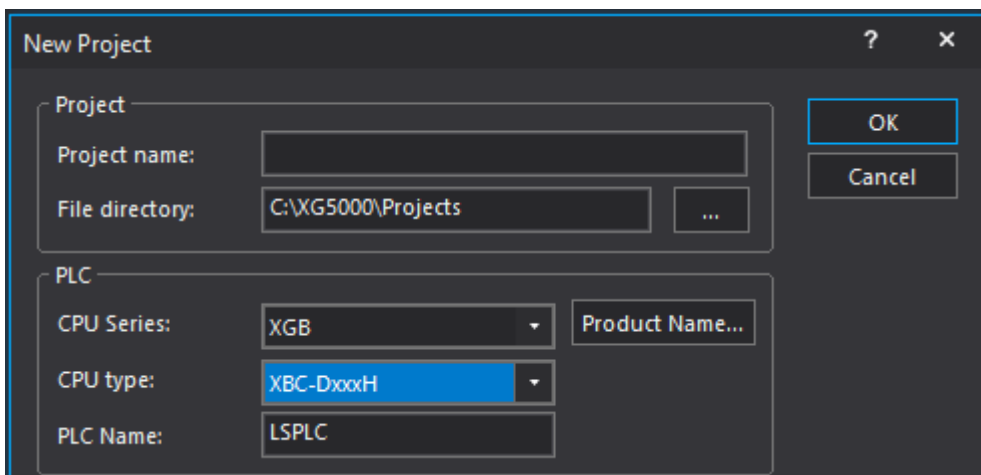

[Compatibility]

XGB-XECH CPU module needs attention in terms of compatibility as follows depending on O/S version. (XGB-XBCH has no restrictions)

In case of CPU O/S V5.00 or higher, XG5000 V4.71 or higher version must be used.

CPU O/S	Function	XG5000	
		Less than V4.71	V4.71 or higher
Less than V5.00	Read Program	○	○
	Monitor	○	○
	Write Program	○	○
	Online Editing	○	○
V5.00 or higher	Read Program	○	○
	Monitor	○	○
	Write Program	X(Not supported)	○
	Online Editing	X(Not supported)	○

If you try to write to an unsupported version, it will not complete normally. Please refer to the product user manual for details.

(5) Added [Sampling Mode] function related to XBF-TC04RT/XBF-TC04TT module in XG-TCON

This function is supported by XBF-TC04RT V1.9 or higher.

Parameter setting -New

Parameter	Type	LOOP0	LOOP1	LOOP2	LOOP3
Input type	<input type="checkbox"/> Input type	K: -200 ~ 1300 °C	K: -200 ~ 1300 °C	K: -200 ~ 1300 °C	K: -200 ~ 1300 °C
	<input type="checkbox"/> Short circuit	Permission	Permission	Permission	Permission
	Upper limit of effective input	1300.0	1300.0	1300.0	1300.0
	Lower limit of effective input	-200.0	-200.0	-200.0	-200.0
	Upper limit of scale	1300.0	1300.0	1300.0	1300.0
Input process	<input type="checkbox"/> Average type	Weighted average	Weighted average	Weighted average	Weighted average
	Average Value	0	0	0	0
Input alarm	High upper limit	1300.0	1300.0	1300.0	1300.0
	Upper limit	1300.0	1300.0	1300.0	1300.0
	Lower limit	-200.0	-200.0	-200.0	-200.0
	Low lower limit	-200.0	-200.0	-200.0	-200.0
Cold junction compensation	<input type="checkbox"/> Compensation method	Internal RJC	Internal RJC	Internal RJC	Internal RJC
	External RJC	0.0	0.0	0.0	0.0

Sampling Mode

High-Speed Mode (0.5s / 4loop)

High-Resolution Mode (2s / 4loop)

(6) Added input type related to XGF-TC4RT/XBF-TC04RT module in XG-TCON

Two types (Pt100: -200.00~300.00°C, Pt100: -200.00~100.00°C) have been added, and XGF-TC4RT supports V3.6 or higher and XBF-TC04RT supports V1.8 or higher.

(7) Improved XG-TCON trend monitor function

Improved to keep the graph when changing “Maximum Sample Display”.

When changing the graph color, the entire graph color is improved.

(8) EtherCAT Slave - Added user-selected SDO parameter editing function

Added a function to manage only the parameters selected by the user.

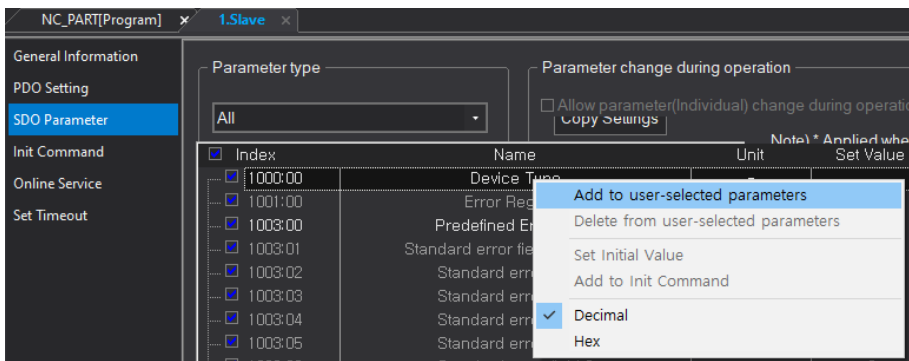

The user-selected parameters added by the user can be checked by selecting [User Selection] among the parameter types.

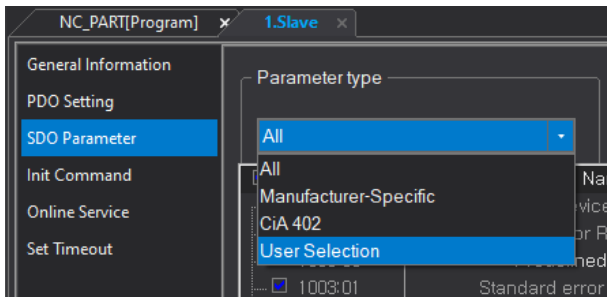

Only the SDO parameter selected in [EtherCAT Parameter] - [Master] - [SDO parameter read/write operation mode] option can be read/written.

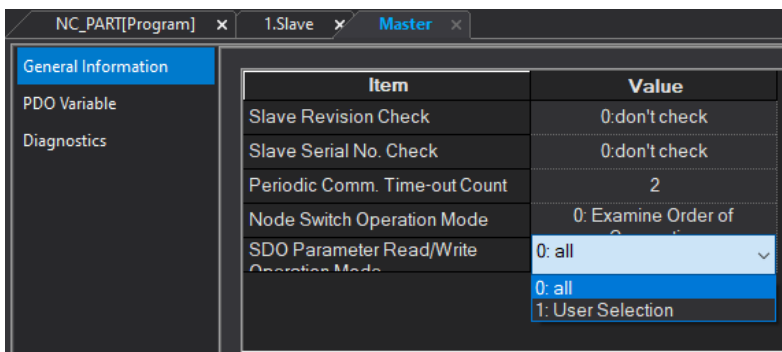

(9) Added copy function in [EtherCAT Slave] – [SDO parameter]

Added a function to copy the SDO parameter of the current slave to another slave.

In addition to all/manufacture specific/CiA 402 groups, user-selected parameters can also be copied.

The copy destination slave is limited to the same slave product.

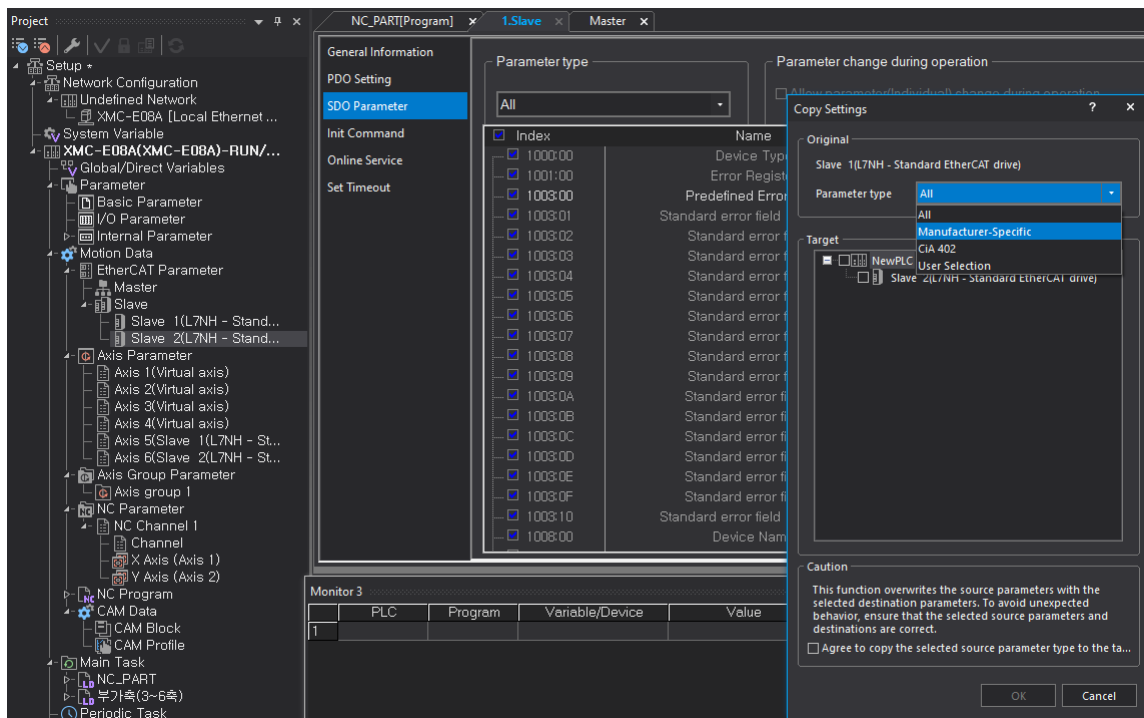

(10) [XG-PM] Added automatic project saving function when downloading program or online editing

- Added a function to restore a project lost due to unexpected termination of the application by adding a save option when downloading the program or modifying it during run.

- It can be set in [Tools] - [Options] - [XG-PM] - [Save the project when writing or modified program] option.

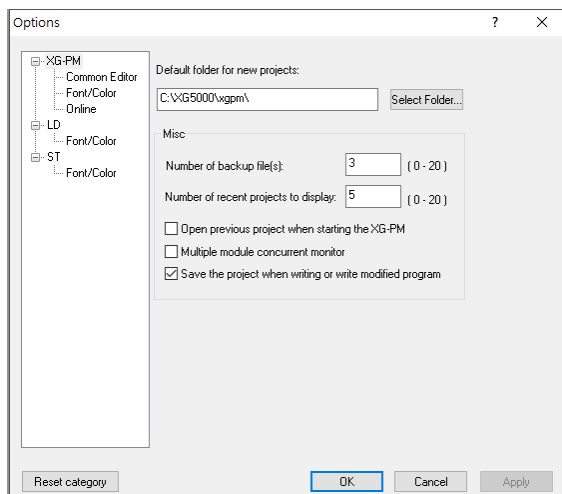

(11) Added command

The following commands have been added. For information on command operation and supported models, please refer to the manual.

XGI-CPUE XGI-CPUH XGI-CPUS XGI-CPUU	<ul style="list-style-type: none"> - INLATCH, - FCS - ADD_CAL, SUB_CAL - M_SET_IP, M_NET_INFO, M_GET_LED - GROUP_MOVE, GROUP_MOVE32, GROUP_FILL, GROUP_FILL32, GROUP_SCH, GROUP_SUM, GROUP_ROTATE, GROUP_SHIFT, GROUP_FIND, - ANY_MOVE, ANY_MOVE2, ANY_CMP, ANY_CMP_EQ, ANY_CMP_NE - ARY_SCH2 - CP_MSG - SET_DENTS_PARAM - TICK_CUR, TICK_ET - SIZEOF
XGI-CPUUN	<ul style="list-style-type: none"> - SIZEOF
XMC	<ul style="list-style-type: none"> - SET_IP, GET_IP - ADD_CAL, SUB_CAL - ARY_SCH2 - SIZEOF - ARY_MOVE32, ARY_FLL32
XGI-CPUZ	<ul style="list-style-type: none"> - SIZEOF - ARY_MOVE32, ARY_FLL32
XGB	<ul style="list-style-type: none"> - XGB L_NET_INFO ※ XGB: XBC-U(V2.20 or higher), XBM-H(V1.50 or higher), XBM-H2(V2.30 or higher), XBM-HP(V2.30 or higher) XGB(IEC): XEC-U(V2.20 or higher), XEM-H2(V2.30 or higher), XEM-HP(V2.30 or higher)

2. Error Correction

(1) [XG-PM] Ladder broken when reading from PLC

An upload operation error caused by a user function/function block update error has been corrected. When downloading the program, the user function/function block update is performed to correct the operation error caused by the mismatch between the general program and the user function/function block.

■ ReleaseNote - XG5000 V4.70

1. Improvements and additions

(1) Added XGI-CPUZ model

XGI-CPUZ3/5/7 models have been added. For detailed specifications of XGI-CPUZ3/5/7, refer to the XGI-CPUZ CPU user manual.

Item		XGI-CPUZ7	XGI-CPUZ5	XGI-CPUZ3
Operation Method		Main task/Cycle Task : fixed period and cyclic operation Initialization task :Only once at the time of entering the RUN		
Control cycle		Main Task Time : 1ms ~ 1,000ms (1ms unit setting) Cycle Task Time : Multiple setting of main task(2~4,000ms)		
Calculation processing speed (Basic Instructions)	Default(LD)	6.5 ns/command		
	MOVE	5.2 ns/command		
	Real calculation	±: 31 ns(S), 121 ns(D) x : 31 ns(S), 119 ns(D) ÷: 34 ns(S), 142 ns(D)		
Program memory	Capacity	10MB: sequence+motion 10MB: NC control	4MB: sequence+motion 5MB: NC control	2MB: sequence+motion 5MB: NC control
Motion Control	Real/Virtual Axes	Axis 32	Axis 16	Axis 8
	Dedicated Virtual Axis	Axis 4	Axis 2	Axis 1
	Slave (real axis)	64 Slave	32 Slave	16 Slave
External memory	Memory type	Micro SD/SDHC		
	File system	FAT32		
	Service	Program back-up/restoration, Booting operation		
Built-in communication port	USB Device	Loader service (XG5000)		
	USB Host	Supported devices: Wi-Fi Dongle		
	Wi-Fi	Web Server		
	Ethernet	Service setting in local Ethernet parameter of XG5000 XGT server - dedicated communication Third-party protocol support(MODBUS TCP server) FTP server NTP client Web Server Socket service (LS electric and third-party client service correspondence)		
Security		Project password TLS support: Loader service, Web Server, FTP server		

(2) Added dark theme function

For those who use the monitor for a long time, a dark theme function has been added. The theme can be set in the menu [Tools] – [Customize] – [Color]. Changed color theme will be applied after restarting the XG5000.

[Blue Theme]

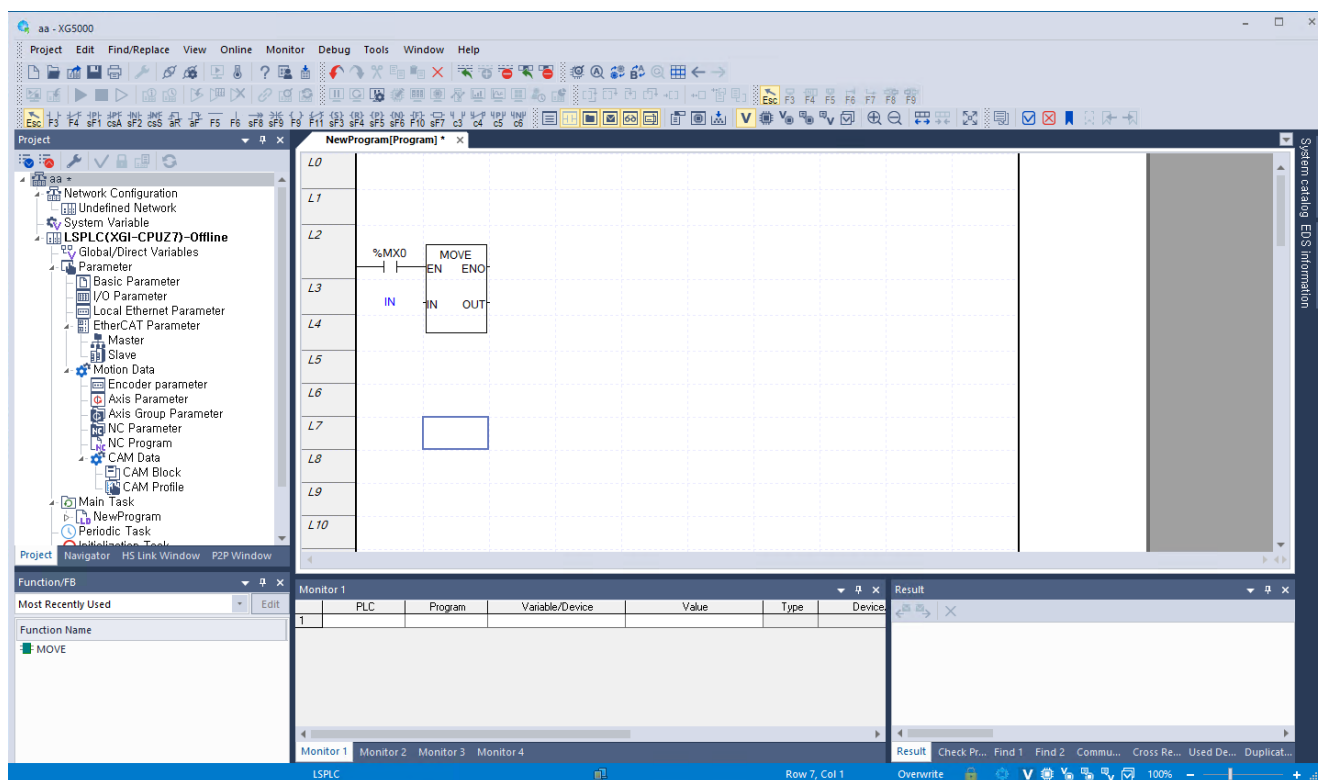
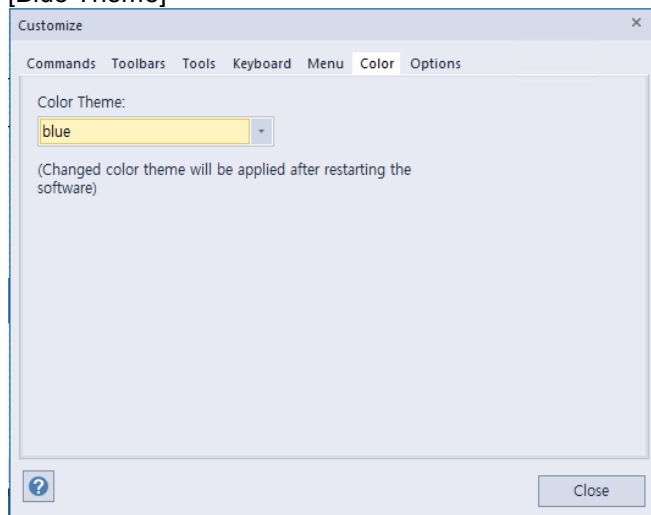

[Dark Theme]

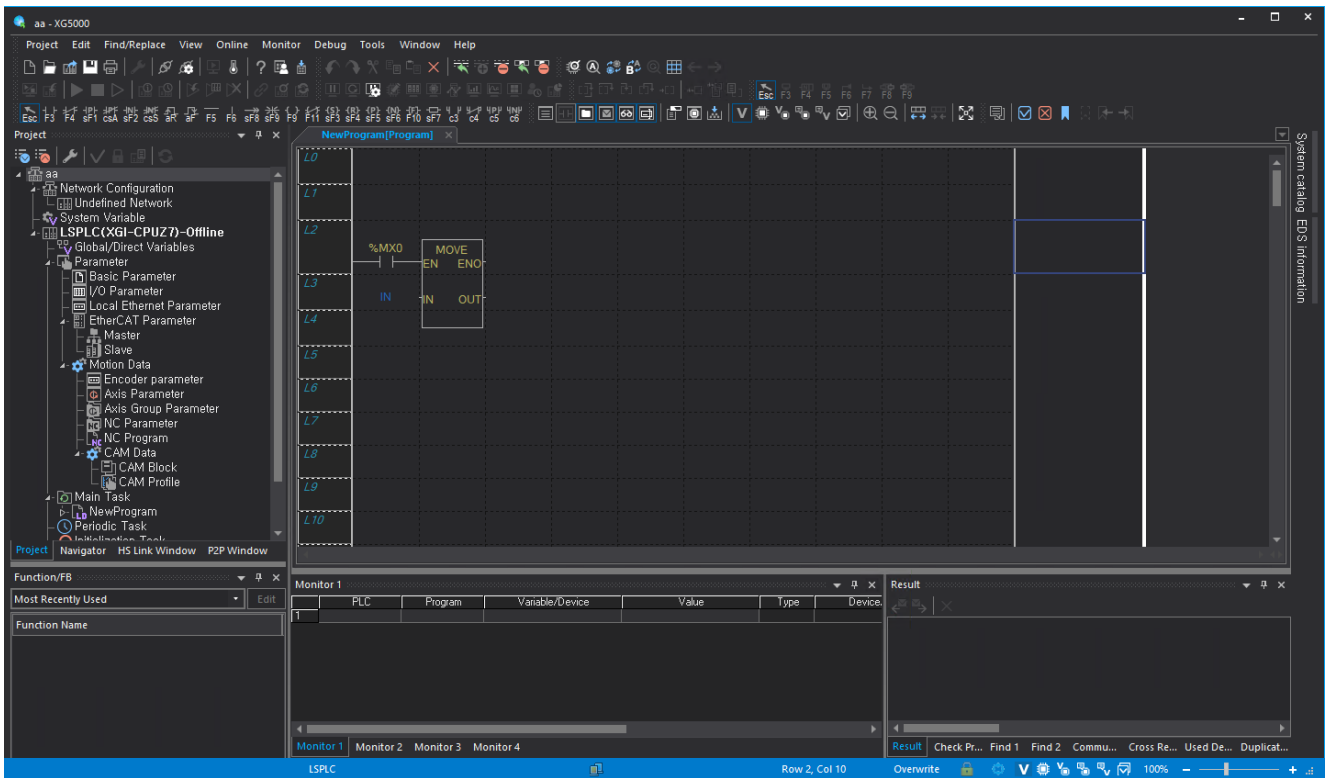
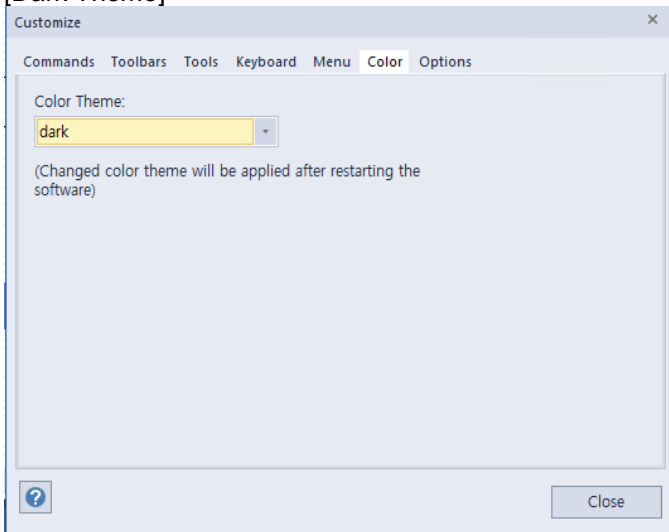

(3) Added frame capture function

Frame capture function has been added to XGL-EFMTB.

[Step]

1. Click [Communication Module Setting and Diagnosis] – [System Diagnosis].
2. Select Communication Module(XGL-EFMTB) - Run Context Menu
3. Click [View Communication Module Log].

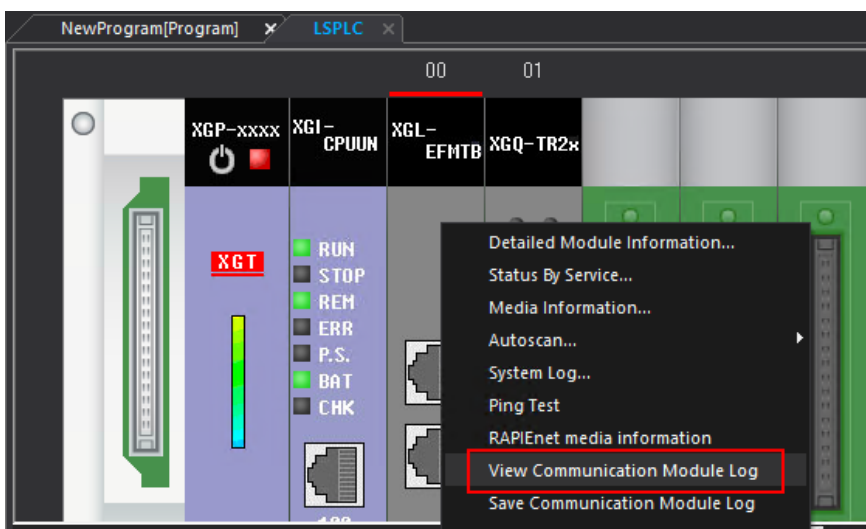

4. Select [Frame Log].

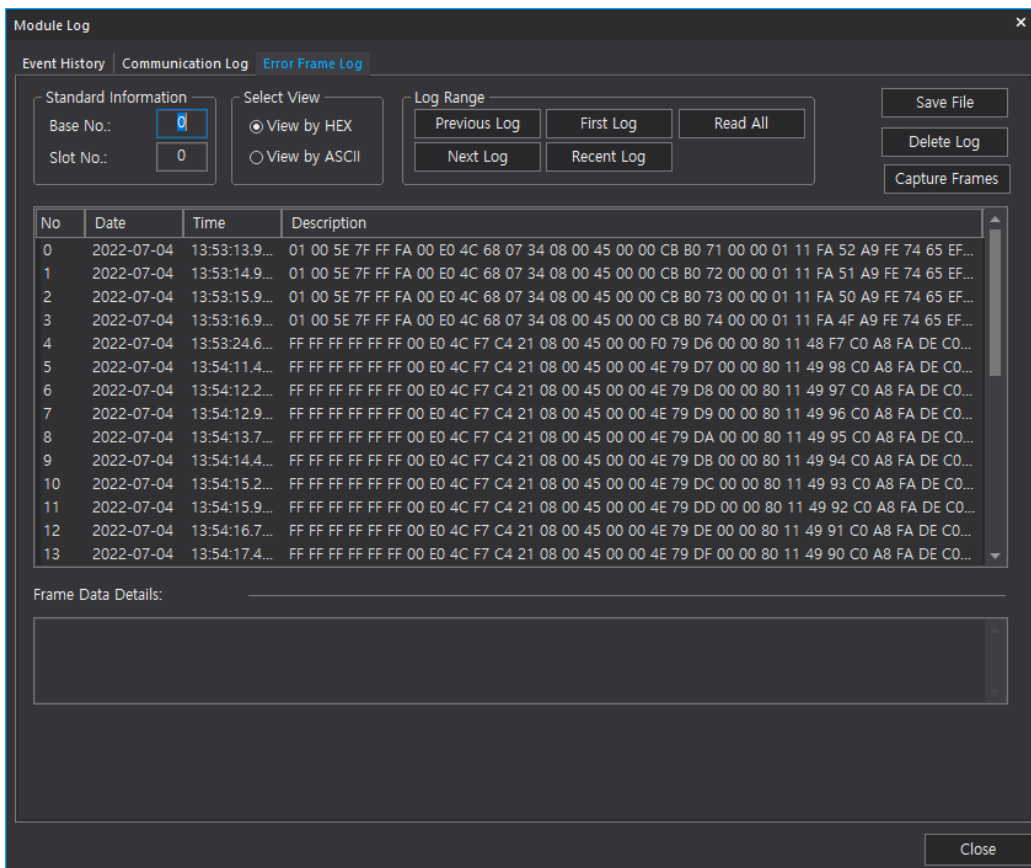

5. Click [Frame capture].

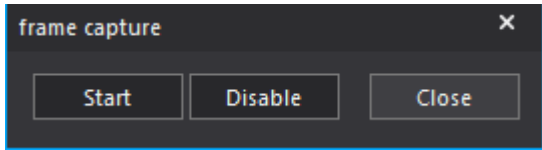

The captured file can also be checked in Wireshark.

[Step]

- (a) Save file button.
- (b) Execute [Wireshark].
- (c) Click [File] – [Import from Hex Dump].
- (d) Click the Browse button to select the saved txt file.

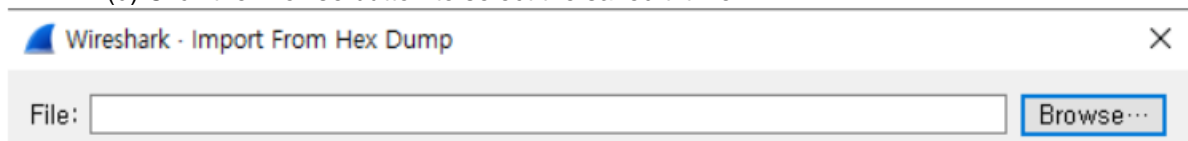

- (e) Click [Import].

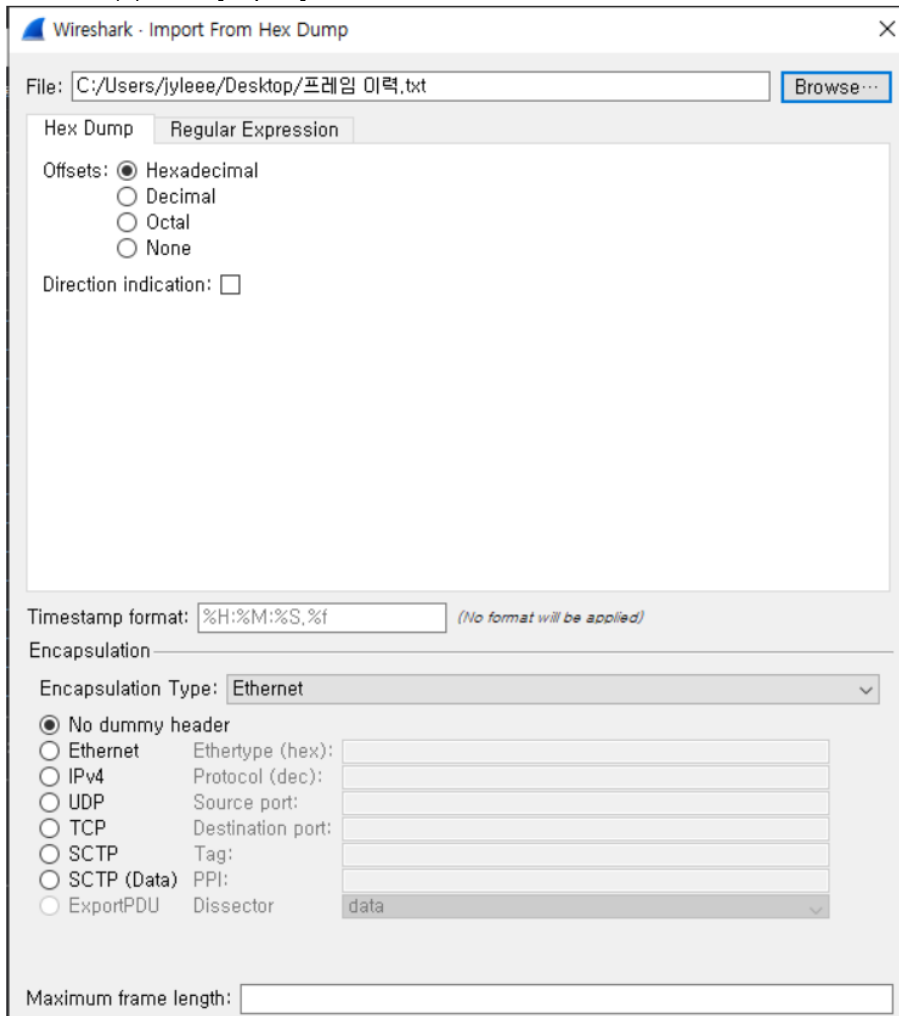

(f) The contents of the saved frame can be checked in Wireshark.

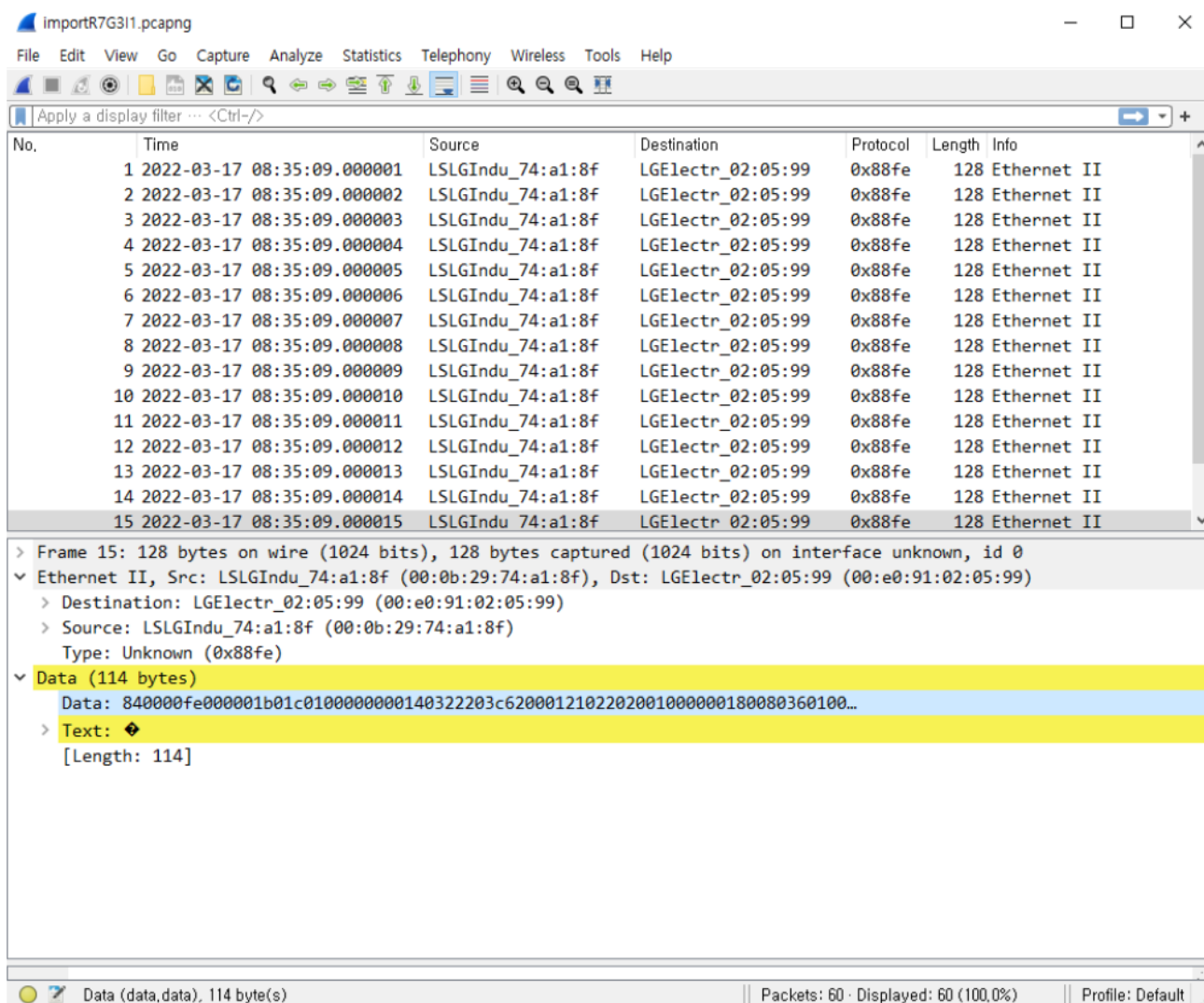

(4) Improved [Reset Individual Module] function

Improved the problem of remaining in I/O skip state when resetting individual modules while relay connection or remote connection of XGL-EFMTB is unstable. The improved [Reset Individual module] function is supported depending on the O/S version.

- Supported products: XGI-CPUUN O/S V1.8 or higher

(5) Improved Ethernet Remote 1 speed

When Ethernet remote 1 is connected, data can be transmitted in the maximum size.

[Step]

1. Click [Online] - [Connection Settings].
2. Select the method as [Ethernet Module], the step as [Remote 1], the read/write data size in PLC run mode as [Maximum], click [Connect].

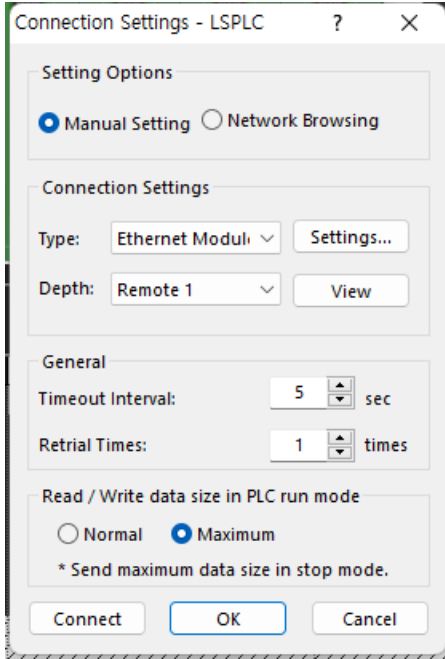

Notice

The models and O/S versions to which the remote connection speed improvement is applied are as follows.

- High performance XGI - V1.8 or higher
- High performance XGK - V1.9 or higher (planned)
- General XGK - V5.2 or higher (planned)
- General XGI - V4.4 or higher (planned)
- XGR – V3.0 or higher

(6) Improved CAM profile and CAM point

The number of cam profiles and cam points has been expanded.

Item	Before	After
XMC-E32A XMC-E32C LSMMT	CAM profile: 32 CAM point: 32,768	CAM profile: 100 CAM point: 65,536
XMC-E16A	CAM profile: 16 CAM point: 16,385	CAM profile: 50 CAM point: 32,768
XMC-E08A	CAM profile: 8 CAM point: 8,192	CAM profile: 25 CAM point: 16,384

(7) Word type variable/device binary number monitoring function

During monitoring, the monitor value of the variable is displayed in binary.

[Step]

1. Register an arbitrary variable in the monitor window.

Monitor 1							
	PLC	Program	Variable/Device	Value	Type	Device/Variable	Comment
1	LSPLC	<GLOBAL>	%MW0	16#1234	WORD		
2							

2. Click Context Menu - View as Binary.

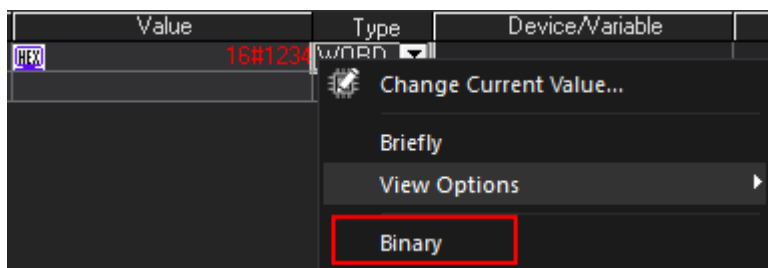

Monitor 1							
	PLC	Program	Variable/Device	Value	Type	Device/Variable	Comment
1	LSPLC	<GLOBAL>	%MW0	2#0001 0010 0011 0100	WORD		
2							

3. When changing the current value, it can be entered using binary numbers.

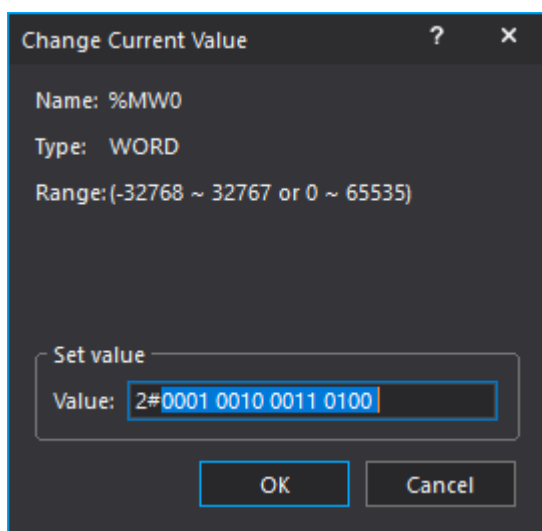

(8) Improved GROUP command device search

Added functions to find used device, device and memory reference for GROUP command in XGI model. However, it is possible only when parameters for index and size are used as constants.

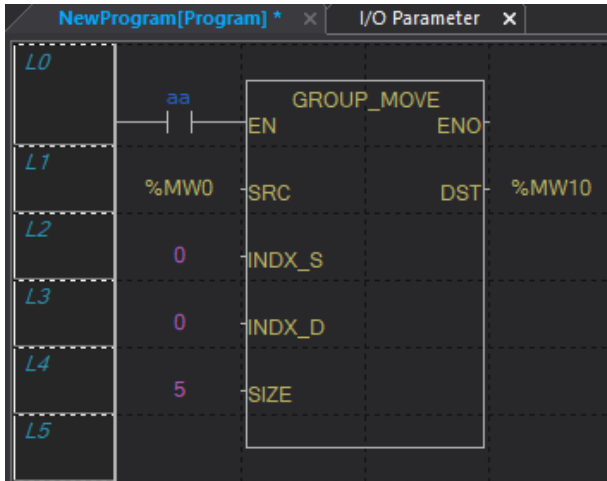

[Used Device]

Device	WORD																
	15	14	13	12	11	10	9	8	7	6	5	4	3	2	1	0	
%MW0 [%MX0]	1																
%MW1 [%MX16]	1																
%MW2 [%MX32]	1																
%MW3 [%MX48]	1																
%MW4 [%MX64]	1																
%MW10 [%MX160]		1															
%MW11 [%MX176]		1															
%MW12 [%MX192]		1															
%MW13 [%MX208]		1															
%MW14 [%MX224]		1															

[Find Device]

Find 1

← → ✕

In LSPLC, finding address "mw1"...

NewProgram[Program](Row 1, Col 0): - VAR - %MW1

1 address(es) found.

[Cross Reference]

Device Name	Variable	IN/OUT	PLC	Program	Position	Comment	Information
%MW0		INPUT	LSPLC	NewProgram[...]	Row 1, Col 0		GROUP_MOVE.SRC
%MW1		INPUT	LSPLC	NewProgram[...]	Row 1, Col 0		GROUP_MOVE.SRC
%MW10		OUTPUT	LSPLC	NewProgram[...]	Row 1, Col 3		GROUP_MOVE.DST
%MW11		OUTPUT	LSPLC	NewProgram[...]	Row 1, Col 3		GROUP_MOVE.DST
%MW12		OUTPUT	LSPLC	NewProgram[...]	Row 1, Col 3		GROUP_MOVE.DST
%MW13		OUTPUT	LSPLC	NewProgram[...]	Row 1, Col 3		GROUP_MOVE.DST
%MW14		OUTPUT	LSPLC	NewProgram[...]	Row 1, Col 3		GROUP_MOVE.DST
%MW2		INPUT	LSPLC	NewProgram[...]	Row 1, Col 0		GROUP_MOVE.SRC
%MW3		INPUT	LSPLC	NewProgram[...]	Row 1, Col 0		GROUP_MOVE.SRC
%MW4		INPUT	LSPLC	NewProgram[...]	Row 1, Col 0		GROUP_MOVE.SRC

(9) Improved [Import from File] of User Function/Function Block

When importing a user function/function block from a file, it has been improved to overwrite the program and local variables if a function/function block with the same name already exists in the project. If there is a change in the user function/function block, it can be updated more easily.

(10) Added user data auto-complete function

A function for auto-completion when entering a member of a user data type in the variable selection dialog box has been added. After the variable name of the user data type being used, you can select it from the list by entering the '.' character.

(11) Device search function for [PDO Variable] information window of EtherCAT Master

Device search, used device, and cross reference functions have been added for the device set in the PDO variable information window of the EtherCAT Master.

(12) String type in Node ID Type of OPC UA

String type has been added to Node ID Type in OPC UA function of XGL-EFMTB communication module.

(13) Added [Zoom-in] and [Zoom-out] function in ST program window

Added [Zoom-in]/[Zoom-out] (50~200%) function in ST/IL(IEC)/NC program window.

(14) Added function of batch adjustment of row height of variable monitor window

A function has been added for batch adjustment by changing the row height after selecting all rows in the variable monitor window.

(15) Added option [Always show direct variable comment window]

When inputting a variable in the editor, an option has been added to create the direct variable comment window regardless of whether there is a comment in the target variable. This option allows the Enter key action to display a dialog for the variable/description.

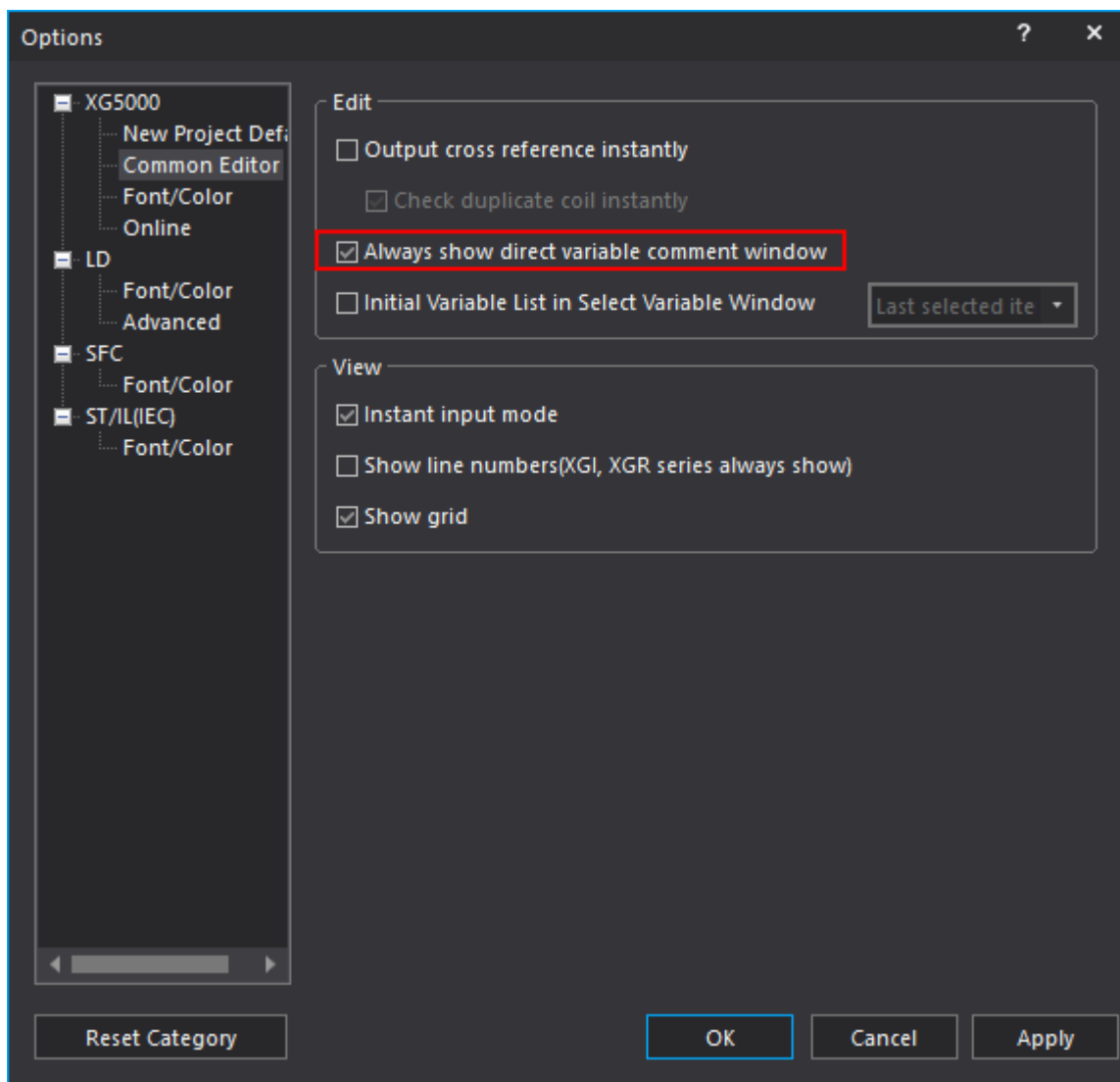

(16) Improved find target selection

Added a selection button to quickly select what to find and a function to select only programs or variables/comments in the multiple windows.

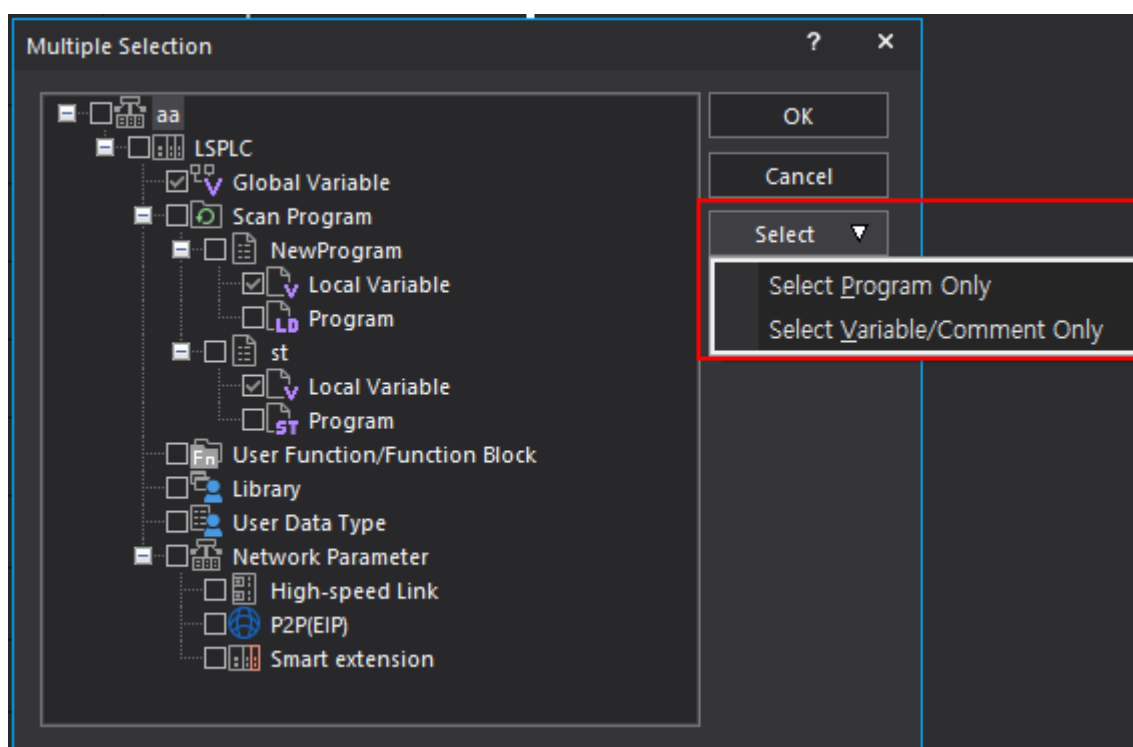
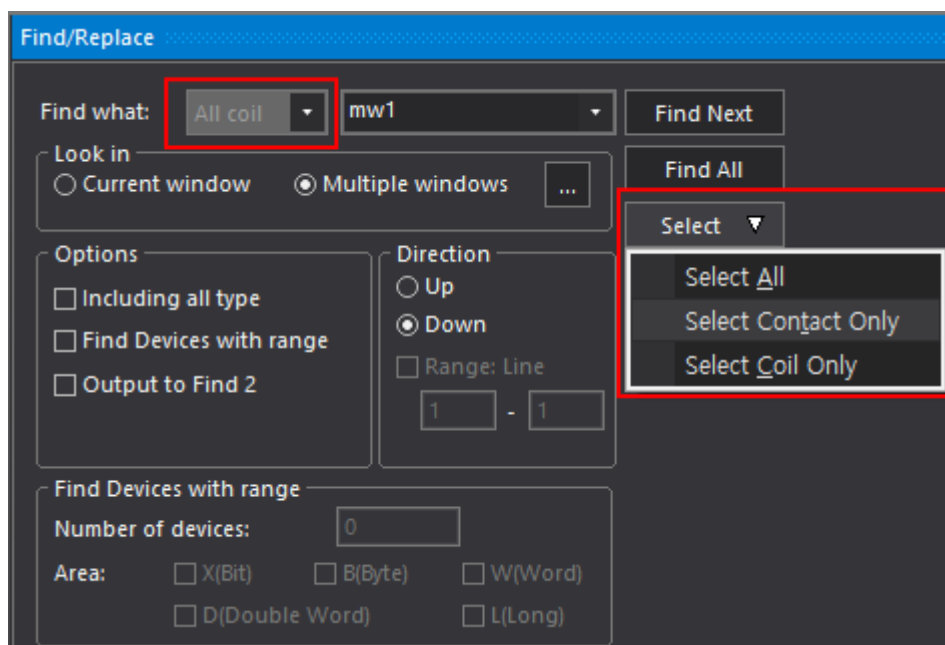

(17) Improved maximum number of local Ethernet dedicated connections (XMC)

The number of dedicated connections for local Ethernet of XMC type has been expanded to 8. To use the extended number, use the latest version of XMC O/S. When writing parameters, download may be restricted depending on the OS version.



(18) Added communication module variable

In XGL-EFMxB V8.60 and XGL-Cx2B V6.0 or later, variables that are turned ON when there is a user-defined communication receive frame and OFF when the receive frame is read have been added. In the case of the slot where the Cnet module is installed, the variable name and description have been modified.

(19) Added module reservation function(XGB)

A function has been added that allows you to reserve by assigning only the module's score without designating a specific module. By using the reservation function, the same program can be operated regardless of I/O type. 64 points are fixedly assigned to the slot for which the module reservation is set.

Slot	Module	Comment	Input Filter	Emergency Ou	Input info.	Output Inform
0(main)	XBC-DN/DP60S (DC 24		3 Standard[ms]	Default	P00000 ~ P0	P00040 ~ P0
1	XBE-RY08A/B (Relay Ou		-	Default	-	P00080 ~ P0
2	XB-IN64				P00120 ~ P0	-
3	XB-IN64				P00160 ~ P0	-
4	XBE-RY08A/B (Relay Ou		-	Default	-	P00200 ~ P0
5	XBE-RY08A/B (Relay Ou		-	Default	-	P00240 ~ P0
6	XBE-RY08A/B (Relay Ou		-	Default	-	P00280 ~ P0
7						
8						
9						
10						

[Step: Module reservation setting]

1. Set in the I/O parameter window.
2. Select the "XB-IN64" module in the slot that requires module reservation.
3. Execute write to apply to product.

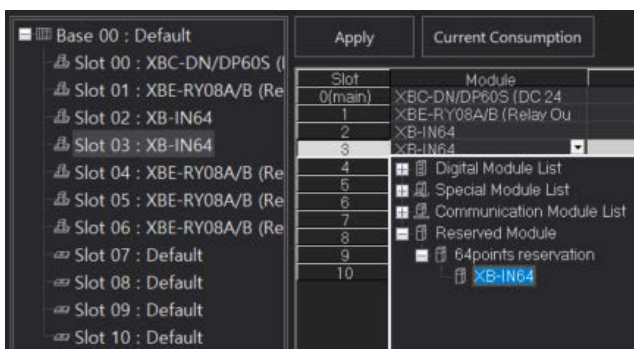

[Step: Cancel module reservation]

1. Set in the I/O parameter window.
2. Select the module to be actually mounted instead of the "XB-IN64" slot.
3. Execute write to apply to product.
4. Turn off the CPU power.
5. Mount the actual module to the product and turn on the power.

The module reservation function can be used from the CPU O/S version or higher below.

CPU	O/S 버전	CPU	O/S 버전
XGB-XBCS	V2.50	XGB-XECS	V2.40
XGB-XBCH	V3.30	XGB-XECH	V2.50
XGB-XBCU	V2.20	XBG-XECU	V2.20
XGB-XBCXS	V1.20	XGB-XEMH2	V2.30
XGB-XBMH	V1.50	XGB-XEMHP	V2.30
XGB-XBMH2	V2.30		
XGB-XBMHP	V2.30		
XGB-XBMS	V3.90		

(20) Add Axis/Axis group parameter (XMC)

For details, refer to the XMC user manual.

[Axis group parameter]

- Interpolation operation blending angle limit function - 'Interpolation operation blending angle limit', 'Interpolation operation blending allowable angle'
- Coordinate system operation look-ahead function – 'Coordinate system look-ahead setting'
- Coordinate system operation output filter function - 'Coordinate system output filter time constant'

[Axis parameters]

- Coordinate system operation maximum acceleration limit function - 'Maximum allowable acceleration in coordinate system operation', 'Maximum allowable deceleration in coordinate system operation'

(21) Improved EtherCAT automatic connection speed

By providing the option to read SDO parameters when auto-connecting EtherCAT slaves applied to XMC and XGI-CPUZ product groups, speed is improved when only essential operations for EtherCAT auto-connection are performed except for reading SDO parameters.

(22) Added EtherCAT parameter Touch probe position 1/2 negative value

Added setting function required to extend touch probe function of XMC and XGI-CPUZ family.

(23) Improved Cross Reference column selection storage

Improved to save column selection and width in Cross Reference function.

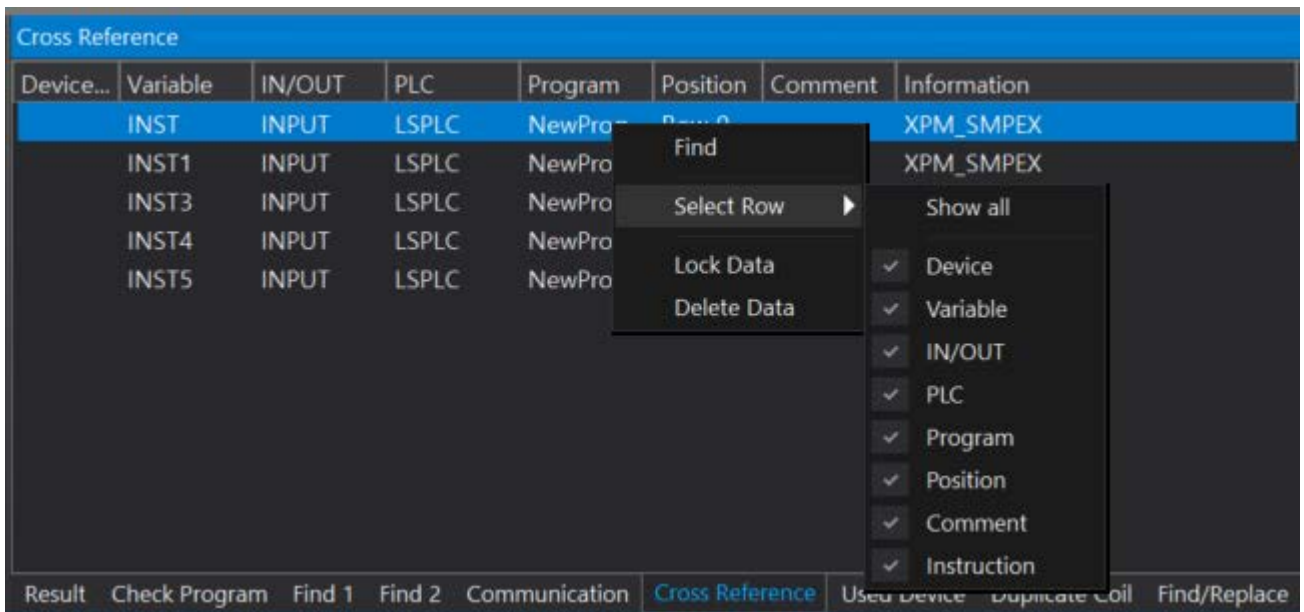

(24) Improved Paste options for direct variable comments

It has been improved so that the [Show confirmation message] option is applied even for direct variables with comments when pasting.

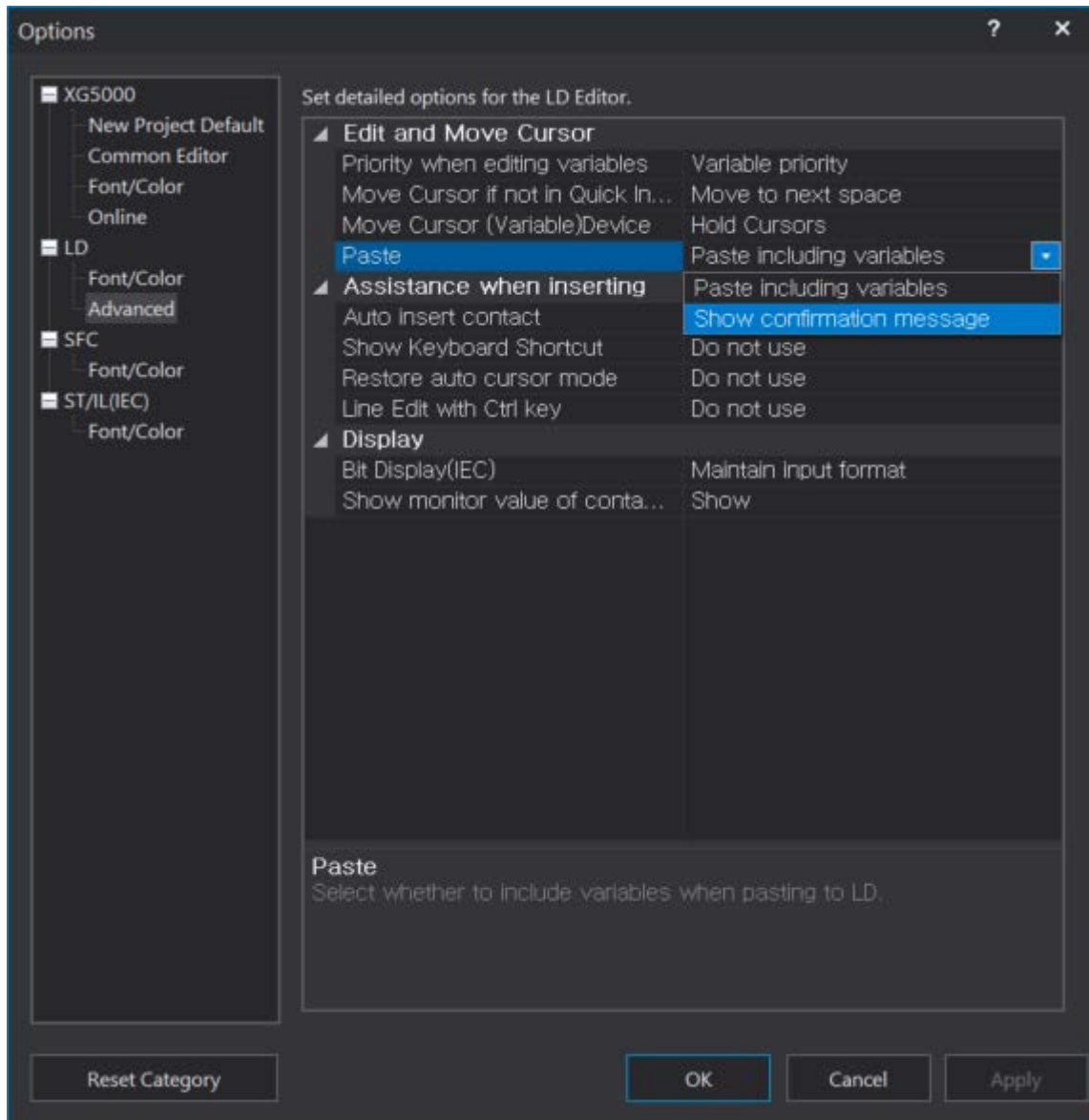

(25) Added motion data trace formula graph view

In the Trace Value View dialog box, the value for the formula graph has also been improved.

Show Trace Value ? X

Trace information
 Sampling Frequency: 1 X Control period [1.0 Total Samples: 6774 View settings

	%MX10	NewProgram::IN1	Math Graph
-1	OFF	29	58.0000000
0	OFF	0	14848.0000000
1	ON	0	0.0000000
2	OFF	0	0.0000000
3	OFF	31	62.0000000
4	OFF	0	16384.0000000
5	ON	0	0.0000000
6	OFF	0	0.0000000
7	OFF	34	68.0000000
8	OFF	0	17920.0000000
9	ON	0	0.0000000
10	OFF	0	0.0000000
11	OFF	37	74.0000000
12	OFF	0	19456.0000000
13	ON	0	0.0000000
14	OFF	0	0.0000000
15	OFF	40	80.0000000
16	OFF	0	20992.0000000
17	ON	0	0.0000000
18	OFF	0	0.0000000
19	OFF	43	86.0000000
20	OFF	0	22528.0000000
21	ON	0	0.0000000
22	OFF	0	0.0000000
23	OFF	46	92.0000000
24	OFF	0	24064.0000000
25	ON	0	0.0000000
26	OFF	0	0.0000000
27	OFF	49	98.0000000
28	OFF	0	25600.0000000

Close

(26) Added Instruction

The following instructions have been added. For details, refer to the instruction manual.

- High Performance XGK (XGK-CPUxN)
 - MSETDNETS
- High Performance XGI (XGI-CPUUN)
 - CP_MSG
 - SET_DNETS_PARAM
 - GROUP_SCH
 - GROUP_SUM
 - TICK_CUR, TICK_ET
- XGI (XGI-CPUx)
 - SET_CNET_PARAM
 - GET_CNET_PARAM
- XMC
 - GROUP_MOVE, GROUP_MOVE32
 - GROUP_FILL, GROUP_FILL32
 - GROUP_ROTATE
 - GROUP_SHIFT
 - ANY_MOVE, ANY_MOVE2

(27) Improved local Ethernet settings menu

The Ethernet menu used for local Ethernet settings in the high-performance CPU has been improved to the Ethernet Module menu and [Local Eth./Wi-Fi] menu. When using local Ethernet in the high-performance CPU, please use the [Local Eth./Wi-Fi] – [Local] menu.

Item	Type	Depth	Type before change
When using high-performance CPU Local Ethernet (XGK/XGI-N, XGB-U)	Local Eth./Wi-Fi	Local	Ethernet
When using remote 1 and 2 using communication module	Ethernet Module	Remote 1 Remote 2	Ethernet
When using XGI-CPUZ Wi-Fi	Local Eth./Wi-Fi	Local	-

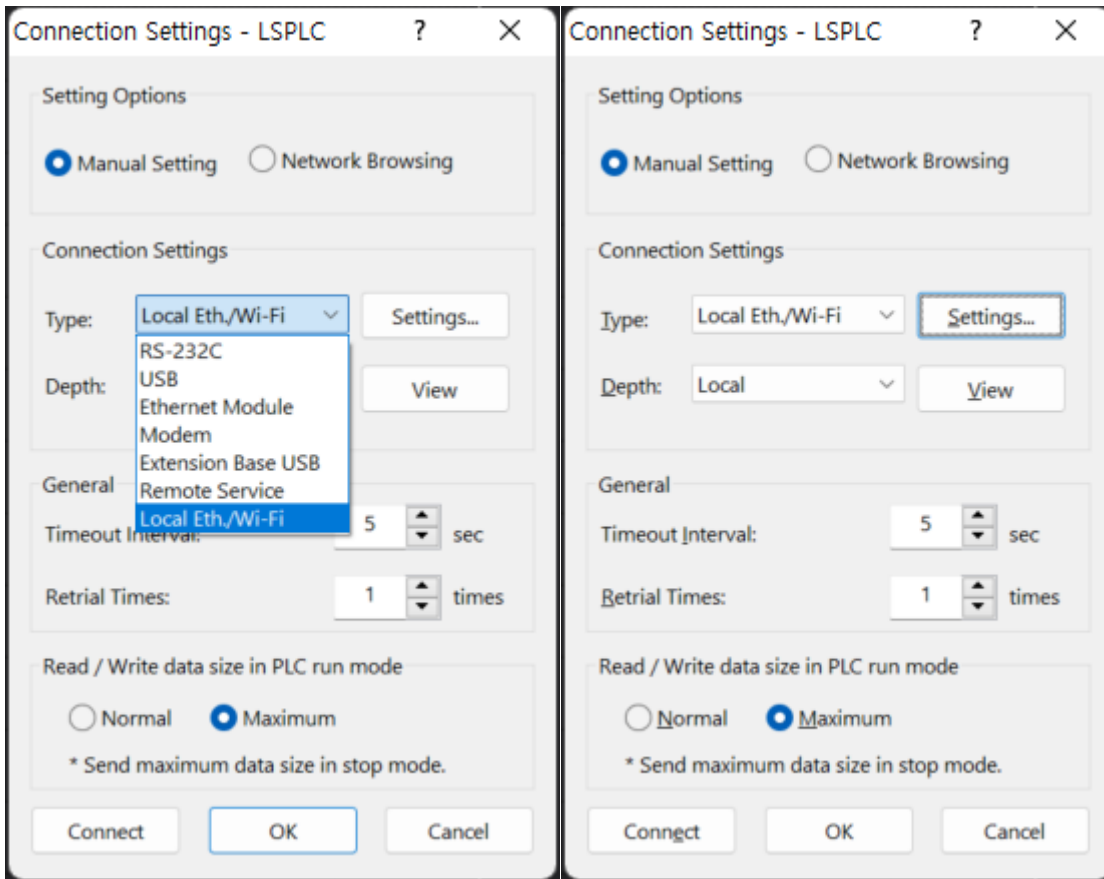

(28) Improved instruction help

The instruction help used in XG5000 has been improved from the existing Adobe Acrobat file (PDF) to the Help file (CHM).

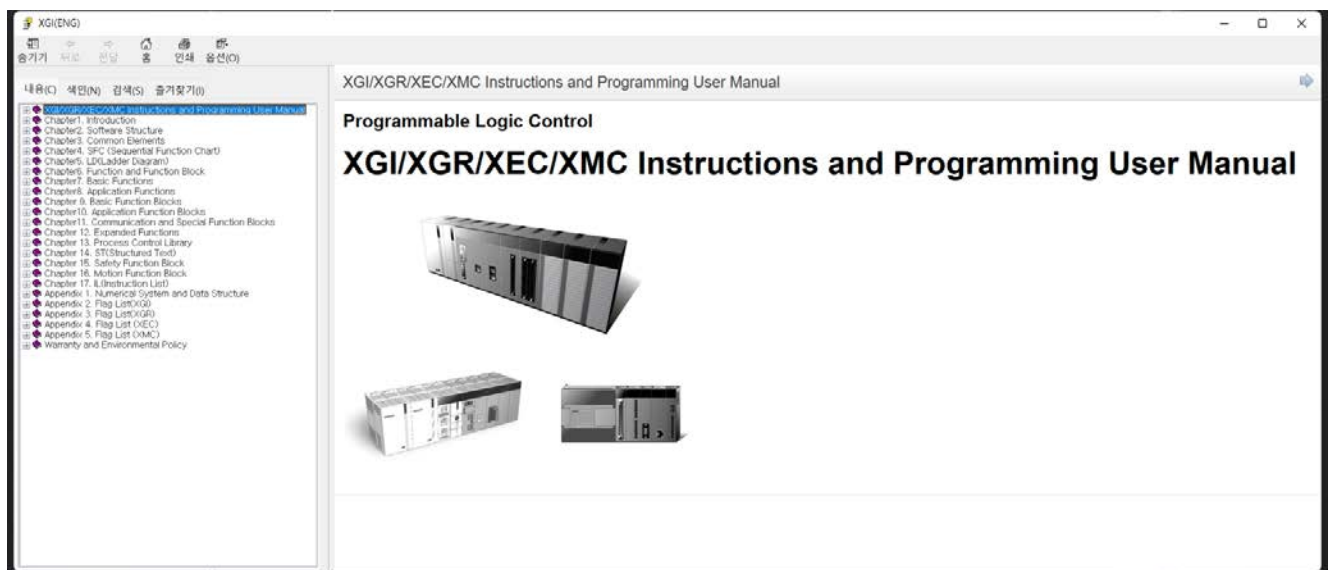
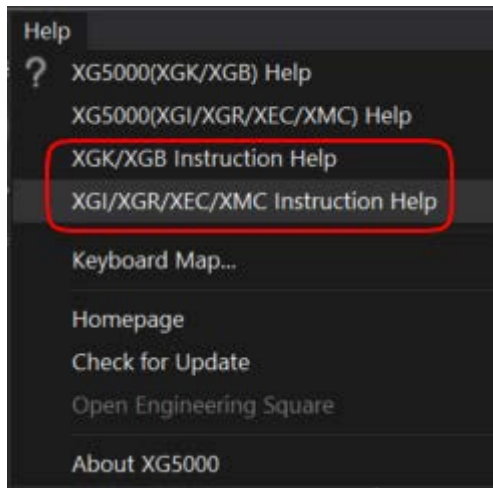

2. Error Correction

(1) Fixed the problem that error codes are displayed as numbers in the smart extension service tab

The smart extension service has been modified so that it can be displayed normally as a string for the error code of the slot.

(2) Fixed ladder copy & paste problem

The problem that copy & paste does not work in the ladder edit window has been fixed when the project window is in an auto-hide state.

(3) Fixed the problem that data swap in nConfigurator goes down in reverse

The problem that the opposite value to the set value goes down in the actual module when setting the data swap item in the Slave Properties window in nConfigurator for Profibus communication has been fixed.

(4) Fixed the problem of saving motion status window

The problem that the contents set through the monitor item setting of the motion status window is not saved when reopening after saving the project file has been fixed.

(5) Fixed the nConfigurator EDS file saving problem

Fixed the problem that if the vendor name provided in the EDS file is 32 or more characters, it is not saved in the NConfigurator that set the EDS.

(6) Fixed the ladder code conversion problem

Fixed an issue where when using a line edge (R_EDGE) contact in an OR circuit, it would not work due to a code conversion error.

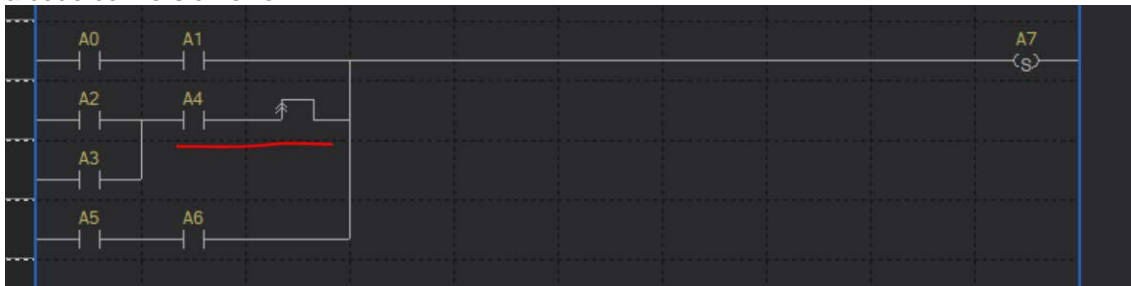

(7) Fixed the [Replace All] problem(XGK/XGB)

The problem that [Replace All] for bit devices does not work for devices with the same bit and word device types at [Replace All] has been fixed.

(8) Fixed the BYTE assignment problem in PDO variable information window

The problem that BYTE assignment for PDO variable information of EtherCAT parameter is not possible has been fixed.

(9) Added the user function and function block name restrictions

It has been modified so that ladder contact instructions (LOAD, LOADP, LOADN, ...) cannot be used when entering user function and function block names.

(10) Fixed the memory allocation problem for array types (BIT, BYTE, SINT, USINT) (XGK Auto-allocation)

The problem that setting cannot be made when memory allocation for array types (BIT, BYTE, SINT, USINT) is performed in the XGK Auto-allocation project has been fixed.

(11) Fixed the memory pasting problem of variables

The problem that memory allocation is deleted when pasting a variable allocated memory in the flag area to the global variable window has been fixed.

(12) Fixed the NC program infinite compilation problem

Fixed an issue that caused compile time delays when compiling intended infinite loop code.

(13) Fixed the message (An invalid argument was found) pop-up problem when setting EDS data

Fixed the problem that the block could not be set normally and a user message (An invalid argument was found) popped up when using some EDS data (XGL-EFMxB smart extension or XGL-EIPT P2P block).

(14) Fixed the parameter input problem when O2T size is 0

The problem that O2T Size is 0 in smart extension but remote tag column is activated and block setting cannot be completed has been fixed.

(15) Fixed the problem of not displaying system variables for P2P blocks

The problem that the data size is not reflected in the system variable for continuous type and WRITE type blocks in FENet P2P block has been fixed. An issue with different colors displayed in the program has also been fixed.

(16) Fixed the smart extension EIP detailed setting block T2O value range problem

The problem that 50ms cannot be set for T2O RPI/O2T RPI item in EIP detailed setting of XGL-EFMxB module smart extension has been fixed.

(17) Fixed BCC Settings dialog SWAP Settings control display problem

Fixed the issue where NONE was always displayed when re-opening after setting the value of the SWAP setting control in the BCC setting dialog box.

(18) Fixed the problem of comparison operation instruction in simulator mode (XBMHP, XBMH2)

The problem that incorrect operation result is output when R device is used as an argument of DWORD type comparison operation instruction (D=, D>, etc.) in simulator mode has been fixed.

(19) Fixed the problem when using select statement in ST program (XECE)

The problem that selection statements (IF~ELSE, CASE) do not work in ST program has been fixed.

(20) Fixed the problem that the project folder is not deleted

Fixed the problem that the existing project folder is not deleted in Windows Explorer after saving the project as a different name. This is a phenomenon that occurs because the files used in the existing project continue to remain.

(21) Fixed the program display problem when including FF instruction

The problem that the FF command is not displayed normally when reading from PLC has been fixed.

(22) Fixed the LD Program paste problem

The problem that the content copied from XG5000 is not pasted after copying from XG-PM has been fixed.

(23) Fixed the address translation problems for XMC remote I/O address space

The problem that the display form of the address is changed when reading from PLC when an address corresponding to the remote area is input in XMC has been fixed. Ex) %IX10.0.0 → Change to %IX10240

(24) Fixed the command problem

The problem that commands malfunction in some models has been fixed.

- CPU error occurs when using ARY_SCH2_USINT
- ANY_MOVE2_BOOL - If INDX_D is 8 or higher
- XPM_SSTEX step number is displayed
- Some commands do not work in user function blocks - XPM_GET, SEND_UDATA

(25) Fixed timeout problem when connecting to XGB Enet Remote 1

Fixed an issue where a timeout occurred when connecting to Remote 1 in XGB models.

(26) Fixed the problem that the station number set in XGL-EFMxB is changed to 0

The problem that XGL-EFMxB station number is initialized to 0 when an old version project is opened in XG5000 V4.7 (2022-07-19) version has been fixed.

(27) Fixed the problem that XG-PM does not execute

The problem that XG-PM does not execute when there is no recent file information has been fixed.

■ ReleaseNote - XG5000 V4.61

1. Error Correction

(1) XGI/XGR/XEC/XMC CPU malfunction when Label or SBRT(subroutine) is added through online editing

- When adding a [Label]/[SBRT] through online editing after [Open from PLC] in the PLC using the [Label], the CPU malfunctioned due to internal overlapping with the previously registered [Label] has been improved.

(2) Fix other errors

* XG5000 V4.61 is a version that has improved the above errors in the previous V4.60.6 version.

■ ReleaseNote - XG5000 V4.60.5 (Beta)

1. Improvements and additions

(1) Improved copy of comments when pasting variables directly(IEC)

When copying/pasting in the LD program, it has been improved to select whether or not to copy the variable comments directly.

(2) Added Function(XGI-CPUUN)

For details, refer to the XGI/XGR/XEC/XMC instruction book.

- GROUP_SCH
- GROUP_SUM

2. Error Correction

(1) Ladder copy and paste not working

The error that copy & paste does not work normally in the LD edit window has been improved when the project window is automatically hidden.

(2) Fix command problem

The problem that commands malfunction in some models has been fixed.

- Problem in communication parameter change when using B contact pulse.
- Problem when DATA type of ARY_SCH2 Function is USINT.

Notice

XG5000 V4.60.5 is a beta version with several functions and errors corrected in V4.60. Please refer to the Release Note and use it only when necessary. Otherwise, please use the official version of XG5000 V4.60. (Additional functions may not work depending on the product O/S version.)

■ ReleaseNote - XG5000 V4.60.4 (Beta)

1. Improvements and additions

(1) 'Auto variables retain value' maintenance function

A function that can save or restore retain values for Auto variables(variables that are not directly addressed by the user).

- Retain: A function to keep the data generated during operation in the warm restart mode even when the PLC restarts from the stop mode.

1) Functional description

This is the function to write the 'Auto variables retain value' stored inside the XG5000 project when writing the program. The [Auto variables retain value] saved in the XG5000 project is the value read during [open from PLC] and can also be read through [Online]-[Read].

[Select 'Auto variables retain value' when reading]

- When [Open from PLC], 'Auto variables retain value' is read together by default.
- The default value for 'Read' is unchecked.
(However, if it has already been selected once, it is maintained until the project is closed.)

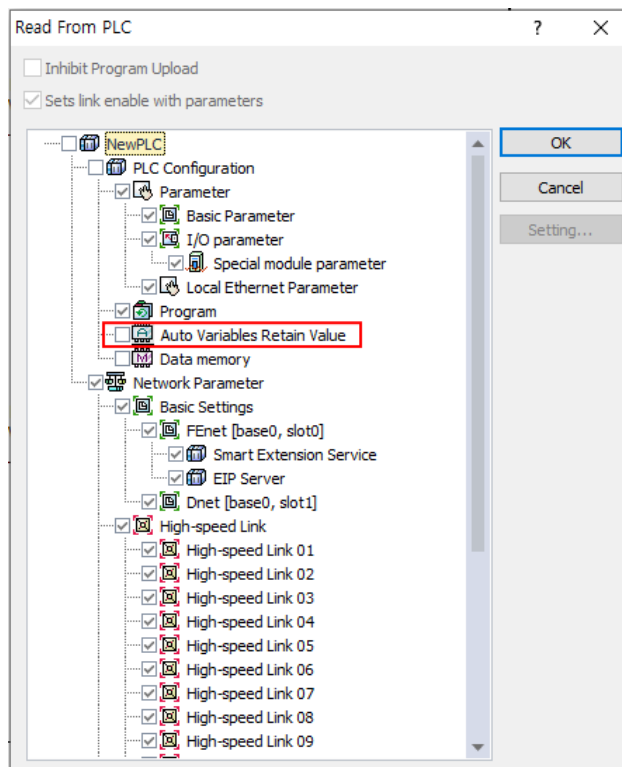

[Select 'Auto variables retain value' when writing]

- When writing, the default value of 'Auto variables retain value' is unchecked. (However, if it has already been selected once, it is maintained until the project is closed.)

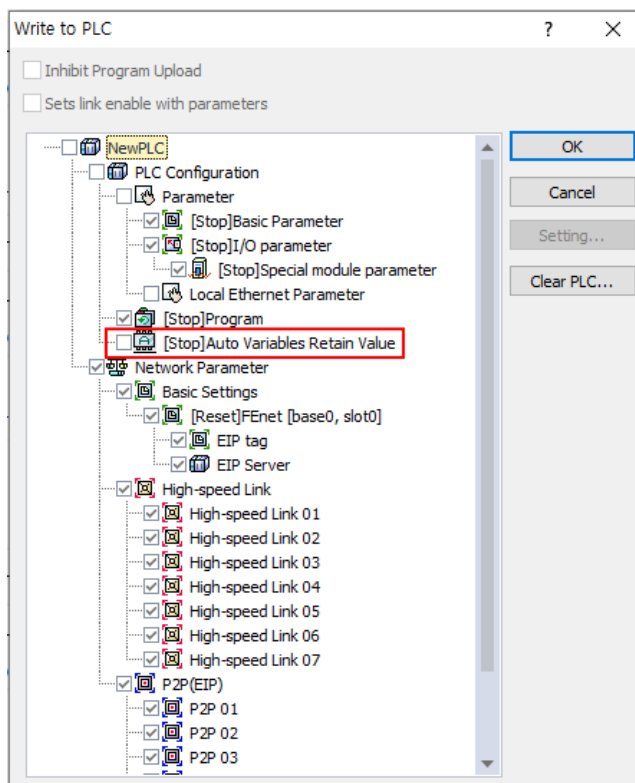
**2) Constraint description****[Read 'Auto Variables Retain Value']**

- When [Online] - [Read], it is possible to read 'Auto variables retain value' without selecting a program.
- If the program stored in XG5000 and the program in PLC are different, different values may be saved. Please be careful. (Please use only when you want to read the 'Auto variables retain value' repeatedly after reading the program.)

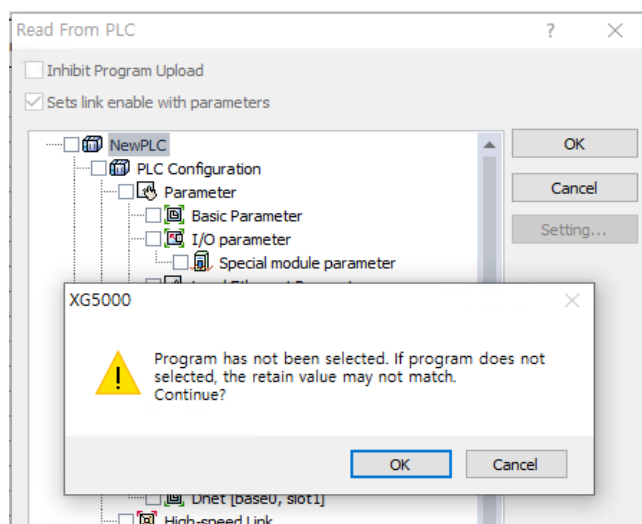

[Write 'Auto Variables Retain Value']

- If no program is selected, writing is not possible. Please be sure to select it with the program.

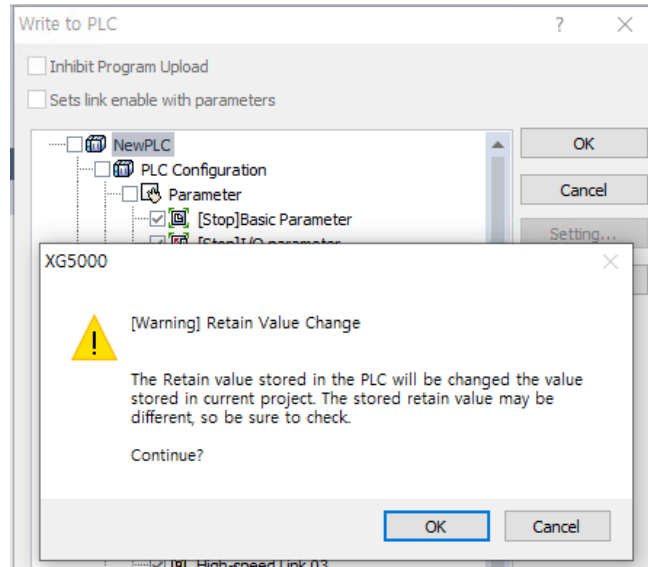

[Initialize 'Auto Variables Retain Value']

When the address or property of a variable is changed, it is initialized to 0 or applied to the initial value entered by the user.

- Auto variables with newly added retain
- When the data type of Auto variables is changed
- When the properties of an array are changed (size, type, dimension)
- User data type or variable added to user function block
- When the program name is changed

3) Notice

- If 'Auto variables retain value' is not selected when writing a program after the Auto variables address has been changed, the value of the Auto variables in the PLC may be changed to an arbitrary value (if the initial value is set, it is changed to the initial value) .
- Write the program by setting the 'Auto variable retain value' together.
- If there is a value that is changed during PLC RUN mode, it must be read in the STOP mode. Even if it is the STOP mode, the value changed through communication such as HMI is not maintained.
- If the Auto variables are changed by using the 'Reallocate All Auto-allocation variables' function or by using the 'Use edit during run' option in the user function/function block, use this 'Auto variables retain value' maintenance function when writing the program.

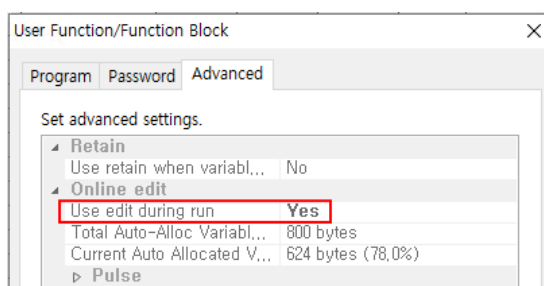
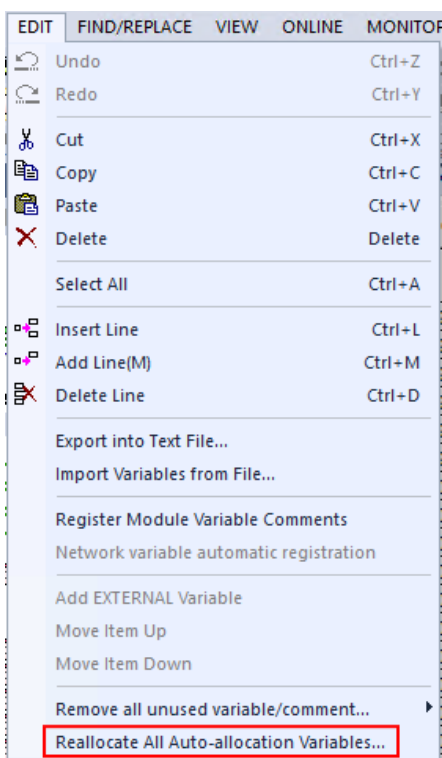

- This function is possible only when the restart mode is set to 'Warm restart' in the basic parameter. In 'Cold restart' mode, it operates with 0 or the initial value specified by the user.

Parameter \ Mode	Cold	Warm
Default	Initializing as '0'	Initializing as '0'
Retain	Initializing as '0'	Maintaining the previous value
Initial value	Initializing as a user-defined value	Initializing as a user-defined value
Retain & initialization	Initializing as a user-defined value	Maintaining the previous value

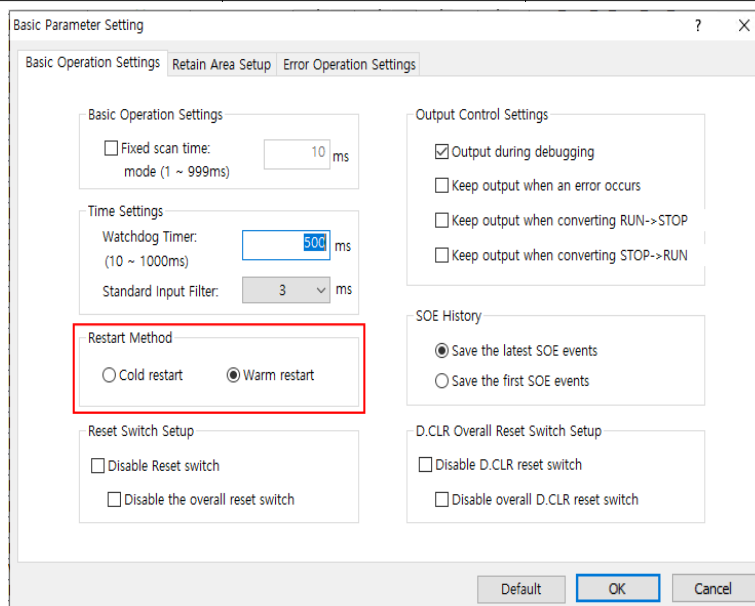

- If the 'Show selection dialog when executing Open from PLC' option is set, 'Auto variable retain value' can be set even when opening from PLC.

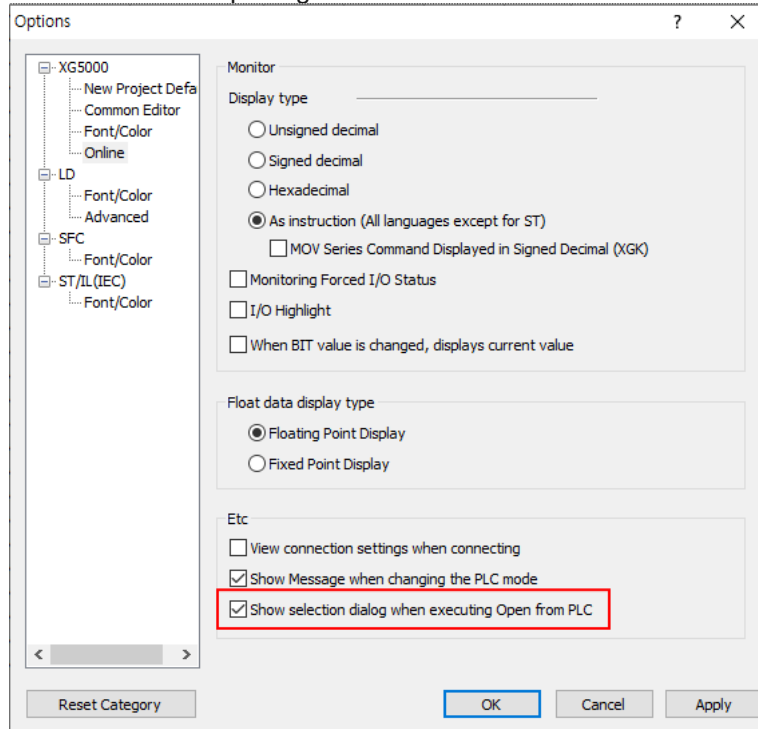

- The 'Auto variable retain value' maintenance function can be applied only when 'Write' in STOP mode. It is not applied to 'Online editing' or 'Online force editing'.
- The XEC type does not support the 'Auto variables retain value' maintenance function.

4) User guide

The following is the procedure for modifying the program of the user function block in which 'Auto variables retain value' maintenance function is set.

- ① Switch PLC to stop mode.
- ② When 'Open from PLC' or 'Read' from PLC, select 'Program' and 'Auto variables retain value'.
- ③ Modify the program of the user function/function block or change the 'Use edit during run' option.
- ④ When writing a program, select the 'Program' and 'Auto variables retain value'.

2. Error Correction

- (1) When registering Ethernet/IP tags, the error message of the size of the tag has been corrected.

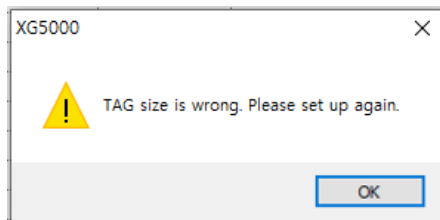

Notice

XG5000 V4.60.4 is a beta version with several functions and errors corrected in V4.60. Please refer to the Release Note and use it only when necessary. Otherwise, please use the official version of XG5000 V4.60. (Additional functions may not work depending on the product O/S version.)

■ ReleaseNote - XG5000 V4.60.3 (Beta)

1. Improvements and additions

- (1) In the [Compare with PLC] menu, when the EB item of smart extension is different, the phenomenon that project comparison is not performed has been improved.

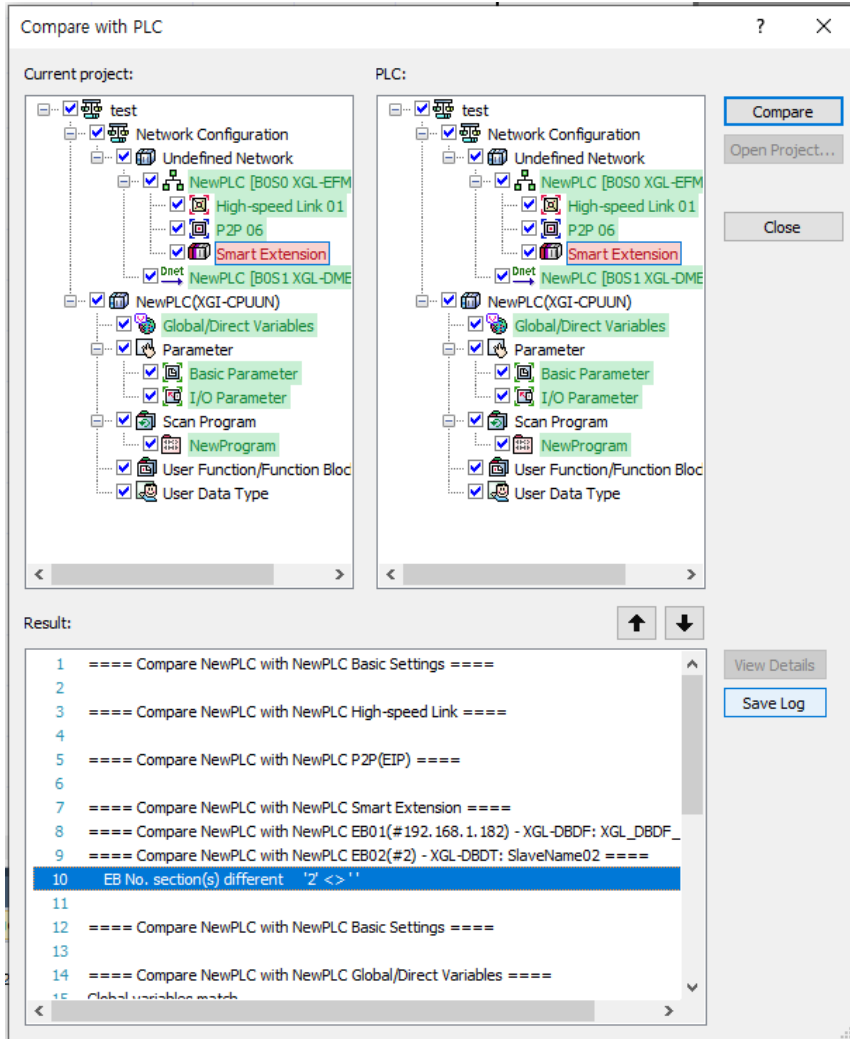

- (2) When entering a device in the [Master]-[PDO variable] tab of the EtherCAT parameter, the message “Device is assigned duplicated.” has been improved.
 “The device is included in the set area (Duplicate device area). Please set it to a different area.”

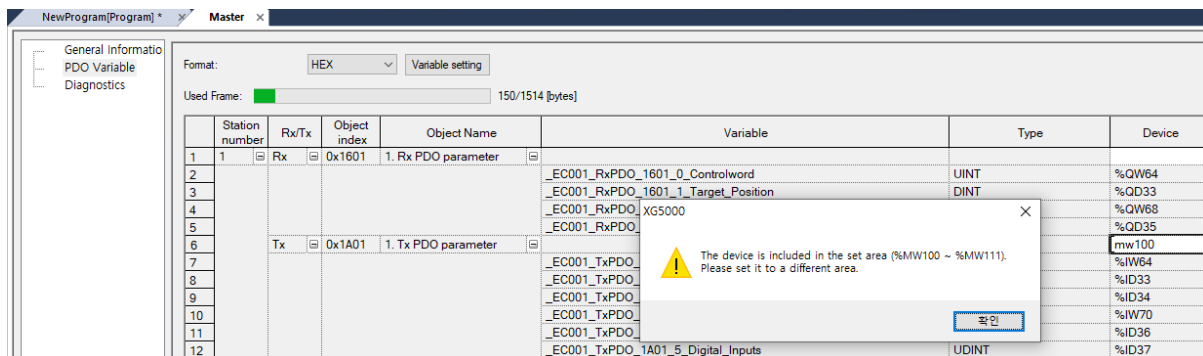

- (3) In the diagnostic variable list of smart extension, only WORD type devices were available, but BIT type devices can be set in BYTE units as well.

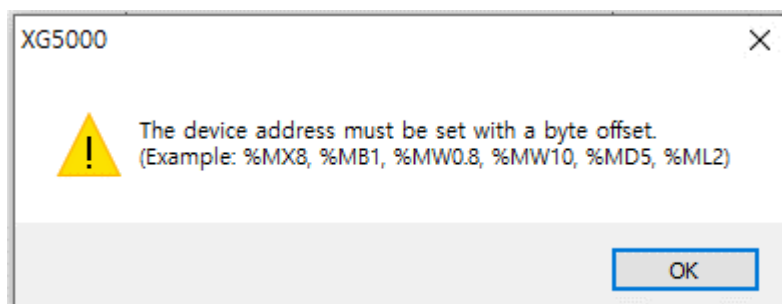

- (4) The [Save Module History] function has been added to XG-PM. By using this function, information related to module and XG-PM can be saved at once.

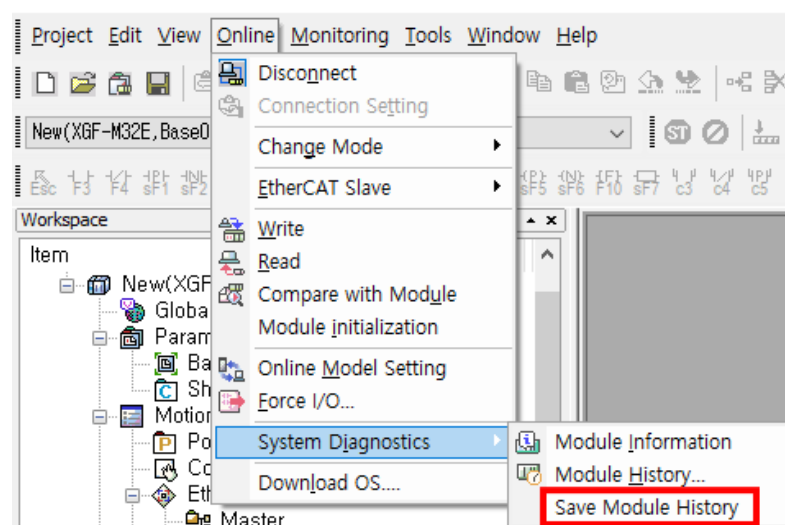

- (5) Increase the number of [User Data Type]
 The number of items that can be used within a [User Data Type] has been changed from 1,023 to 4,095. If more than 1,023 types in one [User Data Type] are used, it may not be opened in the old version of XG5000. (Display message using latest version)

2. Error Correction

- (1) When opening from PLC in the XMC project, the problem that the PLC option [Use External Variable] is changed and not uploaded has been fixed.
- (2) The problem that the memory of input/output/diagnostic variables registered in global variables in smart extension is edited during Multi-User Online Editing has been fixed.
- (3) Use the global variable automatically assigned as retain in the user function block or PB program. After writing multi online editing, open from PLC and start editing while running again. At this time, the problem that the program of user function block and PB is displayed in edit state has been fixed.
- (4) The problem that the [Online]-[Read] menu is activated during editing during run has been fixed.
- (5) After executing the [Edit]-[Import Variables from File] menu in the global variable list, it has been improved so that online editing cannot be started when connecting to the PLC.
- (6) The problem that the [Edit]-[Insert/Add/Delete Line] menu is activated while editing a user function block during run has been fixed.
- (7) If there is a structure in the input parameter of the user function block, the problem that a compilation error occurs when the input structure member of the user function block is used in the program has been fixed.
- (8) The problem of abnormal termination when deleting the window created with the [Window]-[New Window] menu with the master and slave windows of EtherCAT parameters open in the XMC project has been fixed.
- (9) The problem in which the initial value of the variable added while editing the user function block during execution is set has been fixed.
- (10) The problem that the variables of VAR_INPUT, VAR_OUTPUT, and VAR_INOUT are changed by string replacement while editing the user function block during execution has been fixed.
- (11) When XG5000 V4.60 is installed while the old version is installed, the problem that the existing XGService is not updated to XG5000 V4.60 has been fixed.

- (12) The problem of abnormal termination when operating with the older version of XGService (V4.50 or lower) has been fixed.
- (13) The problem of connecting to PLC in read-only mode has been corrected.
- (14) It has been modified to disable the SDO save function of the EtherCAT slave without the SDO save function in the XMC project.
- (15) Set the setting driver [LS INV 485 Client] in the P2P block window of the Cnet communication module. The problem that the list is not displayed when selecting an inverter variable after setting the P2P function to WRITE has been fixed.
- (16) When an array type tag is used in the P2P block window of the EtherNet/IP module, an error occurred in the comparison between the size of parameter content and the number of arrays has been fixed.
- (17) An error occurred in storing the device address of the array type remote tag when displaying the set block in the smart extension EIP detailed setting window has been fixed.
- (18) The problem of abnormal termination of XG5000 when executing forced I/O setting window in XMC has been fixed.
- (19) The problem that GSD Syntax error occurs when Slave_Family of GSD is 12 in Pnet nConfigurator has been fixed.
- (20) After the XGI-CPUUN OS version upgrade, the problem that [Open from PLC] cannot be opened in the latest version of XG5000 has been fixed.

Notice

XG5000 V4.60.3 is a beta version with several functions and errors corrected in V4.60.
Please refer to the Release Note and use it only when necessary.
Otherwise, please use the official version of XG5000 V4.60.
(Additional functions may not work depending on the product O/S version.)

■ ReleaseNote - XG5000 V4.60.1 (Beta)

1. Error Correction

(1) Fixed subroutine information creation failure error (E2033)

(XGK automatic allocation)

If the same label is used in the XGK auto-allocation program, the problem that subroutine information creation failure error is displayed when [Online Editing] after [Open from PLC] has been fixed. In order to use it normally, please write the program on Stop mode.

(2) Fixed MOVE function problem in ST program(XGI, XGR, XMC)

The problem that the value of the REAL type variable cannot be copied when using the MOVE function in the ST program has been fixed.

(3) Fixed the problem that user function block members are initialized

When an array type is used for input/output of user function blocks, some members are initialized to 0 and abnormal termination problems have been fixed.

(4) Fixed the problem of coils connected to normally closed contacts when array index exceeded error occurred

Fixed an error where the corresponding output did not work when the bit array was used as a normally closed contact when an index exceeded error occurred.

(5) "Cnet status error" message is displayed(XMC-E32A)

Fixed an error where "System error, Cnet status error" was displayed in the module error history list.

(6) Fixed auto scan problem during smart extension

If RAPIEnet is enabled in FEnet communication module and smart extension service is added, the problem that RAPIEnet protocol is set as EtherNet/IP protocol has been fixed if auto scan is performed in smart extension.

(7) Fixed the EtherCAT setting problem(XMC)

Problems related to the configuration of the PDO address calculation information of EtherCAT parameters and the problem of not being able to recover when the slave port connection information is abnormal has been fixed.

(8) Other abnormal termination error correction

The abnormal termination problems have been fixed.

Notice

XG5000 V4.60.1 is a beta version with several functions and errors corrected in V4.60.

Please refer to the Release Note and use it only when necessary.

Otherwise, please use the official version of XG5000 V4.60.

(Additional functions may not work depending on the product O/S version.)

■ ReleaseNote - XG5000 V4.6

1. Improvements and additions

(1) Added the "Use online edit" option of the User Function/Function Block(XGI, XEC, XGR)

The "Use online edit" option has been added to the User Function/Function Block [Properties...] – [Advanced].

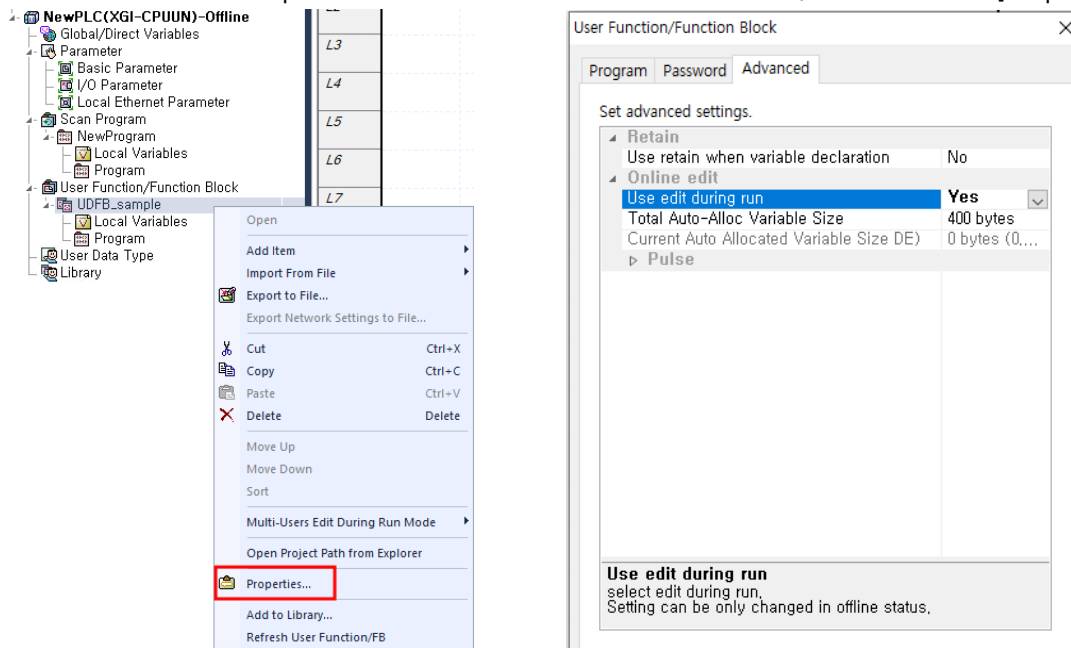

(2) Added large comment function(XGK-N)

Added ability to use large comment for XGK-N (XGK-CPUSN/HN/UN V1.62 or higher).

Comments up to 8 MB can be used.

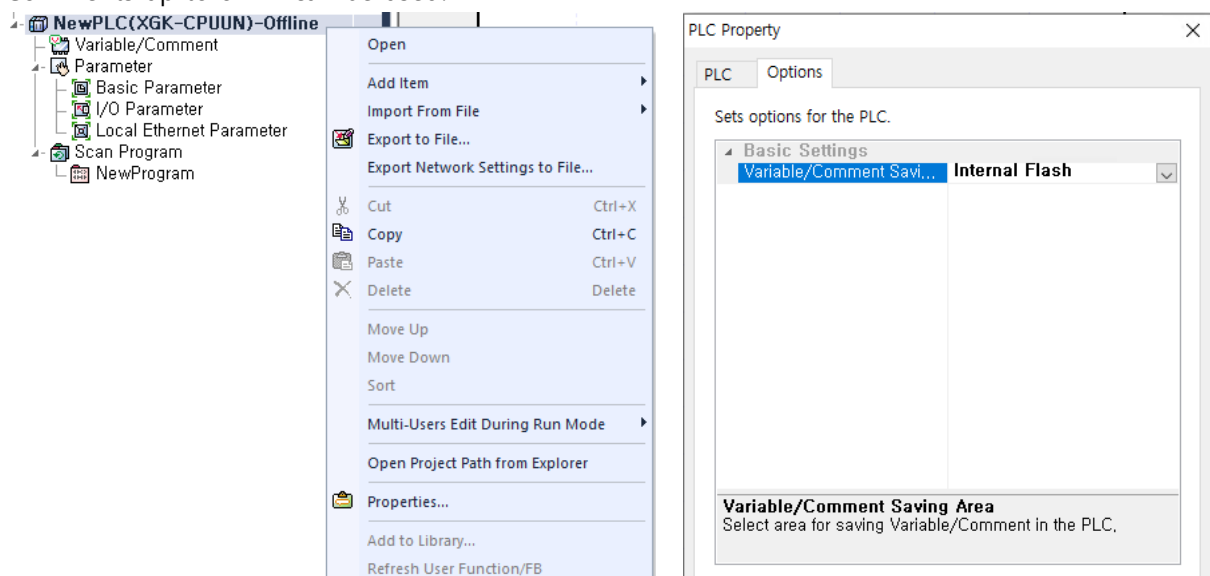

(3) Added the program protection mode

Program protection mode is a function that can be downloaded without displaying the program contents for the project for which the password is set. In order to use the program protection mode, the project password and the protect program option must be set.

[Steps]

1. In the project tree, select the [Properties...].
2. In [Project] – [Password] tap, select "Permit open protection mode without password".

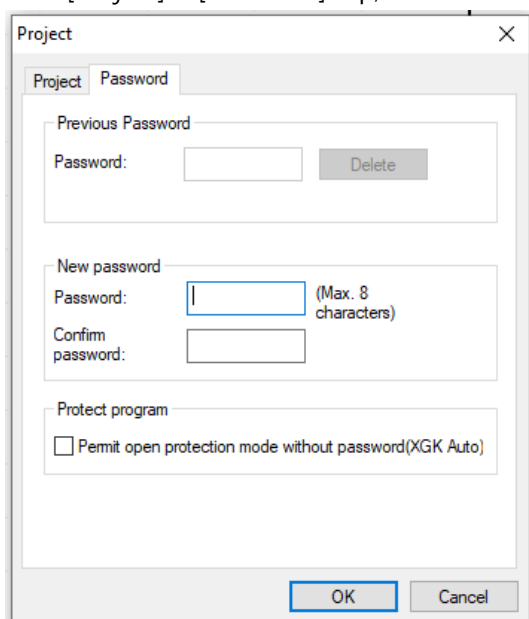

[How to use]

If you open a project with protection mode, you can select the edit mode by using the Yes/No/Cancel buttons in the message box.

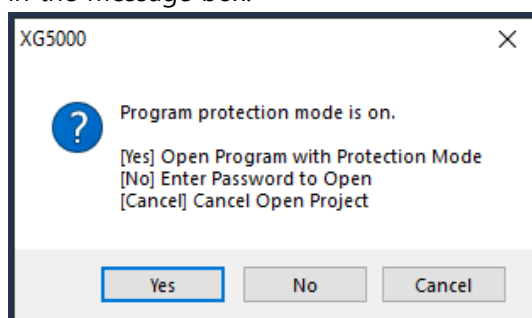

1. When [OK] is clicked – Protection mode

Opens the project in protection mode without entering a password. The contents of the project are not displayed and only actions related to download can be executed. The selected PLC item can be downloaded, but the contents cannot be checked. To open in edit mode, close the project and then reopen it.

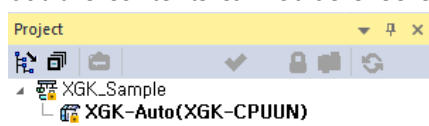

2. When [No] is clicked – Project edit mode

If you know the password, you can open the project in edit mode.

When it is opened in edit mode, all functions are available, including changing the protect program option.

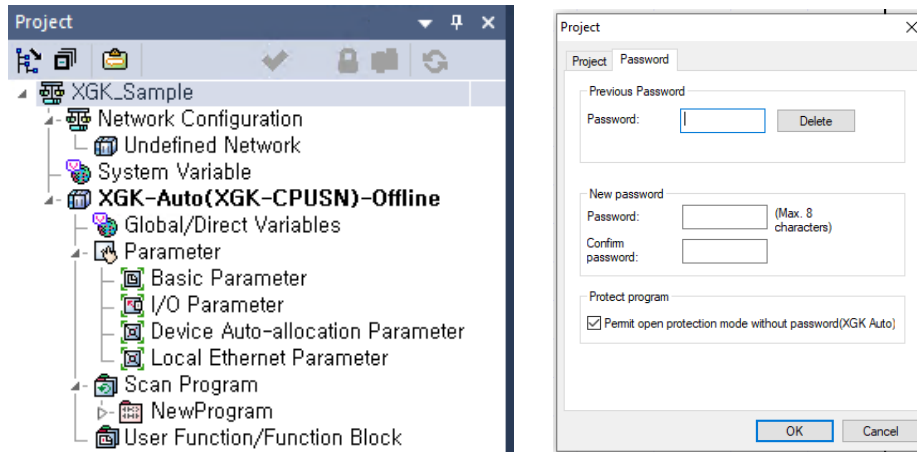

※ The protection mode is also applied when opening from PLC.

[Notice]

- Protection mode only supports V4.60 or higher, so it cannot be opened from PLC in lower version.
- If you open a project with protected mode under V4.60, you need to know the password to open it.
- If there is a PLC that does not support the protected mode in the project, a warning message is displayed when saving.
- Program writing is not allowed if it does not support protection mode.
- [Online] – [Read] operation is not supported.
- When [Compare projects], it always operates in password mode.

(4) Added password setting function for each program(XGK Auto-allocation)

A password setting function for each program has been added to the XGK Auto-allocation project. Projects with passwords cannot be opened in versions below V4.6.

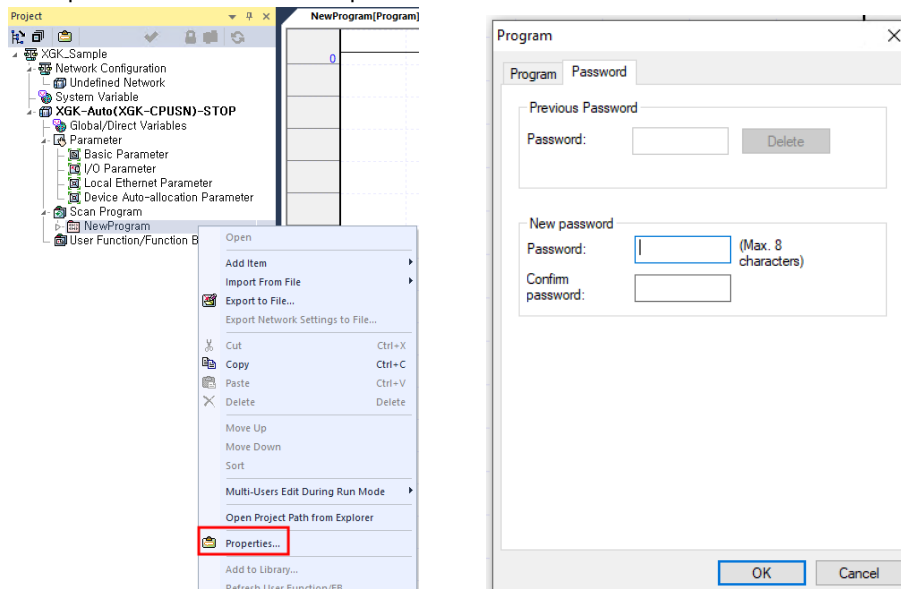

(5) Added Navigator function

The tag added to the rung comment of the LD program is displayed, and it is a function to move directly to the comment when clicked.

[Steps]

1. Select [EDIT] – [Insert Comment/Lable].
2. In the dialog box, enter a comment with tags and click the [OK] button.

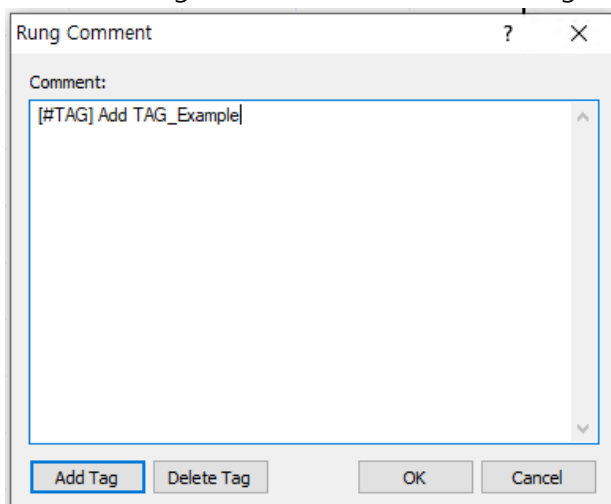

4. Go to the navigator window and click [Refresh all].

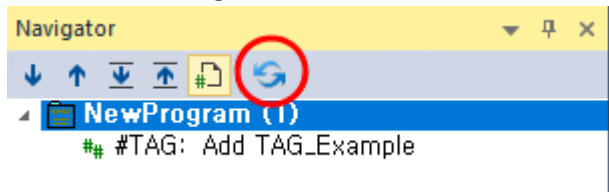



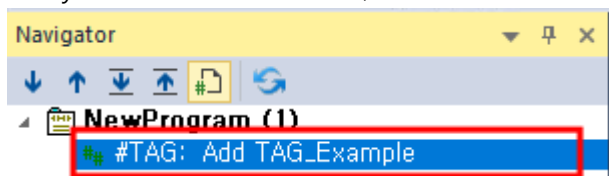



5. If you double-click an item, it moves to the corresponding location.



[Toolbar Description]



1. Navigate to next item() - Move to the next item among all items.
2. Navigate to previous item() - Move to the previous item among all items.
3. Navigate to next item in the group() - Moves to the next item in the group.
4. Navigate to previous item in the group() - Moves to the previous next item in the group.
5. Grouping() - Select how to group by program or tag name.
6. Refresh all() – Refresh all items.

[Notice]

1. Items displayed in the navigator do not refresh automatically.
2. Tag comments used in SFC's Action/Transition program are not displayed.
3. If it has been edited since it was refreshed, it cannot be moved to the exact location.
4. When the grouping attribute is changed, the entire item is automatically updated.
5. When all items are refreshed, they are changed to the collapsed state, and if the name is the same, the state is remembered.

(6) Improved the program activation function (XGI, XGR, XEC, XGK Auto-allocation)

It has been improved to activate the program by double-clicking the program in the project that includes local variable.

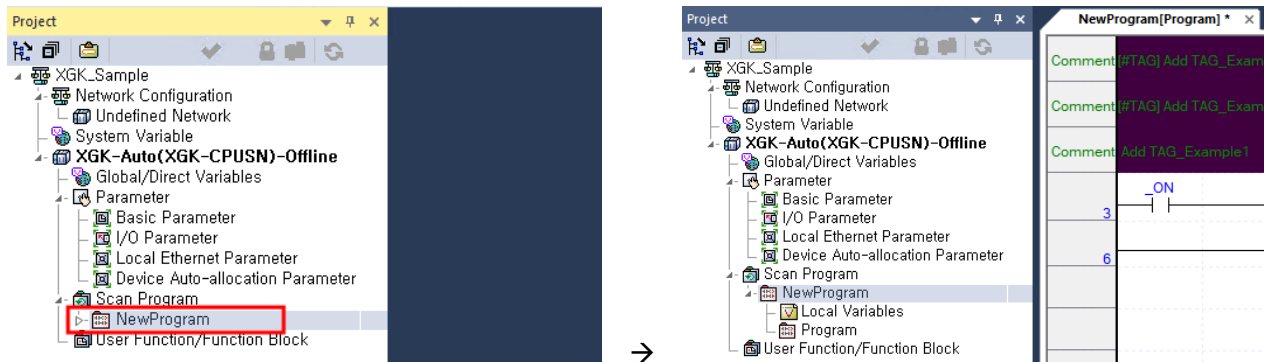

(7) Improved [Compare Projects] function

[Compare Projects]

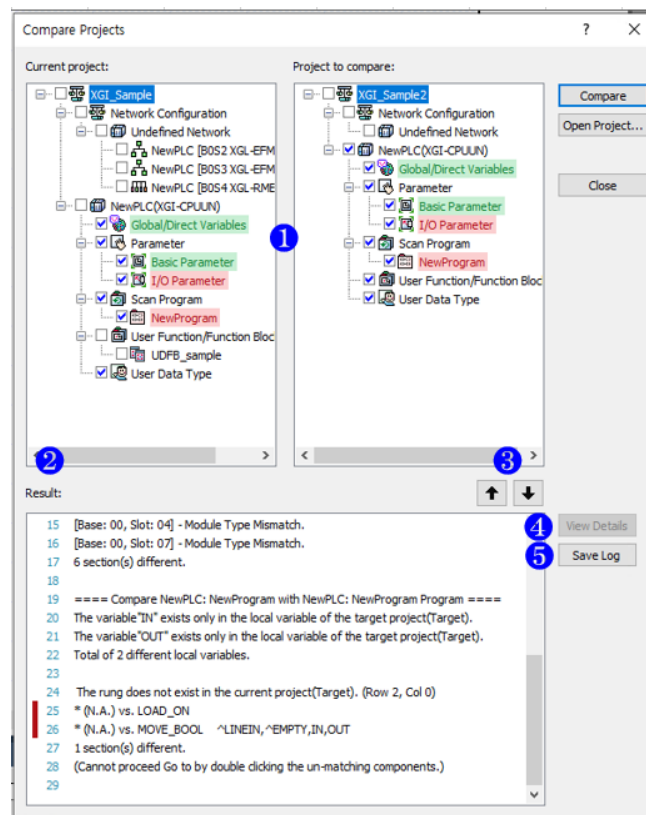

- (1) Visualize comparisons within the tree: After comparison, show **Match** / **Mismatch** according to the result.
- (2) Result: After comparison, the result is displayed in the [Result] list. Mismatches are displayed in front of the index for easy identification.
- (3) Up/Down: Search the contents of the list based on the item selected in the tree of (1).
- (4) View Details: When selecting an item in the tree in (1) after [Compare], if [View Details] is supported, the [View Details] button is activated. At this time, the item in the tree to be compared with the selected item is also selected.

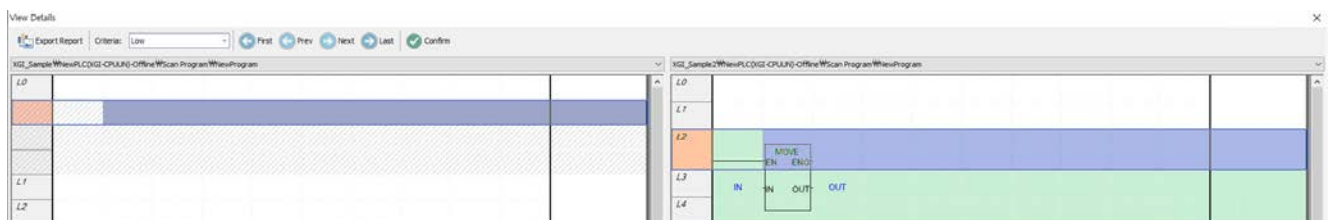

- (5) Save Log: Export the comparison result of (2) to a log file (*.log; text-based).

[View Details]

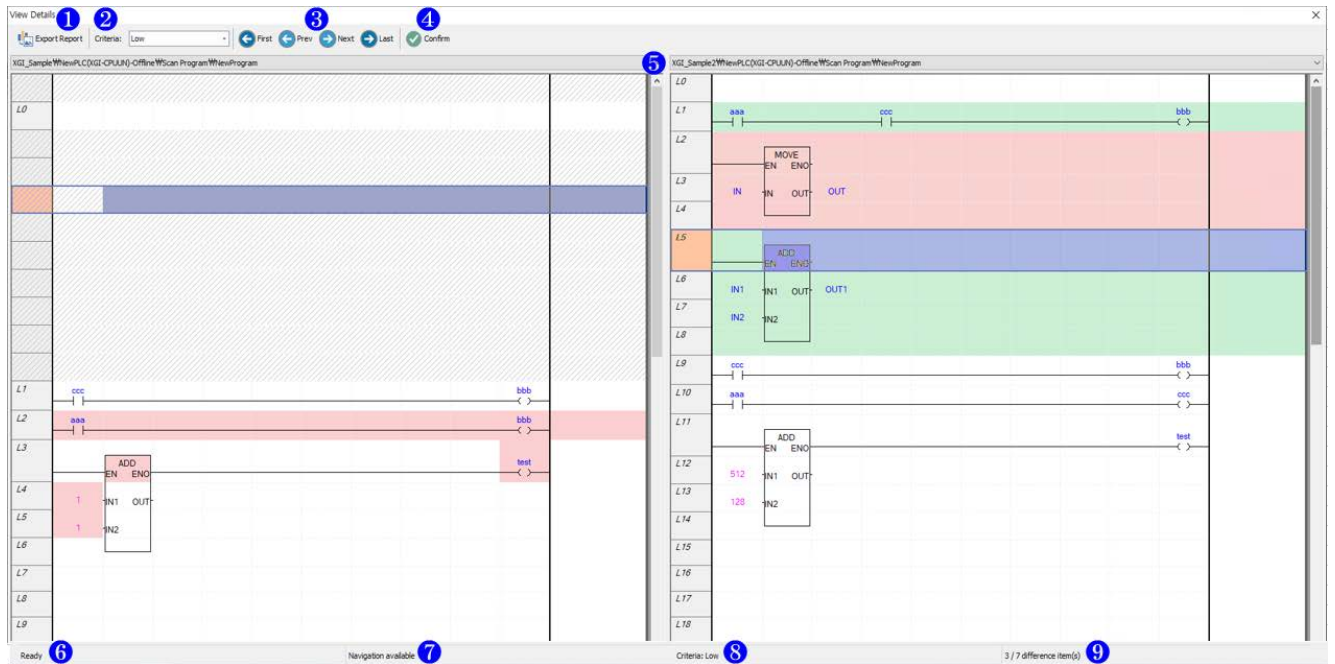

- (1) Export Report: Exports the contents of the [View Details] window as a report file (*.html; including images).
- (2) Criteria(search intensity): Set the intensity to explore visualized differences.
 - Low: Low Intensity (e.g. Searching for Rung Units in LD Programs)
 - Normal: Normal intensity (e.g. Row unit search in LD program)
- (3) Navigation button: Find the differences visualized. Each button is disabled / enabled according to the context.
 - First: Moves to the beginning of the compared differences.
 - Prev: Moves to the previous item based on the currently compared difference.
 - Next: Moves to the next item based on the currently compared differences.
 - Last: Moves to the end of the compared differences.
- (4) Confirm: Exit the [View details] and return to the [Compare Projects] window.
- (5) Combo box: From the selected items in the [Compare Projects] window, you can select items that can be viewed in detail. (Currently only LD available)
- (6) Displays the status of the current detail view window.
- (7) Display navigation-related status.
- (8) Displays the set search intensity.
- (9) Shows the location of the differences you are currently exploring.

Project comparison related functions will be upgraded and additionally developed.

[Notice]

Description of [View Details] (visualization)

- Changed: **(Something)** It means that the compared items are different.
 - ✓ Different parts of detailed comparison items are expressed in red.
 - ✓ If all detailed comparison items are different, the entire row or rung is colored in red.

- Inserted: (Something) It means that it only exists in the current project.
 - ✓ What the user has added to the current project
- Deleted: (Something) It means that it only exists in the project to compare.
 - ✓ The part that is deleted based on the current project in the comparison target project opened by the user.
- Dummy: // In the case of a rung with a different number of source and target project rows, it means the part added to match the pair of rows.
- When exporting the report of the [View details], the image file is stored under the path specified by the user (..WExportResourcesWTime InformationW) and is saved as an HTML file using this.

(8) Added a function to specify the background color of rung comments

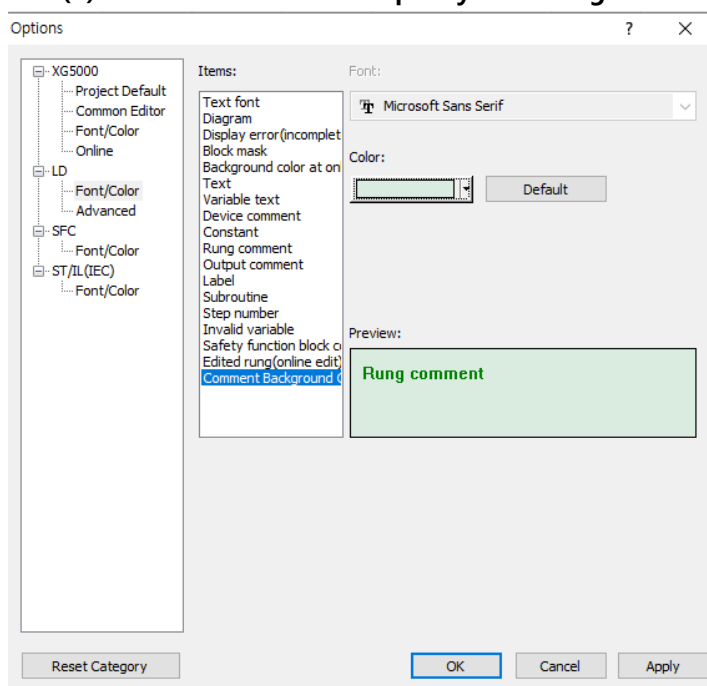

In the LD program, the background color of the comment is displayed in the color set in the option.

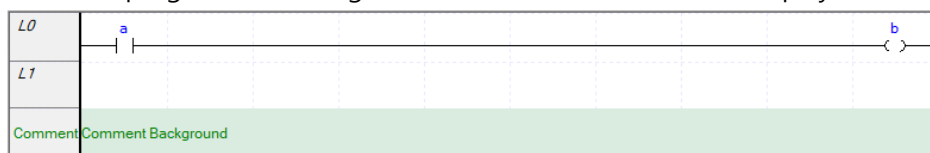

(9) Added a function to input a line in the LD edit window by combining [Ctrl + arrow] keys

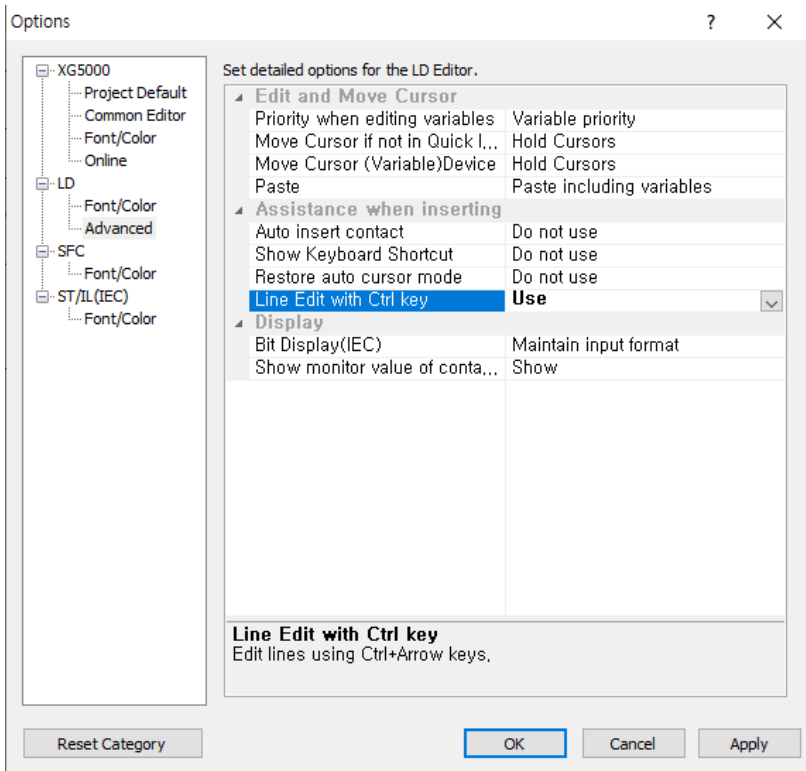

Horizontal or vertical lines can be added by clicking Ctrl + Arrow in the LD edit window.

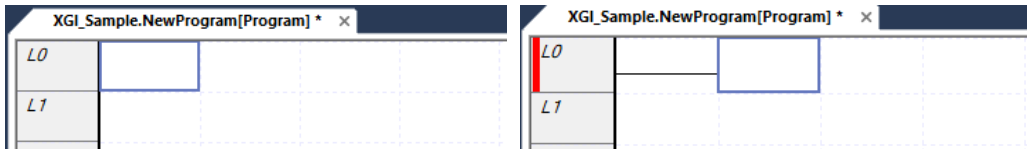

If there is already a line in that direction, it will be deleted.

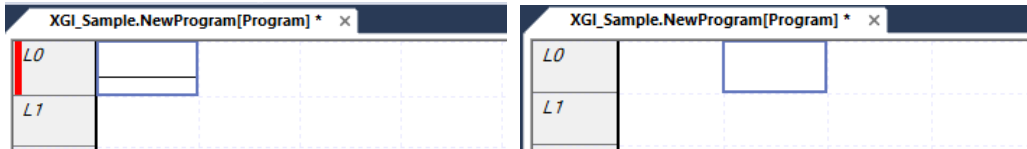

If there are other editing tools (contacts, Function/Function block) other than the line, only the cursor moves.

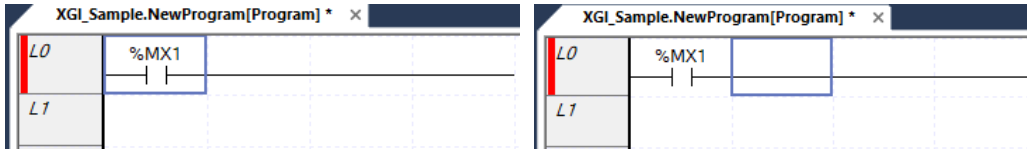

(10) Added automatic English conversion function when inputting a device(XGK)

An option has been added to select whether to automatically switch to English when selecting the device input box in the [Add Variable/Comment] dialog box.

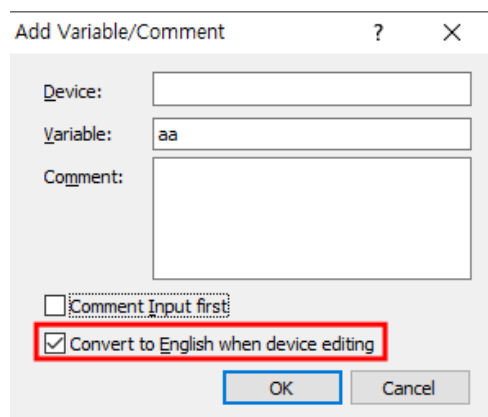
**(11) Added a function to save the last setting state in the [Add Variable/Comment] dialog box**

The function has been improved to remember the settings when the [Add Variable] dialog box is closed and activate the remembered controls when the dialog box is reopened.

(12) Improved find function – Display Function/Function Block

It has been improved to display the Function/Function block used in the search result window. Productivity can be improved by reducing the user's additional action steps while also making it easier to understand what's involved.

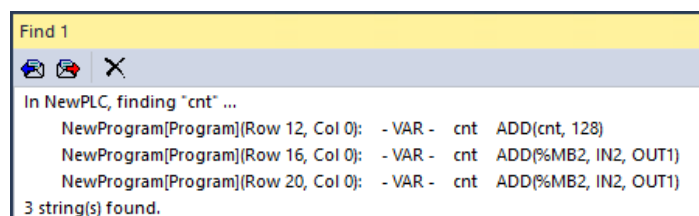
**(13) Improved editing of smart extension variables**

Memory allocation of synchronized global variables in the input/output variable allocation window of Smart Extension has been improved to be editable.

EB No.	Station No/IP	Slot number	Variable name	Type	Device	Monitor value	Comment
1	EB01	1	_0000_EB01_0000_ERR	BOOL	%MX16000		XGF-AV8A (A/D Voltage Input Type)
2			_0000_EB01_0000_RDY	BOOL	%MX16015		Analog Input Module: Error Flag
3			_0000_EB01_0000_CH0_ACT	BOOL	%MX16016		Analog Input Module: CH0 Activatio
4			_0000_EB01_0000_CH1_ACT	BOOL	%MX16017		Analog Input Module: CH1 Activatio
5			_0000_EB01_0000_CH2_ACT	BOOL	%MX16018		Analog Input Module: CH2 Activatio
6			_0000_EB01_0000_CH3_ACT	BOOL	%MX16019		Analog Input Module: CH3 Activatio
7			_0000_EB01_0000_CH4_ACT	BOOL	%MX16020		Analog Input Module: CH4 Activatio
8			_0000_EB01_0000_CH5_ACT	BOOL	%MX16021		Analog Input Module: CH5 Activatio
9			_0000_EB01_0000_CH6_ACT	BOOL	%MX16022		Analog Input Module: CH6 Activatio
10			_0000_EB01_0000_CH7_ACT	BOOL	%MX16023		Analog Input Module: CH7 Activatio
11			_0000_EB01_0000_CH0_DATA	INT	%MW1002		Analog Input Module: CH0 Output
12			_0000_EB01_0000_CH1_DATA	INT	%MW1003		Analog Input Module: CH1 Output
13			_0000_EB01_0000_CH2_DATA	INT	%MW1004		Analog Input Module: CH2 Output
14			_0000_EB01_0000_CH3_DATA	INT	%MW1005		Analog Input Module: CH3 Output
15			_0000_EB01_0000_CH4_DATA	INT	%MW1006		Analog Input Module: CH4 Output
16			_0000_EB01_0000_CH5_DATA	INT	%MW1007		Analog Input Module: CH5 Output
17			_0000_EB01_0000_CH6_DATA	INT	%MW1008		Analog Input Module: CH6 Output
18			_0000_EB01_0000_CH7_DATA	INT	%MW1009		Analog Input Module: CH7 Output
19							

	Variable Kind	Variable	Type	Address	Initial Value	Retain	Used	EIP/OPC UA	HMI	Comment
7	VAR_GLOBAL	_0000_RING_TOPO	BOOL	%LX60149		<input type="checkbox"/>	<input type="checkbox"/>	<input type="checkbox"/>	<input type="checkbox"/>	FEnet: Ring topology state(above Ver 6.0)
8	VAR_GLOBAL	_0000_EB01_0000	INT	%MW1002		<input type="checkbox"/>	<input type="checkbox"/>	<input type="checkbox"/>	<input type="checkbox"/>	Analog Input Module: CH0 Output
9	VAR_GLOBAL	_0000_EB01_0000	ARRAY[0..7]	%MW1002		<input type="checkbox"/>	<input type="checkbox"/>	<input type="checkbox"/>	<input type="checkbox"/>	Analog Input Module: Each CH Output
10	VAR_GLOBAL	_0000_EB01_0000	INT	%MW1003		<input type="checkbox"/>	<input type="checkbox"/>	<input type="checkbox"/>	<input type="checkbox"/>	Analog Input Module: CH1 Output
11	VAR_GLOBAL	_0000_EB01_0000	INT	%MW1004		<input type="checkbox"/>	<input type="checkbox"/>	<input type="checkbox"/>	<input type="checkbox"/>	Analog Input Module: CH2 Output
12	VAR_GLOBAL	_0000_EB01_0000	INT	%MW1005		<input type="checkbox"/>	<input type="checkbox"/>	<input type="checkbox"/>	<input type="checkbox"/>	Analog Input Module: CH3 Output
13	VAR_GLOBAL	_0000_EB01_0000	INT	%MW1006		<input type="checkbox"/>	<input type="checkbox"/>	<input type="checkbox"/>	<input type="checkbox"/>	Analog Input Module: CH4 Output
14	VAR_GLOBAL	_0000_EB01_0000	INT	%MW1007		<input type="checkbox"/>	<input type="checkbox"/>	<input type="checkbox"/>	<input type="checkbox"/>	Analog Input Module: CH5 Output
15	VAR_GLOBAL	_0000_EB01_0000	INT	%MW1008		<input type="checkbox"/>	<input type="checkbox"/>	<input type="checkbox"/>	<input type="checkbox"/>	Analog Input Module: CH6 Output
16	VAR_GLOBAL	_0000_EB01_0000	INT	%MW1009		<input type="checkbox"/>	<input type="checkbox"/>	<input type="checkbox"/>	<input type="checkbox"/>	Analog Input Module: CH7 Output
17	VAR_GLOBAL	_0000_EB01_0000	BOOL	%MX16000		<input type="checkbox"/>	<input type="checkbox"/>	<input type="checkbox"/>	<input type="checkbox"/>	Analog Input Module: Error Flag
18	VAR_GLOBAL	_0000_EB01_0000	BOOL	%MX16015		<input type="checkbox"/>	<input type="checkbox"/>	<input type="checkbox"/>	<input type="checkbox"/>	Analog Input Module: Ready Flag
19	VAR_GLOBAL	_0000_EB01_0000	BOOL	%MX16016		<input type="checkbox"/>	<input type="checkbox"/>	<input type="checkbox"/>	<input type="checkbox"/>	Analog Input Module: CH0 Activation Status
20	VAR_GLOBAL	_0000_EB01_0000	ARRAY[0..7]	%MX16016		<input type="checkbox"/>	<input type="checkbox"/>	<input type="checkbox"/>	<input type="checkbox"/>	Analog Input Module: Each CH Active
21	VAR_GLOBAL	_0000_EB01_0000	BOOL	%MX16017		<input type="checkbox"/>	<input type="checkbox"/>	<input type="checkbox"/>	<input type="checkbox"/>	Analog Input Module: CH1 Activation Status
22	VAR_GLOBAL	_0000_EB01_0000	BOOL	%MX16018		<input type="checkbox"/>	<input type="checkbox"/>	<input type="checkbox"/>	<input type="checkbox"/>	Analog Input Module: CH2 Activation Status
23	VAR_GLOBAL	_0000_EB01_0000	BOOL	%MX16019		<input type="checkbox"/>	<input type="checkbox"/>	<input type="checkbox"/>	<input type="checkbox"/>	Analog Input Module: CH3 Activation Status
24	VAR_GLOBAL	_0000_EB01_0000	BOOL	%MX16020		<input type="checkbox"/>	<input type="checkbox"/>	<input type="checkbox"/>	<input type="checkbox"/>	Analog Input Module: CH4 Activation Status
25	VAR_GLOBAL	_0000_EB01_0000	BOOL	%MX16021		<input type="checkbox"/>	<input type="checkbox"/>	<input type="checkbox"/>	<input type="checkbox"/>	Analog Input Module: CH5 Activation Status
26	VAR_GLOBAL	_0000_EB01_0000	BOOL	%MX16022		<input type="checkbox"/>	<input type="checkbox"/>	<input type="checkbox"/>	<input type="checkbox"/>	Analog Input Module: CH6 Activation Status

(14) Added ARRAY type function for EIP tag (XGK Auto-allocation)

ARRAY type function has been added to enable EIP tag setting in XGK Auto-allocation. The ARRAY type can only be used with EIP tags and cannot be used in programs.

	Variable Kind	Variable	Type	Device	Latch	Used	EIP/OPC UA	HMI	Comment
1	VAR_GLOBAL	aaa	ARRAY[0..9] OF WORD	M0000		<input type="checkbox"/>	<input checked="" type="checkbox"/>	<input type="checkbox"/>	
2	VAR_GLOBAL	bbb	ARRAY[0..9] OF WORD	M0200		<input type="checkbox"/>	<input checked="" type="checkbox"/>	<input type="checkbox"/>	

(15) Added option to use EXTERNAL variable

When using a global variable in an IEC project, it has been improved to select whether to use an External variable in a local variable. This option can be set in [PLC Property].

PLC Property

PLC Options

Sets options for the PLC.

- Basic Settings
 - Variable/Comment Savi... Memory
 - Use External Variable** Disable
 - Multi-User Edit During R... Do not use

Use External Variable
Register global variables into VAR_EXTERNAL or VAR_EXTERNAL_CONST in the local variable window.

(16) Added function to use retain property as default when declaring user function/function block variables(IEC)

Added "Use retain when variable declaration" option in User Function/Function Block [Property] – [Advanced]. If this option is enabled, the retain property is used by default when declaring a variable. It can be used in IEC-type projects.

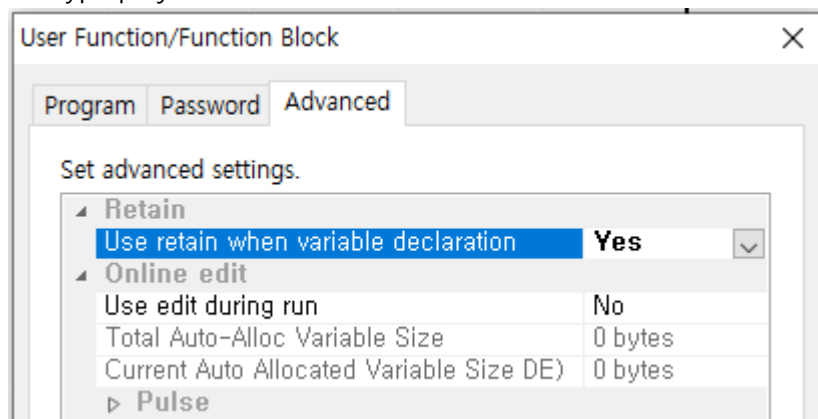

(17) Added [Export into Text File...] and [Import from File...] function in direct variable comments

A function to export/import direct variable comments in the global/direct variable window as a CSV(Comma Separated Values) file has been added.

(18) Added XGF-TC4RT module variable

The following module variables related to input/output alarm have been added.

xx_CHy_IAOFF	Chx Block Input Alarm (OS V3.20 or later)
xx_CHy_OAOFF	Chx Block Output Alarm (OS V3.20 or later)

(19) Remove 10- slot extension base in I/O parameter (XGK, XGI)

Deleted 10-slot extension base that were not sold. The base previously set to 10 slots is maintained.

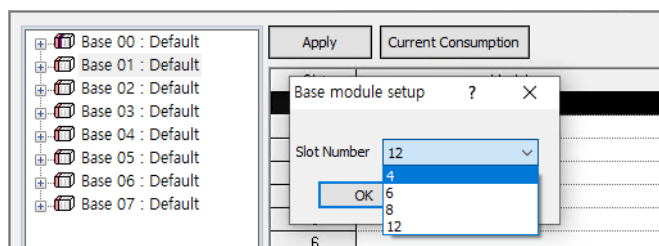

(20) Added power module capacity check function

When writing I/O parameter, a capacity check function has been added.

XG5000



Base 00's current consumption is 4960mA.
Please check the module of each base, it may be the cause of malfunction when the consumption exceeds the limit.

(21) Added NC channel (total 2 channels)

For XMC model, it has been added to set NC channel 2 by adding an additional 1 from the existing 1 NC channel.

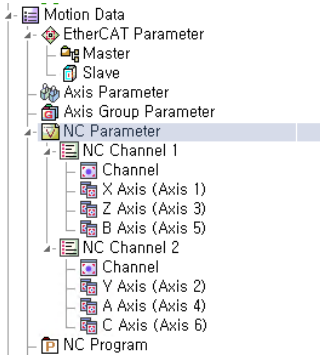

Group	Name	X Axis	Y Axis	Z Axis	A Axis	B Axis	C Axis
Axis	Setting the orientation for the modular	0: Two-way		0: Two-way		0: Two-way	
Origin	Position of 2nd home	0 mm		0 mm		0 mm	
	Position of 3th home	0 mm		0 mm		0 mm	
	Position of 4th home	0 mm		0 mm		0 mm	
Rapid Traverse	Rapid traverse acceleration	500 mm/s ²		500 mm/s ²		500 mm/s ²	
	Rapid traverse deceleration	500 mm/s ²		500 mm/s ²		500 mm/s ²	
	Rapid traverse jerk	0 mm/s ³		0 mm/s ³		0 mm/s ³	
	Rapid traverse speed	10000 mm/m		10000 mm/m		10000 mm/m	
	Dry run speed	10000 mm/m		10000 mm/m		10000 mm/m	
Traverse Area	Min. value of the G22 for the X, Y, Z axis	0 mm		0 mm		0 mm	
	Max. value of the 3rd (X, Y, Z axes)	0 mm		0 mm		0 mm	
	Min. value of the 3rd no-transfer zone range of the X, Y, and Z axes	0 mm		0 mm		0 mm	
	Max. value of the 3rd no-transfer zone range of the X, Y, and Z axes	0 mm		0 mm		0 mm	
Auxiliary Settings	Scaling	0		0		0	
	Overrun amount of positioning in one direction	0 mm		0 mm		0 mm	

Group	Name	X Axis	Y Axis	Z Axis	A Axis	B Axis	C Axis
Axis	Setting the orientation for the modular		0: Two-way		0: Two-way		0: Two-way
Origin	Position of 2nd home		0 mm		0 mm		0 mm
	Position of 3th home		0 mm		0 mm		0 mm
	Position of 4th home		0 mm		0 mm		0 mm
Rapid Traverse	Rapid traverse acceleration		500 mm/s ²		500 mm/s ²		500 mm/s ²
	Rapid traverse deceleration		500 mm/s ²		500 mm/s ²		500 mm/s ²
	Rapid traverse jerk		0 mm/s ³		0 mm/s ³		0 mm/s ³
	Rapid traverse speed		10000 mm/m		10000 mm/m		10000 mm/m
	Dry run speed		10000 mm/m		10000 mm/m		10000 mm/m
Traverse Area	Min. value of the G22 for the X, Y, Z axis		0 mm		0 mm		0 mm
	Max. value of the 3rd (X, Y, Z axes)		0 mm		0 mm		0 mm
	Min. value of the 3rd no-transfer zone range of the X, Y, and Z axes		0 mm		0 mm		0 mm
	Max. value of the 3rd no-transfer zone range of the X, Y, and Z axes		0 mm		0 mm		0 mm
Auxiliary Settings	Scaling		0		0		0
	Overrun amount of positioning in one direction		0 mm		0 mm		0 mm

(22) Improved project read/write function at the same time

When read/write is currently in progress, a function to prevent other users from proceeding with read/write has been added. This function is to prevent simultaneous reading and writing to the same PLC, and it is a function to exclusively block read/write.

User action	Other users
Read	Read - possible
	Write - impossible
Write	Read - impossible
	Write - impossible

If another user reads/writes to the same PLC first, the following dialog box is displayed and you cannot proceed any further.

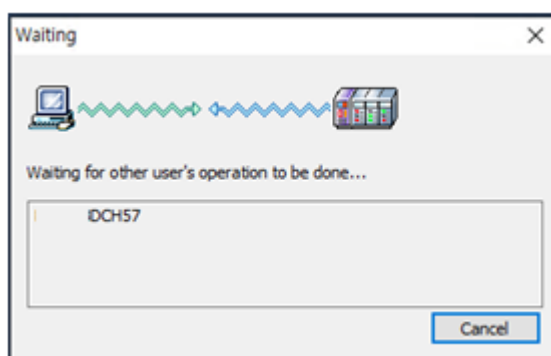

Users who are reading/writing from PLC in use can see who is using the PC name by displaying the PC name. Click [Cancel] to return to the previous state.

If there is no user currently reading/writing, the dialog box is automatically closed and proceeds to the next step.

(23) Use of forced input/output of general devices(XGI-CPUUN)

A function has been added so that a general device can be set as forced I/O. M, W areas are available.

[Settings in the LD editor]

This is how to set general device forced I/O in LD editor.

Place the cursor on the general device for forced I/O setting, and click the Enter key or double-click the mouse.

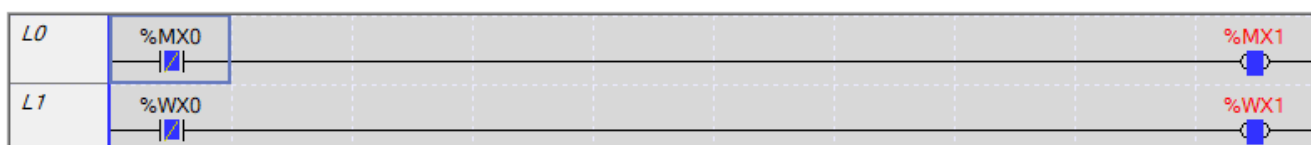

Click the [Foced I/O].

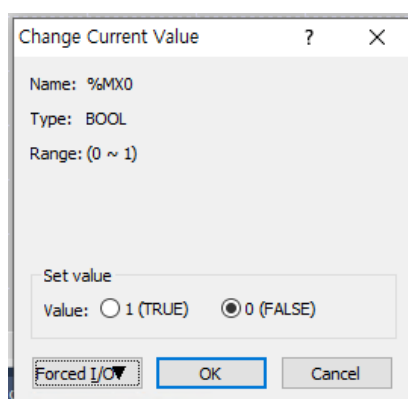

Enter the settings and values in Forced I/O Settings and click [OK].

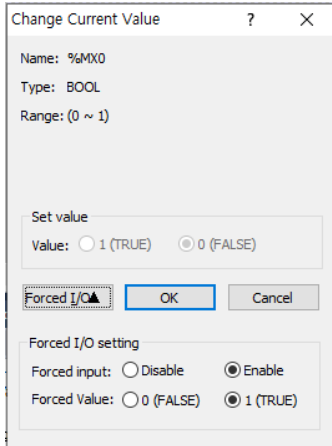

[Smart Extension – Allocate Input/Output Variables]

This is a method to set general device as forced I/O for input/output variables of smart extension.

Double-click Smart Extension in the project tree.

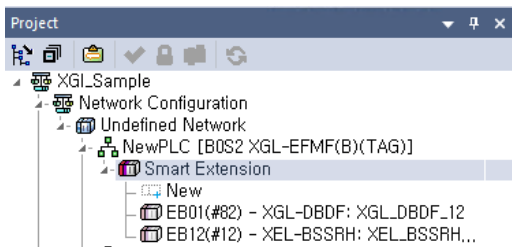

Click [Allocate Input/Output Variables].

EB No.	Station No/IP	Slot number	Variable name	Type	Device	Monitor value	Comment
1	EB01 82	Slot00					XGF-DIV4A (D/A Voltage Output Typ
2			_0002_EB01_0000_CH0_ERR	BOOL	%MX16000	0	Analog Output Module: CH0 Error
3			_0002_EB01_0000_CH1_ERR	BOOL	%MX16001	0	Analog Output Module: CH1 Error
4			_0002_EB01_0000_CH2_ERR	BOOL	%MX16002	0	Analog Output Module: CH2 Error
5			_0002_EB01_0000_CH3_ERR	BOOL	%MX16003	0	Analog Output Module: CH3 Error
6			_0002_EB01_0000_RDY	BOOL	%MX16015	0	Analog Output Module: Ready Flag
7			_0002_EB01_0000_CH0_ACT	BOOL	%MX16016	0	Analog Output Module: CH0 Activati
8			_0002_EB01_0000_CH1_ACT	BOOL	%MX16017	0	Analog Output Module: CH1 Activati
9			_0002_EB01_0000_CH2_ACT	BOOL	%MX16018	0	Analog Output Module: CH2 Activati
10			_0002_EB01_0000_CH3_ACT	BOOL	%MX16019	0	Analog Output Module: CH3 Activati
11			_0002_EB01_0000_OUTEN	WORD	%MW1002	0x0000	Analog Output Module: Output Enab
12			_0002_EB01_0000_CH0_OUTEN	BOOL	%MX16032	0	Analog Output Module: CH0 Output
13			_0002_EB01_0000_CH1_OUTEN	BOOL	%MX16033	0	Analog Output Module: CH1 Output
14			_0002_EB01_0000_CH2_OUTEN	BOOL	%MX16034	0	Analog Output Module: CH2 Output
15			_0002_EB01_0000_CH3_OUTEN	BOOL	%MX16035	0	Analog Output Module: CH3 Output
16			_0002_EB01_0000_CH0_DATA	INT	%MW1003	0x0000	Analog Output Module: CH0 Input
17			_0002_EB01_0000_CH1_DATA	INT	%MW1004	0x0000	Analog Output Module: CH1 Input
18			_0002_EB01_0000_CH2_DATA	INT	%MW1005	0x0000	Analog Output Module: CH2 Input
19			_0002_EB01_0000_CH3_DATA	INT	%MW1006	0x0000	Analog Output Module: CH3 Input
20			_0002_EB01_0000_CH_ERR_ARY	ARRAY[0..3] OF BOOL	%MX16000		Analog Output Module: Each CH Err
25			_0002_EB01_0000_CH_ACT_ARY	ARRAY[0..3] OF BOOL	%MX16016		Analog Output Module: Each CH Act
30			_0002_EB01_0000_CH_OUTEN_ARY	ARRAY[0..3] OF BOOL	%MX16032		Analog Output Module: Each CH Out
35			_0002_EB01_0000_CH_DATA_ARY	ARRAY[0..3] OF INT	%MW1003		Analog Output Module: Each CH In

After placing the cursor on the variable to set [Forced I/O], it can be set by pressing the Enter key or double-clicking the mouse.

The screenshot shows the 'New PLC [B052 EB01(#82)] - XGL-DBDF: XGL-DBDF_12' window. The main table lists variables for Slot 00 and Slot 01. A dialog box titled 'Change Current Value' is open, showing the name '%MX16032', type 'BOOL', and range '(16#00 ~ 16#01)'. The 'Set value' section has 'Value: 1 (TRUE)' selected. The 'Forced I/O' checkbox is checked.

EB No.	Station No/IP	Slot number	Variable name	Type	Device	Monitor value	Comment
1	EB01	82	Slot00				XGF-DV4A (D/A Voltage Output Typ
2			_0002_EB01_0000_CH0_ERR	BOOL	%MX16000	0	Analog Output Module: CH0 Error
3			_0002_EB01_0000_CH1_ERR	BOOL	%MX16001	0	Analog Output Module: CH1 Error
4			_0002_EB01_0000_CH2_ERR	BOOL	%MX16002	0	Analog Output Module: CH2 Error
5			_0002_EB01_0000_CH3_ERR	BOOL	%MX16003	0	Analog Output Module: CH3 Error
6			_0002_EB01_0000_RDY	BOOL	%MX16015	0	Analog Output Module: Ready Flag
7			_0002_EB01_0000_CH0_ACT	BOOL	%MX16016	0	Analog Output Module: CH0 Activati
8			_0002_EB01_0000_CH1_ACT	BOOL	%MX16017	0	Analog Output Module: CH1 Activati
9			_0002_EB01_0000_CH2_ACT	BOOL	%MX16018	0	Analog Output Module: CH2 Activati
10			_0002_EB01_0000_CH3_ACT	BOOL	%MX16019	0	Analog Output Module: CH3 Activati
11			_0002_EB01_0000_OUTEN	WORD	%MW1002	0x0000	Analog Output Module: Output Enab
12			_0002_EB01_0000_CH0_OUTEN	BOOL	%MX16032	0	Analog Output Module: CH0 Output
13			_0002_EB01_0000_CH1_OUTEN	BOOL	%MX16033	0	Analog Output Module: CH1 Output
14			_0002_EB01_0000_CH2_OUTEN	BOOL	%MX16034	0	Analog Output Module: CH2 Output
15			_0002_EB01_0000_CH3_OUTEN	BOOL	%MX16035	0	Analog Output Module: CH3 Output
16			_0002_EB01_0000_CH0_DATA	INT	%MW1003	0x0000	Analog Output Module: CH0 Input
17			_0002_EB01_0000_CH1_DATA	INT	%MW1004	0x0000	Analog Output Module: CH1 Input
18			_0002_EB01_0000_CH2_DATA	INT	%MW1005	0x0000	Analog Output Module: CH2 Input
19			_0002_EB01_0000_CH3_DATA	INT	%MW1006	0x0000	Analog Output Module: CH3 Input
20			_0002_EB01_0000_CH_ERR_ARY	ARRAY[0..3] OF BOOL	%MX16000		Analog Output Module: Each CH Err
25			_0002_EB01_0000_CH_ACT_ARY	ARRAY[0..3] OF BOOL	%MX16016		Analog Output Module: Each CH Act
30			_0002_EB01_0000_CH_OUTEN_ARY	ARRAY[0..3] OF BOOL	%MX16032		Analog Output Module: Each CH Out
35			_0002_EB01_0000_CH_DATA_ARY	ARRAY[0..3] OF INT	%MW1003		Analog Output Module: Each CH In
41			Slot01				XGF-DC8A (D/A Current Output Typ
42			_0002_EB01_0001_CH0_ERR	BOOL	%MX16000	0	Analog Output Module: CH0 Error
43			_0002_EB01_0001_CH1_ERR	BOOL	%MX16001	0	Analog Output Module: CH1 Error

Also, you can set forced I/O for each slot at once. Right-click the mouse - Click [Set Forced I/O].

The screenshot shows the same variable table as above. A right-click context menu is open over the 'Monitor value' column. The menu items are: 'Set Forced I/O', 'Cut', 'Copy', 'Paste', 'Delete', 'Expand all variables', and 'Collapse all variables'. The 'Set Forced I/O' option is highlighted.

All BIT type variables of the currently selected slot are displayed in the forced I/O setting dialog box.

- You can check the position you want to set through the EB number and slot number.
- It is possible to set whether to use the general device forced I/O by checking/unchecking the general device permission.

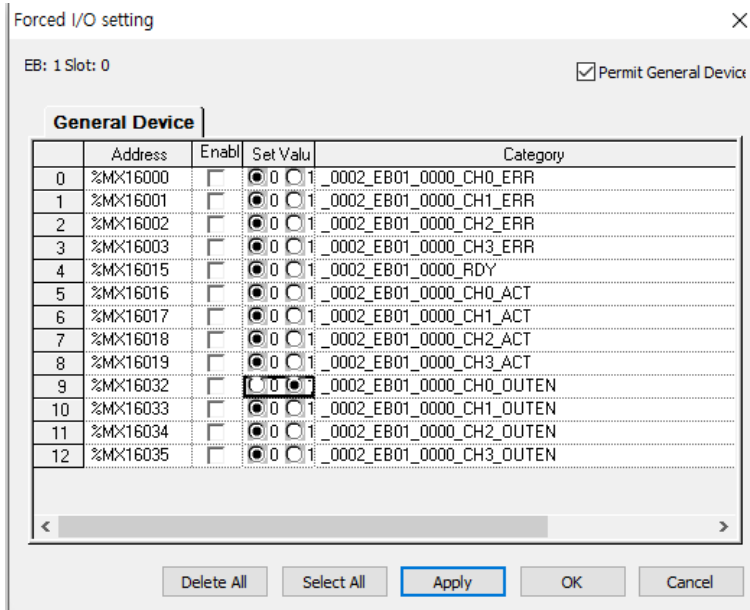

If you click [Select All], all devices are set to forced I/O.

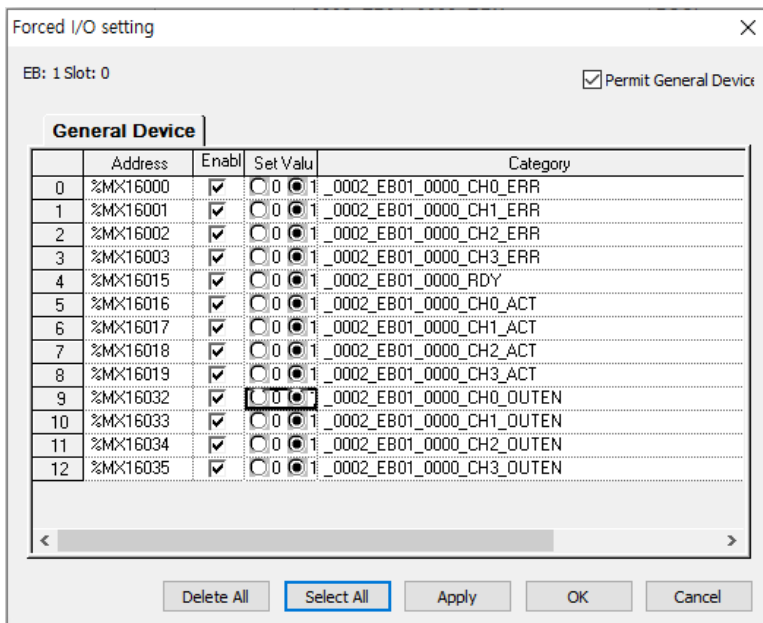

If you click [Delete All], all devices set for forced I/O are deleted.

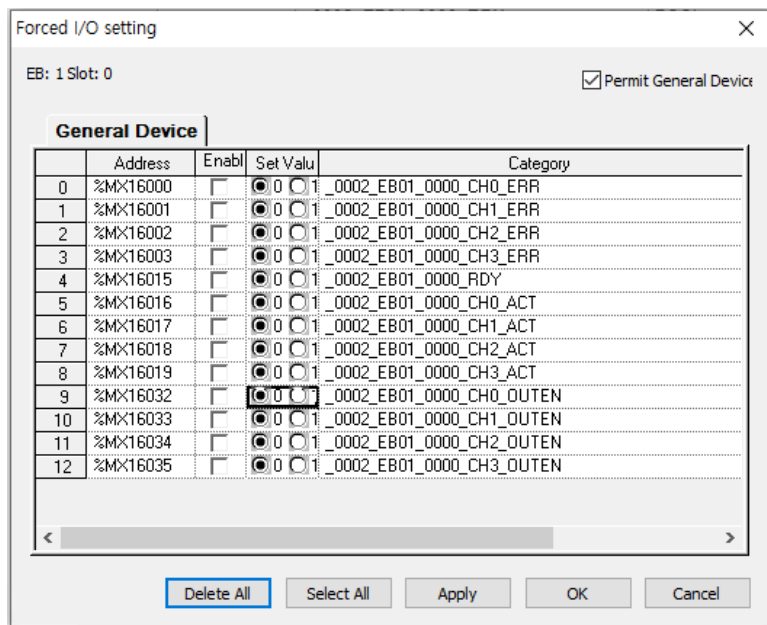

If you click the [OK] or [Apply] button, the set forced I/O is downloaded to PLC.

For I/Q devices, the existing forced I/O setting dialog box is displayed.

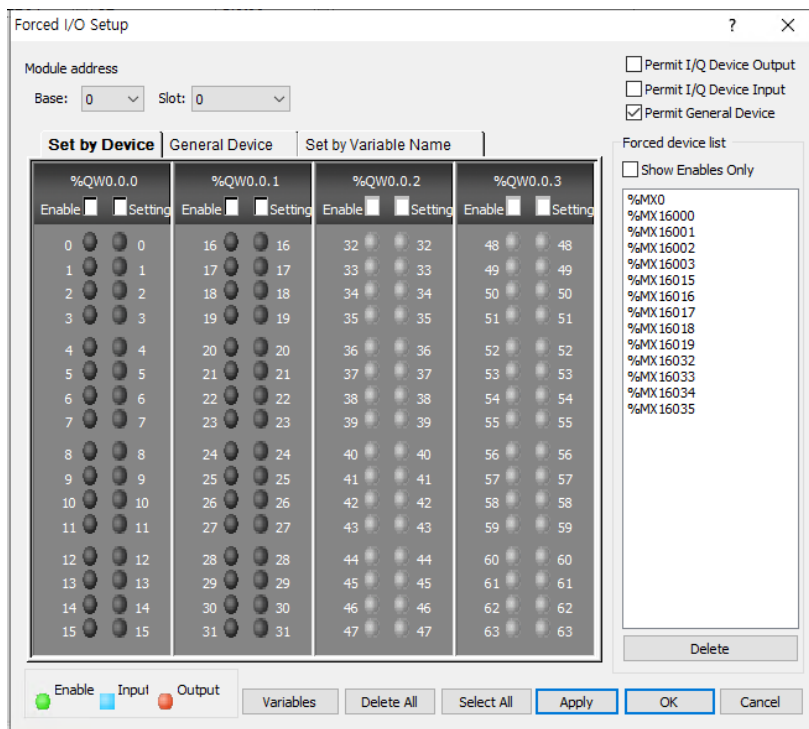

Check the [Forced I/O Setup]

How to check the set general device forced I/O.

Click [Online] - [Forced I/O Setup].

You can check the set general device Forced I/O by moving to [General device] tab.

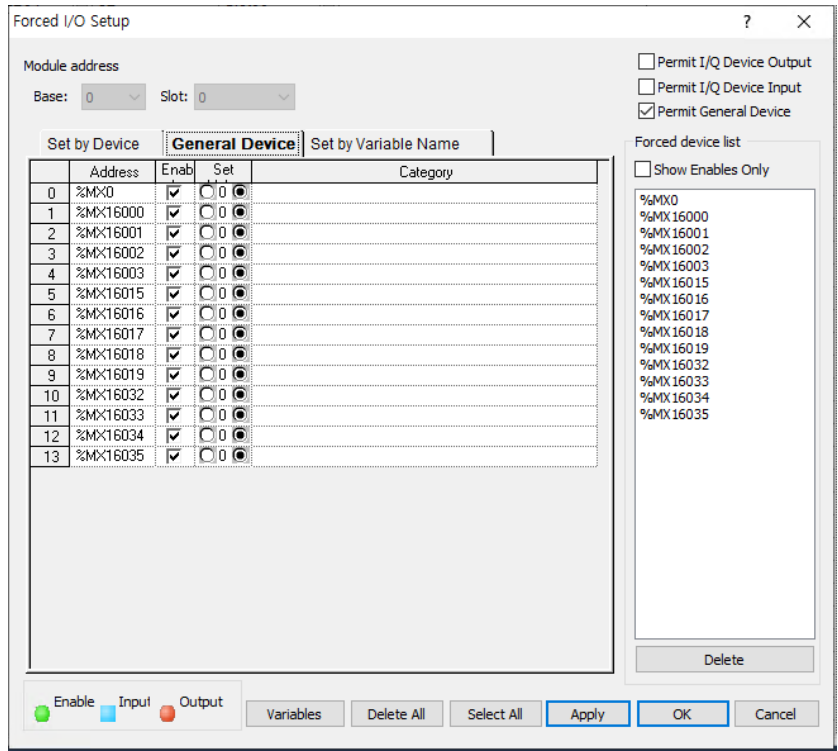

By clicking [Delete All], you can delete all general device forced I/O set so far.

[Notice]

[Delete All] and [Select All] will delete and select I and Q devices as well.

After selecting the device you want to delete from the set devices, you can selectively delete it by clicking the [Delete] button.

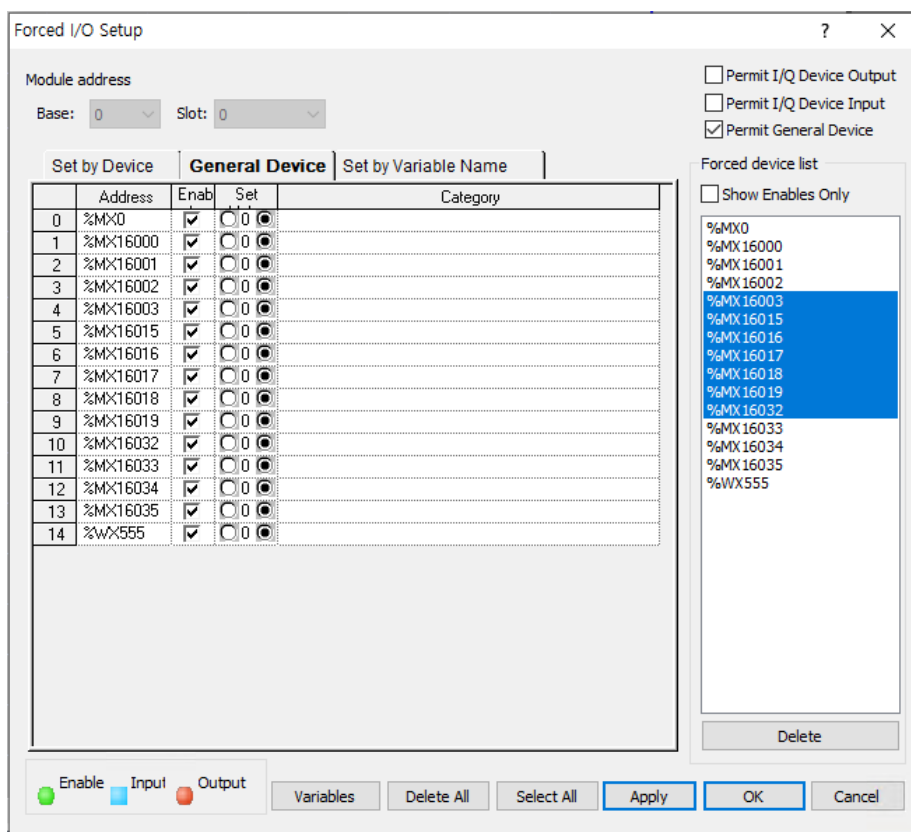

[Notice]

If you enable [Options] - [Online] - [Monitoring Forced I/O Status] option, you can easily check the forced I/O set in the LD edit window and the input/output variable assignment window.

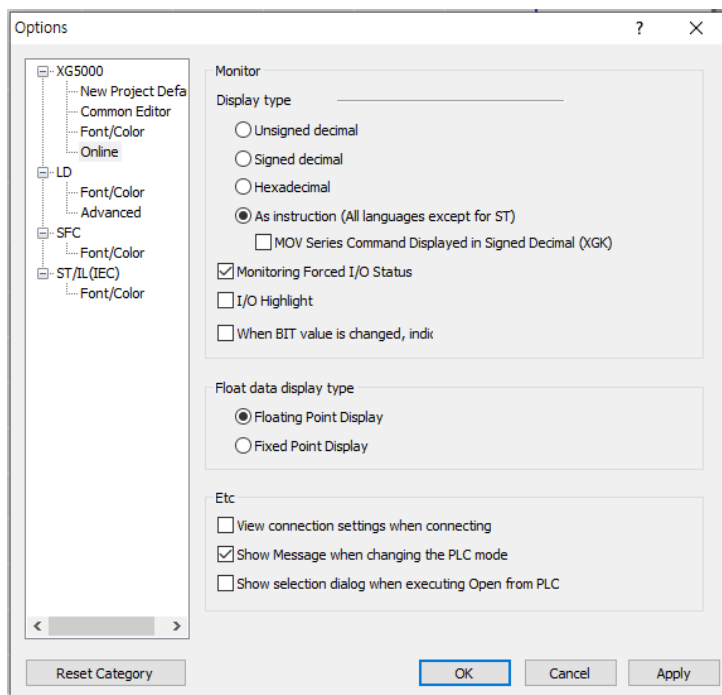

In the LD edit window

- When the setting is "Allow", the background is yellow.
- When the value is "1(TRUE)", the background is displayed in green.

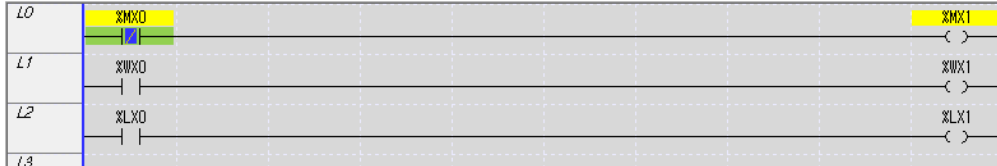

In [Allocate Input/Output Variables], when the setting is "Allow", the background is yellow.

EB No.	Station No/IP	Slot number	Variable name	Type	Device	Monitor value	Comment
113			_0002_EB04_0001_CH6_ACT	BOOL	%MX128534	0	Analog Output Module: CH6 Activati
114			_0002_EB04_0001_CH7_ACT	BOOL	%MX128535	0	Analog Output Module: CH7 Activati
115			_0002_EB04_0001_OUTEN	WORD	%MW8034	0x007F	Analog Output Module: Output Enab
116			_0002_EB04_0001_CH0_OUTE	BOOL	%MX128544	1	Analog Output Module: CH0 Output
117			_0002_EB04_0001_CH1_OUTE	BOOL	%MX128545	1	Analog Output Module: CH1 Output
118			_0002_EB04_0001_CH2_OUTE	BOOL	%MX128546	1	Analog Output Module: CH2 Output
119			_0002_EB04_0001_CH3_OUTE	BOOL	%MX128547	1	Analog Output Module: CH3 Output
120			_0002_EB04_0001_CH4_OUTE	BOOL	%MX128548	1	Analog Output Module: CH4 Output
121			_0002_EB04_0001_CH5_OUTE	BOOL	%MX128549	1	Analog Output Module: CH5 Output
122			_0002_EB04_0001_CH6_OUTE	BOOL	%MX128550	1	Analog Output Module: CH6 Output
123			_0002_EB04_0001_CH7_OUTE	BOOL	%MX128551	0	Analog Output Module: CH7 Output

(24) Improved to maintain user data type memory allocation.

When memory is allocated using a variable as a user data type, the memory allocation of the member variable is maintained even if the member variable name is changed in the user data type.

Ex) Memory allocation is maintained even if the member variable of the user data type is changed from "RESERVED" to "RES".

User-defined Data Type Select Item

The sub-item of the variable "NEW", the type "TEST" is selected.

Variable	Type	Address	Initial Value
1	NEW.RESERVED0	ARRAY[0..7] %MW500	
2	NEW.RESERVED0[0]	WORD %MW500	
3	NEW.RESERVED0[1]	WORD %MW501	
4	NEW.RESERVED0[2]	WORD %MW502	
5	NEW.RESERVED0[3]	WORD %MW503	
6	NEW.RESERVED0[4]	WORD %MW504	
7	NEW.RESERVED0[5]	WORD %MW505	
8	NEW.RESERVED0[6]	WORD %MW506	
9	NEW.RESERVED0[7]	WORD %MW507	
10	NEW.RESERVED1	ARRAY[0..5] %MB1016	
11	NEW.RESERVED1[0]	USINT %MB1016	
12	NEW.RESERVED1[1]	USINT %MB1017	
13	NEW.RESERVED1[2]	USINT %MB1018	
14	NEW.RESERVED1[3]	USINT %MB1019	
15	NEW.RESERVED1[4]	USINT %MB1020	
16	NEW.RESERVED1[5]	USINT %MB1021	
17	NEW.RESERVED2	ARRAY[0..5] %MB1022	
18	NEW.RESERVED2[0]	USINT %MB1022	
19	NEW.RESERVED2[1]	USINT %MB1023	
20	NEW.RESERVED2[2]	USINT %MB1024	
21	NEW.RESERVED2[3]	USINT %MB1025	
22	NEW.RESERVED2[4]	USINT %MB1026	

User-defined Data Type Select Item

The sub-item of the variable "NEW", the type "TEST" is selected.

Variable	Type	Address	Initial Value
1	NEW.RES0	ARRAY[0..7] %MW500	
2	NEW.RES0[0]	WORD %MW500	
3	NEW.RES0[1]	WORD %MW501	
4	NEW.RES0[2]	WORD %MW502	
5	NEW.RES0[3]	WORD %MW503	
6	NEW.RES0[4]	WORD %MW504	
7	NEW.RES0[5]	WORD %MW505	
8	NEW.RES0[6]	WORD %MW506	
9	NEW.RES0[7]	WORD %MW507	
10	NEW.RES4	ARRAY[0..5] %MB1016	
11	NEW.RES4[0]	USINT %MB1016	
12	NEW.RES4[1]	USINT %MB1017	
13	NEW.RES4[2]	USINT %MB1018	
14	NEW.RES4[3]	USINT %MB1019	
15	NEW.RES4[4]	USINT %MB1020	
16	NEW.RES4[5]	USINT %MB1021	
17	NEW.RES5	ARRAY[0..5] %MB1022	
18	NEW.RES5[0]	USINT %MB1022	
19	NEW.RES5[1]	USINT %MB1023	
20	NEW.RES5[2]	USINT %MB1024	
21	NEW.RES5[3]	USINT %MB1025	

(25) Option to change monitor current value.

An option setting has been added to display the previous value when the current value of the bit device is changed during program monitoring. This option can be set in [TOOLS]-[Options].

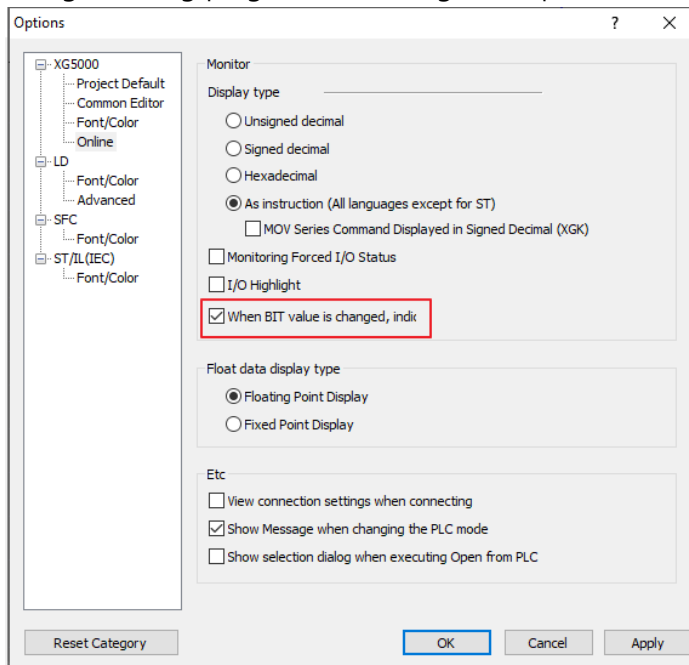

Default: Don't show as current value (show inverted value)

If the option is set, the current value is displayed when the current value is changed.

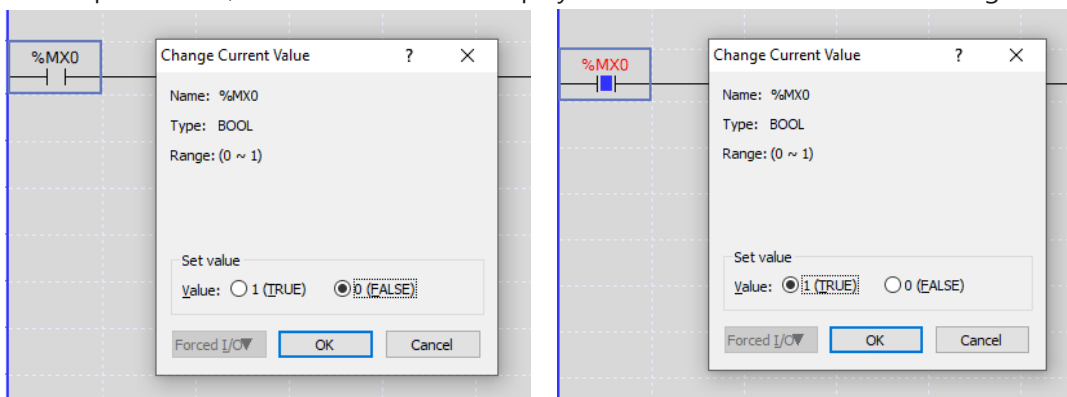

(26) Improvement of the expression method for variable types in the hierarchical structure in the [Monitor] window.

PLC	Program	Variable/Device	Value	Type	Device/Variable
NewPLC	<GLOBAL>	Axis_Monitoring		Axis_monitor	
		Axis_Monitoring.ECODE_SV		Servo_Teaching	
		Axis_Monitoring.ECODE_SV.Save_Position		Servo_Lamp	
		Axis_Monitoring.ECODE_SV.Save_Position.RESERVED0		ARRAY[0..7] OF WORD	
		Axis_Monitoring.ECODE_SV.Save_Position.RESERVED0[0]		WORD	
		Axis_Monitoring.ECODE_SV.Save_Position.RESERVED0[1]		WORD	
		Axis_Monitoring.ECODE_SV.Save_Position.RESERVED0[2]		WORD	
		Axis_Monitoring.ECODE_SV.Save_Position.RESERVED0[3]		WORD	
		Axis_Monitoring.ECODE_SV.Save_Position.RESERVED0[4]		WORD	
		Axis_Monitoring.ECODE_SV.Save_Position.RESERVED0[5]		WORD	
		Axis_Monitoring.ECODE_SV.Save_Position.RESERVED0[6]		WORD	
		Axis_Monitoring.ECODE_SV.Save_Position.RESERVED0[7]		WORD	
		Axis_Monitoring.ECODE_SV.Save_Position.RESERVED1		ARRAY[0..5] OF USINT	
		Axis_Monitoring.ECODE_SV.Save_Position.RESERVED2		ARRAY[0..5] OF USINT	
		Axis_Monitoring.ECODE_SV.Save_Position.RESERVED3		ARRAY[0..5] OF USINT	
		Axis_Monitoring.ECODE_SV.Save_Position.RESERVED4		ARRAY[0..5] OF USINT	
		Axis_Monitoring.ECODE_SV.Save_Position.RESERVED5		ARRAY[0..5] OF USINT	

By applying the expression method according to the depth of the hierarchy, it has been improved to more clearly understand the hierarchical structure in the [monitor] window.

[Remark]

- After selecting a variable, right-click the mouse and select [Add to Variable Monitor] or [Add to Current Variable Monitor] to monitor.
- In the case of added hierarchical type variables, you can expand/reduce them by using the [+]/[-] buttons in the monitor window.

(27) Modbus communication address improvement with our inverter(drive).

When setting the inverter variable, the same address as the inverter instruction manual is displayed. The address used in actual communication is "Address - 1", but it has been modified so that communication is possible without "Address -1".

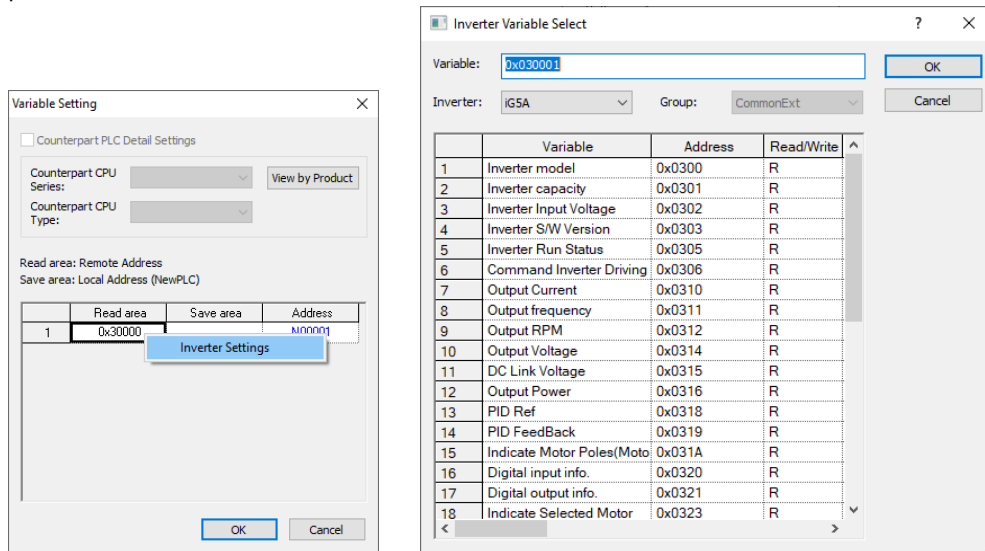

(28) "Pt1000" sensor type added to the input parameter of XBF-TC04RT in XG-TCON.

In XG-TCON, "Pt1000" sensor type is added to the input parameter of XBF-TC04RT. This function is supported from XBF-TC04RT module firmware V1.50, and temperature conversion is not performed when "Pt1000" is set in module firmware V1.40 or lower.

Parameter setting -New

Parameter	Type	LOOP0	LOOP1	LOOP2	LOOP3
Input type	<input type="checkbox"/> Input type	Pt100: -200 ~ 850 °C	Pt100: -200 ~ 850 °C	Pt100: -200 ~ 850 °C	Pt100: -200 ~ 850 °C
	<input type="checkbox"/> Short circuit	Pt100: -200 ~ 850 °C	Permission	Permission	Permission
	Upper limit of effective input	JPt100: -200 ~ 600 °C Pt1000: -200 ~ 850 °C	850.0	850.0	850.0
	Lower limit of effective input	-200.0	-200.0	-200.0	-200.0
	Upper limit of scale	850.0	850.0	850.0	850.0
	Lower limit of scale	-200.0	-200.0	-200.0	-200.0

(29) Added EDS Revision No. check function to XG-CANopen.

The function to set whether to check product code and Revision No. in XG-CANopen has been added. The default values are shown in the figure below. (Compatibility with existing products)

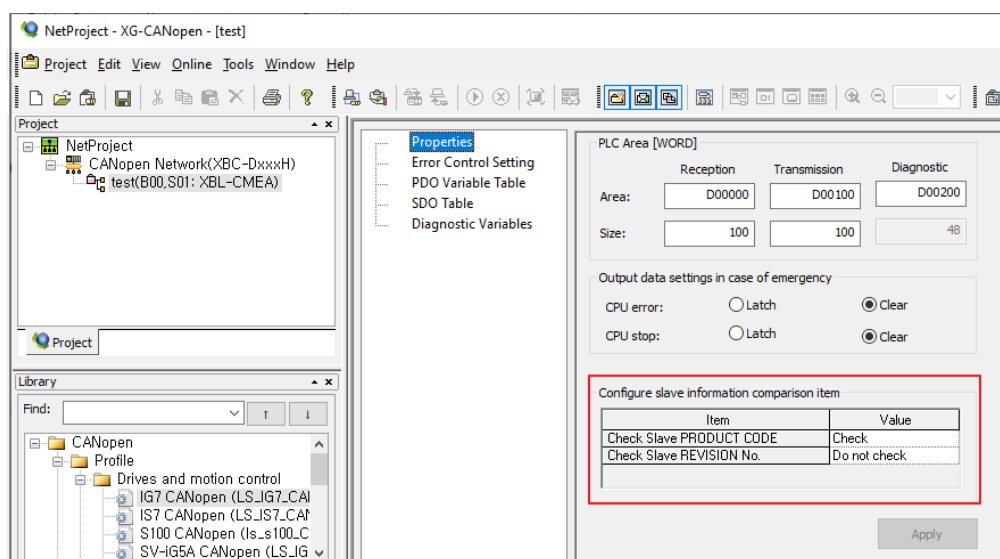

※ The revision check function is supported from XBL-CMEA V1.40.

(30) "CRC16 CCITT FALSE" BCC item added.

"CRC16 CCITT FALSE" item has been added to BCC setting of user frame definition for Cnet module.

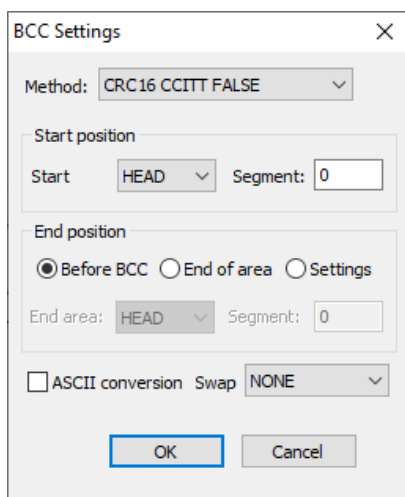

(31) Improved XGL-EFMTB timeout setting.

The server/client timeout setting range has been improved. It can be set in 1 second or 10 millisecond increments. For details, refer to the product user manual.

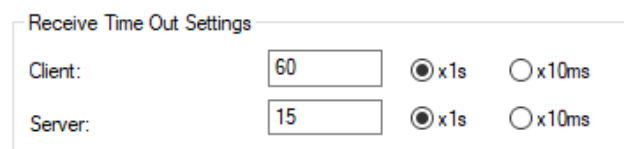

(32) Improved XGL-RMEB slave communication error handling.

In case of communication error with the connected slave, a processing method for input data has been added. For details, refer to the product user manual.

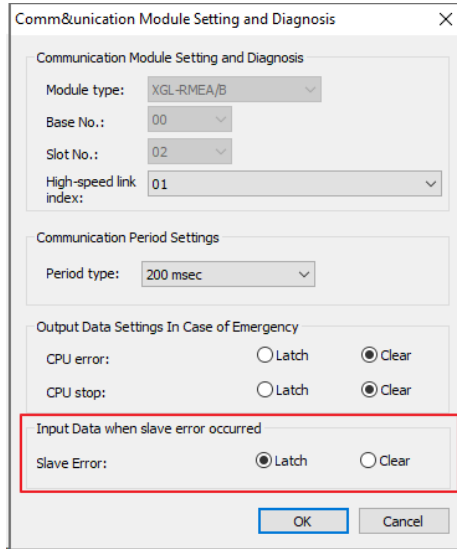

(33) Input data item is added to Dnet master property in nConfigurator.

When the master cable is removed, an option to choose whether to keep or clear the input data has been added.

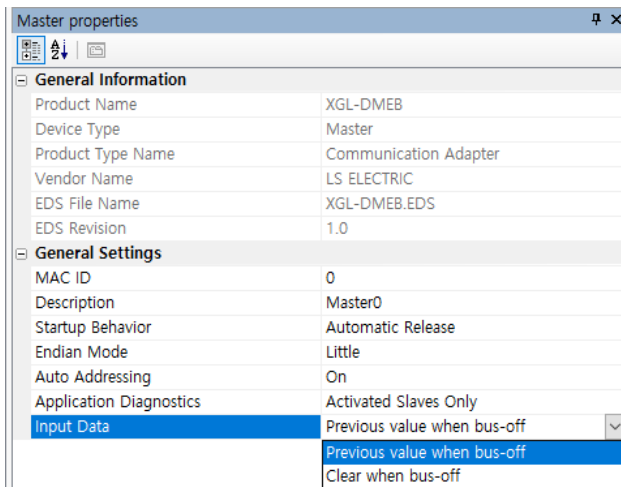

(34) Improved RAPIenet+ auto scan comparison function.

Improvements have been made to compare EIP devices when clicking compare in RAPIenet+ Auto Scan.

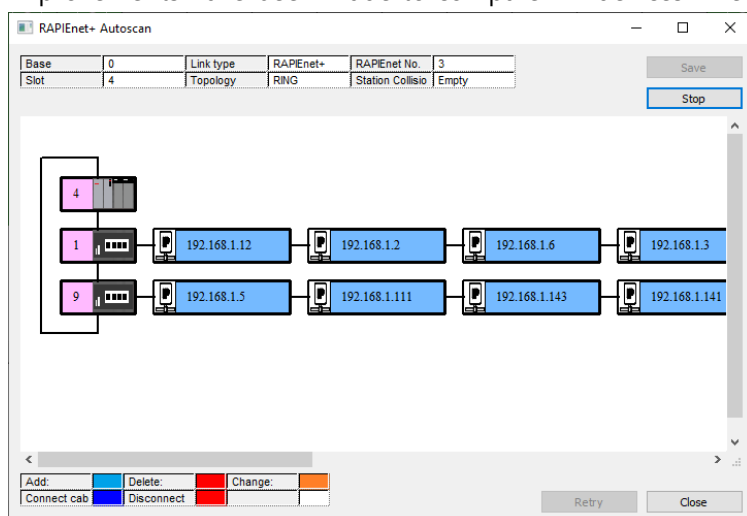
**(35) Diagnosis function of extension slave has been added.**

1. Click [Online]-[Communication module setting and diagnosis]-[System Diagnosis] of the XG5000 menu.

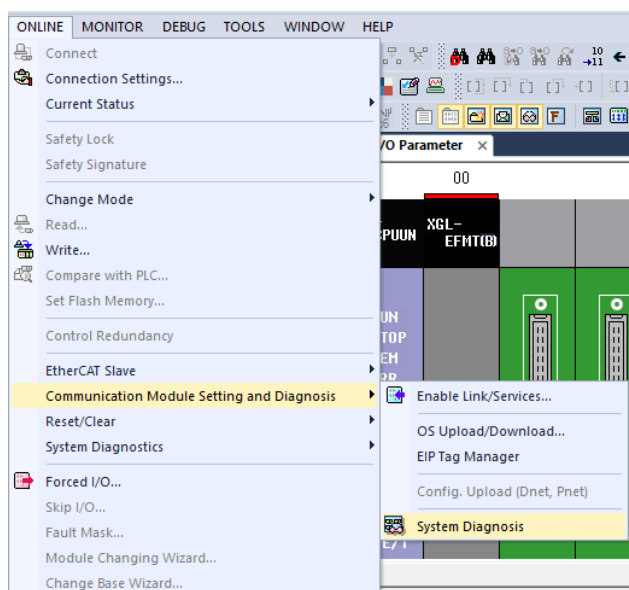

2. If you right-click the mouse after placing the cursor on the module, the available diagnostic functions are displayed.

The supported features are:

- Slave Module Information
- Media Information
- RAPIenet media information
- View Communication Module Log
- Save Communication Module Log

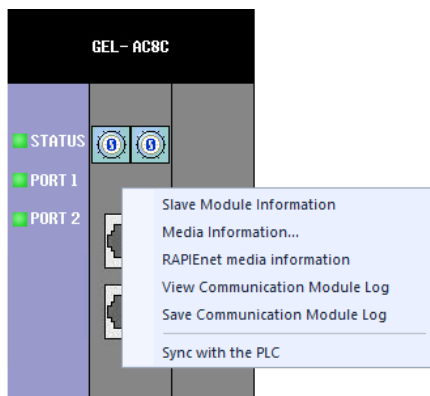
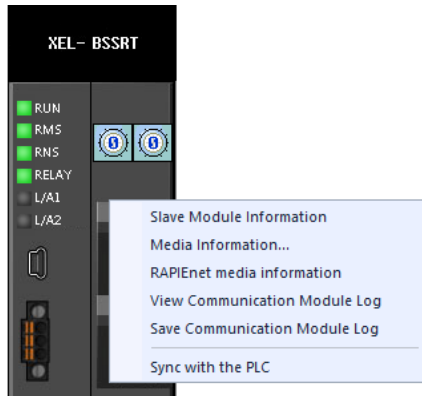
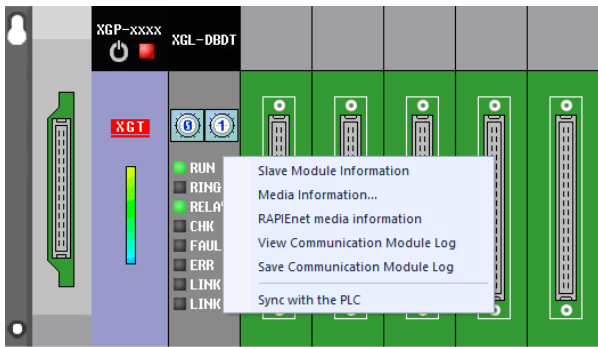

(36) EIP view function added

Additional diagnostic information is displayed.

In addition to the existing IP information, Vendor Code, Device Type, Product Code, and Revision information are additionally displayed. You can insert any icon you want.

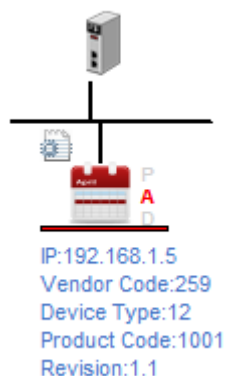

[Remark]

- The default icon (PLC icon) is displayed unless the user sets the icon separately.

(37) Improvements related to multidimensional arrays

Improvements have been made so that multidimensional arrays can be used in the array command.

(38) Added new command

The following commands have been added. Please refer to the user manual for details.

Array comparison - ANY_CMP, ANY_CMP_EQ, ANY_CMP_NE

Positioning related commands – Buffering operation commands, a non-preemptive operating commands

Serial communication (Cnet) module setting command – SET_CNET_PARAM, GET_CNET_PARAM

General communication module setting command(XGK-CPUHN) - CPMSG

(39) Add module - XGF-PN16B (Standard positioning EtherCAT network type, 16 axes)

- Supports module setting function according to the release of XGF-PN16B module.

2. Error Correction

(1) Fixed the problem of timer/counter error in XGK Auto-allocation project.

The problem that is displayed as an error when a timer/counter type variable declared as WORD type in the XGK Auto-allocation project is used for the contact point in the LD program has been fixed.

(2) Fixed the problem of monitoring error when array type variable of user function block is used.

The problem that the array value is displayed incorrectly in the monitor mode when the array type is used in the VAR_INPUT and VAR_IN_OUT parameters of the user function block has been fixed.

(3) Fixed global/direct variable window update error.

The problem that the direct variable comment window is not immediately updated when reading large comment (direct variable) has been fixed.

(4) Fixed an error in which all contents of the device description were deleted when the PLC type was changed.

In the case of XGK programming (Auto-allocation) project, the problem that all contents of device comments are deleted when PLC type is changed has been fixed.

(5) Fixed an error in the search operation in the global/direct variable window

The problem that the device cannot be moved to the device when a variable is entered after selecting "Declared List" in the global/direct variable window has been fixed.

(6) Fixed an error where the editor was not activated when the Find/Replace window was closed with the ESC key.

The problem that the editor was not activated again when the Find/Replace window was not pinned and the window was closed by pressing the ESC key has been fixed.

(7) Correction of ANY_PTR type command problem

Fixed a problem with the ANY_PTR type command.

- Problem when using ANY_PTR type instruction for VAR_INPUT and VAR_IN_OUT of user function/function block
- Problems when using a variable that has an array as a structure member in an ANY_PTR type instruction.

(8) Fixed XGL-PMEB Sendix Multiturn Encoder slave problem.

The problem that communication was not working properly when downloading by adding Sendix Multiturn Encoder slave to XGL-PMEB module in nConfigurator has been fixed.

(9) Fixed an error displaying I/O module names

Fixed a problem that displays internal I/O for block type PLC as 'Unknown', and synchronizing with I/O parameters.

(10) Fixed an error saving Variable/Comment

Fixed a problem missing edited Variable/Comment if currently editing window closed

(11) Fixed an error in checking constant (false negative)

Constant used an input variable in user function and function block in XGK Auto-Allocation type, displays an error even though the data type is compatible.

(12) Fixed an error in the XMC EtherCAT parameter information configuration

Fixed a problem with configuring EtherCAT parameters Syncmanager information applied to the XMC.

(13) Fixed an error that did not save when "reading text file" in direct variable comments

Fixed the problem that when the project is closed immediately, it is not saved in the project because the saving or not is not changed after "reading text file" in the direct variable comment window.

(14) Fixed an error about Find/Replace

The problem that the device used in the program cannot be found has been fixed when a device is entered in Find what in the Find/Replace Device window. (XGI project)

(15) Fixed an error of memory allocation in the user data type item setting

When copying and pasting from an Excel file to set the memory allocation of member variables in the dialog box, the problem of pasting into the memory allocation column of array member variables has been fixed. Memory allocation is possible only at the start address of the array, and the user cannot allocate memory for array member variables. (XGI project)

(16) Fixed an error of the input type in DECO Function

An error where input variable type other than INT type was input in the DECO function has been fixed.

(17) Fixed an error of "online force edit"

The problem that a communication error message occurs when executing "online force edit" has been fixed.

(18) Fixed a XMC index variable error

If the variable used as the index of the array is set to retain, the problem that the program is not displayed normally when opened from PLC has been fixed.

(19) Fixed an error of global variable memory reference

If local and global variables are used as the same variable, an error where data was incorrectly displayed when referring to memory has been fixed.

(20) Fixed an error about an array type of UDFB

The problem that the first WORD is initialized to 0 when an array is used as VAR_INPUT of the user function block has been fixed.

(21) Fixed an error of nConfigurator slave setting

The problem that the parameter length is calculated incorrectly when setting multiple duplicate modules has been fixed.

3. XG-PM

(1) Added Cam block editor(XGF-M32E)

- The cam block function creates a cam profile by setting the cam curve, connection speed, connection acceleration, and connection jerk. Added the following features.

- [CAM block editor]

The screenshot displays the 'New CAM block' editor window. At the top, there are input fields for 'Cam velocity [Units]', 'Sub. Ax. Max. Vel. [Units]', 'Sub. Ax. Max. Acc. [Units]', and 'Sub. Ax. Max. Jerk [Units]'. Below these are checkboxes for 'Cam curve', 'Con. speed', 'Con. Accel', and 'Con. jerk'. A table lists cam nodes with columns for 'Main Ax. Pos.', 'Sub. Ax. Pos.', 'Cam curve', 'Con. speed', 'Con. Accel', 'Con. jerk', 'Points', and 'Intr. methd'. At the bottom, a graph shows 'Position', 'Speed', 'Acceleration', and 'Jerk' curves over time. Callout boxes on the right identify 'CAM block property setting', 'CAM node setting', and 'CAM graph setting'.

- [Cam block operation function block]

Provides the ability to read/write/save cam blocks and create cam profiles while driving.

	Cam block operation command	function
1	LS_READCAMBLOCPROPERTY	Read specified cam block properties
2	LS_WRITECAMBLOCPROPERTY	Write specified cam block properties
2	LS_READCAMBLOCKNODE	Read specified cam block node data
3	LS_WRITECAMBLOCKNODE	Write specified cam block node data
4	LS_GENERATECAMDATA	Create cam profile from specified cam block
5	LS_SAVECAMBLOCK	Save designated cam block data (backup)

Notice

- The following version is required to use CAM block editor and function block.
 - XGF-M32E OS version 1.40 or higher and XG-PM 3.3 or higher
- If the CAM block is modified with a Function Block and is not saved with the LS_SaveCamBlock FB, the cam block data is not backed up.

(2) Improved CAM Profile point

- Improvements have been made so that up to 100 points can be set per cam profile and cam points can be set up to 32768 points.
- When creating a cam profile, more detailed cam settings are possible than before.

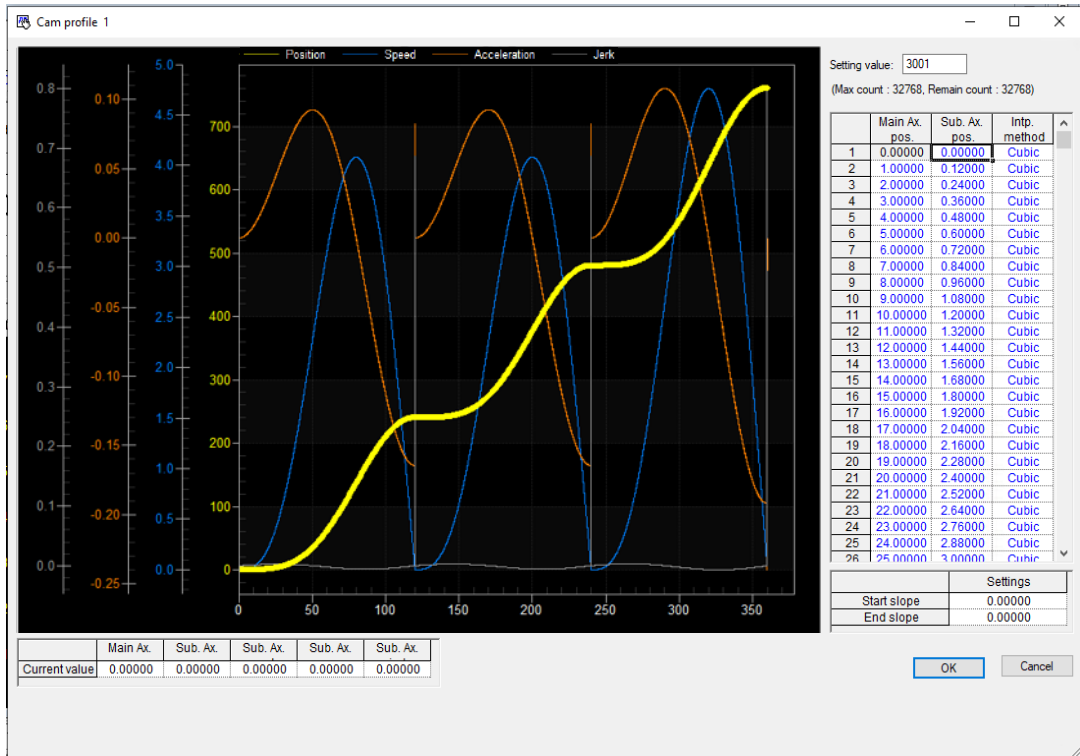

Not i ce

1. The following version is required to use the cam profile point extension function.
 - XGF-M32E OS version 1.40 or higher and XG-PM 3.3 or higher
2. Under XGF-M32E OS version 1.40, the warning is output when downloading after setting more than 100 cam profile points and only 100 point data can be written.

(3) Added XGF-PN16B Module (XGK/XGI/XGR)

- XGF-PN16B(16-axis product) is added to the network-type module.

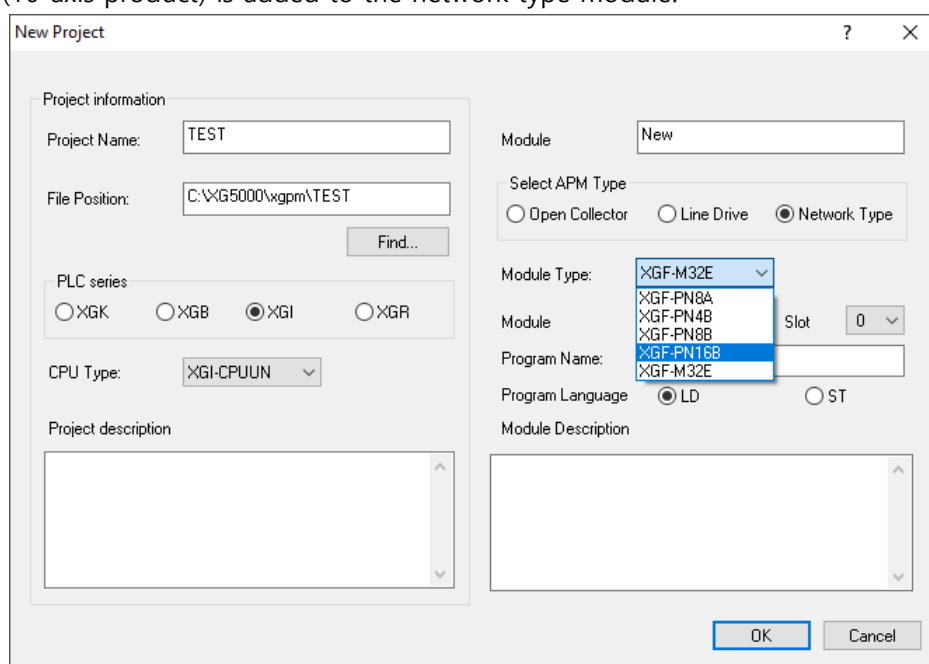
**(4) Improved read/write speed of operation data and cam data**

- Operation data and cam data read/write speed has been improved. In the existing network-type positioning product, read/write was performed on the entire data including the area not set by the user. In the improved version, data is read only by the number of steps and points set by the user. As a result, the user setup time has been significantly improved compared to the previous one.
- System view monitor speed has been improved by more than 50% compared to the previous one.
- Servo parameter read/write speed has been improved by more than 30% compared to the previous one.

Notice

1. The following version is required to apply the operation data and servo parameter read/write speed improved version.
 - XGF-PN16B 2.20 or higher and XG-PM 3.3 or higher
 - XGF-PN4B/XGF-PN8B and XBF-PN04B/XBF-PN08B will be supported later
2. In case of cam data read/write speed improvement and system view monitor speed improvement, it has been improved in XG-PM 3.3 or higher regardless of module OS version.

(5) Added function to apply to all axes of parameters

- [Apply to all axes] option has been added to detailed parameter settings for convenience when setting multiple axes.

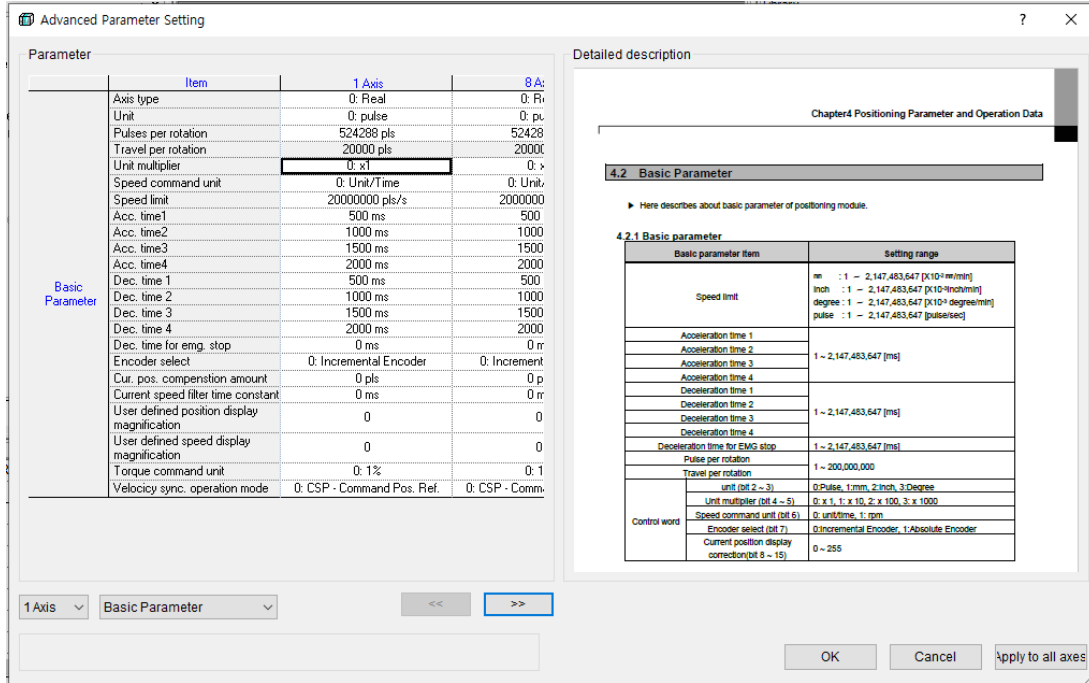

■ ReleaseNote - XG5000 V4.52.3 (Beta)

1. Improvements and additions

(1) Improved communication speed of Local Ethernet(XGK-CPUxN, XGI-CPUUN)

Program download/upload speed via local Ethernet has been improved.

2. Error Correction

(1) Fixed a problem to display the instruction help file(PDF)

The problem that the instruction help file was not displayed normally depending on the Acrobat Reader version has been fixed.

(2) Fixed a problem when entering the ESC key in the Find/Replace dialog box

The problem that the shortcut key does not work after pressing the ESC key in the Find dialog box has been fixed.

(3) Fixed the problem of saving the [Retain Area Group Setting] setting in the [Basic Parameter Setting]

The problem with saving and restoring retain group settings has been fixed.

(4) Fixed the disappearance of comments when changing PLC type

The problem that the variable/comment disappears when the PLC type is changed to XGK-CPUUN → XGK-CPUHN has been fixed.

(5) Fixed the problem of XMC EtherCAT slave configuration

The problem that EtherCAT slaves were not added to the extended EtherCAT slaves has been fixed.

(6) Fixed the problem of the parameter of XGL-PMEB DP V0

The problem of not communicating with the slave(XGL-PMEB DP V0) has been fixed.
ex) Sendix Encoder

(7) Other abnormal termination error correction

The abnormal termination problems have been fixed.

Notice

XG5000 V4.52.3 is a beta version with several functions and errors corrected in V4.52.
Please refer to the Release Note and use it only when necessary.
Otherwise, please use the official version of XG5000 V4.52.
(Additional functions may not work depending on the product O/S version.)

■ ReleaseNote - XG5000 V4.52.2 (Beta)

1. Error Correction

(1) Fixed a problem where the VAR_EXTERNAL and VAR_EXTERNAL_CONSTANT types were not displayed (IEC project)

Fixed a problem where VAR_EXTERNAL and VAR_EXTERNAL_CONSTANT types were not displayed in the variable type when adding a variable or editing a variable in the variable selection dialog box.

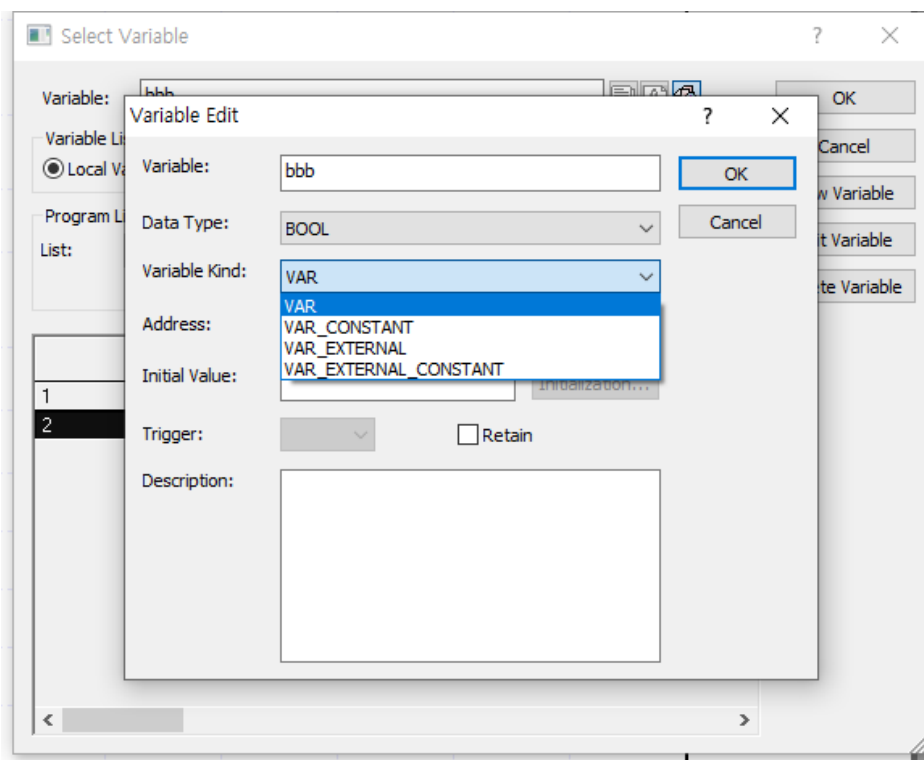

(2) Fixed [Open from PLC] problem in XGK general type and XGB project

If an R bit device (e.g., R18000.F) is used for the positive transition-sensing contact (-|P|-) and the negative transition-sensing contact (-|N|-), there is a problem that an error occurs in the logic when [Open from the PLC].

If you downloaded it with V4.52 and V4.52.1, you will need to rewrite it with V4.52.2.

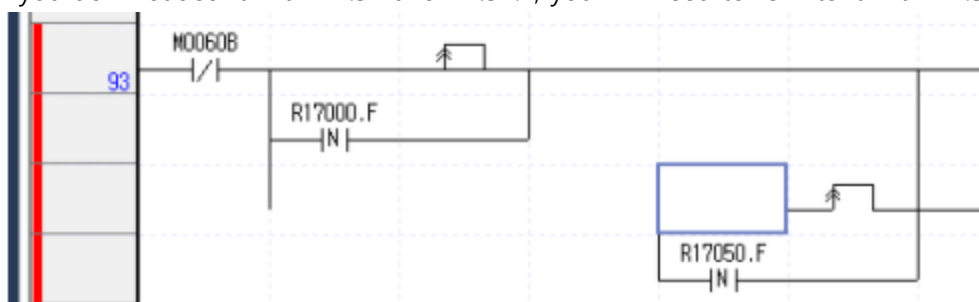

(3) Other abnormal termination error correction

Notice

XG5000 V4.52.2 is a beta version with several functions and errors corrected in V4.52.

Please refer to the Release Note and use it only when necessary.

Otherwise, please use the official version of XG5000 V4.52.

(Additional functions may not work depending on the product O/S version.)

ReleaseNote - XG5000 V4.52.1 (Beta)

1. Improvements and additions

(1) [Smart Extension] Added keep input function when a communication device error occurs

An option to set whether or not to keep the input when an error occurs during communication with the communication device has been added. In the [Communication device operation setting] window of [Smart Extension] tab, the [Keep input when a communication device error occurs] can be set. (XGL-EFMTB V8.43 or later)

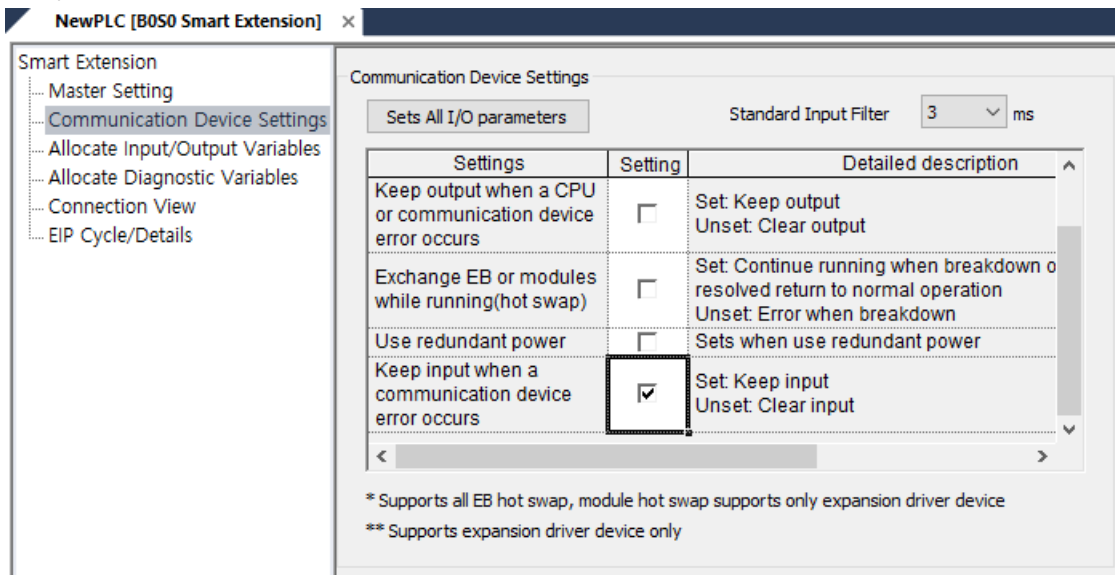

If [Enables Master Communication Device] is unset in the [Basic Parameter] window of [Set Communication Device] tab, the [Keep input when a communication device error occurs] setting can be set only for the corresponding slave.

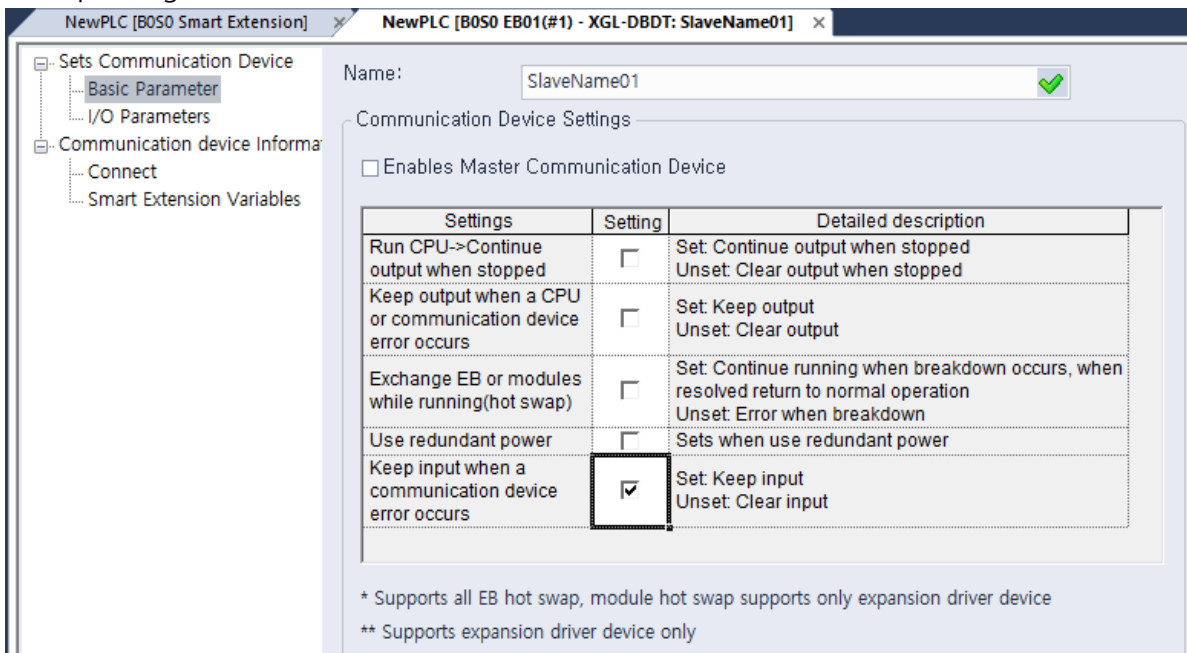

(2) Added a confirmation message when clicking the [Synchronize] button.

The following message has been added when clicking the [Synchronize] button in the [Allocate Input/Output Variables] window of the [Smart Extension].

- "When variable synchronization is executed, the smart extension variable name is changed to the variable name declared in the global variable list. The global variable is set smart extension property and restricted on variable editing. Would you like to proceed?"

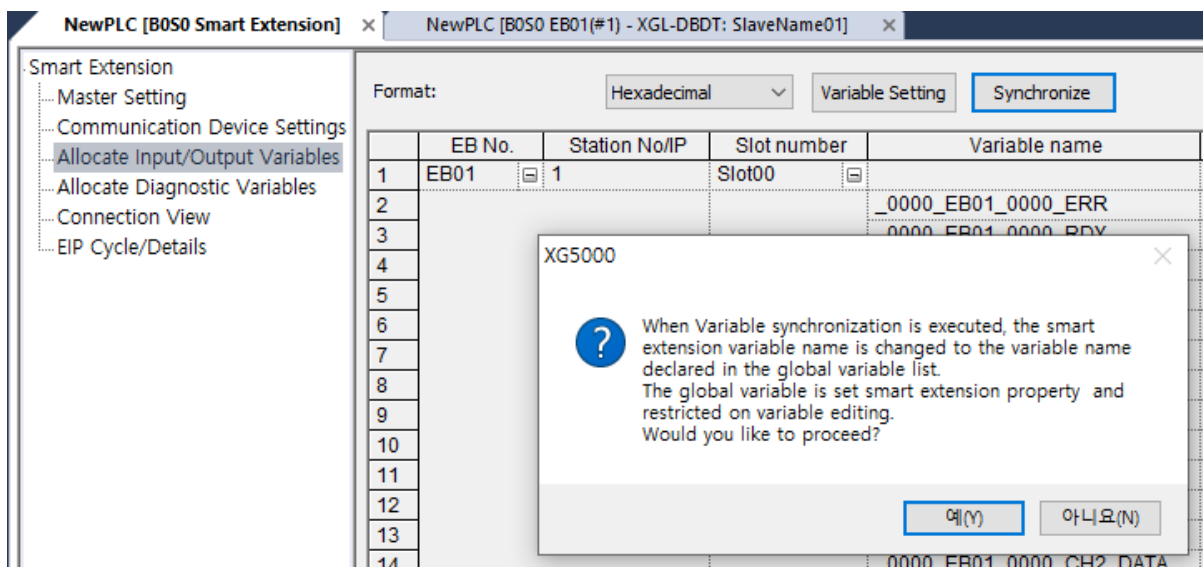

2. Error Correction

- (1) RAPIEnet auto scan image not displayed error correction
- (2) Breakpoint list/condition menu selection deactivation error correction
- (3) Correction of the error that the smart extension input/output area disappears in the multi-project
- (4) Fixed an error where warning message was not displayed when XGR M area retain was changed.
- (5) Correction of time constant compilation error in ST program
- (6) EDS parsing error correction (product name and version blank handling)
- (7) Fixed an error that does not auto-scroll when searching for direct variables
- (8) Correction of ARY output error in XEC-DxxxU/XEM-DxxxHP UDFB
- (9) EIP detailed setting parameter download data error correction
- (10) Initial value setting window Dual monitor display error correction
- (11) Correction of data size calculation error when applying only some stations in the smart extension wizard
- (12) Correction of write speed drop error during XGK multi-program run
- (13) Fixed an error in which ONE IP was released when uploading in V4.52 after setting XGR CPU ONE IP in V4.30
- (14) EtherCAT SDO parameter item read/write activation error correction
- (15) Correction of contact selection window display error after Ctrl+F is finished
- (16) Fixed port information error when operating XMC general slave [Up]/[Down]
- (17) Corrected I/O type window deactivation error in smart extension EIP service
- (18) Line Edge malfunction error correction (when undoing operation after pasting)
- (19) Correction of errors that are written during run in the state of program inconsistency (when changing PLC)
- (20) Other abnormal termination error correction

Notice

XG5000 V4.52.1 is a beta version with several functions and errors corrected in V4.52. Please refer to the Release Note and use it only when necessary. Otherwise, please use the official version of XG5000 V4.52. (Additional functions may not work depending on the product O/S version.)

■ ReleaseNote - XG5000 V4.52

1. Improvements and additions

(1) Added multi connection function (XGI-CPUUN)

Three XG5000s can be connected to the PLC CPU module at the same time through local Ethernet. Up to 4 XG5000s can use simultaneous connection to one CPU module.

The status of XG5000 currently connected to PLC can be checked.

[Steps]

1. Select [ONLINE] – [Change Mode] - [Check Connection Status]

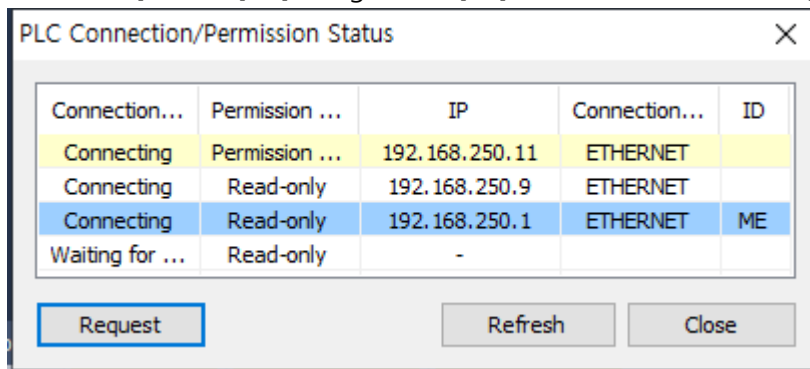

Connection Status: Connection Status, Permission Status, Connection Method are displayed.

Request: It is used when in Read-only status and when you want to request write permission.

Refresh: The connection information is updated to the latest state.

Close: Close the dialog box.

[Request and grant permission]

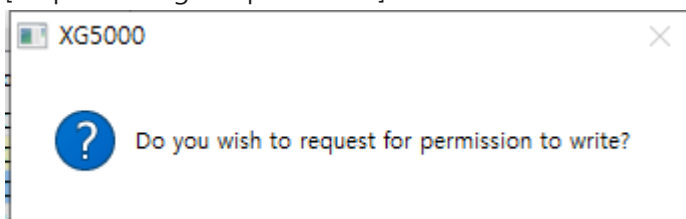

When requesting permission, XG5000 with write permission displays a confirmation message to accept or reject the permission request.

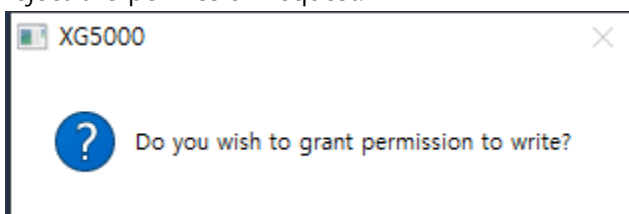

However, in the case of write and online modification status, the permission request is automatically denied.

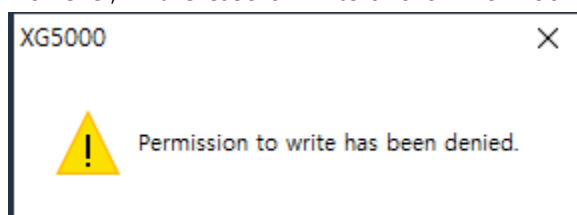

[Note]

- You can also request write permission through the menu [Online]-[Current connection status]-[Request].
- Multi connection function works only with XGI-CPUUN O/S V1.62 or higher.
- When using XG5000 V4.52 or earlier, there are restrictions on functions.

(2) Change the project information saving file

The internal files (.wstx, .vmt, .cst, .dst) created when saving the project file are integrated into one file (.stat). When opening with a new version, previously created files are deleted.

The following improvements have been made to saving project state.

- Ladder program scrolling position memory
- Variable window and local variable window information (size, column width, position, etc.)

(3) Project tree collapsing and expanding function

This is a function that allows you to easily collapse or expand sub-items in the project tree.

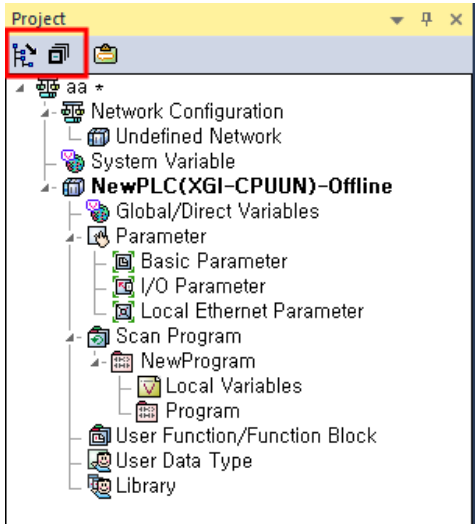

[Collapse all child item]

After selecting an item, click [Collapse all child item].

Items of level 2 or lower are folded based on the selected item. (Grandchild level)

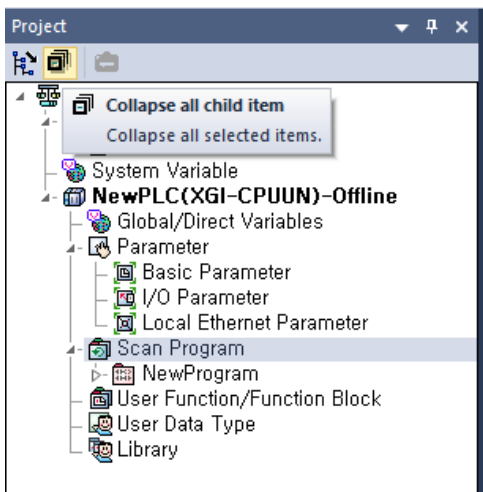

[Expand all child item]

After selecting an item, click [Expand all child item].

All items are expanded based on the selected item.

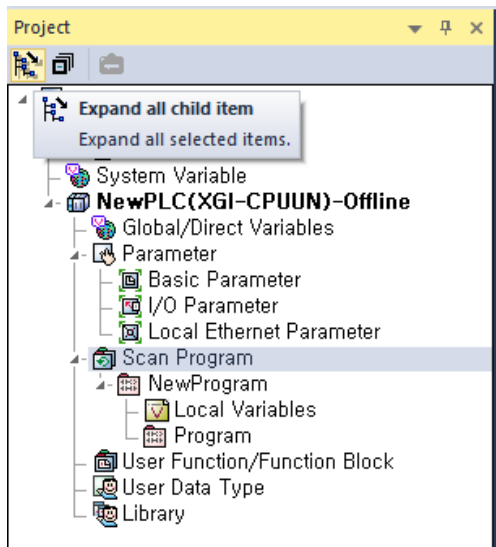

(4) Create Custom network group

This is a function to create custom groups, not by Network Type.

[Steps]

Right-click on [Network Configuration] in the project tree.
Select [Custom network] as the network type, then click the [OK] button.

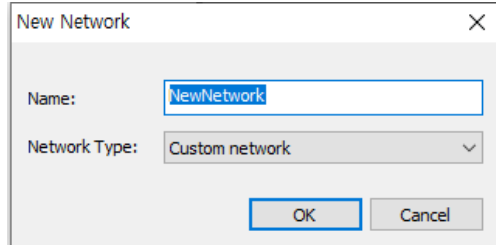

After clicking [Custom network], click [Add Item – Communication Module] to add the communication module to be added.

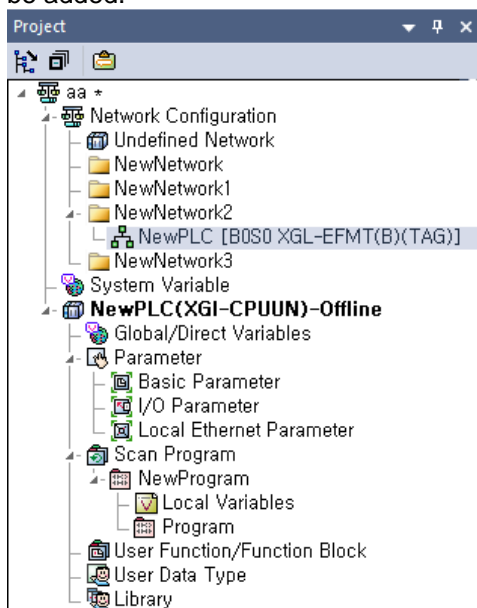

[Note]

- Nested folder structure is not supported.
- It can be moved by drag & drop.
- Project information is saved in the upload (XGI series) or comment (XGK series) area.
- When deleting a module, you can delete the communication module at once or move to the basic network.

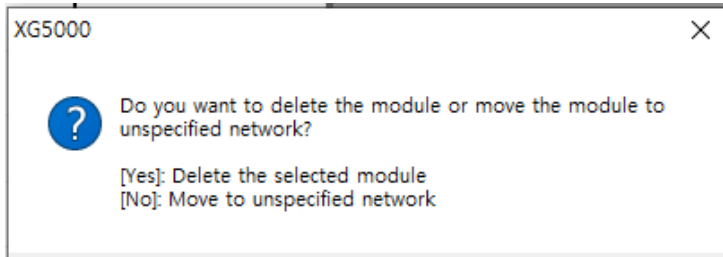

(5) Improved the function of deleting CAM Profile

It has been improved to be deleted even in online status.

(6) Improved the function of changing the direct variables

When changing a device, the [Change to the new format] function has been added, and it has been improved to change to %MX0 => %MW0.0.

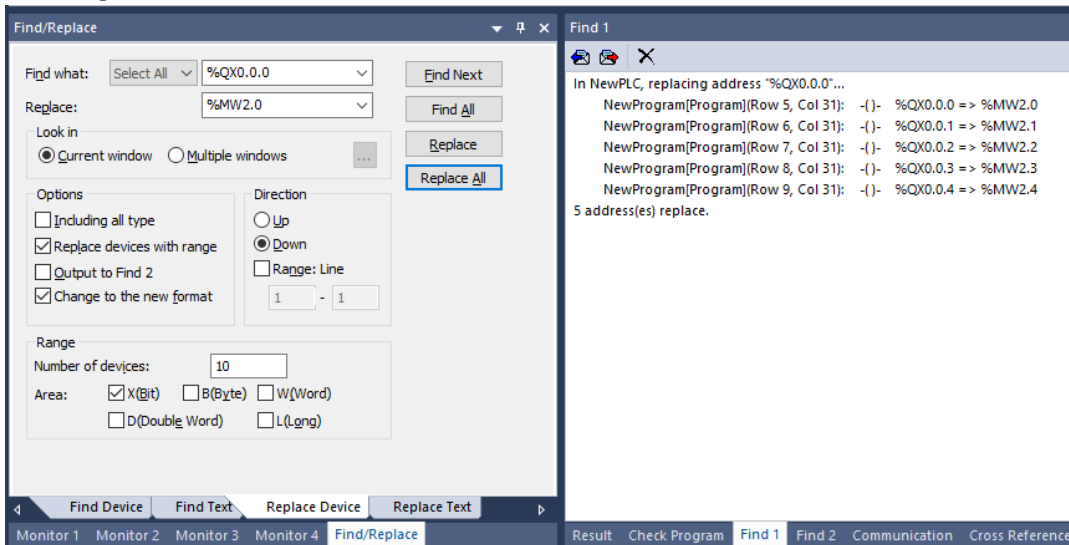

(7) Improved variables list display performance

When a variable is added or deleted, the list of global variables or local variables is maintained.

- The added variable is added to the last line.

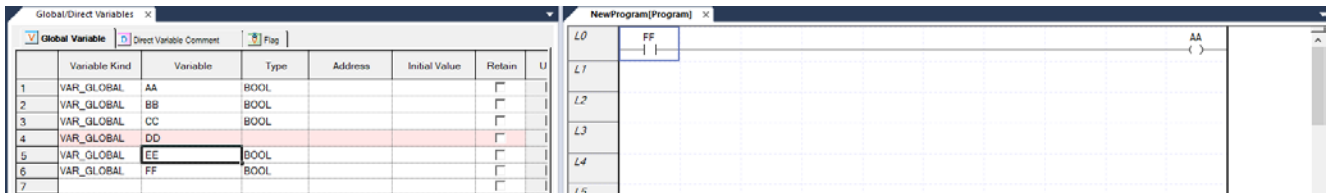

- For the deleted variable, the corresponding line is deleted.

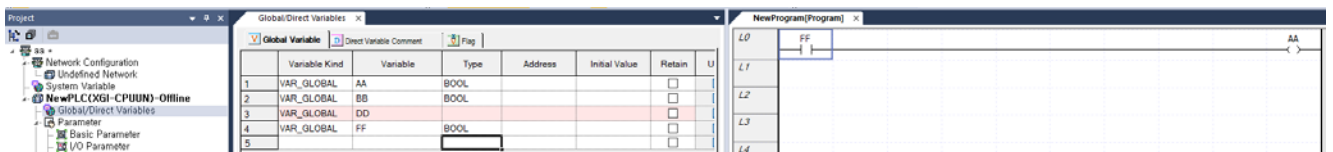
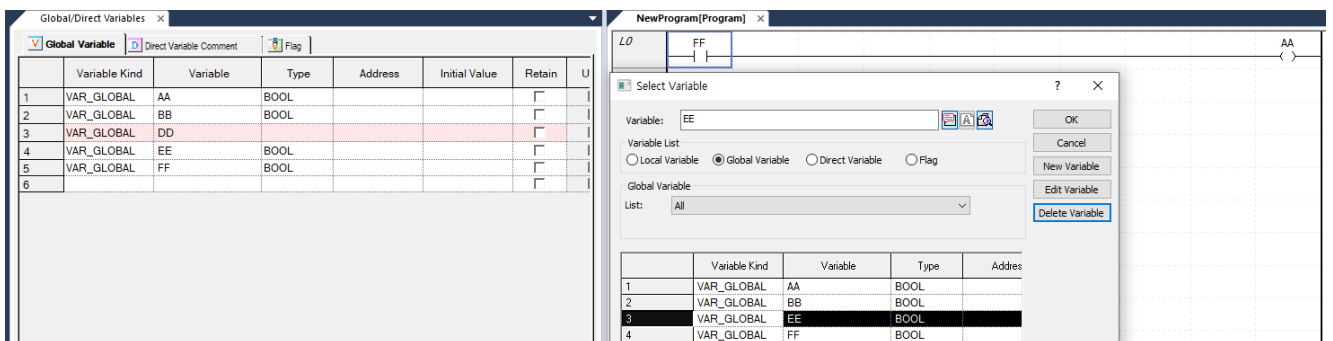
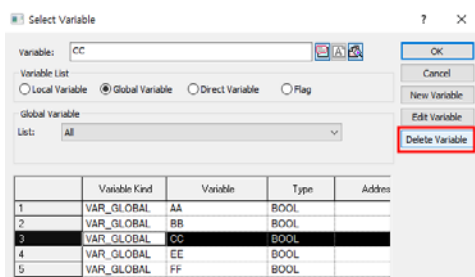

- Even when the global variable window is opened again, it is displayed in its previous state.

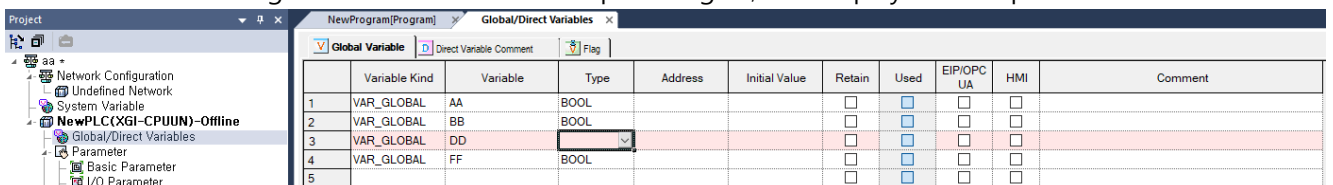

(8) Added function to remove unused variables/comment variables

A function to remove variables that are not used by local variables has been added.

[Steps]

1. Activate the global variable window
2. Click the menu [EDIT]-[Remove all unused variable/comment]-[Local Variable].

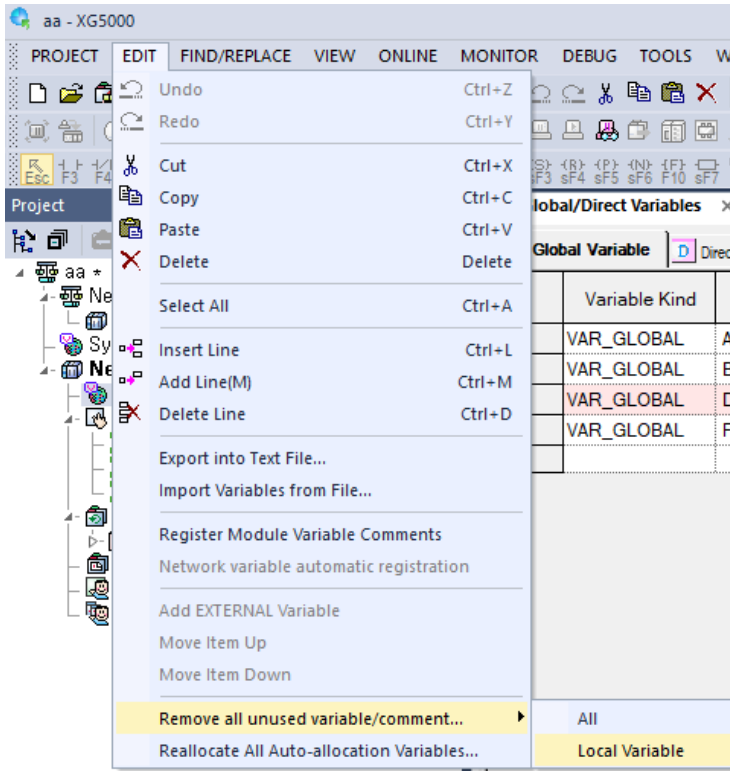

(9) Added function to move variable column header

A function to move the position of the column header in the variable window (Global variable, Local variable, User data type) has been added.

[Steps]

1. Move to the column position while clicking the column header with the mouse cursor.

- Global/Direct Variables

	Variable Kind	Variable	Type	Address	Initial Value	Retain	Used	EIP/OPC UA	HMI	Comment
1	VAR_GLOBAL	AA	BOOL	%IX0.0.0		<input type="checkbox"/>	<input type="checkbox"/>	<input type="checkbox"/>	<input type="checkbox"/>	contact1
2	VAR_GLOBAL	BB	BOOL	%QX0.1.0		<input type="checkbox"/>	<input type="checkbox"/>	<input type="checkbox"/>	<input type="checkbox"/>	output1
3	VAR_GLOBAL	FF	BOOL	%IX0.0.1		<input type="checkbox"/>	<input type="checkbox"/>	<input type="checkbox"/>	<input type="checkbox"/>	contact2
4						<input type="checkbox"/>	<input type="checkbox"/>	<input type="checkbox"/>	<input type="checkbox"/>	

	Variable	Variable Kind	Type	Address	Initial Value	Retain	Used	EIP/OPC UA	HMI	Comment
1	AA	VAR_GLOBAL	BOOL	%IX0.0.0		<input type="checkbox"/>	<input type="checkbox"/>	<input type="checkbox"/>	<input type="checkbox"/>	contact1
2	BB	VAR_GLOBAL	BOOL	%QX0.1.0		<input type="checkbox"/>	<input type="checkbox"/>	<input type="checkbox"/>	<input type="checkbox"/>	output1
3	FF	VAR_GLOBAL	BOOL	%IX0.0.1		<input type="checkbox"/>	<input type="checkbox"/>	<input type="checkbox"/>	<input type="checkbox"/>	contact2
4						<input type="checkbox"/>	<input type="checkbox"/>	<input type="checkbox"/>	<input type="checkbox"/>	

Global/Direct Variables										
Global Variable										
	Variable	Comment	Variable Kind	Type	Address	Initial Value	Retain	Used	EIP/OPC UA	HMI
1	AA	contact1	VAR_GLOBAL	BOOL	%IX0.0.0		<input type="checkbox"/>	<input type="checkbox"/>	<input type="checkbox"/>	<input type="checkbox"/>
2	BB	output1	VAR_GLOBAL	BOOL	%QX0.1.0		<input type="checkbox"/>	<input type="checkbox"/>	<input type="checkbox"/>	<input type="checkbox"/>
3	FF	contact2	VAR_GLOBAL	BOOL	%IX0.0.1		<input type="checkbox"/>	<input type="checkbox"/>	<input type="checkbox"/>	<input type="checkbox"/>
4							<input type="checkbox"/>	<input type="checkbox"/>	<input type="checkbox"/>	<input type="checkbox"/>

- Local Variables

Global/Direct Variables										
NewProgram[Local Variables]										
	Variable	Comment	Variable Kind	Type	Address	Initial Value	Retain	Used	EIP/OPC UA	HMI
1	AA	contact1	VAR_EXTERNAL	BOOL	%IX0.0.0		<input type="checkbox"/>	<input checked="" type="checkbox"/>	<input type="checkbox"/>	<input type="checkbox"/>
2	FF	contact2	VAR_EXTERNAL	BOOL	%IX0.0.1		<input type="checkbox"/>	<input checked="" type="checkbox"/>	<input type="checkbox"/>	<input type="checkbox"/>
3	BB	output1	VAR_EXTERNAL	BOOL	%QX0.1.0		<input type="checkbox"/>	<input type="checkbox"/>	<input type="checkbox"/>	<input type="checkbox"/>

- User Data Type

Global/Direct Variables						
NewProgram[Local Variables]						
aa						
	Variable	Type	Address	Initial Value	Retain	Comment
1	aa	BOOL	0.0		<input type="checkbox"/>	BOOL Type
2	bb	WORD	2.0		<input type="checkbox"/>	WORD Type
3					<input type="checkbox"/>	

Global/Direct Variables						
NewProgram[Local Variables]						
aa						
	Variable	Comment	Type	Address	Initial Value	Retain
1	aa	BOOL Type	BOOL	0.0		<input type="checkbox"/>
2	bb	WORD Type	WORD	2.0		<input type="checkbox"/>
3						<input type="checkbox"/>

[Note]

- When copying from the variable window, it is copied in the current view.
- If the column header order is different, a validation error may occur.

(10) Added User data type validation

A function to check the maximum number of members of the user data type has been added. If the number of members exceeds 1,023, it is detected as an error. (Even if ARRAY or other user data type is used for the user data type, it is counted as one)

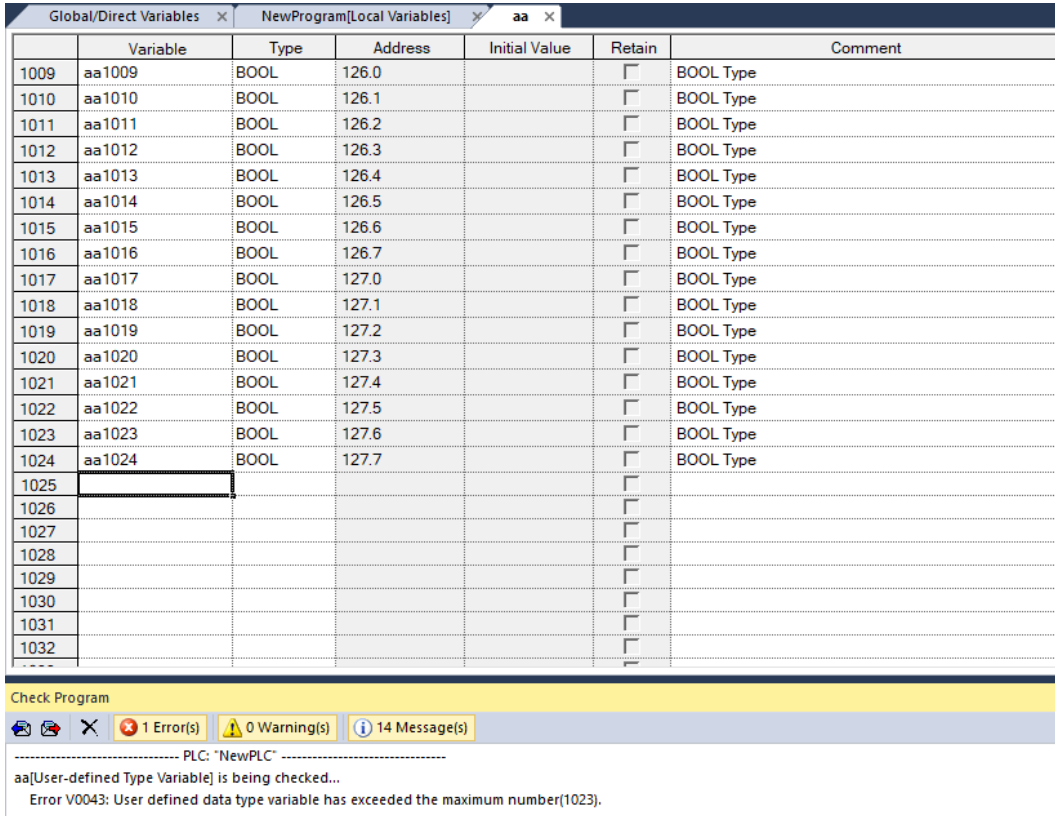



(11) Improved IEC project variable input/registration function

- Improvements have been made to keep the variable name being entered even if the variable type is selected.
- The auto-complete function has been turned into an option.
- The option has been improved to operate as an icon.

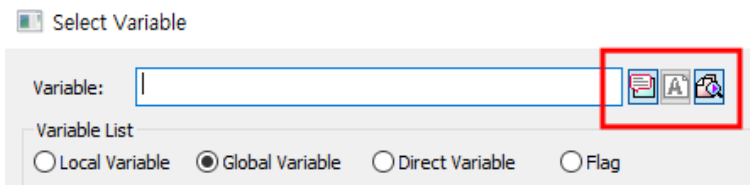
[Description]



- Add direct variable comment(): Creates Direct Variable Comment window when registering a variable.
- Auto translate to English(): Convert the default language to English when creating a new variable on the New Variable Window.
- Auto complete variable name(): Enable auto completion of variable type and name.

(12) Improved Function block instance selection(XMC)

When registering instance type variables, the Function Block selection method has been improved.

[Before improvement]

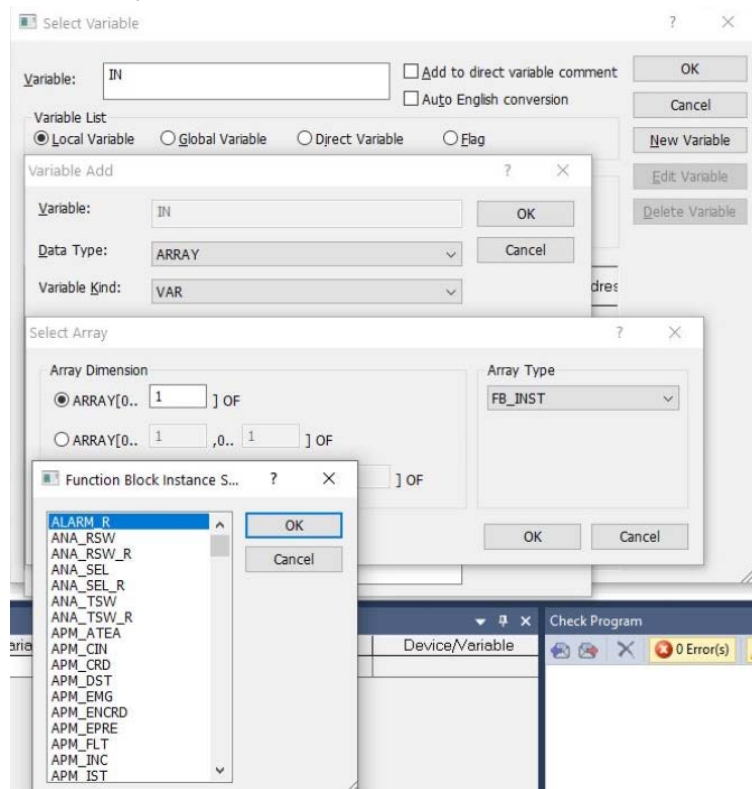

[After improvement]

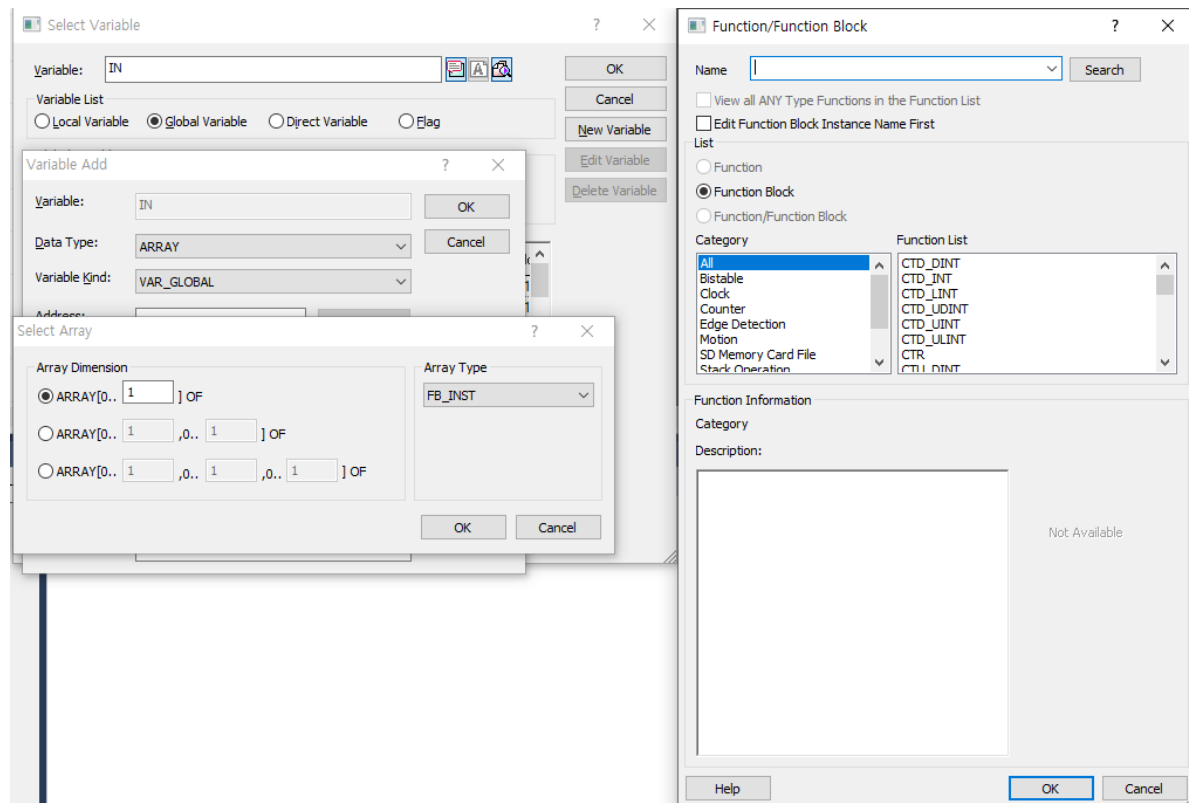

(13) Improved Device comments (XGK automatic allocation)

In the Add Device Comment dialog box, the cursor is positioned on the comment item.

(14) Improved automatic registration of module variables

When [EDIT]-[Register Module Variable Comments], variables related to smart expansion are not added. Smart expansion variables can be registered in the following procedure.

[Steps]

1. [Smart Extension] - [Allocate Diagnostic Variables] - [Variable Setting]

The variables previously declared in the [Register Special Module Variables] dialog box have been improved to be displayed on the screen. The default value varies according to the variable's registration and editing status.

- Unchanged or edited variable-Clear check box
- Added variable-check box selection

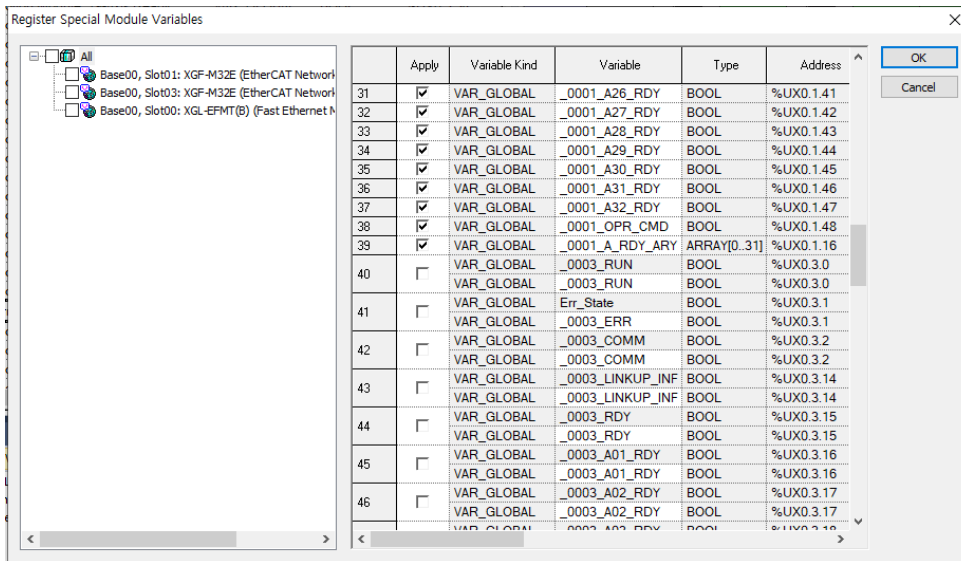

- 예) _0003_RUN: Unchanged variable
 Err_state: Edited variable
 _0001_A32_RDY: Added variable

(15) Added LD option

(a) Invalid variable color

It can be used to identify the declared and non-declared variables in the LD program.

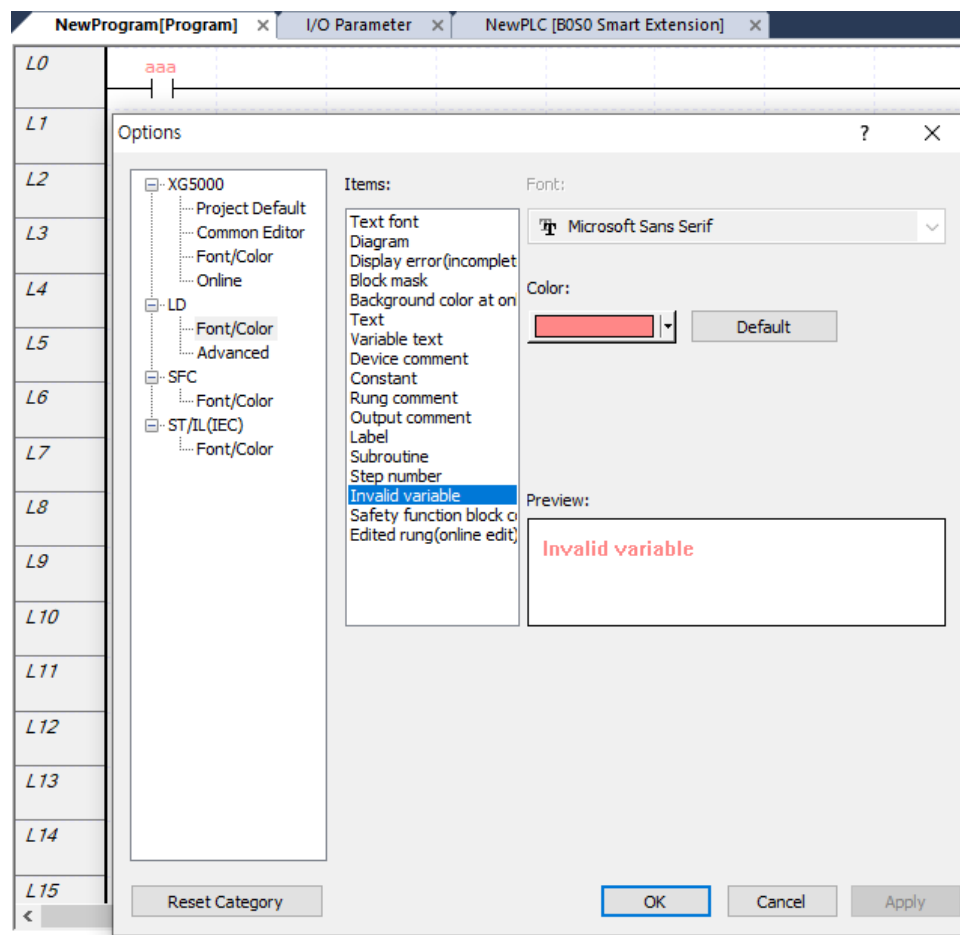

- Include variables when pasting

When pasting a ladder program, set whether or not to register the variable list. The default value is 'Paste with variable'.

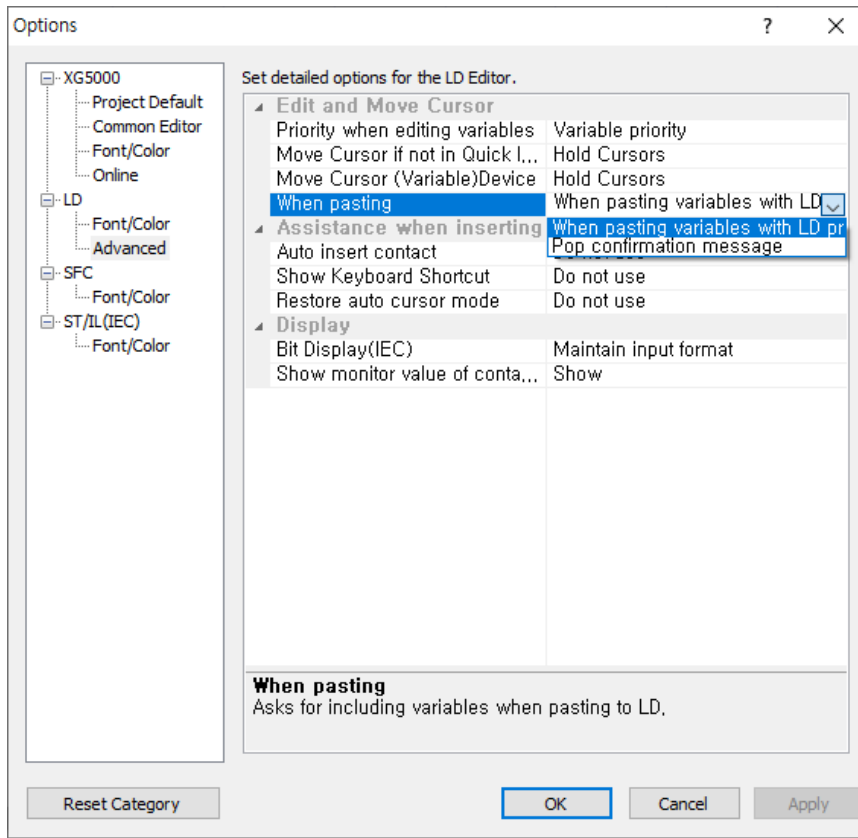

(b) Added Auto Insert contact option

You can use the function to insert the contact by using the Enter key.

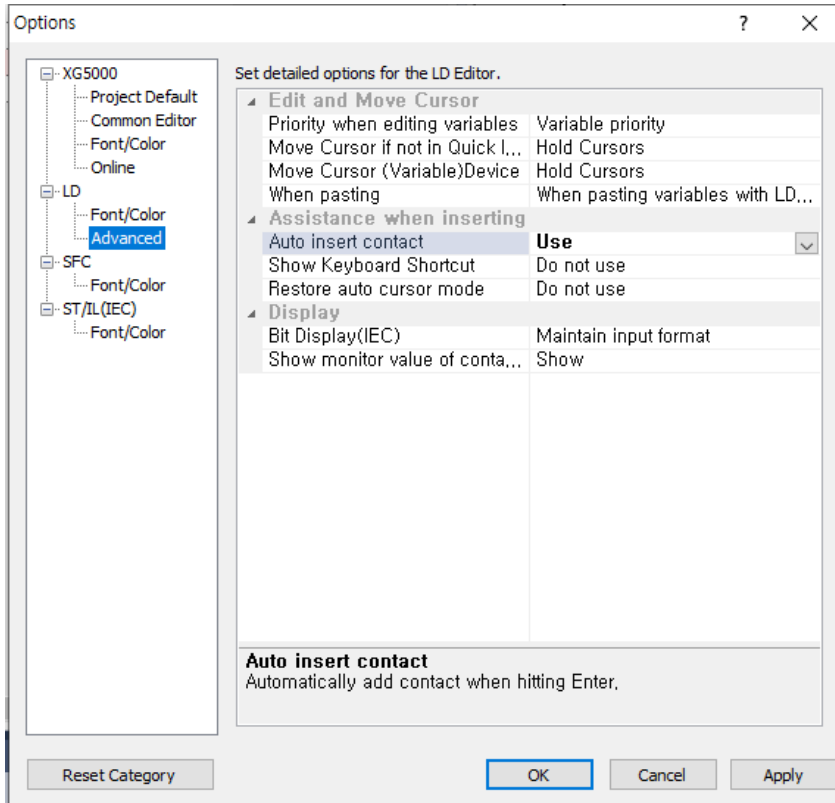

When entering the Enter key in the LD program, a contact is added at the cursor position.

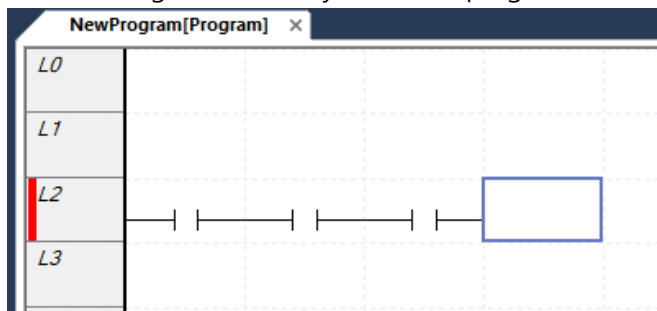

(c) Show Keyboard Shortcut

Added option to keep last selected tool in LD editing tool.

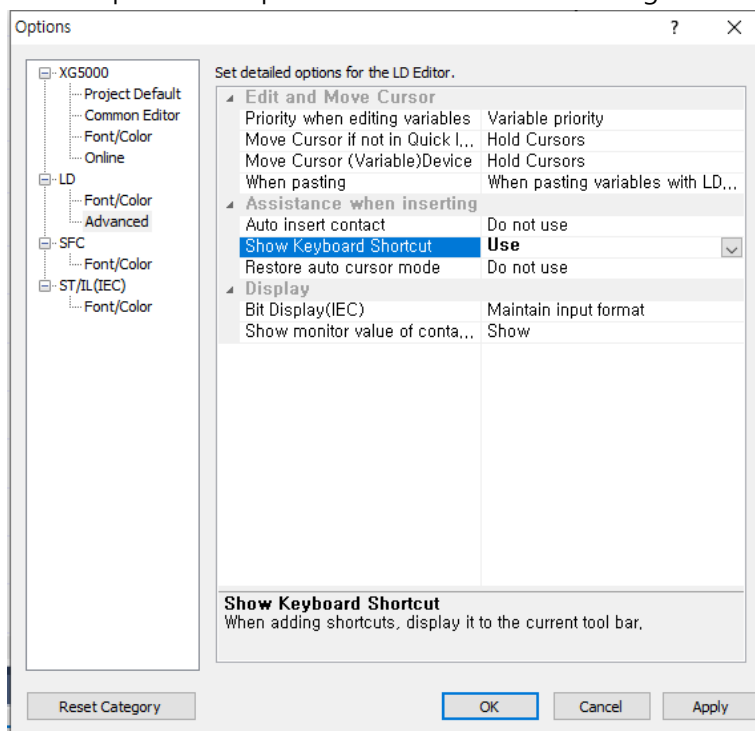

If you enter a shortcut key in the LD program, the item corresponding to the shortcut key is added to the LD program, and the tool bar selection status is maintained.

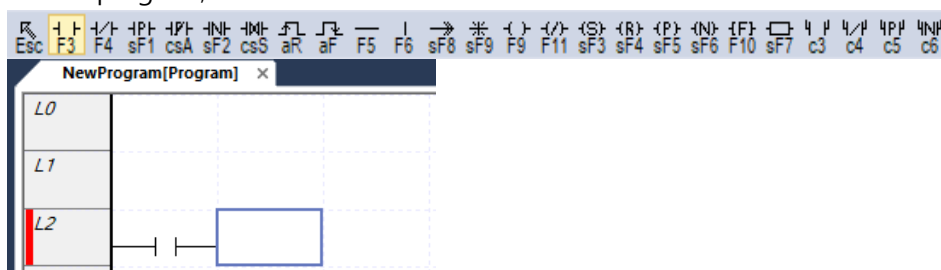

By hitting Enter, you can enter the last tool selected.

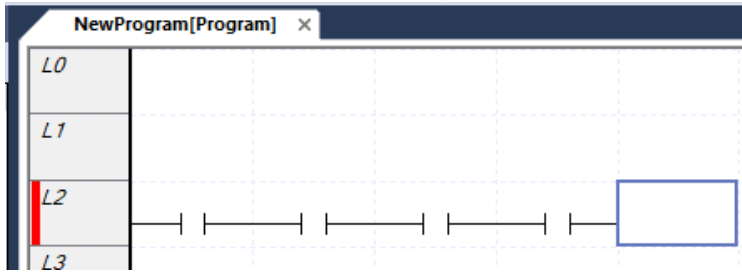

(d) Restore auto cursor mode

When editing LD program with a mouse, you can use the function to restore to cursor mode again.

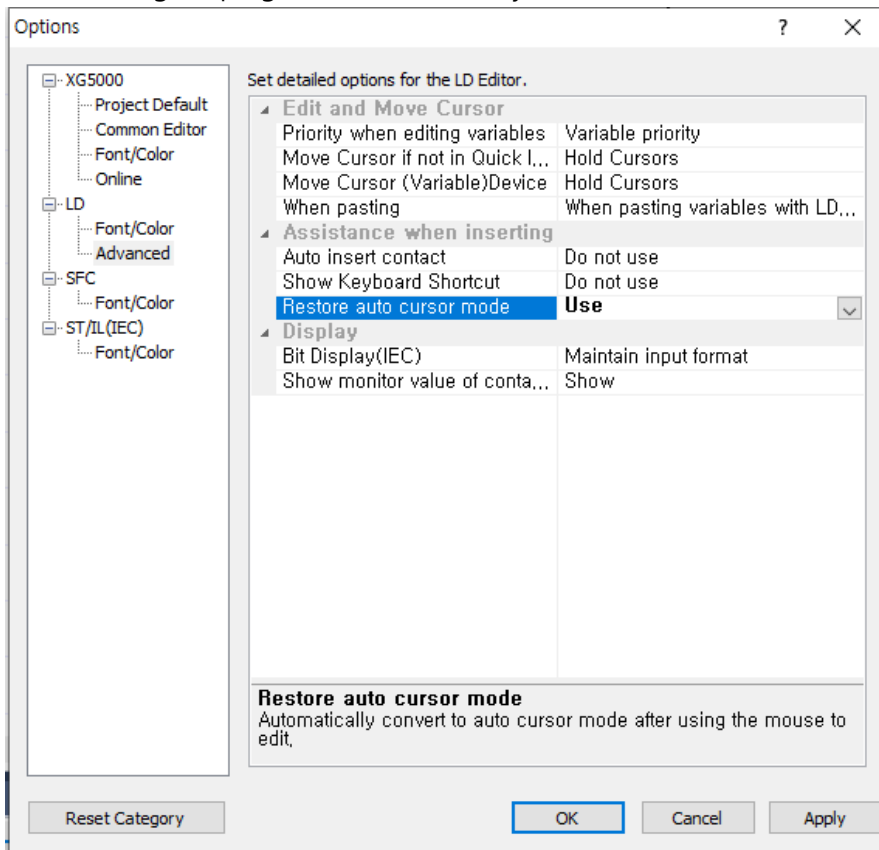

After selecting an item from the LD tool toolbar,

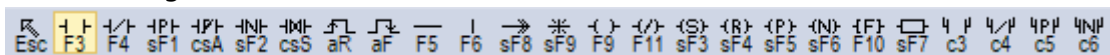

Click the desired position in the LD program to add the selected item in the tool bar.

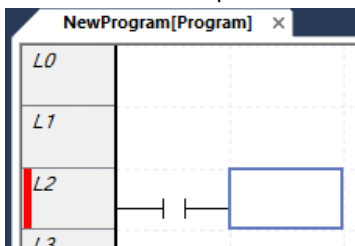

Once the addition is complete, the toolbar is restored to cursor mode.

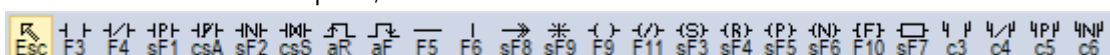

(e) Bit Display(IEC)

Added option to display bits in IEC projects. The input format can be maintained or displayed as an offset based on BOOL, BYTE, WORD, DWORD and LWORD. However, copy/paste works in the input format.

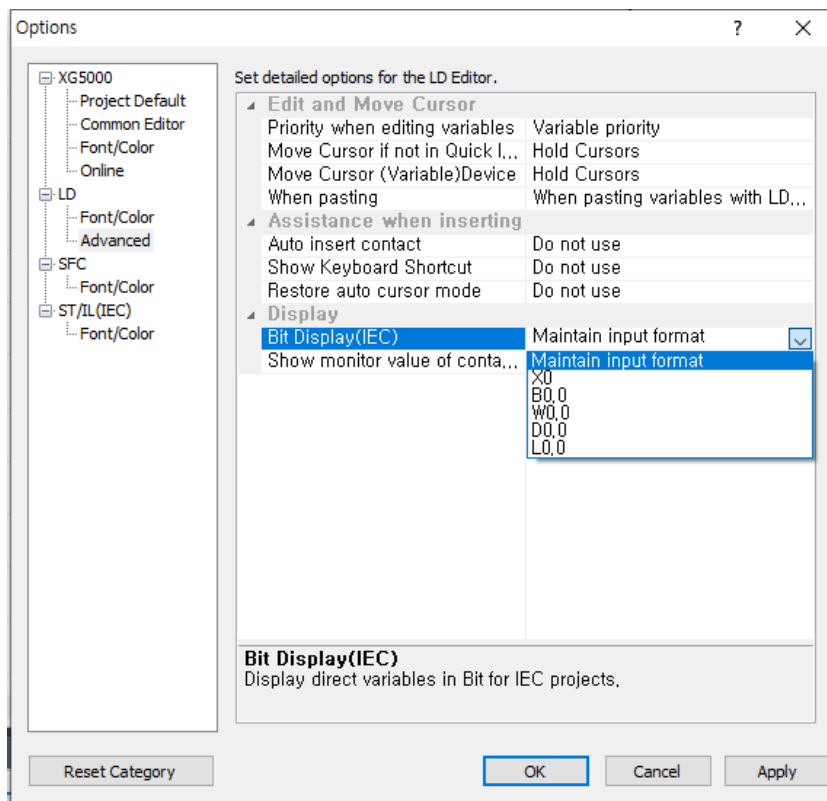
**(16) Use of declared variable when replacing string**

When replacing a string, when changing a global variable to an already declared global variable, it has been modified to be automatically registered.

(17) Inequality sign display for comparison function

The comparison function has been improved to be displayed with an inequality sign.

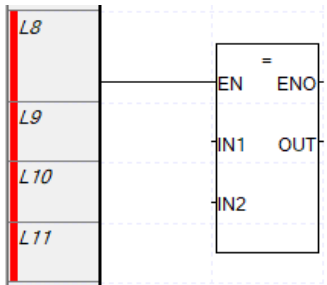
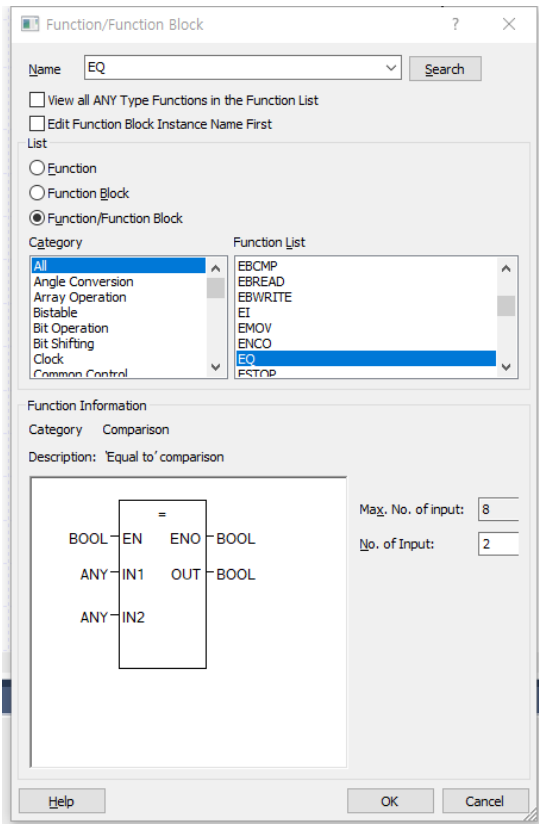

However, when find/replace a string, It must be entered as EQ.

(18) Improved contact/coil search function

The existing [Find Contact/Coil] function has been subdivided into [Find Next Contact] and [Find Next Coil]. In addition, the problem that the value of 'What to find' is changed after finding the contact/coil has been improved.

[Find Next Contact], [Find Next Coil] operations are as follows.

Item	Description	Action
Initial Shortcut Key	Find Next Contact	Ctrl + Shift + D
	Find Next Coil	Ctrl + Shift + F
Find Item	Common	LD program excluding library (excluding local variable window)
	Direct Variable(Device)	Multiple windows(Same as Find Device)
	Variable(Auto Allocate)	Current window(Same as Find String)
	Variable(Address)	Multiple windows(Same as Find Device)
After selecting a contact	When executing Find Next Contact	Go to the next same contact
	When executing Find Next Coil	Go to the next same coil
After selecting a coil	When executing Find Next Contact	Find the contact of the coil
	When executing Find Next Coil	Go to the next duplicate coil

(19) Improved Used Device

The input/output variables and diagnostic variable areas used in smart expansion have been improved to be displayed on the Used Device.

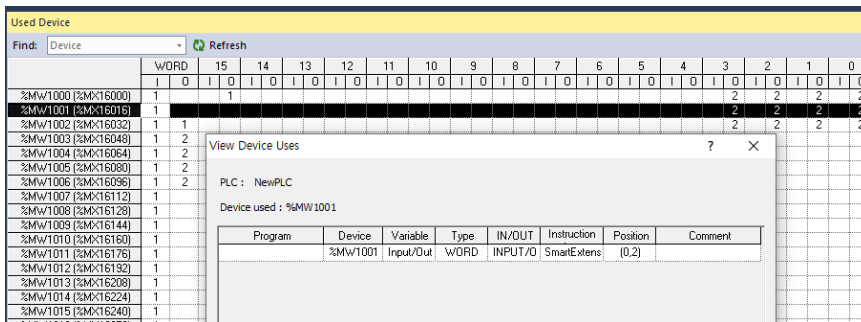
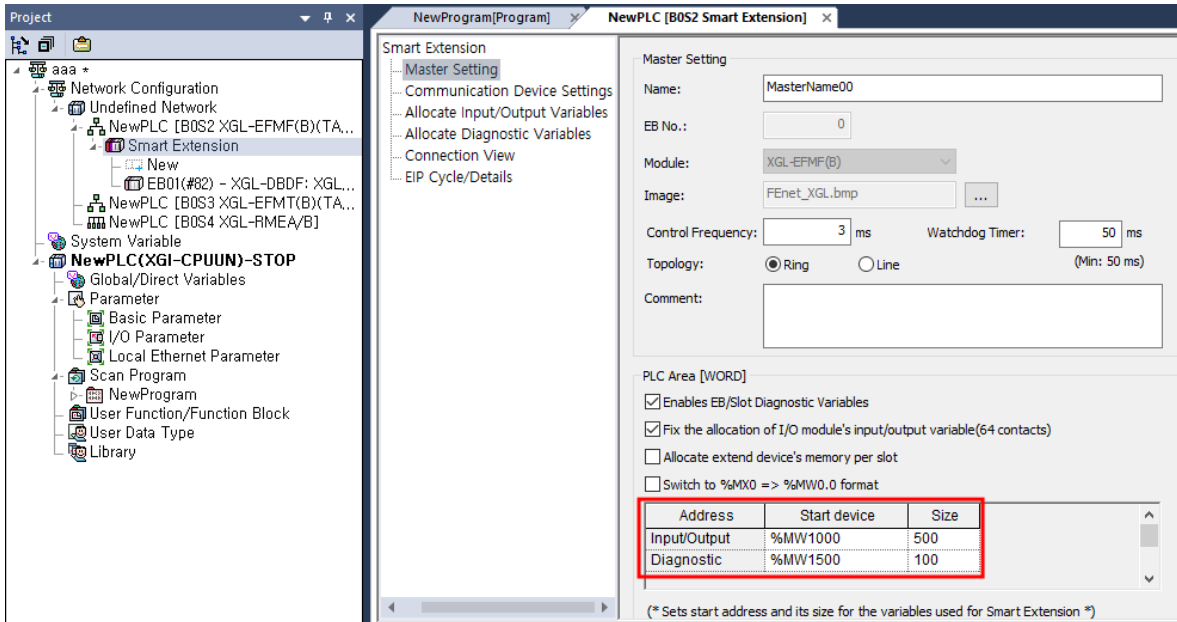

(20) Added drive models when setting P2P blockP2P

Drive latest models (M100, G100, L100) have been added.

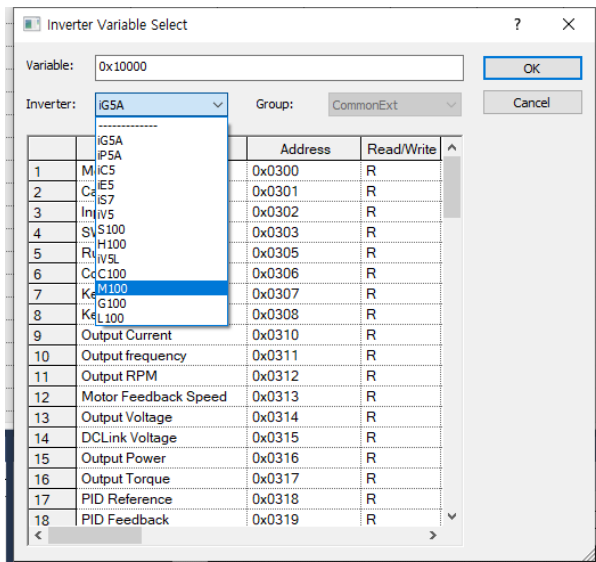

(21) Added the function [Limit auto negotiation speed to 100Mbps] in XGL-EFMxB

[Steps]

1. Click the FEnet module in the project tree.
2. After selecting [Advanced] tap, check [Limit auto negotiation speed to 100Mbps].

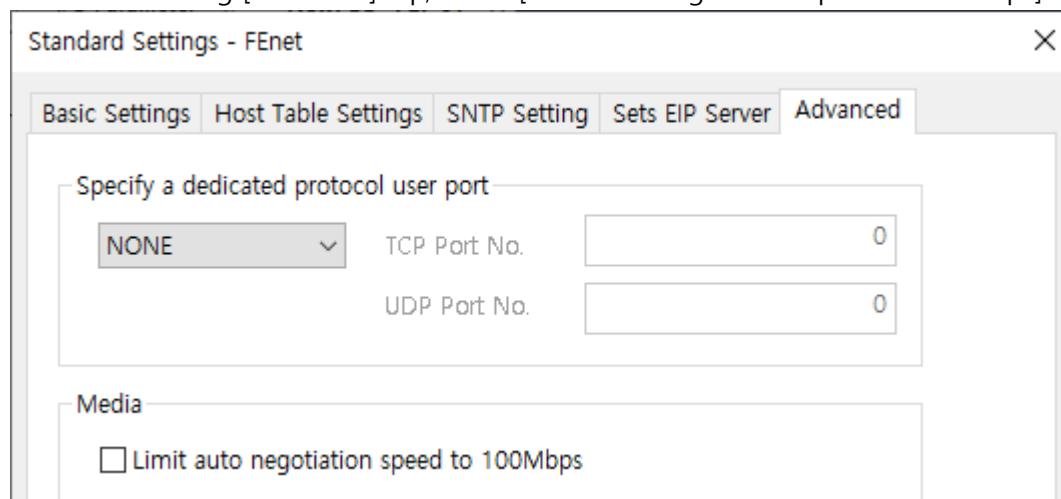

[Note]

[Limit auto negotiation speed to 100Mbps]

When using a 4-wire cable, it is used when the speed is not negotiated at 1 Gbps. For details on 100Mbps auto-negotiation speed limit, refer to the communication module manual.

(22) Smart extension station number display

It has been improved so that you can check the station number or IP address (Ethernet IP) for the EB of the smart extension in the project tree. The display format is EB number (# station number) or EB number (#IP address).

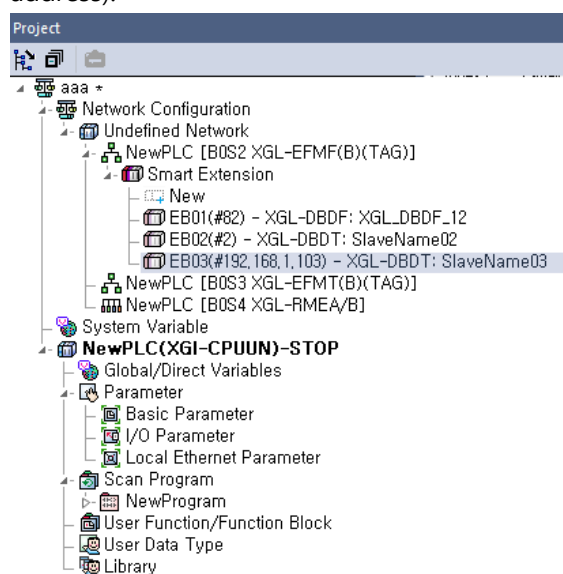

(23) Display slot number in system diagnosis window

The slot number of the module (communication, special, IO, etc.) excluding power and CPU can be checked.

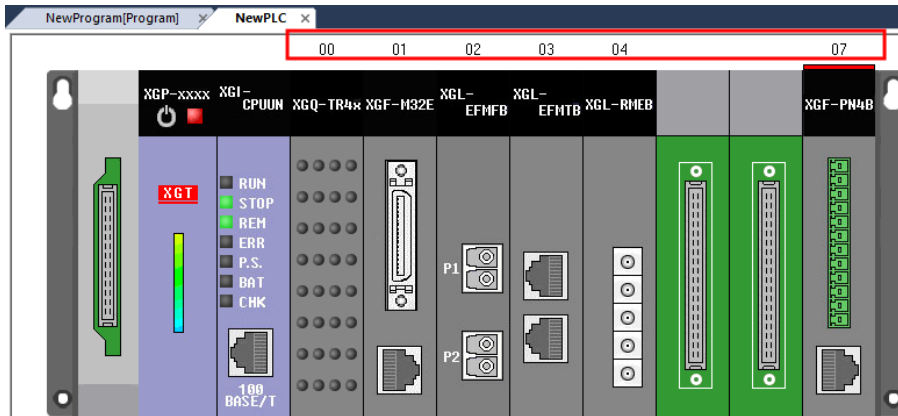

(24) Improved the function [Import Device from File] in Device Monitoring

The operation of opening device monitor file created in different types of PLC has been improved.

Before improvement: All device memories are initialized to 0.

After improvement: Data values are held for as much as a valid memory size. 유효한 메모리 크기만큼 데이터 값이 유지됩니다.

(25) Improved current consumption calculation

It has been improved to calculate the current consumption according to the detailed type of the module such as XGL-EFMx(B).

The estimated current consumption per base can be checked by pressing the [Current Consumption] button in the I/O parameter.

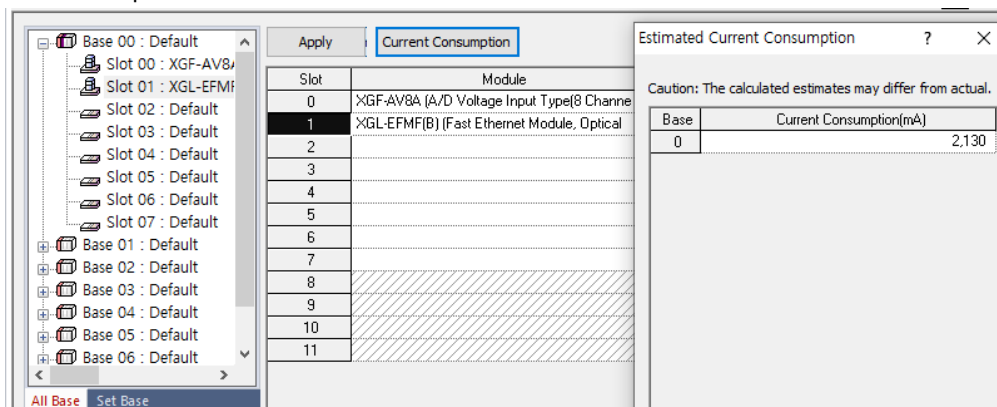

(26) Improved address calculator function

An issue that caused the cursor to move to the back when editing an intermediate value in the Address Calculator input window has been improved. Corrected so that the caret does not move even when editing.

(27) Added 2 types of XMC for moving magnet



A new XMC model has been added for moving magnet applications.

[Steps]

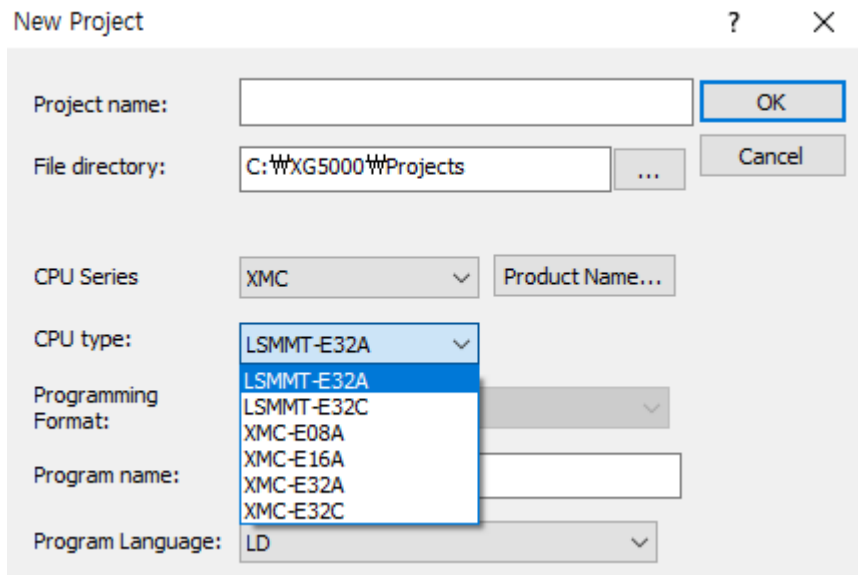
1. In the new project setting dialog box, select CPU series as XMC.



(28) Added New IEC command

- Added Closed Positive/Negative contact ( )
- ARY_SCH2 – Searching for data in an array

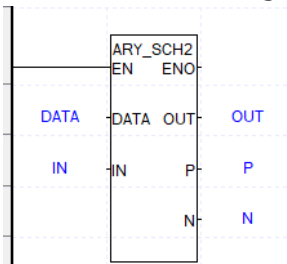

- ANY_MOVE, ANY_MOVE2 – Copy data

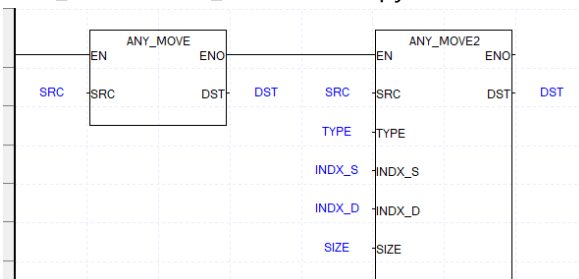

- GROUP_MOVE32, GROUP_FILL32 – 32-bit index extension

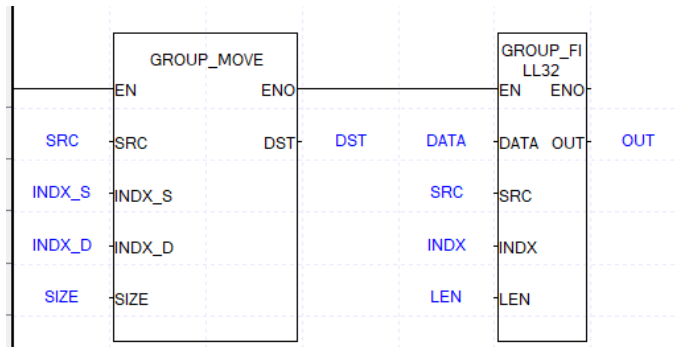

Please refer to the help for how to use the added command.

2. Error Correction

(1) Correction of navigation error when operation error occurs (XGK Auto Allocation)

Fixed a problem where the operation error occurrence location could not be found to the error location when a UDF or UDFB was included.

(2) Correction of basic network deletion error

Fixed an issue where the basic network was deleted

(3) Latch area setting error in basic parameter dialog box

An abnormal error occurred when entering a value outside the range of the latch area has been fixed.

(4) Correction of duplicate error of library function/function block and user function/function block

When pasting a user function/function block, the problem of not being able to check the duplication with the function/function block in the library has been fixed. Duplicate names are appended with "_copy".

(5) Corrected an error where the description was not changed when the device was changed (XGK Auto Allocation)

Fixed a problem in which the device description was not changed when the device was replaced in the XGK Auto-Allocation project.

(6) High speed link, P2P parameter deletion error correction

Fixed a problem where XG5000 was abnormally terminated when selecting multiple (2 or more) items from the project tree and deleting them.

(7) Correction of parameter download error in Pnet - nConfigurator

Fixed a problem where parameters for specific slaves were not downloaded normally due to GSD analysis error.

(8) Fixed STRING_TO_*** direct variable input error

When entering a DWORD type device, the problem that the input error was displayed according to the address value has been fixed.

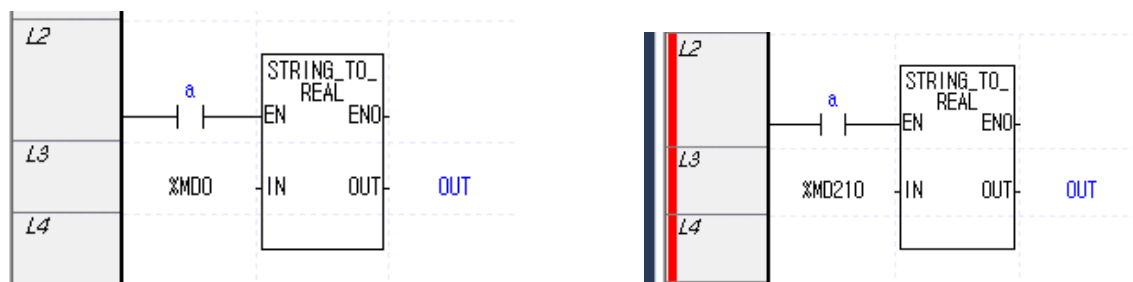

(9) Fixed an error in applying shortcut keys after [TOOLS] - [Setting File] – [Import]

Fixed a problem where the shortcut key was not reflected immediately after loading the Setting File.

(10) Abnormal termination error correction

Using the problem report reported by the XG5000 user, an abnormal termination problem has been corrected.

3. XG-PM

(1) XGF-M32E Module axis-slave connection function added

- Added a function for the user to directly control through PID control, etc. by connecting the servo drive as an EtherCAT slave without allocating it as an axis.
 - 1) Added a setting that allows direct control of the servo drive without assigning it to an axis. One of the following can be selected in the [Connect Axis] dialog box according to the user's application.
 - a. Disable: Slave and axis not connected (direct control)
 - b. Virtual axis: Used as a virtual axis (controls a virtual axis without a physical device connected)
 - c. Slave 1~32: Connect the slave and axis (control through axis)

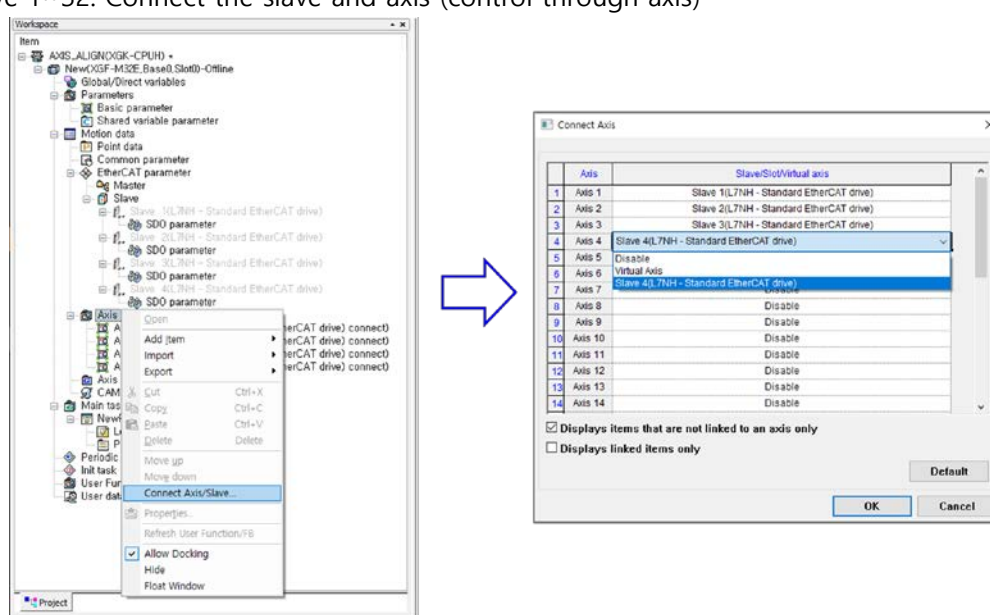

Note

XGF-M32E OS version 1.40 or higher is required to use the axis slave connection function.

- 2) The virtual axis setting range has been extended to the existing real axis in addition to the dedicated virtual axis only. (Virtual axes can be set for 1 to 32 axes in addition to 4 axes (37 to 40 axes) for virtual axes.)
 - a. Dedicated virtual axis setting
 - Like the existing virtual axis range, it is set in the 37~40 axis.

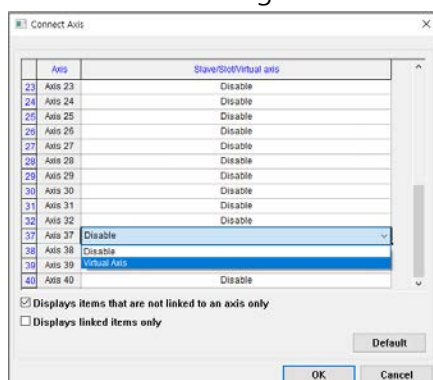

b. Virtual axis range extension

- Virtual axis can be set even in the range of real axis (Axis 1 to 32).

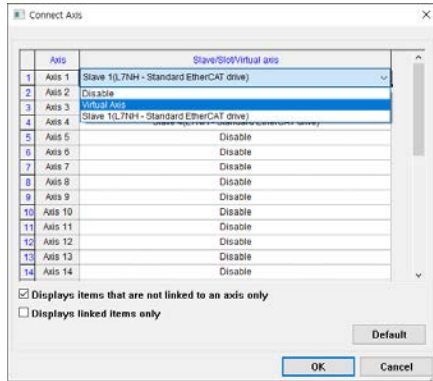

Note

As the virtual axis setting is provided through the [Connect Axis/Slave] function, the existing [Add Item]-[Slave]-[Virtual Axis] addition function has been deleted.

3) The maximum number of EtherCAT I/O slave connections has been extended from the existing 4 slaves to a maximum of 36 slaves.

a. The [Autoconnect] feature provides options for existing users as follows.

- EtherCAT I/O is assigned to slaves 33~36 when checking the assignment option to EtherCAT I/O slaves 33~36.

- If the EtherCAT I/O is more than 4 slaves, the operation must be performed after releasing the option below.

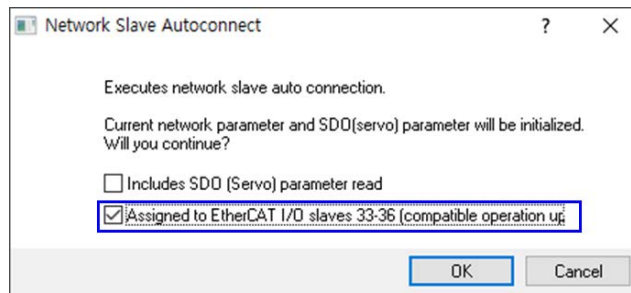

(2) Data trace result data saving/reading function added

- For the convenience of user analysis, a function to read the result data collected as a trace has been added after saving it.

1) Save trace data

- a. In addition to the existing trace setting file (filename extension .ntr) file, it is saved as a trace data file (filename extension .ntd) file.
- b. After completing the trace, the current trace data is displayed on the screen. Then execute the [File]-[Save] or [File]-[Save As] menu. Trace data is saved when saving after setting a trace data file (*.ntd) in the file format.

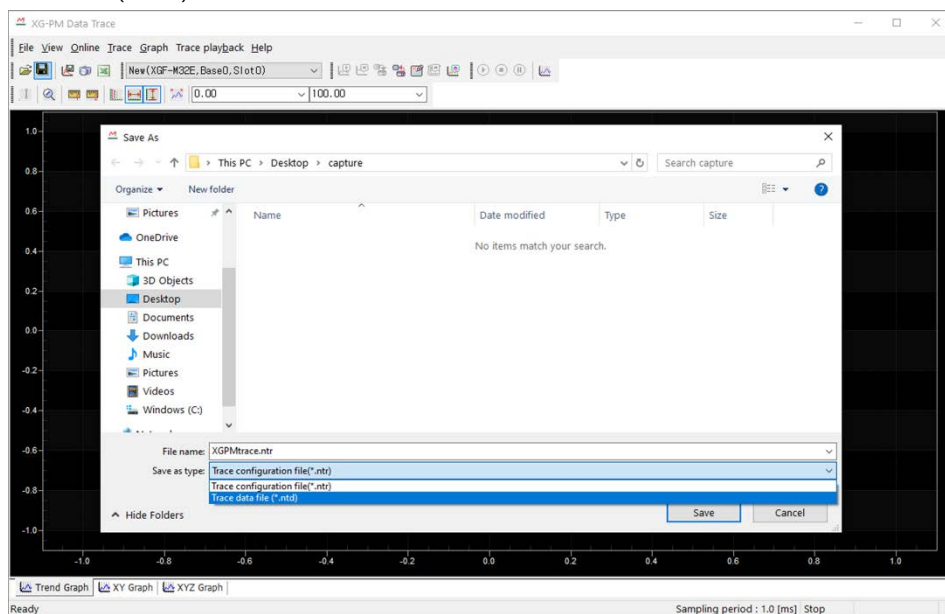

2) Open trace data

- a. Load the saved trace data file (*.ntd).

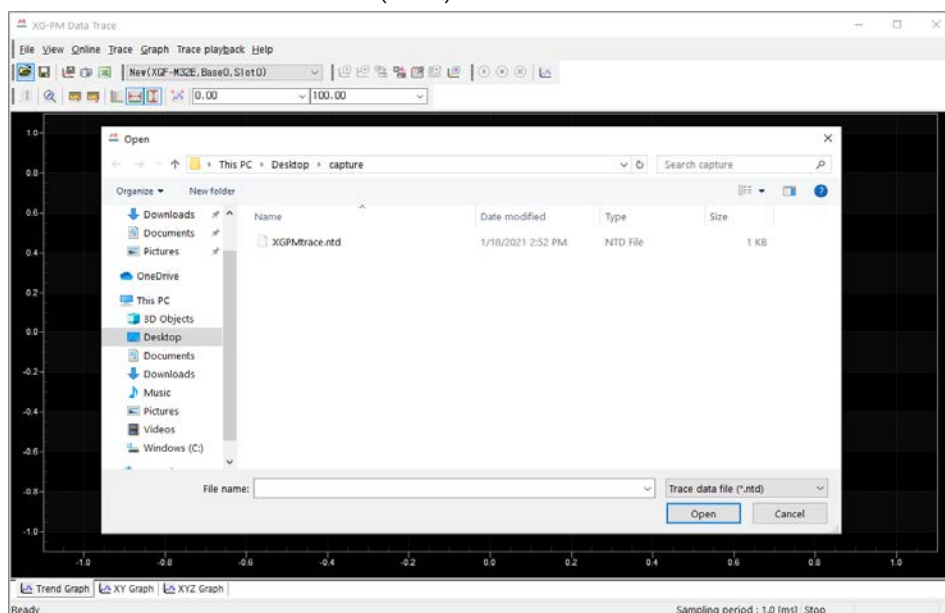

b. As shown in the figure below, you can view the previously saved trace results again.

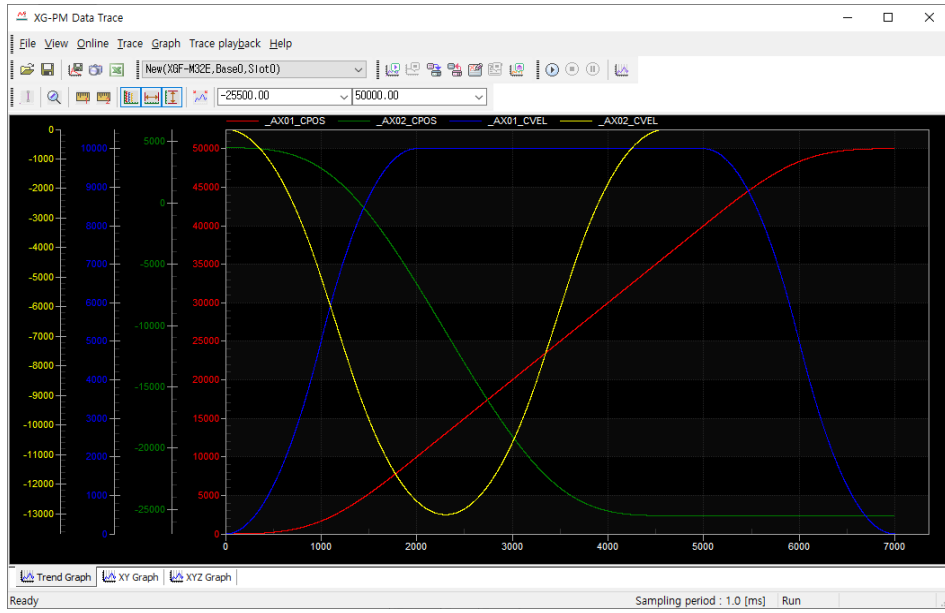

Note

If the module type is different, the trace data is not compatible.

When reading trace data from a file If the currently set module and the module type stored in the trace data are different, the following data compatibility-related message is displayed and the file cannot be opened.

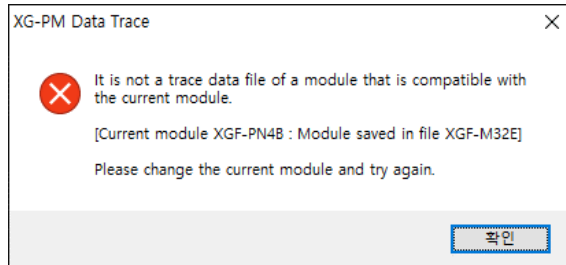

(3) XGF-PNxB, XBF-PN0xB-EtherCAT slave auto-connection function improvement using ESI file

- In the past, EtherCAT slaves other than the 5 company's EtherCAT slaves included in XG-PM and module OS do not support automatic connection function. There was a cumbersome aspect to perform the connection function separately.

By improving this, after searching for a slave on the current EtherCAT network, if there is a corresponding slave ESI file in the XG-PM folder, EtherCAT parameters can be written and connected automatically.

-In the improved function, if you place the ESI file of the slave you want to connect to in the folder where the ESI file is located, restart the XG-PM application and perform automatic connection to the EtherCAT slave, you can automatically search and connect the currently connected slave.

- 1) Locate the ESI file
 - a. Place the mouse on the EtherCAT slave tree in the [ESI Library] tab and right-click the mouse.
 - b. Run the [ESI File Folder] menu. The ESI file folder referenced by the current XG-PM application is displayed on the Windows Explorer.
 - c. Copy the ESI file of the newly connected slave to the corresponding folder.
 - d. Restart XG-PM.
 - e. Information of the ESI file added on the EtherCAT slave tree of the [ESI Library] tab is displayed.

- 2) Execution of automatic connection
 - When automatic connection is performed, the following process is performed.
 - a. Send slave auto search command: Requests the information of the slave currently connected to the module.
 - b. Read Slave Information: Reads the currently connected EtherCAT slave information.
 - c. Write network parameters: Based on the currently connected slave information, XG-PM configures network parameters and downloads them to the module.
 - d. Slave connection command transmission: The connection command for EtherCAT connection is transmitted based on the downloaded network parameters.
 - e. Servo parameter read: After connection is completed, the parameter information of the currently connected slave is automatically read.

Note

EtherCAT slave automatic connection function using ESI file is supported by XGF-PNxB, XBF-PN0xB OS version 2.1 or higher.

(4) XGF-PNx B, XBF-PN0xB-Added editing function to support EtherCAT PDO data write/read function with GETM/PUTM instruction from CPU

- In order to directly read or write the status of servo parameters in the positioning module, there are constraints on adding commands and using commands. To alleviate this inconvenience, EtherCAT PDO data writing/reading function through GET/PUT command was added, and an editing function to set the corresponding parameter in XG-PM was added.

[RxPDO: Write CPU data]

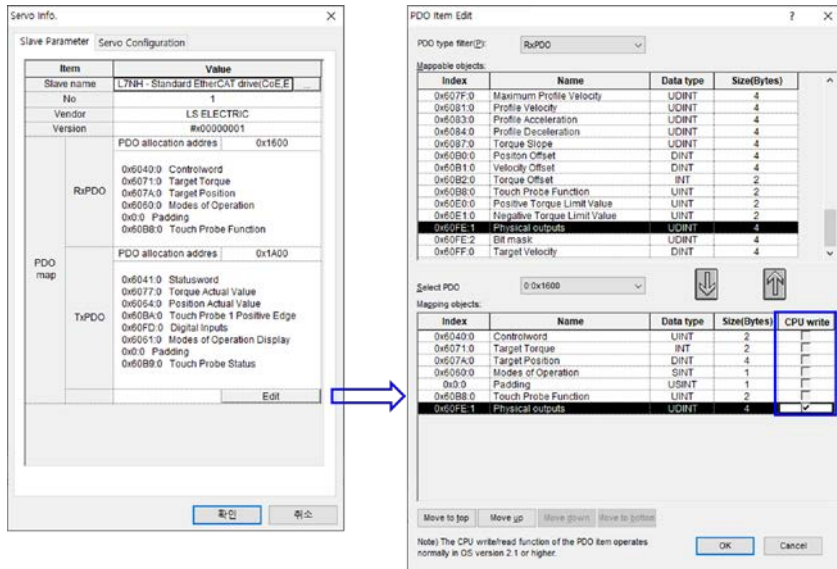

[TxPDO: Read CPU data]

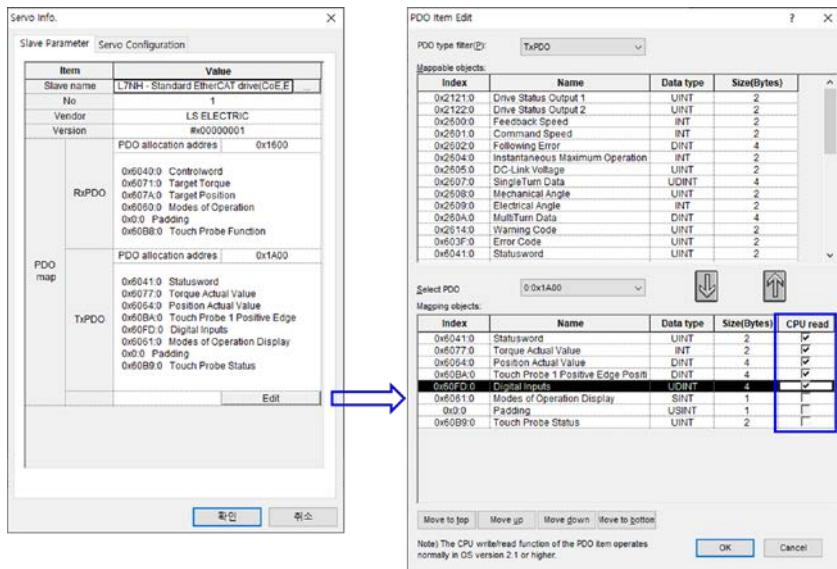

Note
The function of writing/reading EtherCAT PDO data from CPU with GETM/PUTM instruction is supported by XGF-PNx B, XBF-PN0xB OS version 2.1 or later.

(5) Add operation parameter and servo parameter write and save function during axis operation or servo ON

- In order to improve user convenience, the following functions that were previously restricted in the positioning module have been improved.

- 1) It is possible to write operation parameters during operation or while the servo is on.
- 2) It is possible to write servo parameters while the servo is on.
- 3) Servo parameters can be saved in the servo-on state.
- 4) The version guide in which the corresponding function is operated is placed on each screen so that customers can easily check it.
- 5) On the servo parameter screen, parameters that cannot be changed when the servo is turned on are displayed.

[Write project]-Support version guide

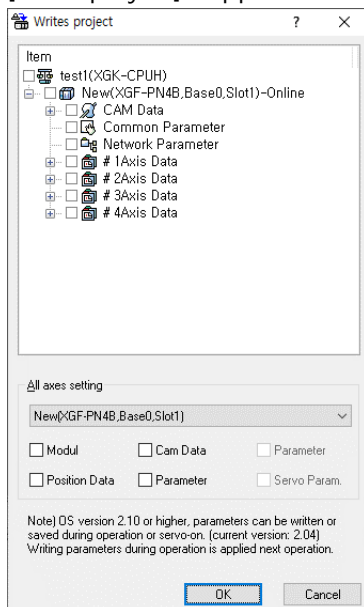

[SDO (Servo) parameter write and save]-Support version guide

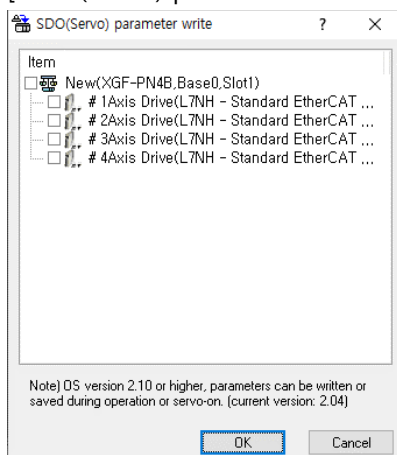

[Servo parameter screen]-Display parameters that cannot be changed

Index	Name	Unit	Current Value
2000	Motor ID*	-	13
2001	Encoder Type*	-	2
2002	Encoder Pulse per Revolution*	pulse	524288
2003	Node ID	-	-
2004	Rotation Direction Select	-	0
2005	Absolute Encoder Configuration*	-	1
2006	Main Power Fail Check Mode	-	0
2007	Main Power Fail Check Time	ms	20
2008	7SEG Display Selection	-	0

Note
 The functions of writing operation parameters and writing and saving servo parameters during operation or while servo on are supported in XGF-PNxB, XBF-PN0xB OS version 2.1 or higher.

(6) XGF-PN8B slave revision check function added

When connecting to EtherCAT, which was supported only in XGF-M32E module, a master option function that can check or not check the slave revision has been added.

Even if the ESI (EtherCAT Slave Information) file provided by some vendors and the version on the actual device do not match, it is possible to operate or check the slave after performing EtherCAT connection.

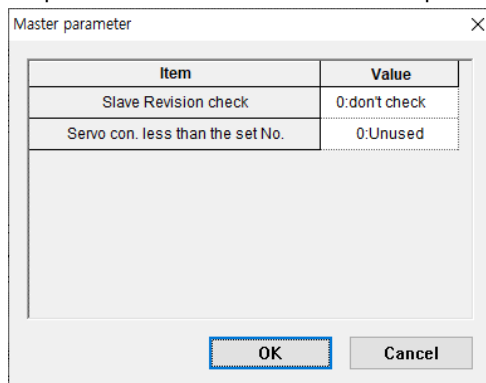

(7) Added INIT_DONE instruction in XGF-M32E

The INIT_DONE command and related flags (_INIT_DONE and _INIT_RUN) that can be used usefully when the initialization task is used for parameter initial value setting and basic operation addition have been added.

The initialization task is executed until the _INIT_DONE flag is On, and after it is On, the initialization task operation ends and the main task is executed.

To use this function, select [Basic parameter]-[Init task action setting] to _INIT_DONE and use it after downloading.

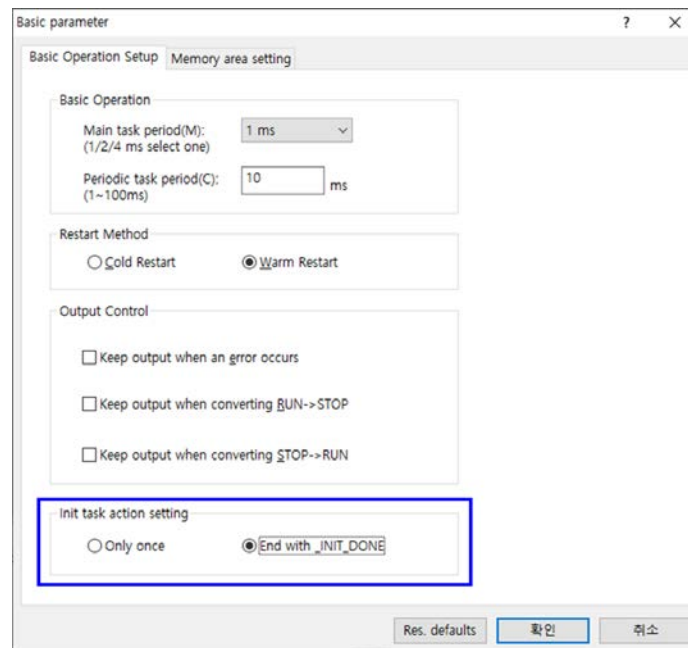

Note

The function of setting the operation of the initialization task through the `_INIT_DONE` flag is supported in XGF-M32E OS version 1.4 or higher.

(8) XGF-PNxB, XBF-PN0xB-Provide control time information and add control cycle user setting function

As the module control time increases as various functions of the module are added, the control cycle is exceeded. Accordingly, for the stable operation of the control, the user checks the actual control time, and if the control cycle is exceeded, the user recognizes and then a function to reset the control cycle has been added.

1) Control period user setting

- a. The control period can be set through [Common parameter] – [Control period] parameter.
- b. Each value (0~4) of 'control period setting' has the following meaning.

- 0: Auto
- 1: 1ms
- 2: 2ms
- 3: 3ms
- 4: 4ms

알아두기

The control period for [Auto] is as follows.

Control Period(ms)	XGF-PN4B	XGF-PN8B	XGF-PN04B	XGF-PN08B
1	1~2 Axis	1~2 Axis	1~2 Axis	1~2 Axis
2	3~4 Axis	3~6 Axis	3~4 Axis	3~5 Axis
3	-	7~8 Axis	-	6~8 Axis

2) Confirmation of control period information

- a. The value of [Current Control Cycle] can be checked through Online-Module Information-Performance tab.
- b. You can check the current control time and maximum control time information as well as the control cycle setting.
- c. If the control period set in the common parameter is exceeded, it can be checked through the control period exceeded status information.

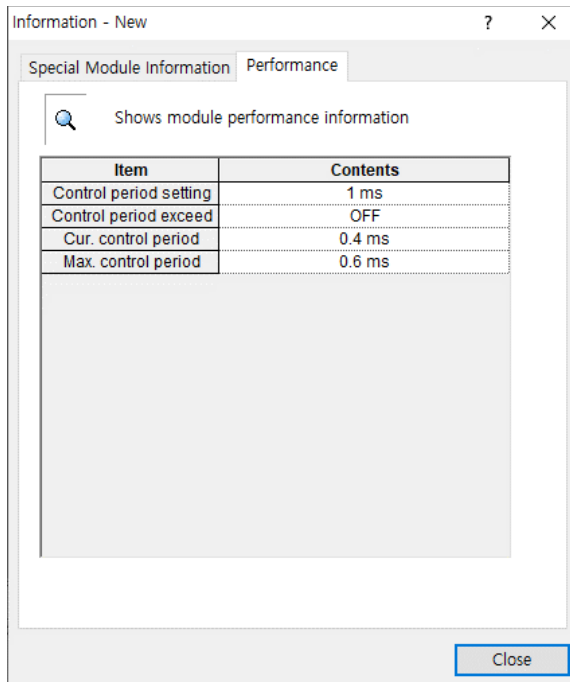

Note

Control cycle setting and information check are available in XGF-PNx B, XBF-PN0xB OS version 2.1 or higher.

(9) XGF-M32E, XGF-PNxB, XBF-PN0xB – Added SDO read selection option when connecting to EtherCAT automatically

When the EtherCAT is automatically connected, SDO read is automatically performed. In some slaves, the number of SDOs is very high, so it takes a long time. By improving this, we added the ability to select SDO reading when automatically connected.

1) Selecting and canceling the SDO read option

Whether to include read or not can be set in the Network Slave Autoconnect confirmation dialog box.

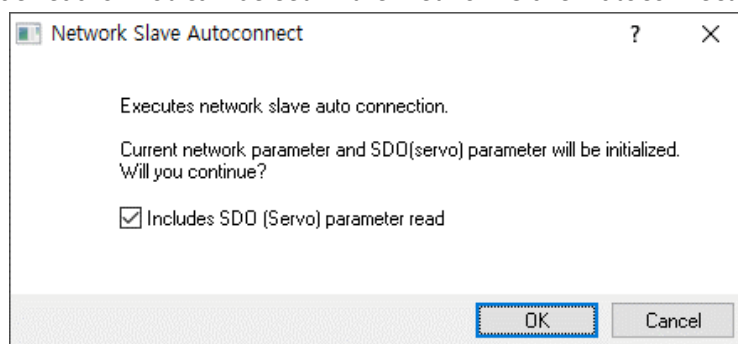

Note

SDO read option can be saved in each module of project when saving project file.

■ ReleaseNote - XG5000 V4.51

1. Improvements and additions

(1) Improved the function of adding items in the project tree (XMC)

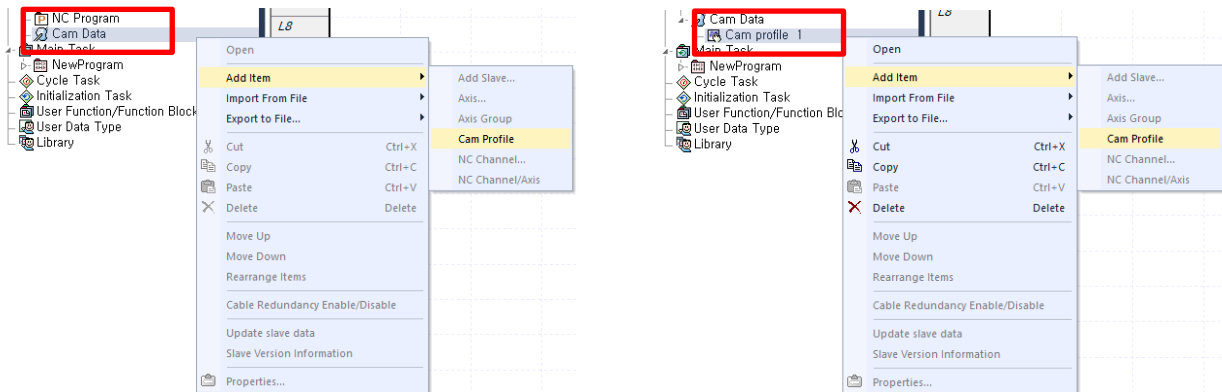

Ex) It is possible to add a cam profile in the cam data, and to add a cam profile in the cam profile. Slave, axis, axis group, NC channel, cam profile, etc. are available

(2) LD editor address editing priority function added

This function is used to specify the priority for editing when a variable/device is mixed in the user program. The set options are applied when editing directly or editing variables.

[Steps]

Select 'Show all' as the view menu. Select [Edit] – [Edit Address Priority(View All)].

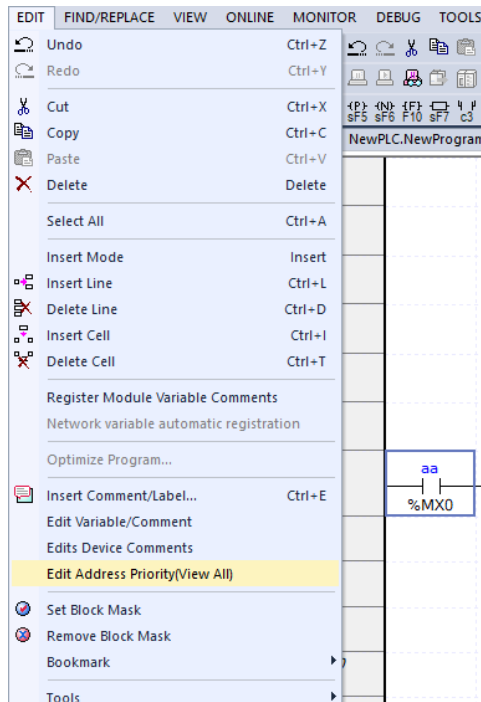

It can also be set in the XG5000 [Tools] – [Options].

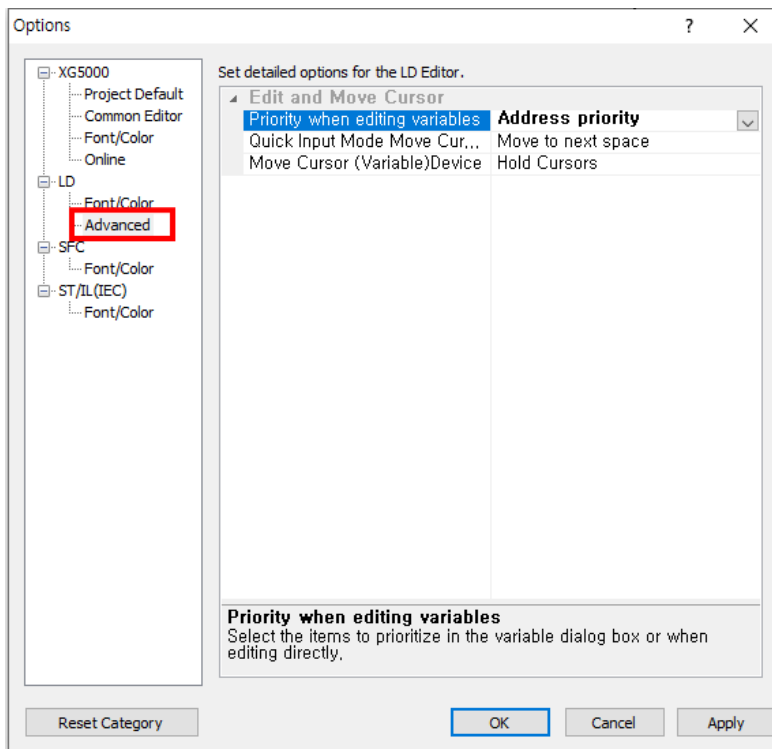

[Note]

If View mode is not [Show All], it's prioritized according to the View mode.

- Device , Device/Variable, Device/Comment: Edit Device first
- Variable, Variable/Comment: Edit variable first
- Show All : Depends on option

(3) Export multiple user functions/function blocks to File and Import multiple user functions/function blocks form File

[Steps - Export]

1. Select the function block to be exported.

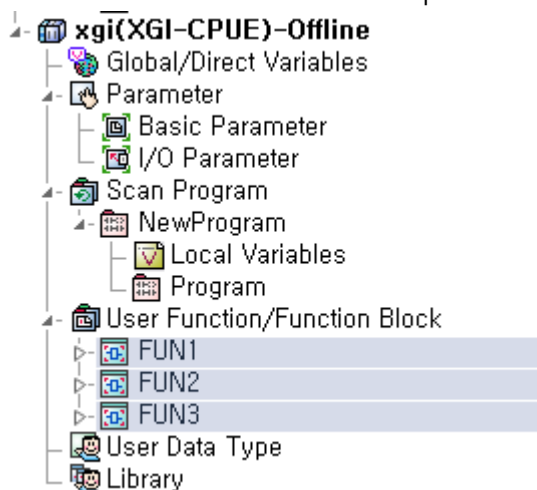

2. Click the right button and select [Export to File...].

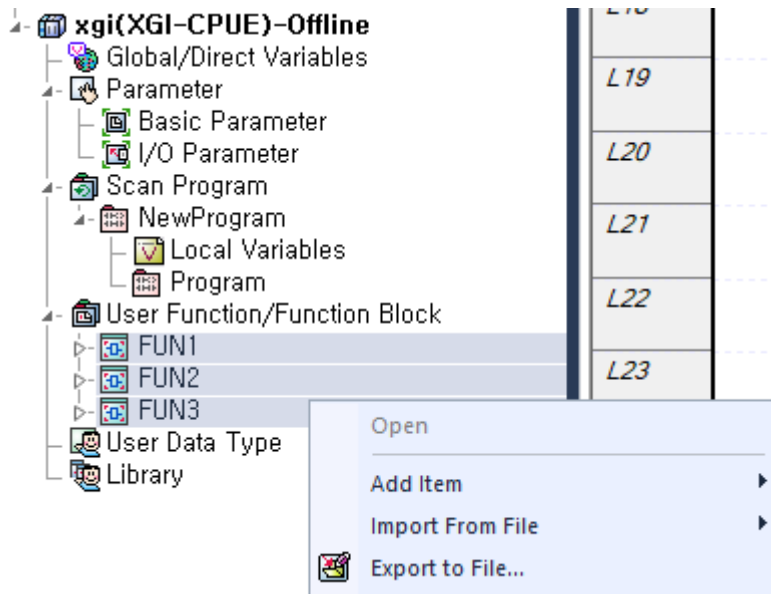

3. Select the folder where the file will be saved.

[Steps - Import]

1. Select the [Import From File] – [Function/FB].

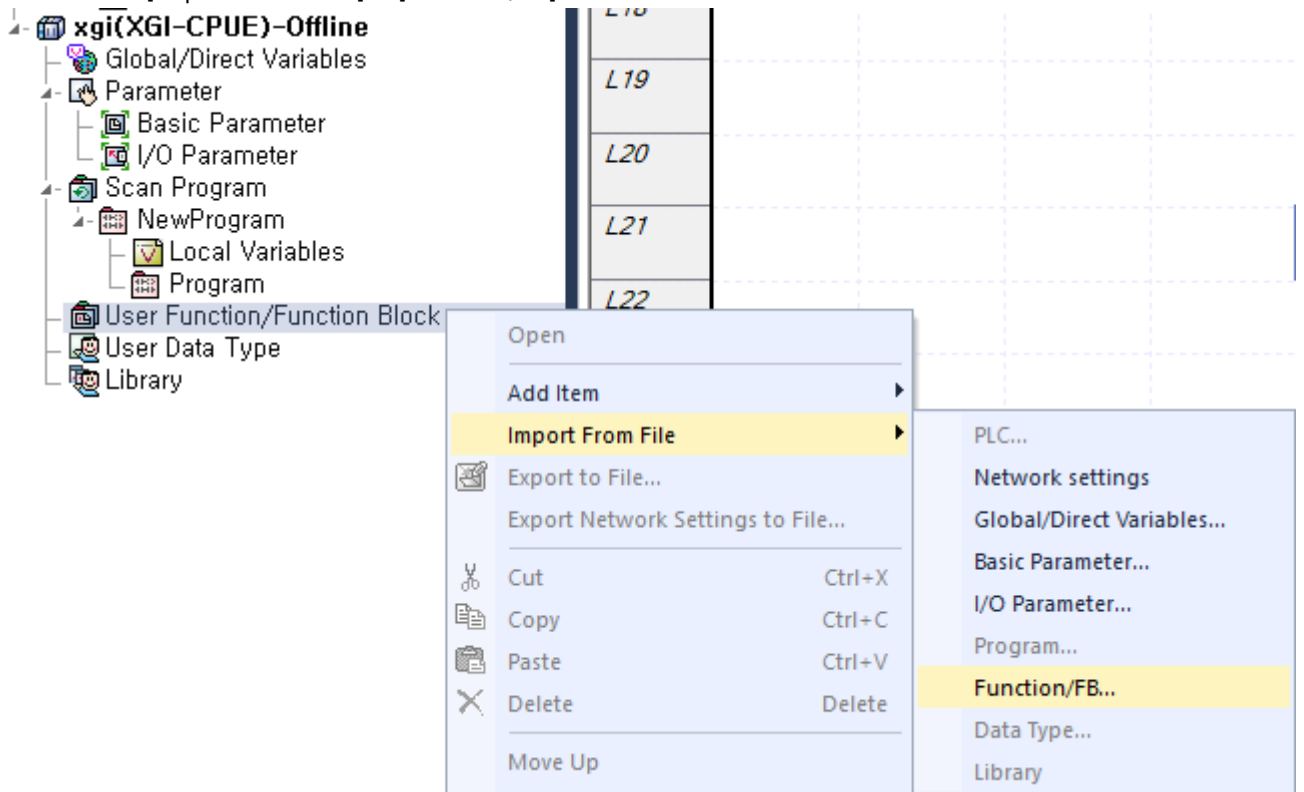

2. In the file dialog, select the user function/function block you want to add and click the OK button.

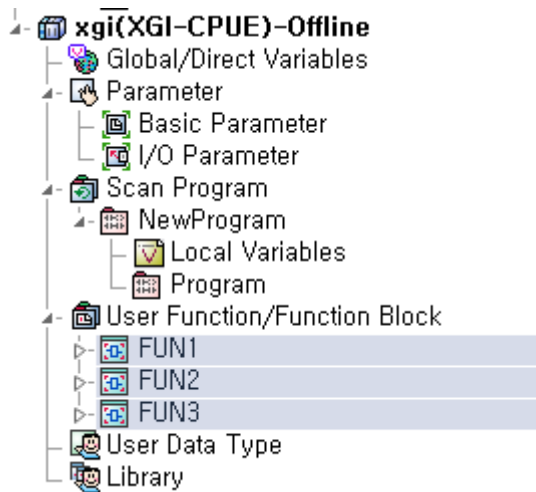

[Note]

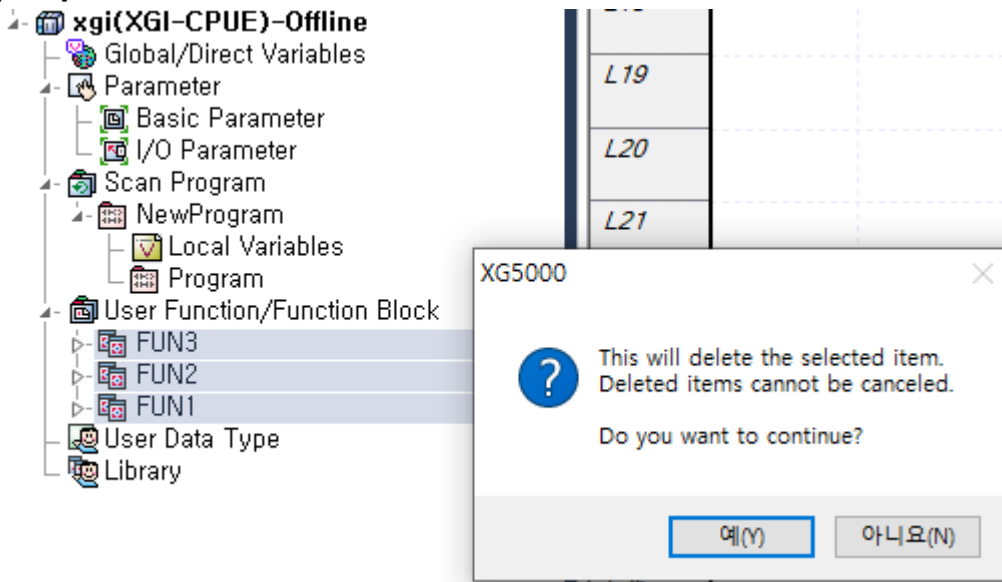

(4) Keyboard Map

[Steps]

1. Click the menu. [Help] – [Keyboard Map...]

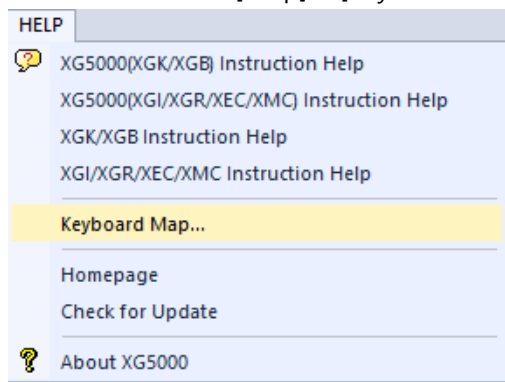

Command	Keys	Description
DebugGo	Ctrl+F9	Runs the program.
DebugGoToCursor	Ctrl+F2	Runs to cursor.
DebugSet/RemoveBreakpoints	Ctrl+F5	Sets or remove a breakpoint.
DebugStepInto	Ctrl+F7	Steps into the user defined function/function block.
DebugStepOver	Ctrl+F8	Executes a single command.
EditAddLine(M)	Ctrl+M	Add a line above the selected line.
EditBookmarkSet/Remove	Ctrl+B	Sets or remove a bookmark.
EditCopy	Ctrl+C; Ct...	Copies the selection to the Clipboard.
EditCut	Ctrl+X	Cuts the current selection and saves it to the Clipboard.
EditDelete	Delete	Deletes the selection.
EditDeleteCell	Ctrl+T	Deletes a cell from the editor.
EditDeleteLine	Ctrl+D	Deletes a line at the current position.
EditInsertCell	Ctrl+I	Inserts one cell in the LD editor.
EditInsertComment/Label...	Ctrl+E	Inputs comment or label.
EditInsertLine	Ctrl+L	Inserts a line at the current position.
EditInsertMode	Insert	Changes the Program Edit Mode to Insert Mode.
EditPaste	Ctrl+V; Sh...	Inserts the Clipboard contents at the insertion point.
EditRedo	Ctrl+Y	Redo last cancelled action.
EditSelect/AddVariable	Ctrl+1	Select or add a variable to local variables window.
EditSelectAll	Ctrl+A	Selects all items.
EditToolsAction	F4	Inserts action.

[Note]

- 1: This function copies the selected item as text.
- 2: You can display the menu item by item.

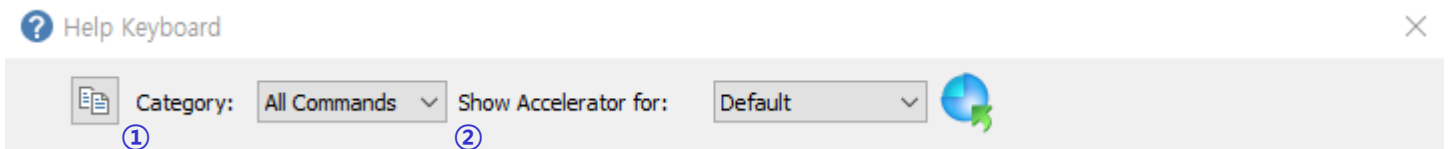

(5) Password setting function for each program (IEC Project)

- This is a function to set the password for each program in the IEC project.

[Steps]

1. Select the program to set the password for.
2. Click the right mouse button and select "Properties..."

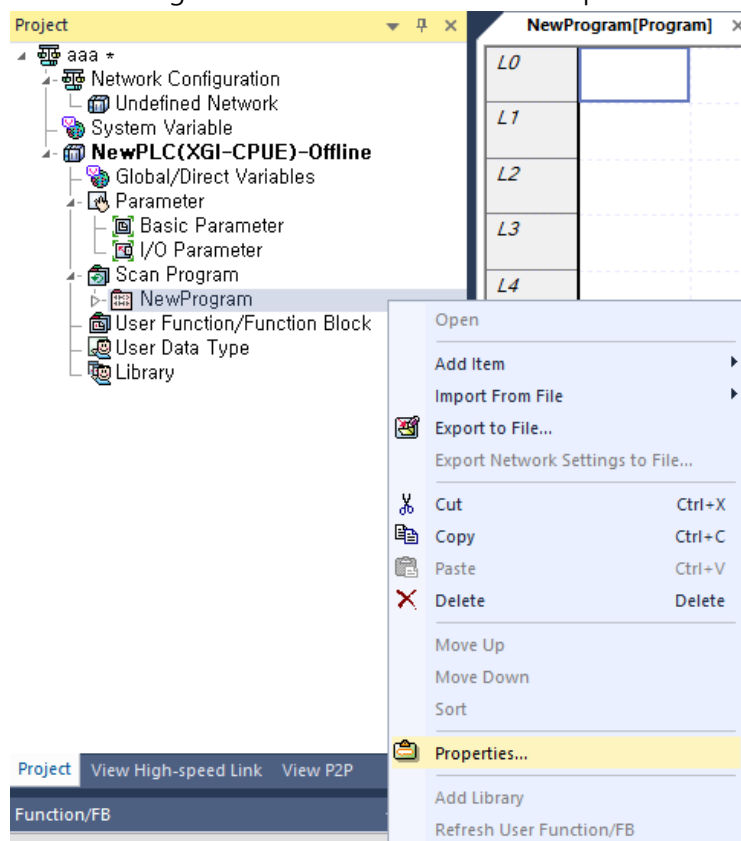

3. On the Password tab, enter a new password and confirm password. Supports passwords of up to 8 characters.

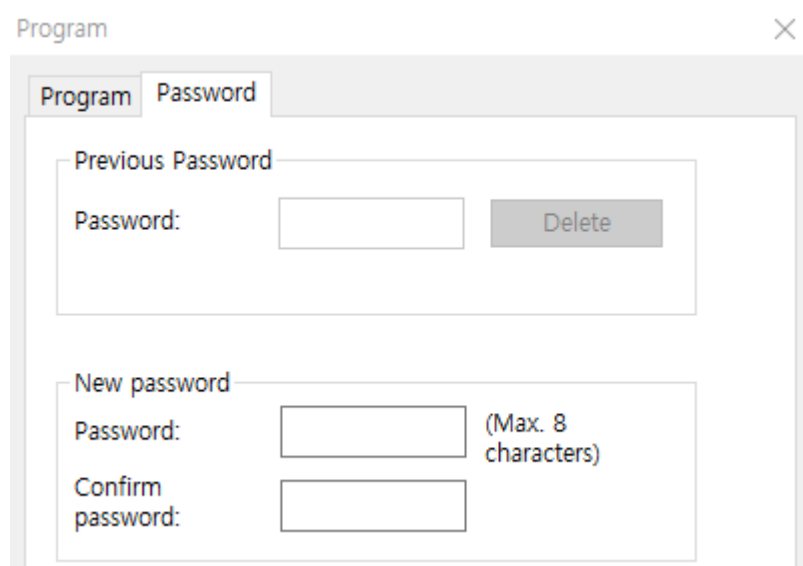

4. If you double-click an item in the project tree, the [Confirm Password] dialog box is displayed.

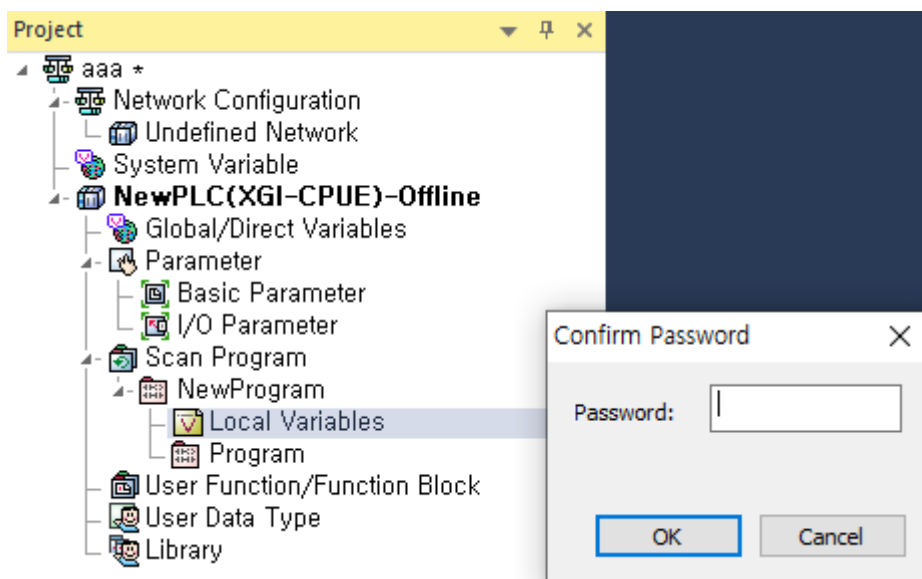

[Note]

1. To support passwords varies by project type.

XGK/XGB - support

XGI/XEC - support

XGK/XGB Auto-allocation - Not supported

2. If password is set, this function is limited in the lower XG5000 version. (The project does not open.)

3. Programs with a password set are not printed.

(6) Communication module name setting function

This is a function to set and display the name of the communication module in the network configuration within the project tree.

[Steps]

1. Add a communication module to the project tree.
2. Click the right mouse button and click on the "Properties..." item.

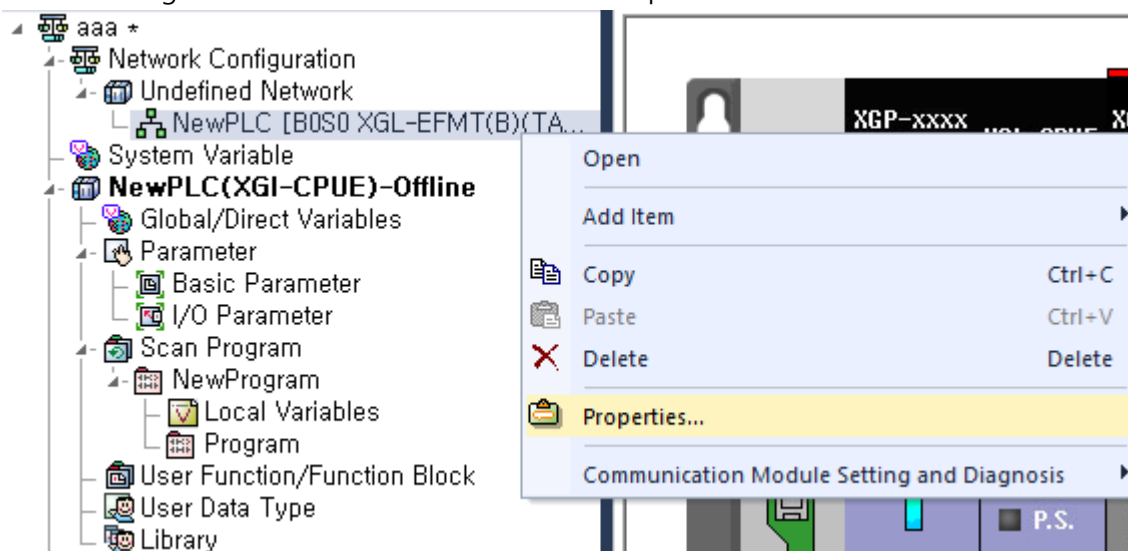

3. Fill in the name and comment and click the OK button.

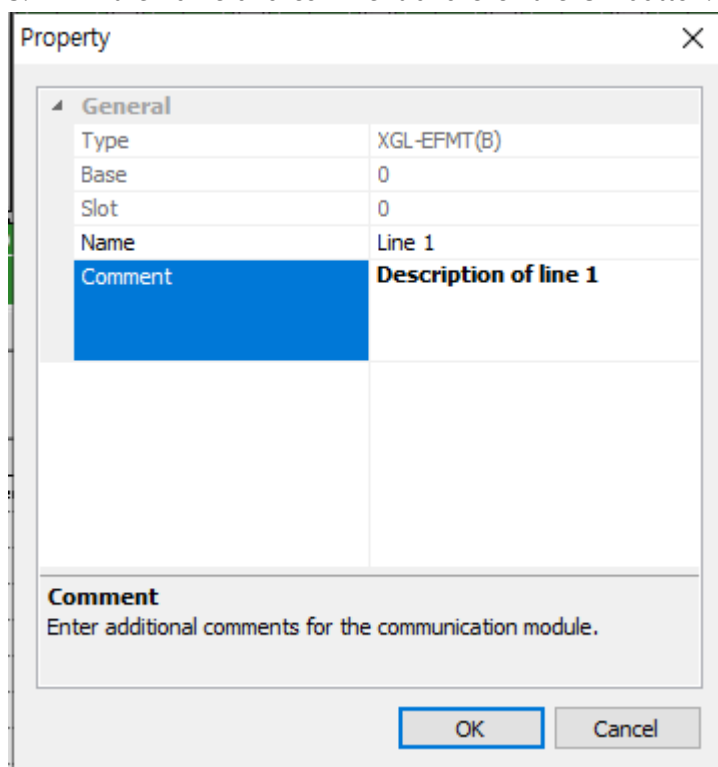

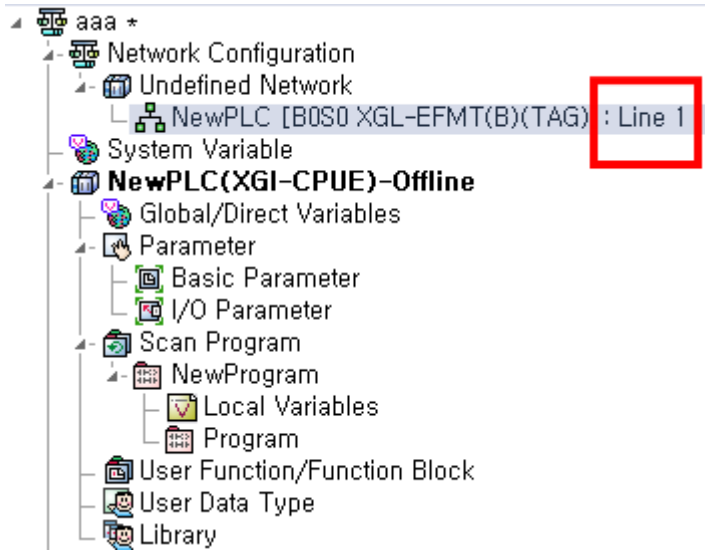

[Note]

1. All types of characters are entered.
2. There is no limit to the length that can be entered.
3. The entered information is saved in the upload or comment area.

(7) Smart extension EB base name setting and display function

[Steps]

1. Add the Smart Extension.
2. Click the [New] to add an extension base. The communication device name can be changed in [Basic parameter].

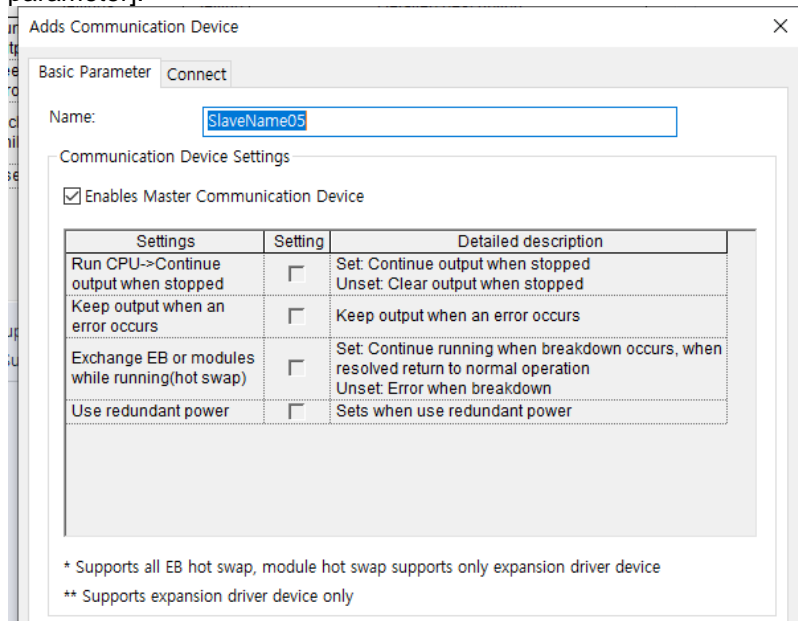

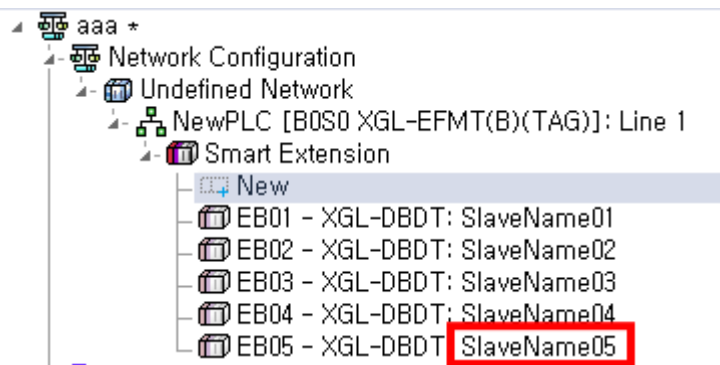
**[Note]**

The name of EB(Extension base) applies the same as the variable rules.

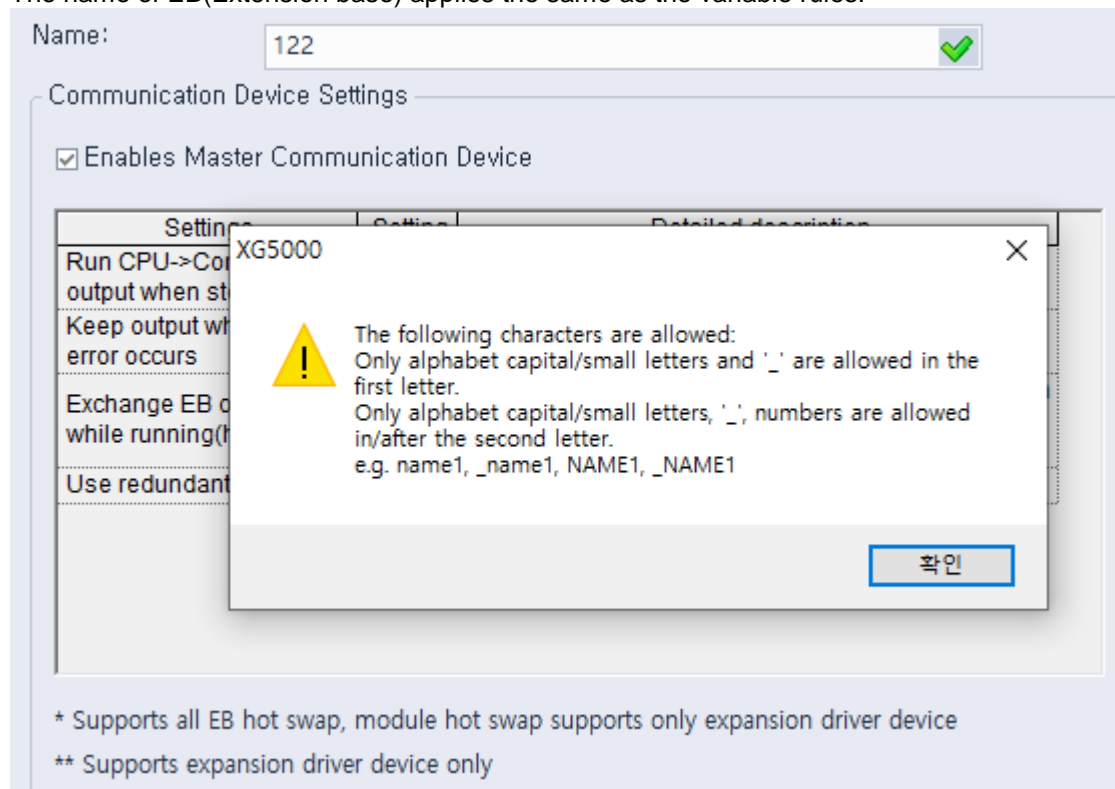

(8) Improved [Allocate Input/Output Variables] and [Allocate Diagnostic Variables] of the Smart Expansion.

Editing functions (copy, delete, paste, cut) have been added for the device column in the [Allocate ~ variable] window of the smart extension. After allocating a new device, you can select all devices to use the copy, delete, paste, and cut functions.

(9) Improved editing of [module variable]

Editing functions (copy, delete, paste, cut, Undo/Redo, AutoFill) have been added to the variable and comment column for the global variable added through the menu[Register Module Variable Comments]. – Editable columns are displayed with a white background.

(10) Improved the memory allocation of user data type

In the case of memory allocation for user data type variables, we have improved to enable direct variable types of all types (BOOL, BYTE, WORD, DWORD, LWORD) from the formerly only available in LWORD type direct variable type. (However, it must be set to 64-bit size. %MB1, %MB2 not available, %MB0, %MB8 available)

(11) Added the [Synchronize] function in Smart Extension

[Synchronize] function has been added in the [Allocate Input/Output Variables] and [Allocate Diagnostic Variables] windows. If the address registered in the global variable and the address of the smart extension are the same, the global variable name and description are displayed.

(12) Improved the Online Editing about the global variables.

In the IEC project, online editing function for global variables has been added. When a global variable is modified, all programs referencing the variable are changed to edit status. However, it is not possible to modify the global variables used in the user function and user function block.

(13) Improved the address display of user data type

When an address is directly assigned to the user data type, a function to change the address display method has been added. This function is provided as a context menu in the grid window.

If you click the [Initial Value] after allocating memory to the user data type variable from the local variable, the user data type item setting window is created.

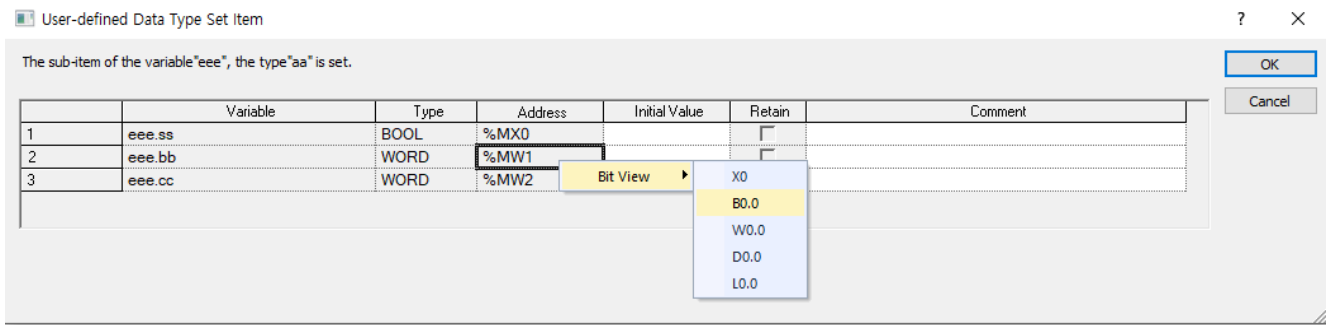

(14) View [ANY Type Function]

A function to select ANY type support instructions from the function/function block list has been added.

CPU Series: XGI, XMC

Language: LD

[Steps]

1. Check the [View ANY Type Function] in the Function/Function Block.

All function/function blocks for each data type that were automatically hidden are displayed in the function list.

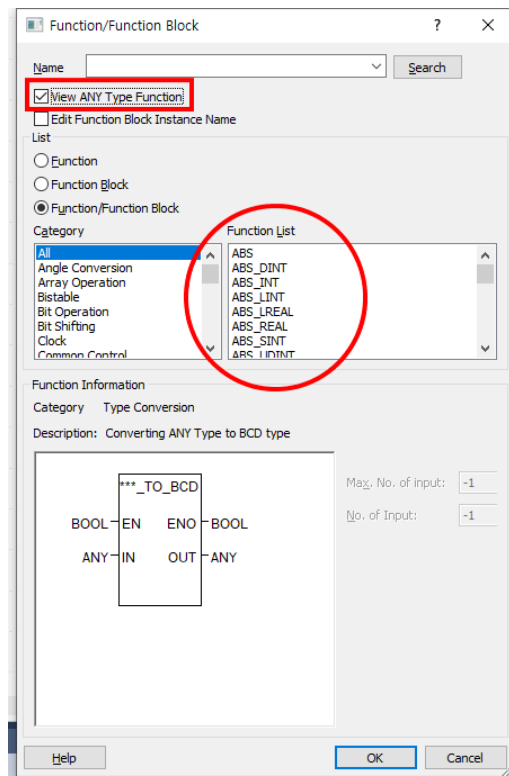
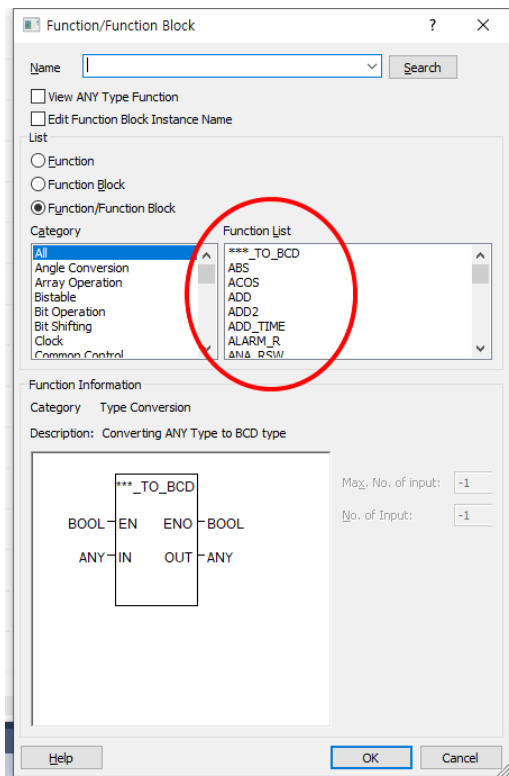

(15) Added a function that can be modified about [Edit Function Block Instance Name]

This is a function that improves the convenience of modifying the function block instance name by placing the initial cursor position on the [Instance Name] in the Function/Function block dialog box.

[Steps]

1. Click the [Edit Function Block Instance Name].
2. When modifying the function block in use, the default cursor position moves to [Instance name].

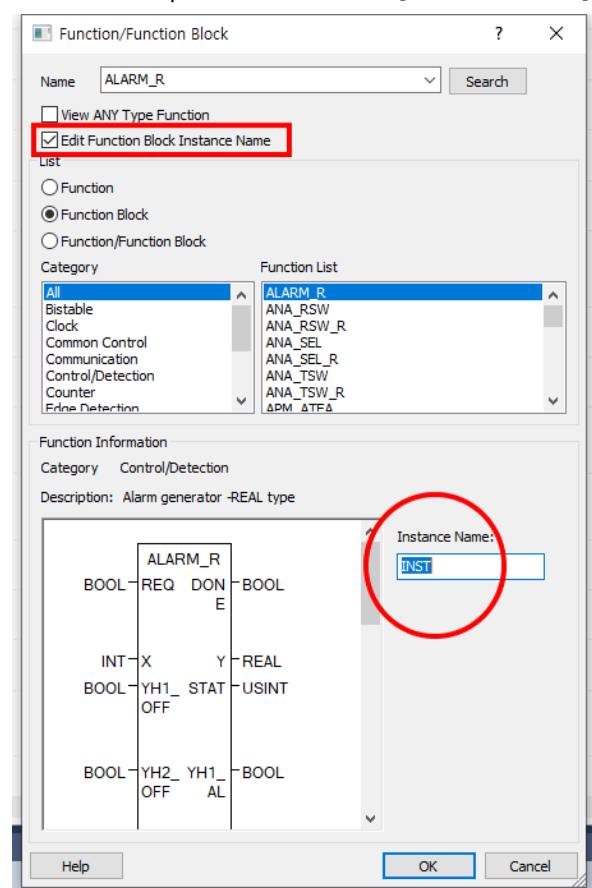
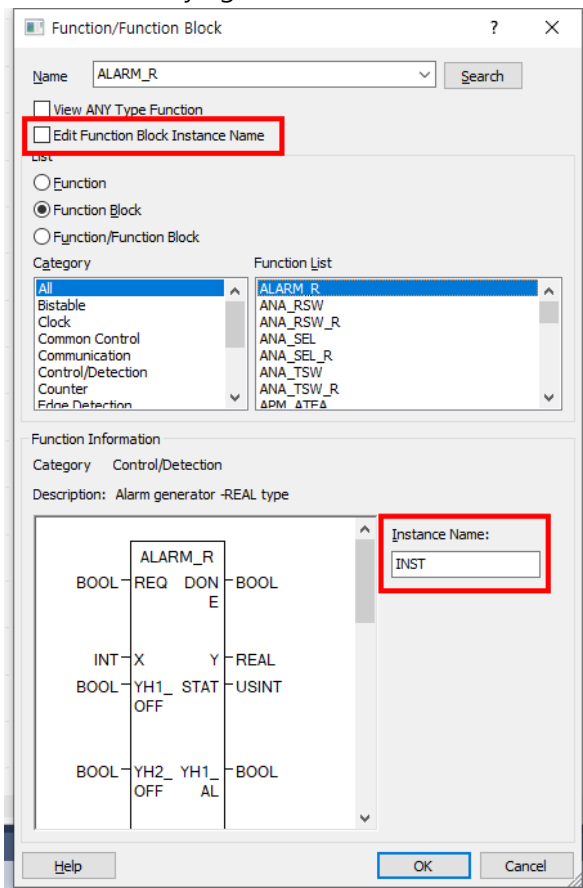

(16) Added the Receive Timeout function in High-speed Link Communication

When adding a high-speed link, it provides the function to set the receiving timeout value in the high-speed link basic setting dialog box. If you press the [Advanced Settings] button in the communication module setting and diagnosis, the initial value is displayed as "Default value".

[Steps]

1. Select the [Add Item] – [High-speed Link Communication] in the project tree.

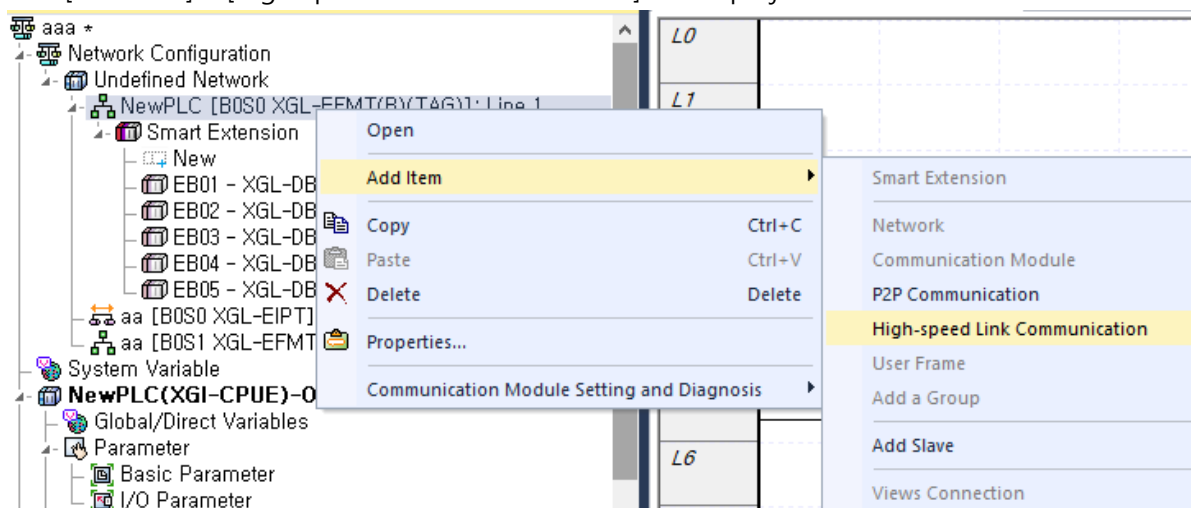

2. Click the [Advanced Settings] in the Communication Module Setting and Diagnosis dialog box.

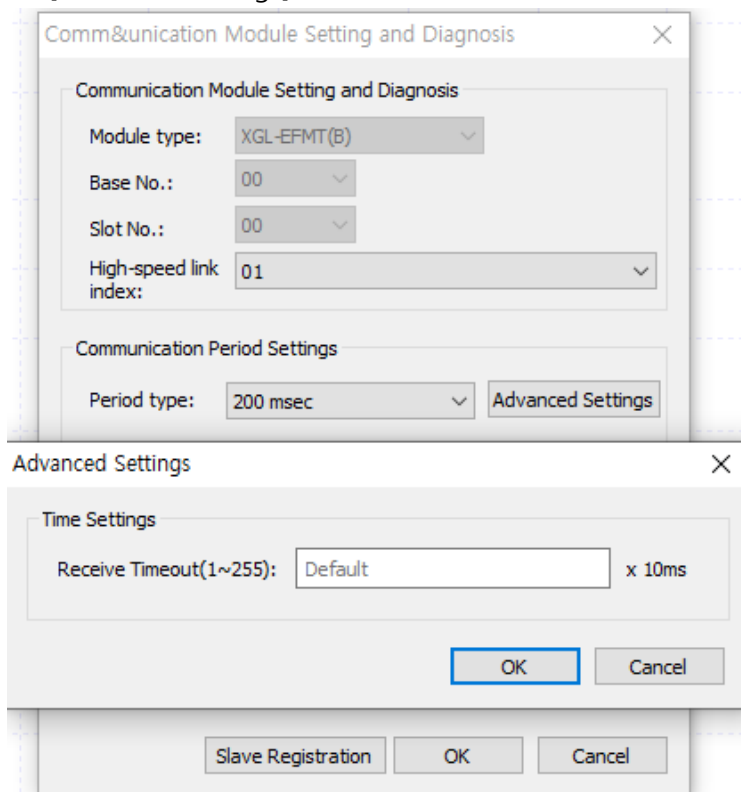

- Set the Receive Timeout value and click the [OK] button. The Receive Timeout value can be input from 1 to 255.

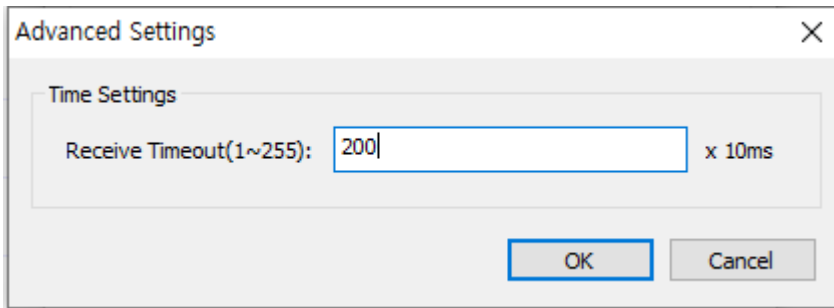

(17) Added the IP conflict warning function in XMC

In case of local Ethernet IP address conflict in XMC type models, the error/warning and error history window displays the error code content and the corresponding IP conflict error message in the details and action items.

(18) Added the variable filtering function in the UDF/UDFB

Filtering by item is provided in the UDF and UDFB's local variable setting window. Filtering by the content of the star field, filtering by keyword, and sorting in ascending/descending order are available.

[Steps]

- Select the [Add Item]-[Function] or [Add Item]-[Function Block] in User Function/Function Block menu.

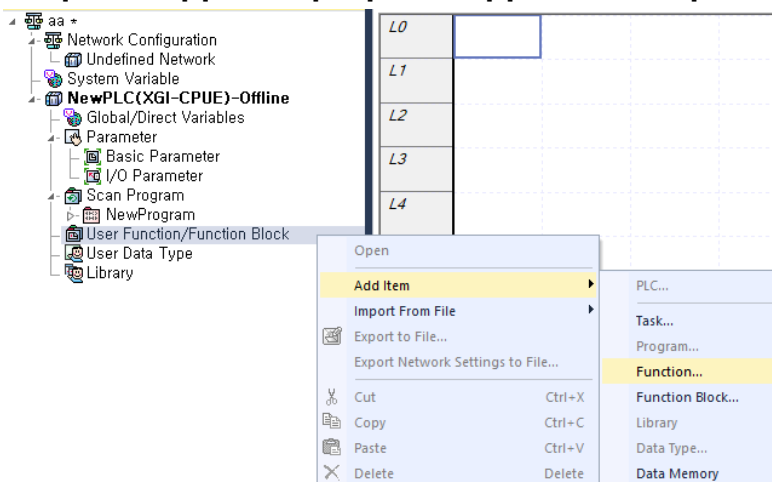

- Expand the added function/function block item and double-click the lower local variable item to display the local variables window. Set the variable in the local variables window.

	Variable Kind	Variable	Type	Used	Comment
1	VAR_RETURN	aa	BOOL	<input type="checkbox"/>	
2	VAR_INPUT	cc	WORD	<input type="checkbox"/>	cc
3	VAR_INPUT	bb	BYTE	<input type="checkbox"/>	bb
4	VAR_OUTPUT	dd	BYTE	<input type="checkbox"/>	dd
5	VAR_OUTPUT	ee	DWORD	<input type="checkbox"/>	ee
6				<input type="checkbox"/>	

3. Click on the header of a column to display the filtering window.

	Variable Kind	Variable	Type	Used	Comment
1	VAR_RETURN	aa	BOOL	<input type="checkbox"/>	
2	VAR_INPUT	cc	WORD	<input type="checkbox"/>	cc
3	VAR_INPUT	bb	BYTE	<input type="checkbox"/>	bb
4	VAR_OUTPUT	dd	BYTE	<input type="checkbox"/>	dd
5	VAR_OUTPUT	ee	DWORD	<input type="checkbox"/>	ee
6				<input type="checkbox"/>	

Sort Descending
Sort Ascending
Custom Filter...
Clear Filter

- (Select All)
- aa
- cc
- bb
- dd
- ee

OK Cancel

BOOL | EN ENO | BOOL

4. If you want to see only the items you want to display among the list items below, select/clear the check and click the [OK] button.

	Variable Kind	Variable	Type	Used	Comment
1	VAR_RETURN	aa	BOOL	<input type="checkbox"/>	
2	VAR_INPUT	cc	WORD	<input type="checkbox"/>	cc
5	VAR_OUTPUT	ee	DWORD	<input type="checkbox"/>	ee
6				<input type="checkbox"/>	

5. If you select the [Custom Filter], the [Filtering by column "Name"] window is displayed. If you press the [OK] button after entering the keyword you want to search/display, the items in the column corresponding to the entered keyword are filtered and displayed. If you want to cancel the custom filter, select the [Clear Filter].

Filtering by column "Name" ✕

Enter a text string to filter the contents of the grid control. The grid displays only the items that contain the specified string in the column, "Name".

6. If the column is [Sort Descending] while it is filtered, a user message is displayed. If you press the [ok] button, the filtered items are sorted and displayed in descending order. If filtering is not used, [Sort

Descending] will sort the entire item in descending order.

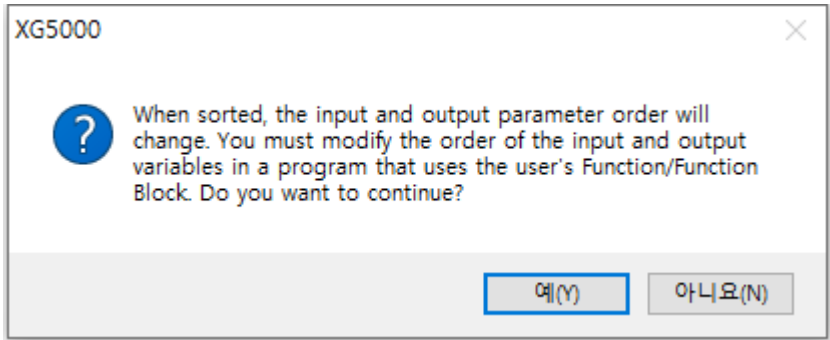

	Variable Kind	Variable	Type	Used	Comment
1	VAR_OUTPUT	ee	DWORD	<input type="checkbox"/>	ee
3	VAR_INPUT	cc	WORD	<input type="checkbox"/>	cc
5	VAR_RETURN	aa	BOOL	<input type="checkbox"/>	
6				<input type="checkbox"/>	

* Warning *

1. If you change the input and output parameters of the variable of the user function/function block, you cannot undo the existing alignment.
2. If the input and output variables of the user function/function block are changed and reflected in the scan program through the [Refresh User Function/FB], I/O variables of the user function/function block previously created in the scan program must be adjusted according to the modified I/O variables. It must be adjusted according to the parameters. **(Input/output variables are not automatically changed according to the order of the changed parameters.)**

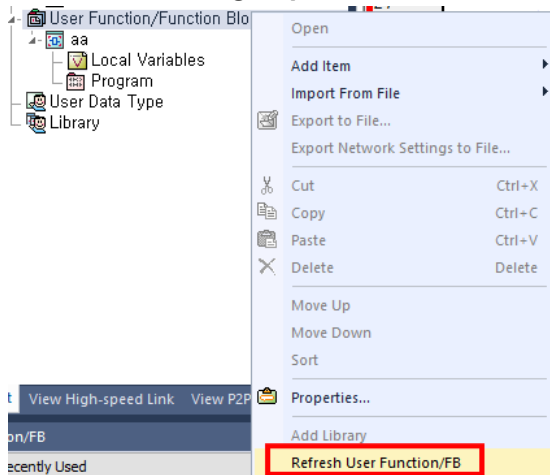

(19) Added the variable filtering function in global variable

Filtering by item is provided for the global variable window. You can use filtering according to column content, filtering according to keywords and sorting in ascending/descending. Filtering function has been added for the [Direct Variable Comment] and [Flag] menu.

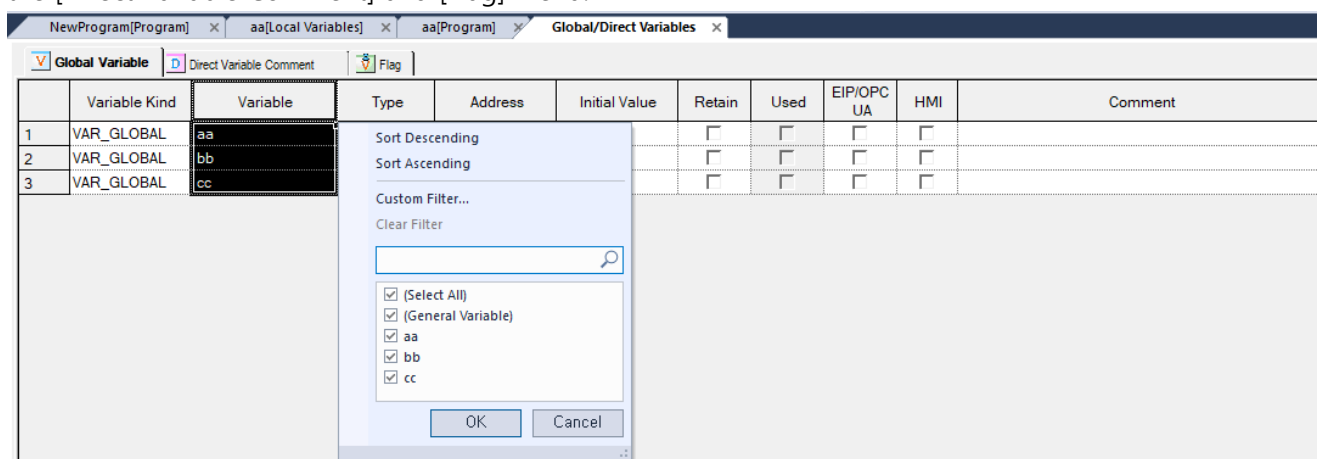

(20) Refactoring(Rename Symbol)

[Rename Symbol] supports renaming of global and local symbols. Right-click the variable whose name you want to change in the variable window or editor, and then change it through [Refactoring]-[Rename Symbol].

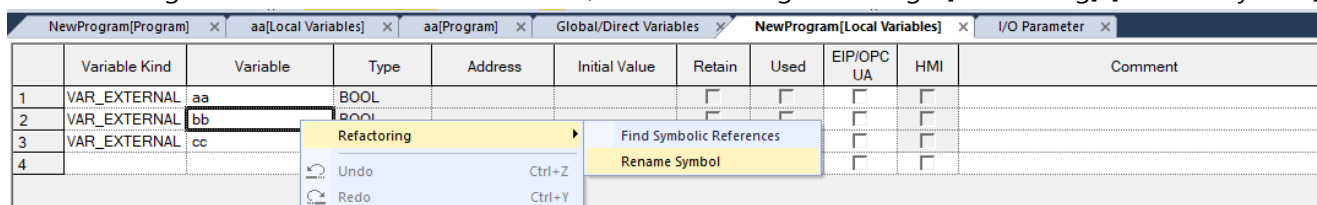

When you click [Rename Symbol], all items in which the variable is used are searched and displayed.

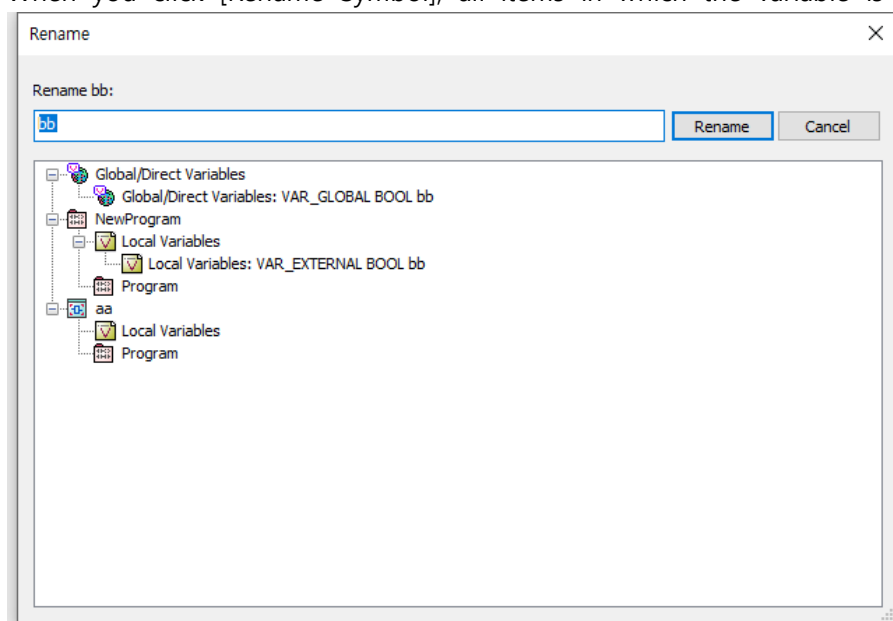

In the case of local variables and user function blocks, it is searched only in the local variable window and program.

If you double-click the searched item, you can move to the item.

After changing the name, click Change to change the name of the variable and you can check it in the result window. Also, you can double-click an item in the result window to move to that location.

(21) Refactoring(Rename Symbol in Online Editing mode)

Right-click the variable whose name you want to change in the editor or in the variable window in Online Editing mode, and then click [Refactoring]-[Rename Symbol].

Symbols such as global symbols or flags used in user function blocks cannot be modified during run and are displayed in gray as shown below.

1	VAR_GLOBAL	g_bool_rename	BOOL				<input checked="" type="checkbox"/>			
2	VAR_GLOBAL	g_bool_used_in_fb	BOOL				<input checked="" type="checkbox"/>			
3										

(22) Added the [Hold Cursors] function when editing

When entering a Contact or Coil, a function to keep it in place has been added.

This function can be used when canceling the [Instant input mode] option in [TOOLS]-[Options]-[Common Editor] and selecting [TOOLS]-[Options]-[LD]-[Advanced]-[Hold Cursors].

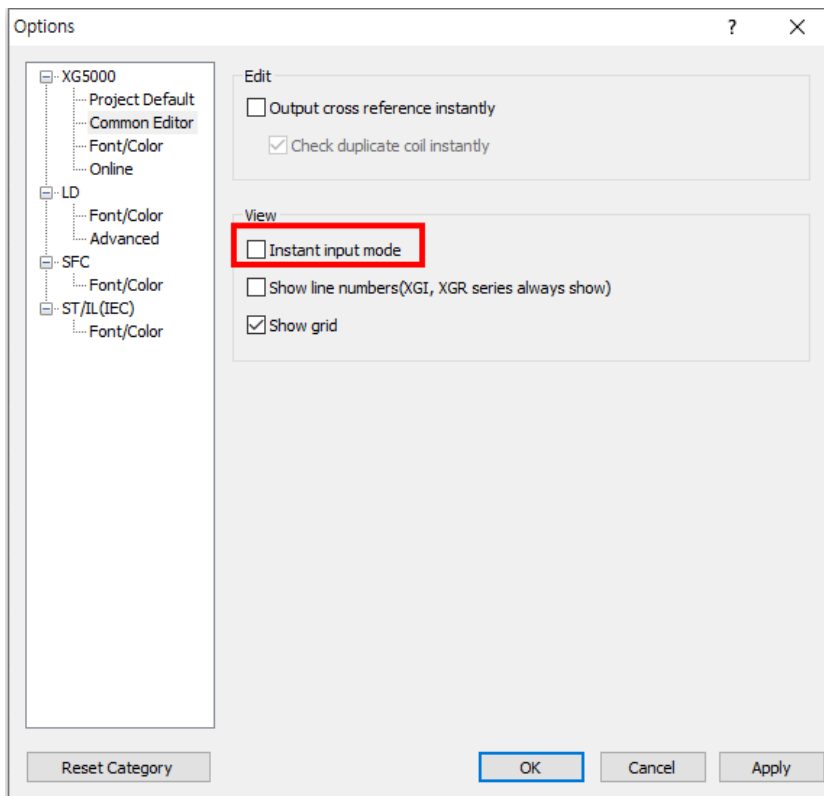

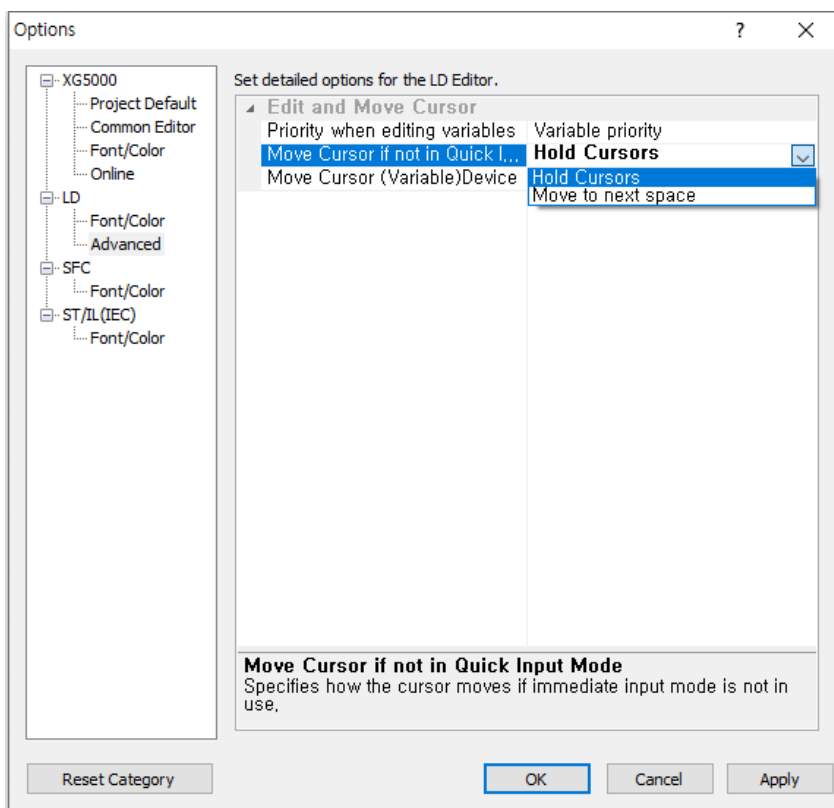

When the F3 key is pressed, the contact is added and the cursor maintains the position where the contact was added.



When you press F3 again, the contact is inserted at the next position and the cursor moves as well.



For coils, clicking F9 adds the coil and the cursor stays in place.

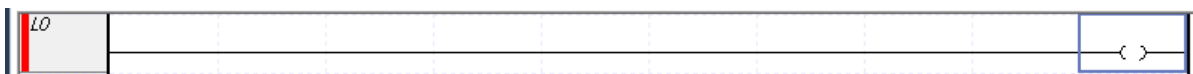

Clicking F9 again adds a coil to the next line and moves the cursor.

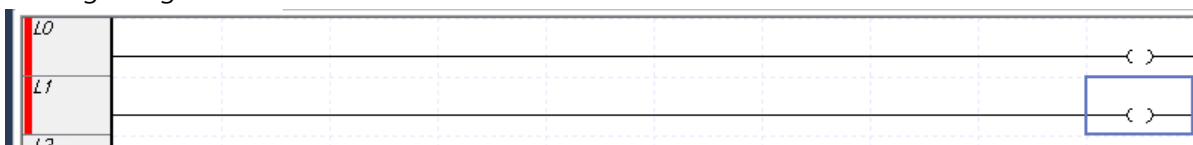

(23) Hold cursor function when inputting instruction operand in LD editor

The [TOOLS] – [Option] – [LD] – [Advanced] – [Move Cursor (Variable) Device] must be set to [Hold Cursors].

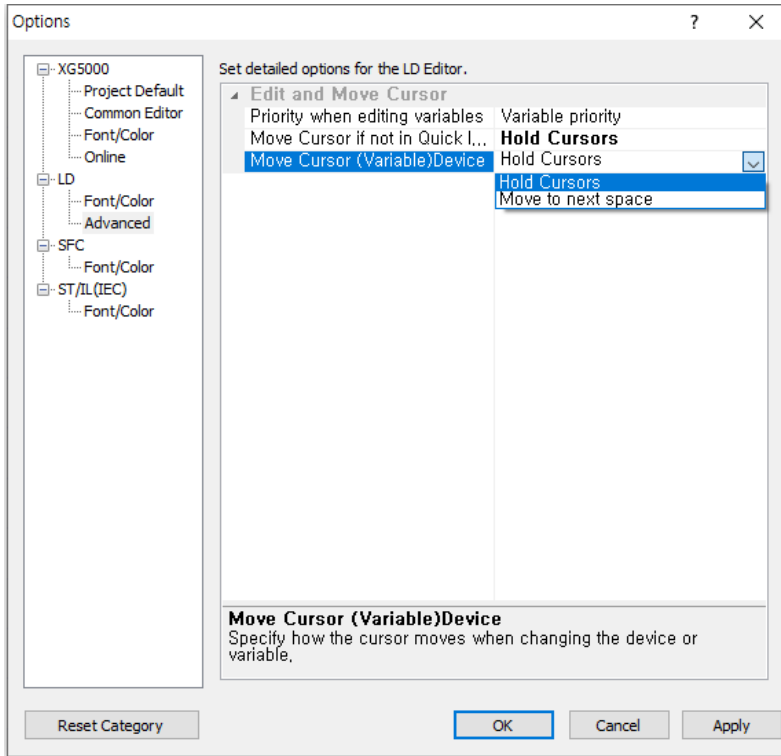

If you place the cursor on the operand of the instruction and click Enter, the variable input dialog box is displayed.

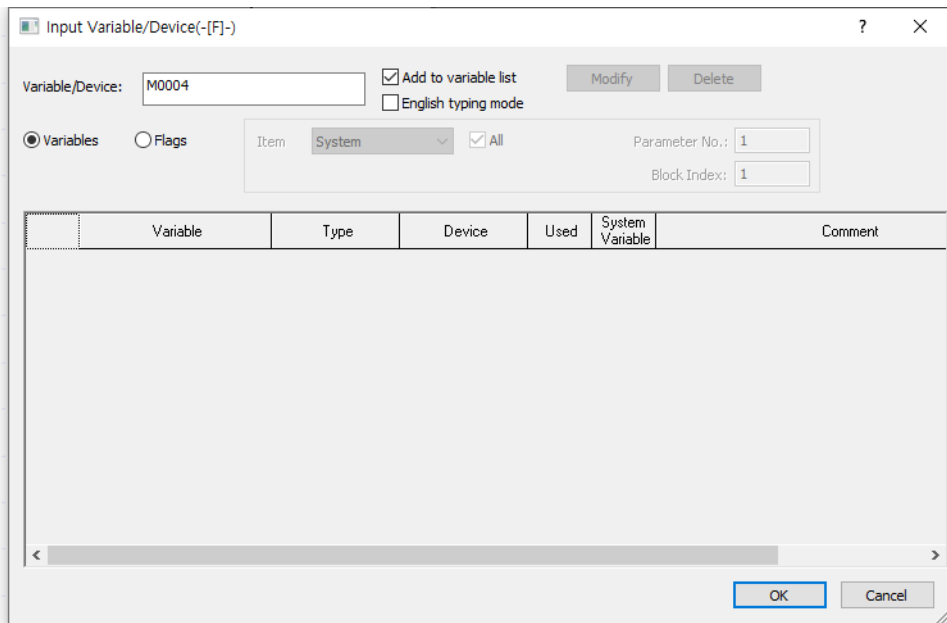
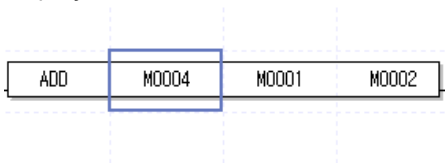

If you enter a variable and click [OK], the cursor remains in place without moving.

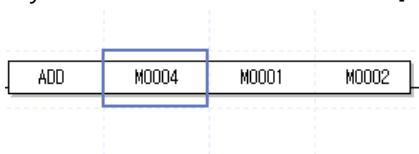

(24) In case of paste operation related to variable, blank line is automatically added if it is the last line

If you execute Paste Variable while the number of lines of data equals or exceeds the number of lines existing in the current window, a blank line is added after the last line of copied data. As shown in the example below, after pasting, you can immediately continue working on variables.

[Steps]

1. Copy data

	Variable Kind	Variable	Type	Address	Initial Value	Retain	Used	EIP/OPC UA	HMI	Comment
1	VAR_GLOBAL	aa	BOOL			<input type="checkbox"/>	<input type="checkbox"/>	<input type="checkbox"/>	<input type="checkbox"/>	
2	VAR_GLOBAL	bb	BOOL			<input type="checkbox"/>	<input type="checkbox"/>	<input type="checkbox"/>	<input type="checkbox"/>	
3	VAR_GLOBAL	cc	BOOL			<input type="checkbox"/>	<input type="checkbox"/>	<input type="checkbox"/>	<input type="checkbox"/>	
4						<input type="checkbox"/>	<input type="checkbox"/>	<input type="checkbox"/>	<input type="checkbox"/>	

2. Select area to paste the copied data.

	Variable Kind	Variable	Type	Address	Initial Value	Retain	Used	EIP/OPC UA	HMI	Comment
1	VAR	abs	BOOL			<input type="checkbox"/>	<input type="checkbox"/>	<input type="checkbox"/>	<input type="checkbox"/>	
2						<input type="checkbox"/>	<input type="checkbox"/>	<input type="checkbox"/>	<input type="checkbox"/>	

3. Operation can be performed immediately following the blank line (line 5) added after pasting

	Variable Kind	Variable	Type	Address	Initial Value	Retain	Used	EIP/OPC UA	HMI	Comment
1	VAR	abs	BOOL			<input type="checkbox"/>	<input type="checkbox"/>	<input type="checkbox"/>	<input type="checkbox"/>	
2	VAR_EXTERNAL	aa	BOOL			<input type="checkbox"/>	<input type="checkbox"/>	<input type="checkbox"/>	<input type="checkbox"/>	
3	VAR_EXTERNAL	bb	BOOL			<input type="checkbox"/>	<input type="checkbox"/>	<input type="checkbox"/>	<input type="checkbox"/>	
4	VAR_EXTERNAL	cc	BOOL			<input type="checkbox"/>	<input type="checkbox"/>	<input type="checkbox"/>	<input type="checkbox"/>	
5						<input type="checkbox"/>	<input type="checkbox"/>	<input type="checkbox"/>	<input type="checkbox"/>	

(25) Improved the [Compare with PLC] function

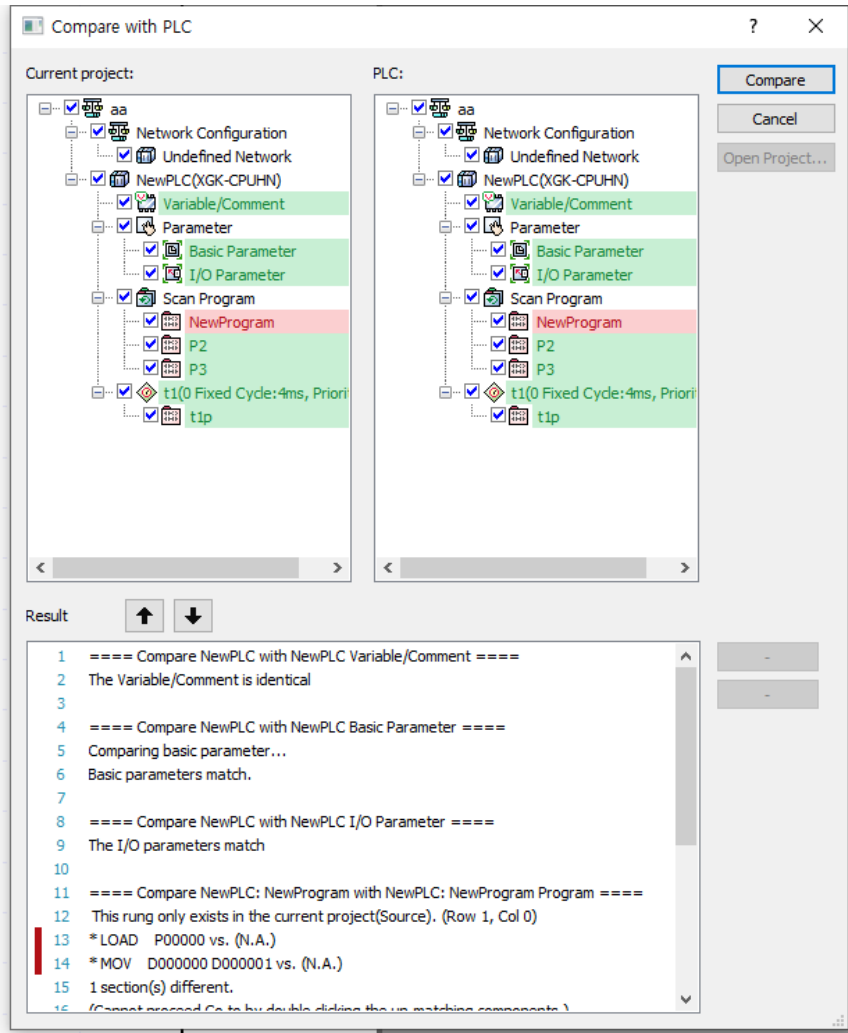

- The contents of the comparison result have been changed from the [Result] window to the inside of the [Compare with PLC] window.
- You can perform [Compare] continuously in the [Compare with PLC] window.
- The user selected items to be compared are highlighted so that they can be understood more clearly.
- Visualizes and provides results for the selected comparison item.
- You can find out different parts of [Result] more quickly.
- You can search by the selected item with the arrow buttons of [Result].
- The window size can now be adjusted.
- [Compare with PLC] function (algorithm) has been enhanced.

(26) Improved the Weighted Average(Filter) function in XGF-AD16A module

Separated weighted average (filter) setting function of analog input module XGF-AD16A.

Parameter	CH 0	CH 1	CH 2	CH 3	CH 4	CH 5	CH 6	CH 7
<input type="checkbox"/> Operation Channel	Disable	Disable	Disable	Disable	Disable	Disable	Disable	Disable
<input type="checkbox"/> Input Range Setting	4~20mA	4~20mA	4~20mA	4~20mA	4~20mA	4~20mA	4~20mA	4~20mA
Output Data Type	0~16000	0~16000	0~16000	0~16000	0~16000	0~16000	0~16000	0~16000
<input type="checkbox"/> Filter Processing	Disable	Disable	Disable	Disable	Disable	Disable	Disable	Disable
Filter Constant	1	1	1	1	1	1	1	1
<input type="checkbox"/> Average Processing	Sampling	Sampling	Sampling	Sampling	Sampling	Sampling	Sampling	Sampling
Average value	0	0	0	0	0	0	0	0
<input type="checkbox"/> Hold Last Value	Disable	Disable	Disable	Disable	Disable	Disable	Disable	Disable

(27) Added new instruction

- SETPORT/GETPORT (XBC type)
- GROUP_FILL, GROUP_ROTATE, GROUP_SHIFT, GROUP_FIND, GROUP_MOVE (XGI-CPUUN type)

Please refer to the instruction manual.

(28) Positive Transition-sensing, Negative Transition-sensing

A function to sense the up/down pulse for the previous state has been added.

Supported models: All XGI models excluding XGB (IEC), all XMC models

The position available in LD program is the same as "reverse contact".

Menu [Edit]-[Tools]-[Positive Transition-sensing, Negative Transition-sensing]

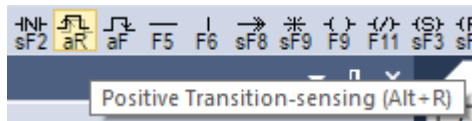
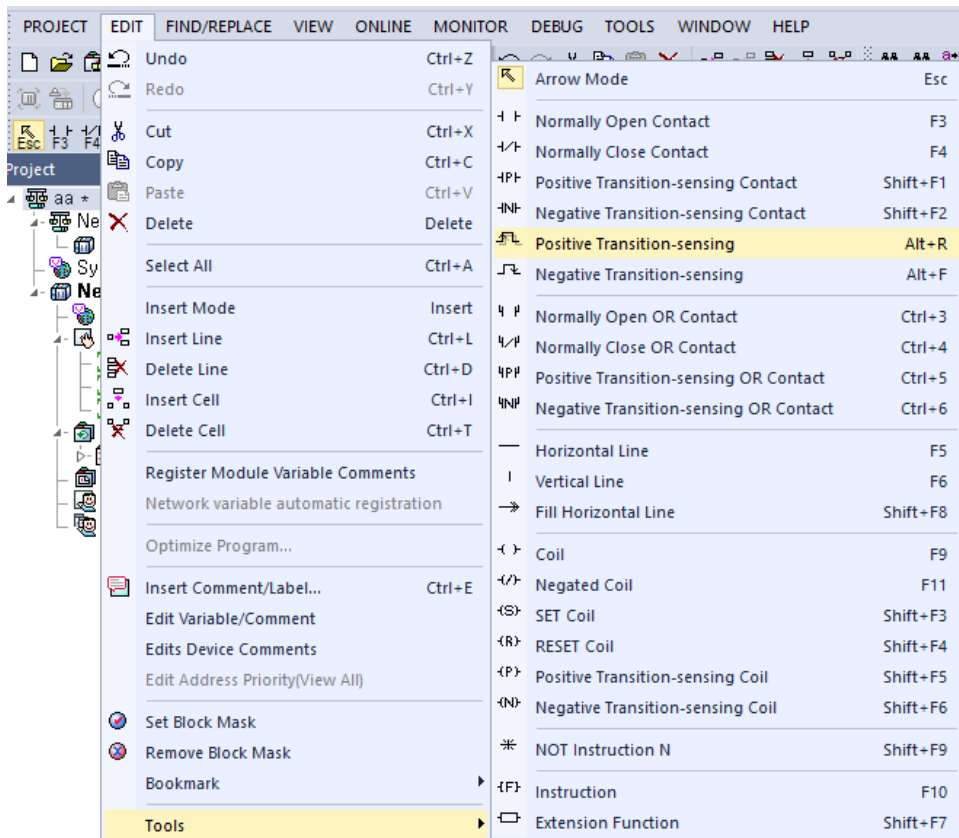

(29) Added device function used for smart extension

Device functions used in sub-items related to smart expansion have been added. The items to which the used device function is added are as follows.

- Allocate Input/Output Variables
- Allocate Diagnostic Variables
- Advanced Settings
- Sets EIP Server

(30) Improved the Open Device Monitor File function

Improved the function to save the data even if the Saved Device Monitor file's PLC type is different.

2. Error Correction

(1) Fixed an error with XGK output comment upload(XG5000 V4.5 applied)

When opening from PLC, a problem in which the rung comment and the collision phenomenon occurred and displayed incorrectly has been fixed.

(2) Fixed an error with memory reference of XGK Auto-allocation variable

Fixed an issue where items declared as variables in the XGK auto-allocation project were not displayed in the memory reference.

(3) Fixed an issue with the EtherNet/IP tag mismatch problem in XGB IEC model

Fixed EtherNet/IP tag mismatch problem in IEC type models such as XGB-XECH and XEMH.

(4) Fixed the execution error (Windows XP)

A problem that does not run normally on Windows XP has been fixed.

(5) Fixed the EDS file revision error

An error that occurred when processing EDS files with different revision information has been corrected. When other files are used in an existing saved project, there is an error that the detailed EIP settings do not work normally, so when the revision information is different, a warning message is displayed in the user message and result window.

(6) Fixed an error with STRING_BYTE instruction in XMC PLC

Fixed an error where the output value was out of the range of the array.

(7) Fixed an error with Online Edit

Fixed an error that occurred when attempting to online edit an edited program after online force edit. As for XECU, the issue with elongated scan time after online editing from an older version has been fixed.

(8) Fixed an error with Compare function's operand

Fixed an error where the operand of Compare function was not editable.

(9) Fixed an error that occurred when opening a xgp file created from XG5000 V3.x

Fixed an error that failed to open project files from previous versions.

(10) Fixed an error with abnormal termination

When right clicking on Variable/Comment, When Program Checking, fixed an error with abnormal termination.

(11) Error with inserting device comment

Fixed an error with inserting device in the device comment section.

(12) Error with showing system variable

Fixed an issue with the wrong color representation with used Cnet P2P variable device.

(13) Fixed an error with inserting invalid EDS RPI value

Fixed an issue when inserting RPI values in microsecond.

(14) Fixed an error with inserting comments

Fixed an error with the comment insert menu.

(15) Error in string constant

Fixed an error in compiling string constant in User Function Block.

(16) Error in parsing nConfigurator

Fixed an error in parsing slave module in nConfigurator.

(17) Error in canceling Run Edit

Fixed an error in canceling Run Edit (Improper uploading source program stored the PLC).

(18) Fixed an error during Run Edit

Fixed an error where it failed to identify program difference, when opening a project in Run Edit.

3. XG-PM

(1) Added the save interface of SDO Parameter

[SDO parameter save] is a function to save to the slave after modifying the parameters on the [SDO parameter] screen. It was a function to save the SDO (servo) parameters of the connected slave (individual axis or all axes) and the axis designated in [Command axis]. In addition to the entire and slaves, we have added a function to select the storage target for each slave by reflecting the user's requirement to save the parameters for the selected multiple slaves.

(2) Added the XGF-M32E module initialization history in module history

Added module initialization history to reinforce customer data management history. Among the existing module history, you can check whether the module is initialized or not in the system history as follows.

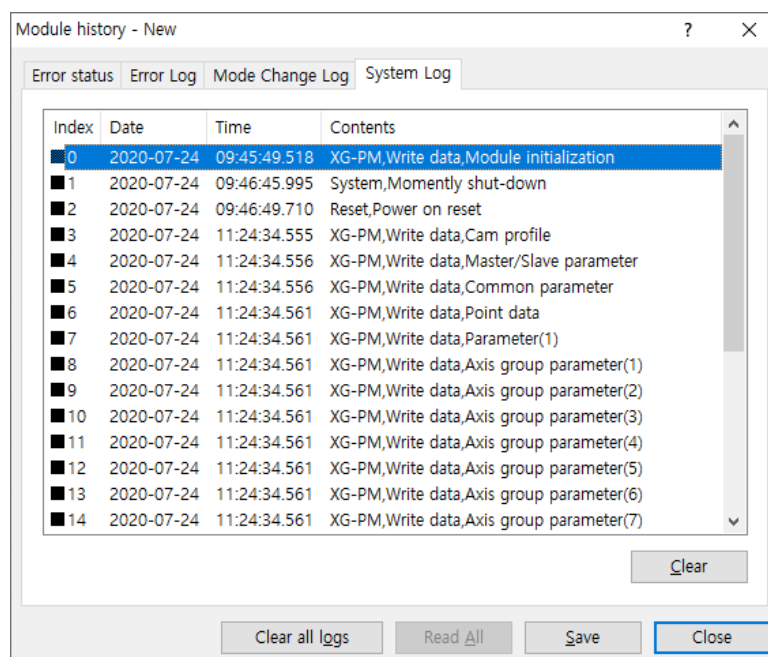

(3) Added the re-allocate Auto-allocated Variable

Added the function to re-allocate the address of auto-allocated variables.

(4) Improved program monitoring

Improved monitoring when multiple windows are open.

(5) Improved Write SDO Parameter

Improved the problem with EEPROM timeout when writing SDO parameter while connected to the servo.

(6) Improved UDFB of XGF-M32E

Improved the problem that UDFB stack area error occurs when the scan time is prolonged when using UDFB in periodic task.

■ ReleaseNote - XG5000 V4.50

1. Improvements and additions

(1) Added XGK multiple PB(program) online edit feature

Multiple PB online edit feature has been added to the high-performance XGK(XGK-CPUSN/CPUHN/CPUUN) CPUs. Now the user can access into two or more online edit mode, but cannot simultaneously write to the PLC. The following O/S version is required to use multiple PB(program) online edit feature.

- XGK-CPUSN/CPUHN/CPUUN O/S: V1.4 or later version

(2) Added online force edit feature

Online edit is now available, even when the PLC project and XG5000 project is different. Online force edit is only supported in PLCs that support Multiple PB.

- High-performance XGK CPU(excluding auto-allocation project) and IEC series(XGI, XGR, XEC)
- XGK-CPUSN/CPUHN/CPUUN O/S: V1.4 or later version

[Description]

Menu – [Online] – [Online Force Edit]

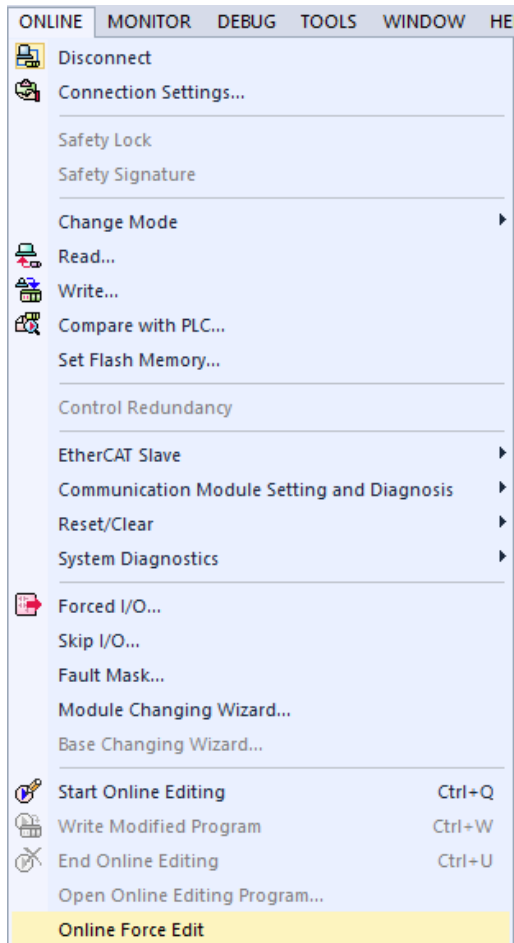

- The edited program is merged with the online PLC program when using online force edit feature. For more information about online force edit please refer to the product manual.

XGK Project

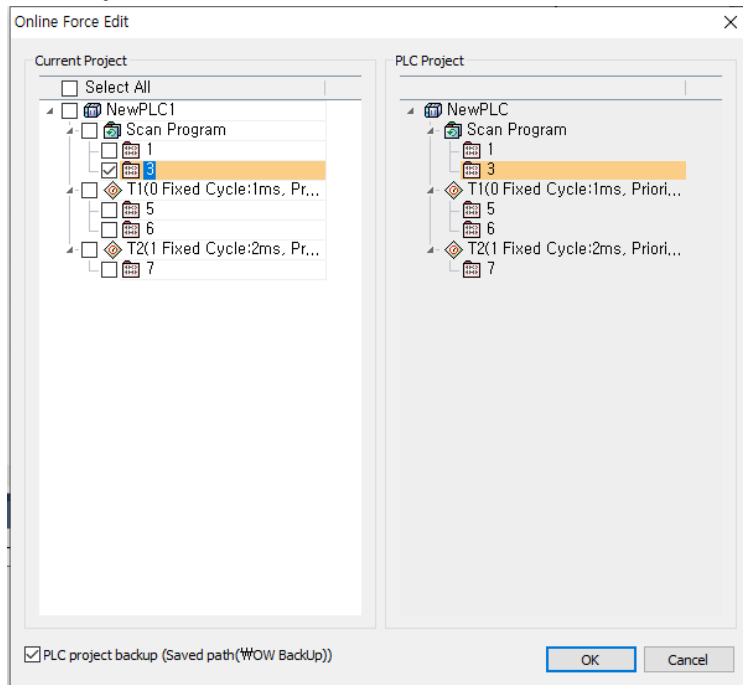

XGI Project

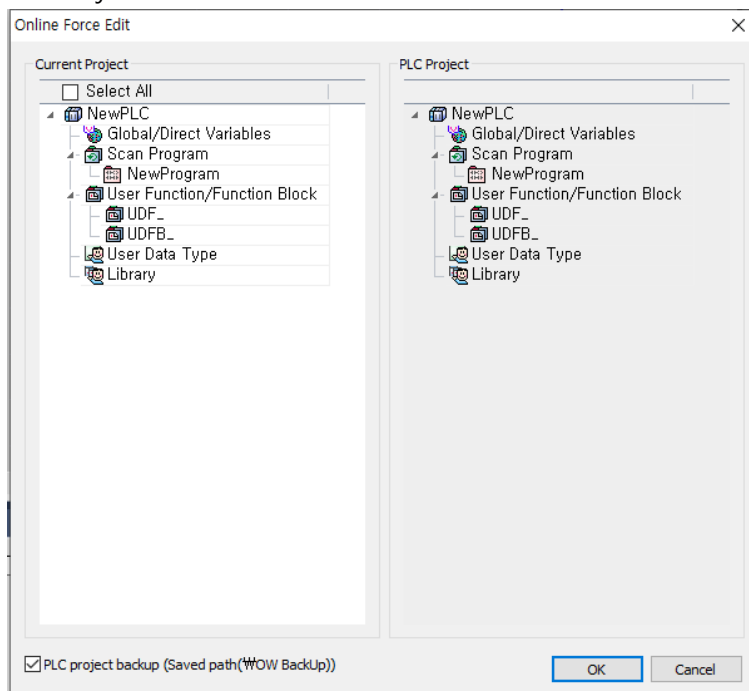

(3) Added find coil feature

If the selected device is a contact, then it finds the device's coil. If the selected device is a coil, then it finds the device's contact.

- Menu – [Find/Replace] – [Find Contact/Coil]

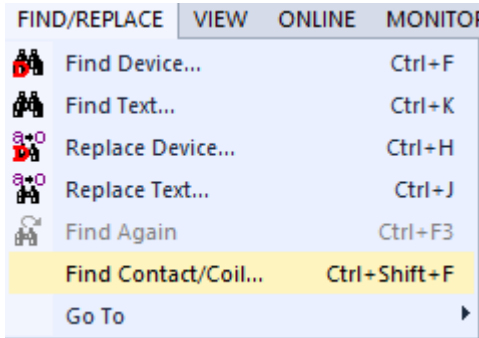

- Default Shortcut Key: Ctrl + Shift + F

- LD Editor 동작

■ Start by selecting a cell without a contact or a coil.

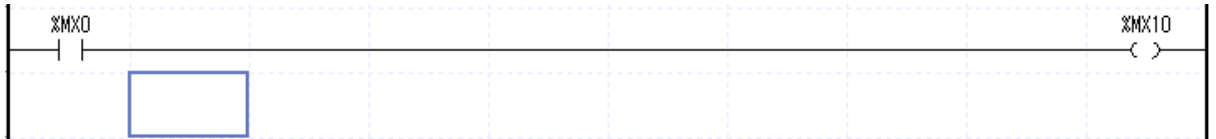

-> Find Device window is activated and the "All Contacts" will be selected.

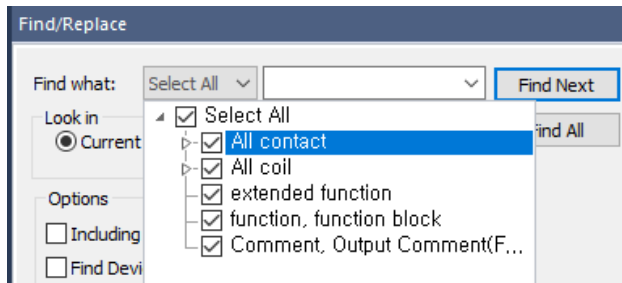

■ Proceeds the process after selecting coil. (Searches for the contact related to the selected coil)

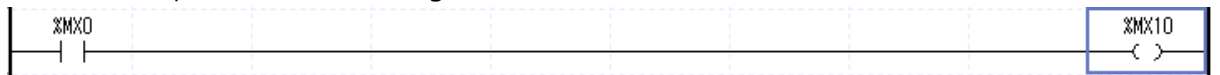

-> Text changes to "All Contacts" and the selected device value is inserted to the edit box. Then performs "Find Next".

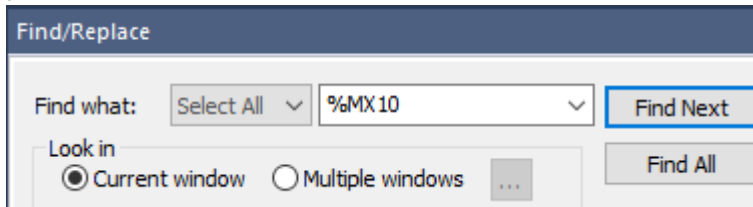

■ Operate after selecting a contact(find the coil related to the contact)



-> Text changes to "All Coils" and the selected device value is inserted to the edit box. Then performs "Find Next".

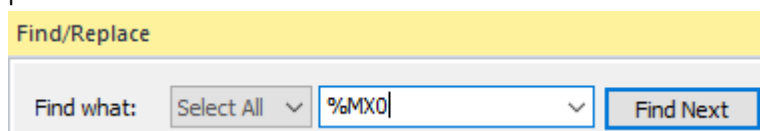

(4) Improvement requested for selecting variable type when inserting variable

Improvements were made for the inconveniences when inserting global variables again in the XGI editor by opening the "Local Variables" window on the initial screen. When the Select Variables dialog opens, the previously inserted variable type windows opens.

(5) Added variable view options – View All

Added a view option that displays everything including variables/devices/Comments.

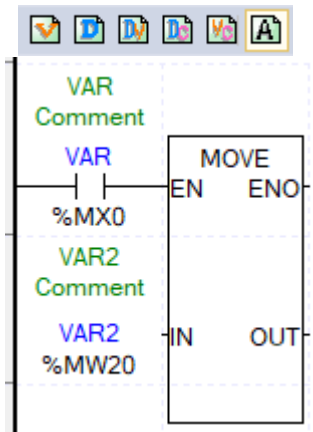

(6) Improved the way Z Index is displayed in cross reference

Made improvements in cross reference, so that it displays the used memory as Z Index.

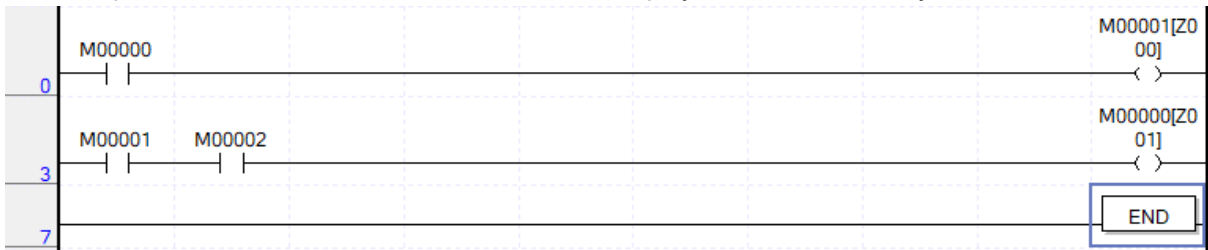

Cross Reference							
Device Name	Variable	IN/OUT	PLC	Program	Position	Comment	Information
M00000		INPUT	NewPLC1	3	Row 0, Col...		- -
M00000[Z001]		OUTPUT	NewPLC1	3	Row 1, Col...		-(-)
M00001		INPUT	NewPLC1	3	Row 1, Col...		- -
M00001[Z000]		OUTPUT	NewPLC1	3	Row 0, Col...		-(-)

(7) Show unsigned on DMOV function's operand

[Steps]

- I. [Project] – [New Project] to open the New Project dialog, then select XGK from the CPU Series and any of the CPU type. Next click the [OK] button.

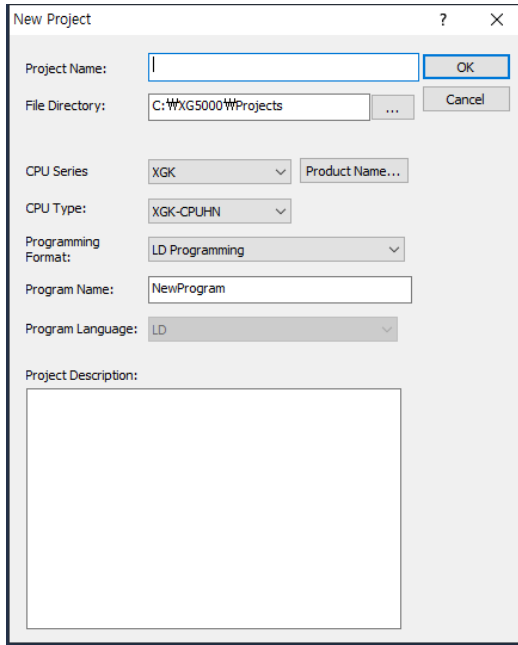

- II. Add the following contacts and DMOV function with the negative parameter in the LD editor.

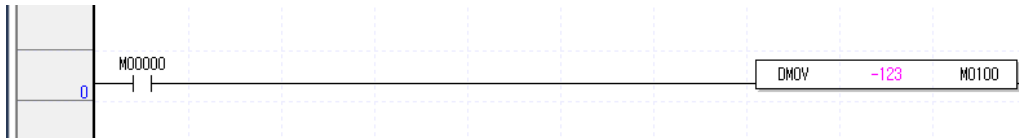

- III. Click the [Start/Stop Simulator] icon in the project toolbar, and then click the [OK] button.

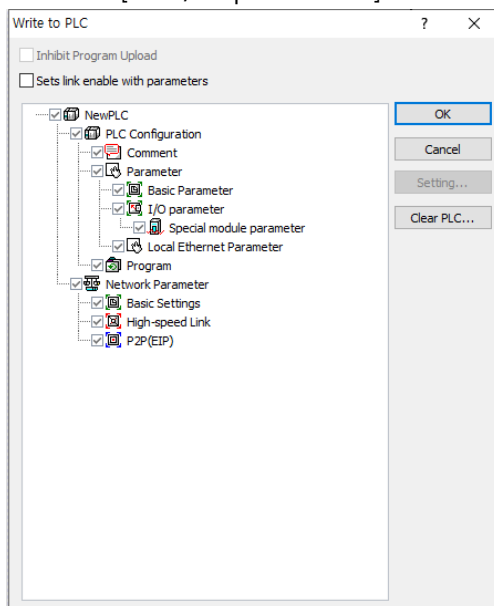

- IV. After the simulation is initialized, double click the contact and click [OK] after checking that ON is selected.

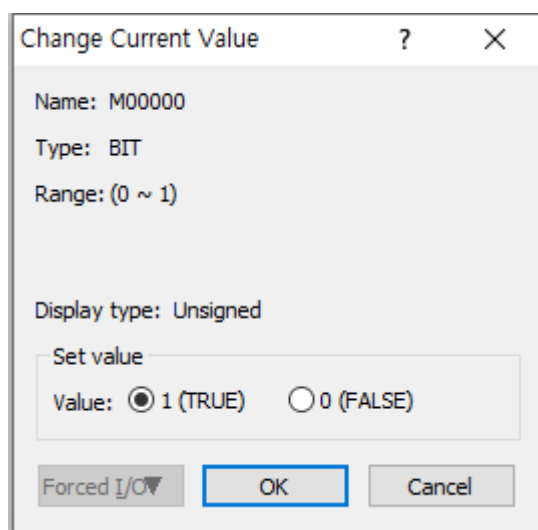

- V. Check DMOV function's second parameter value.



- VI. Select [Tools]-[Options] in the Project menu.

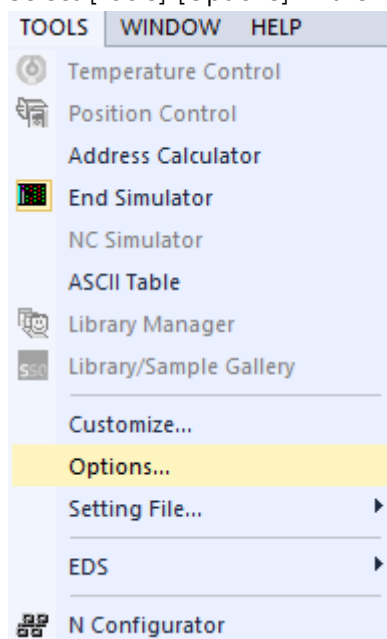

- VII. In the XG5000 – Online field, select [As instruction (all languages except for ST)] radio button and check the [MOV Series Command Displayed in Signed Decimal (XGK)] check box, then click [OK].

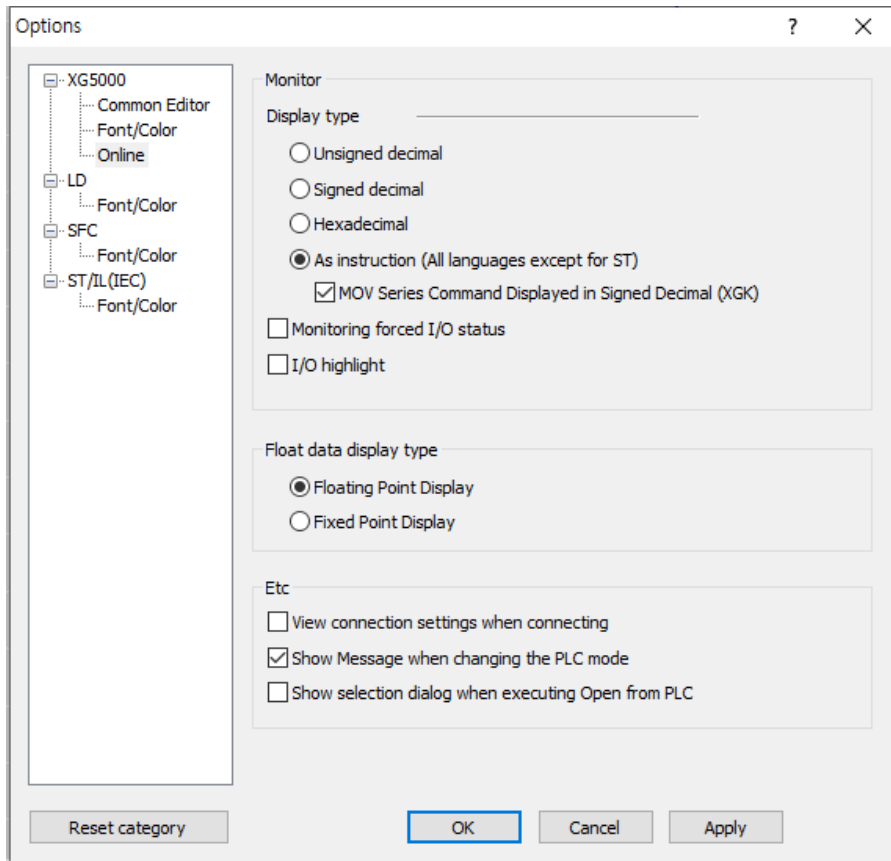

VIII. Check that DMOV function's parameter is now displayed in integers with sign.

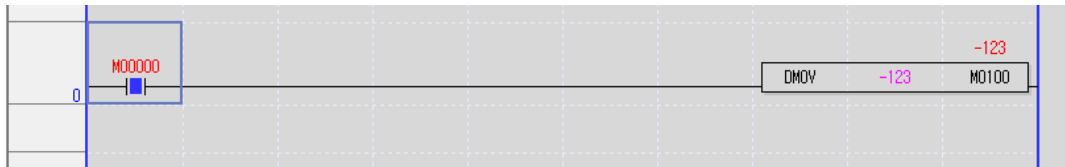

(8) Function block parameter can be omitted in LD

Added the feature to omit input parameters for function blocks. The omitted parameter value will act as 0. However, array and user data type cannot be omitted.

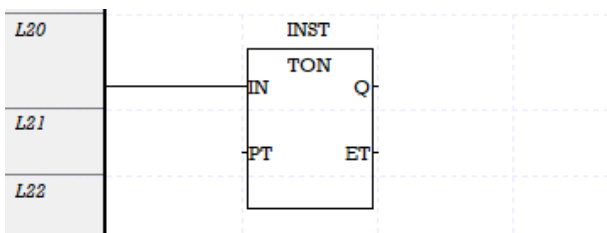
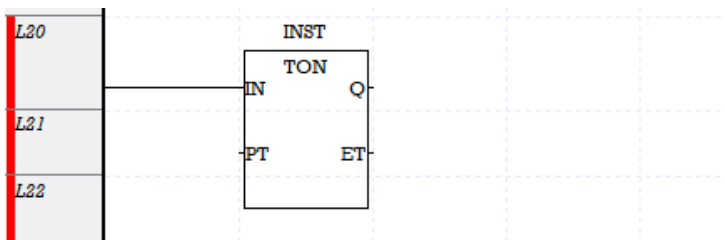

The settings on omitting input parameter can be found at Program Check window.

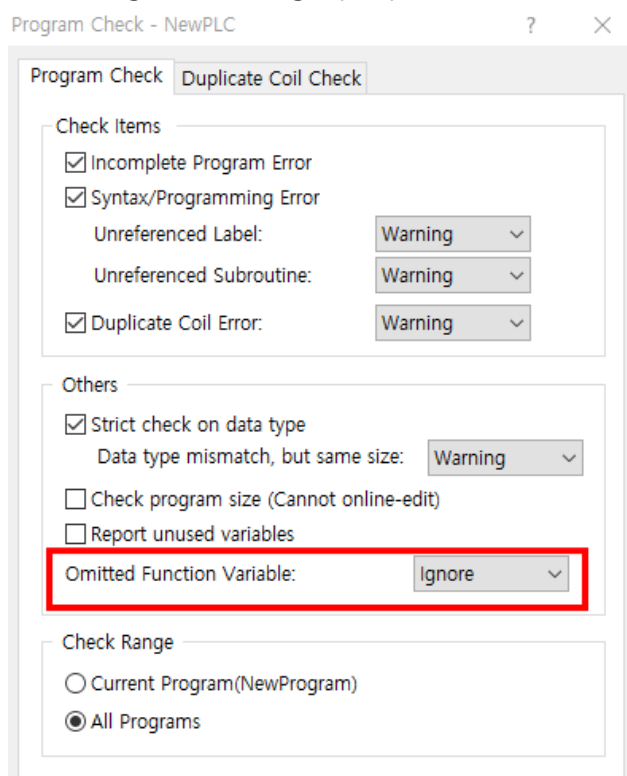

(9) Added monitoring(BOOL type I/O variable) function block instance feature

Added monitoring feature for function blocks with BOOL type input/output. If the instance value is 1, then the power flow color will be displayed.

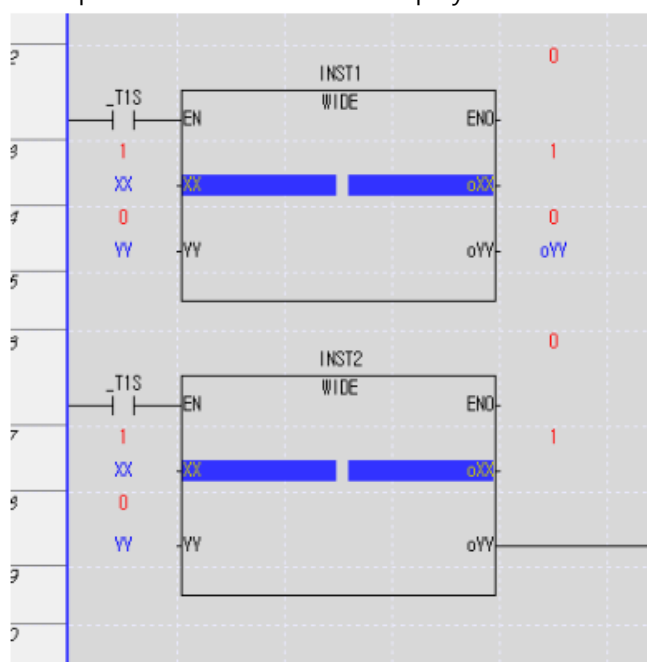

(10) Changed the number of parameters for user function and function block

Changed the number of I/O parameters for user function and function block from 64 to 100. (EN, ENO, Return variables included)

(11) Find block mask feature

Added the feature to search for blocked mask in ladder programs.

[Steps]

Menu [Find/Replace]-[Find]-[Block Mask].

Searched block mask will be shown on the Result window. Double click it to go to that location.

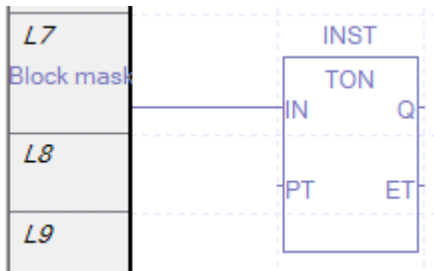
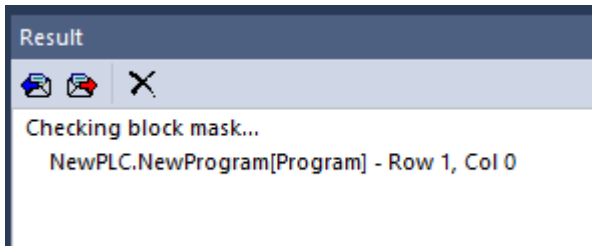

(12) Added a new feature in Variable list[Add line]

With the new feature, a new line can be added right below the selected cell.

[Step]

- ① Activate variable window
- ② Menu bar [Edit] – [Add Line] or Tool bar [Edit] – [Add Line]
- ③ Multiple lines will be added if multiple lines are selected.
- ④ The original function [Insert Line] can also be used when needed to increase usability and efficiency.

[Note]

- [Insert Line]: Insert a line in between the previous line and the current line.
- [Add Line]: Add a line after the current line.

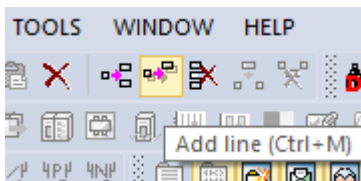

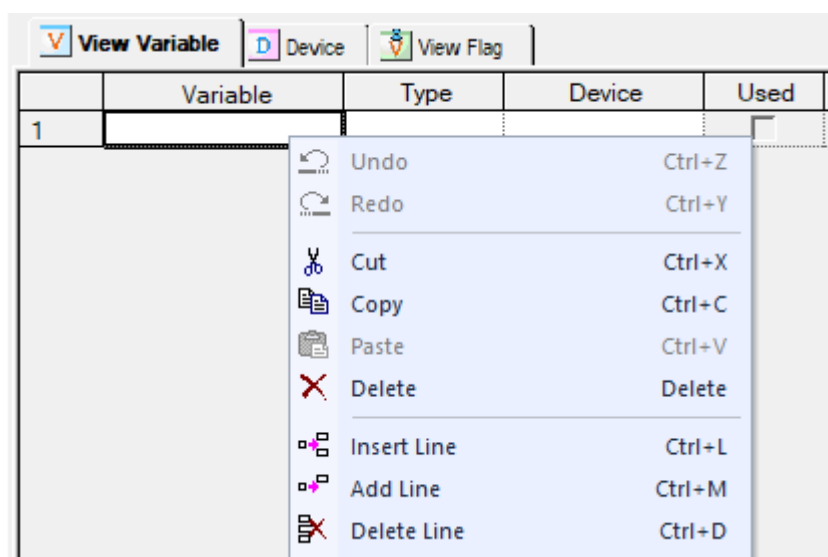

Context Menu

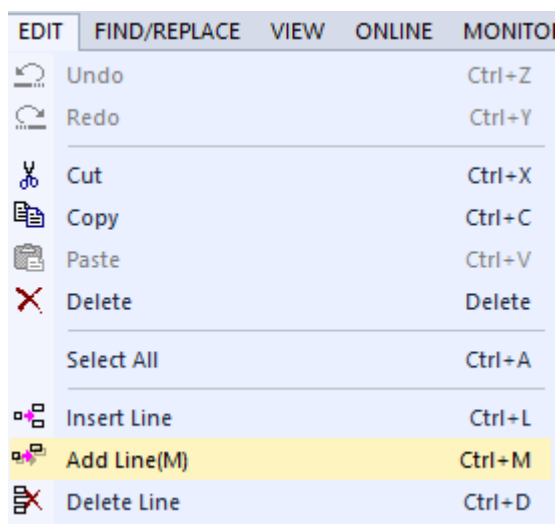

(13) Improved the feature [Paste] in variable list

Line will be automatically added when variables are pasted from programs like Excel.

The improvement can also be seen when duplicate variables or multiple data are pasted. This improvement will make enhance user usability and experience.

2									
3		VAR_GLOBAL	AA	BOOL					
4		VAR_GLOBAL	BB	BOOL					
5		VAR_GLOBAL	CC	BOOL					
6		VAR_GLOBAL	DD	BOOL					
7									

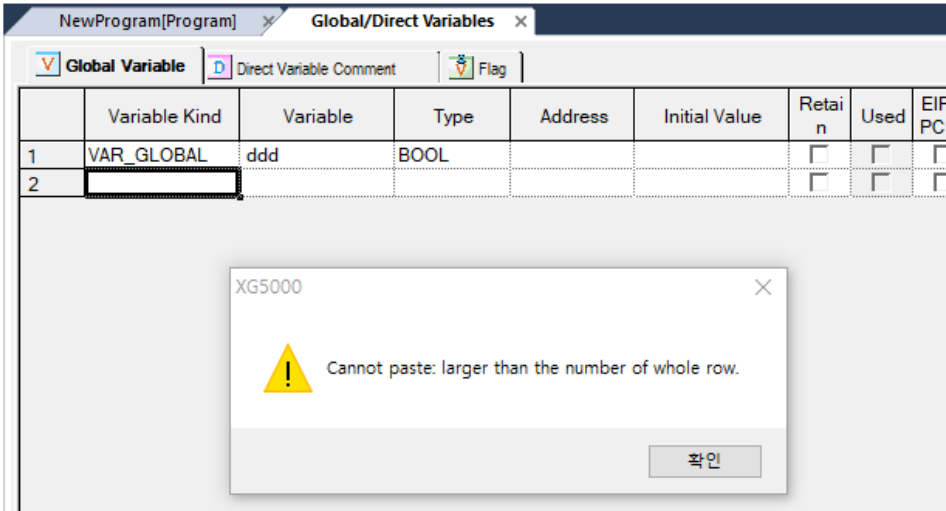

Problem before improvement (Other program data -> Paste in to XG5000)

(14) Added 32 Bit Index function (Z Index Register)

32 Bit index function has been added for high-performance XGK(XGK-CPUHN, XGK-CPUSN, XGK-CPUUN) CPUs. 32 Bit Index can be set in the range of Z004 ~ Z254. This feature can be found in Basic Parameter dialog.

- XGK-CPUSN/CPUHN/CPUUN O/S: V1.4 or later version

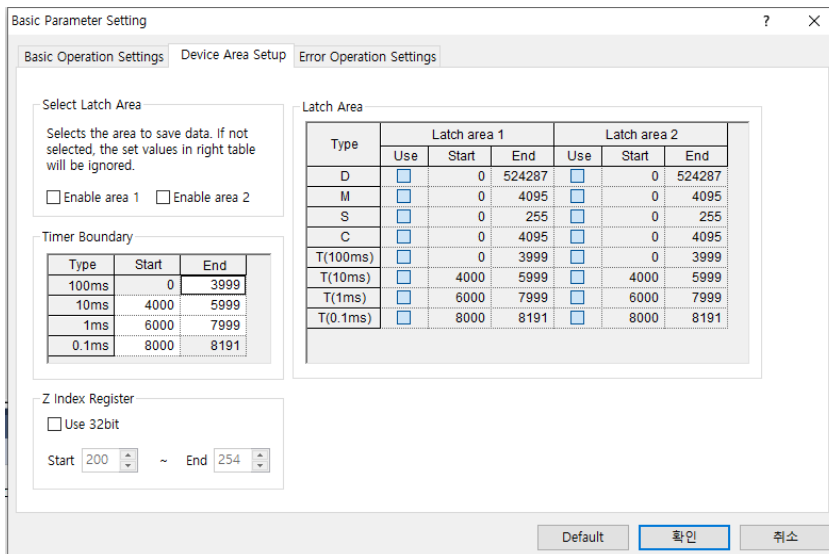

(15) Added SSQ library linkage feature

Added "Library/Sample Gallery" feature to download XG5000 engineering samples in conjunction with Solution Square (<https://ssq.lselectric.co.kr>), LS ELECTRIC's engineering knowledgebase website.

Menu – [Tools] – Library/Sample Gallery

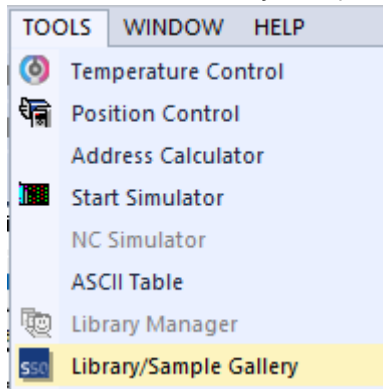

The sample files that's organized with Tags in the SSQ Library can be downloaded.

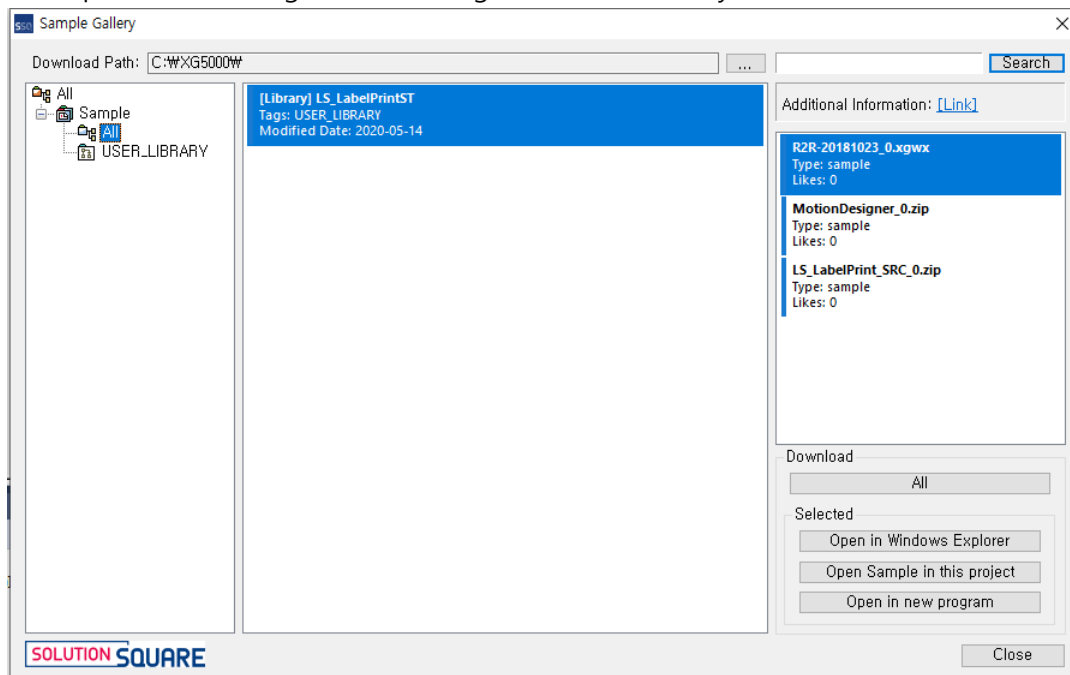

(16) Added project auto save feature

Project auto save feature has been added. If the project is not saved for the specified amount of time after editing the project, the project file will be temporarily saved in the auto save location.

[Step]

Menu [Tools]-[Options] then select XG5000.

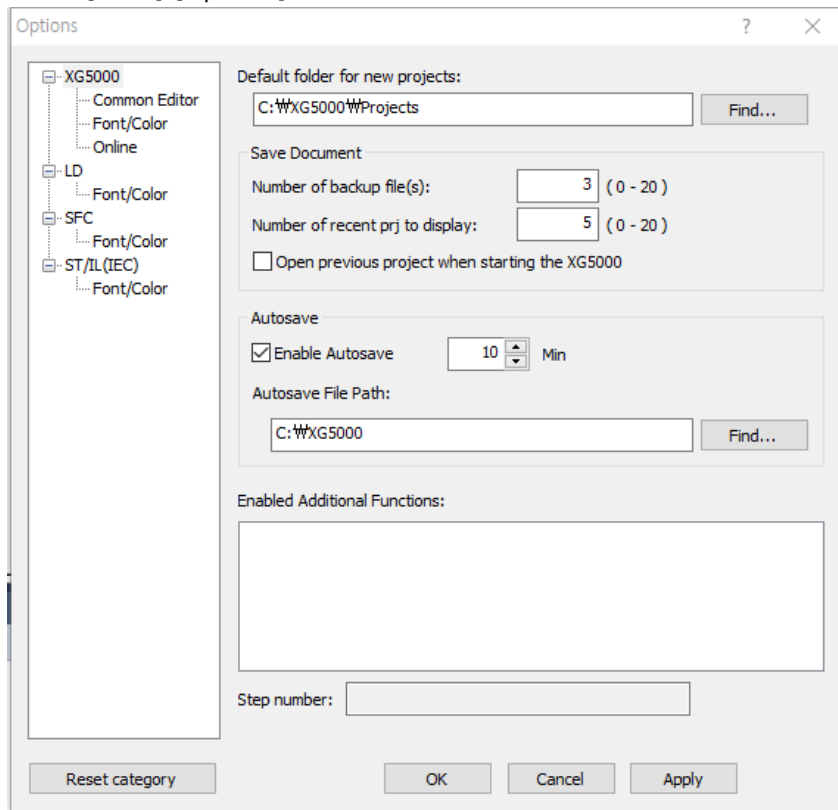

Enable Autosave: Select whether to enable auto save. You can add up to 1~60 minutes.

Autosave File Path: Specifies the location for the project file to be automatically saved.

(17) Improved XG5000 compare project feature

The existing project comparison feature has been improved as shown below. Further improvements will be carried out on the feature.

<Compare Project Example>

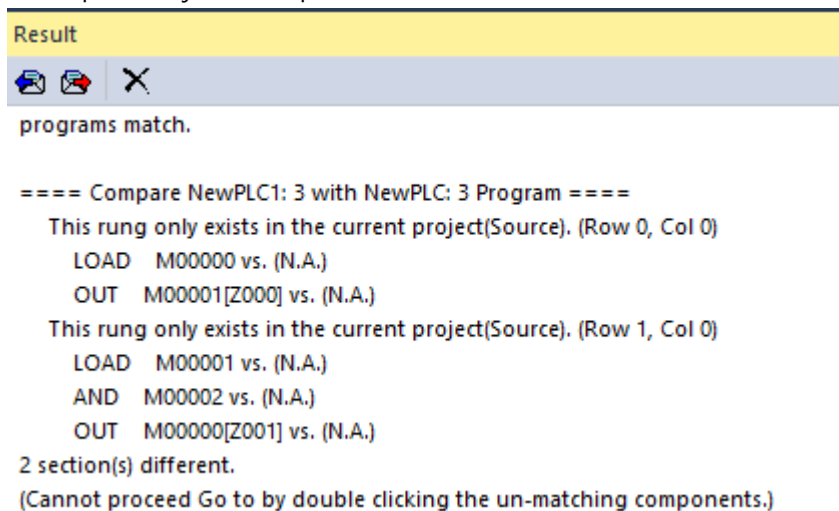

- Comment, block mask, function, variables, etc can be compared.
- [Result] By double clicking the different (*) component in the window, it can automatically locate to the window.
 - ✓ Ex) Finds the approximate location if the component only exists on one project.
- We have unified the project's display and operation between all PLC CPU series.

(18) Sort variables on Variable/Device input dialog

In the Variable/Device input dialog, double click on the header of the grid column to sort the variables. The feature has been modified to keep the dialog in alignment when reopened.

(19) Added variable edit feature in LD program

Select the variable to edit in the LD program, click [Edit Variable/Comment] menu, or use the shortcut key to open variable edit dialog.

- Global variable, local variable, direct variable, and direct variables with comment can be edited.
- Flag and induced type (Array, structure, function block)'s member variable is not provided.
- The feature is available for XGI, XGR, XGB(IEC), XGS, XMC CPU series.

(20) Added description for array types in user data type

This feature allows you to add a description of the array type members in the user data type.

If the user data type is used, then the default description will be displayed.

You can edit the description that has been set through the user data type settings dialog.

- The feature is available for XGI, XGR, XGB(IEC), XGS, XMC CPU series.

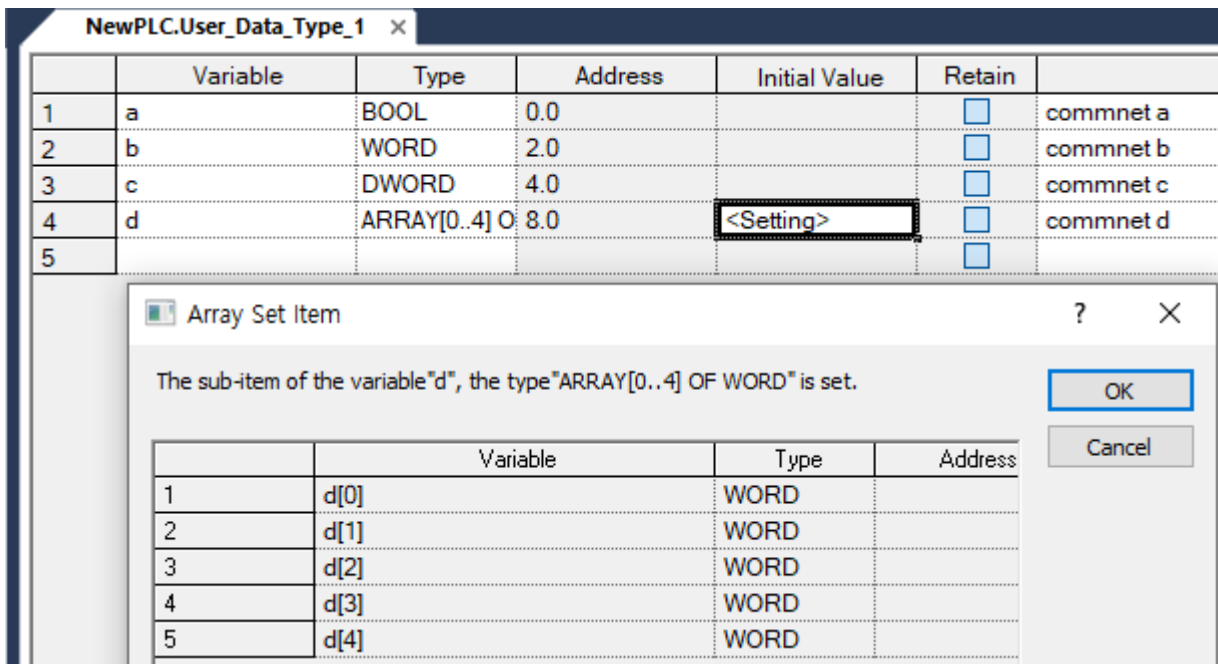

(21) Add to variable monitor feature

The feature register variables in the variable monitor window through the [Monitor] menu or the context menu's [Add to Variable Monitor], [Add to Current Variable Monitor].

The feature is available in the following windows: Variable/Comment, Global/Direct Variable, Local variable, Program(LD, SFC, ST, IL(IEC))

(22) Added M Area retain setting feature

In Basic Parameter dialog's [Retain Area Setup] tab, you can set the retain area groups in the M area. The group has been expanded from 1 to 4 groups.

XGI-CPUUN CPU O/S: V1.60 or later version (Feature will be available for XGI CPU and XGR CPU in the later version.)

XGI-CPUUN CPU O/S: In versions earlier than V1.60, please use one area.

(23) Added multiple input for function and function block feature in the LD program

If the input parameter type of function or function block is BOOL type, then a line or contact can be added in the input parameter for LD programs. This feature is available for XGI, XGR, XGB(IEC), XMC CPU series.

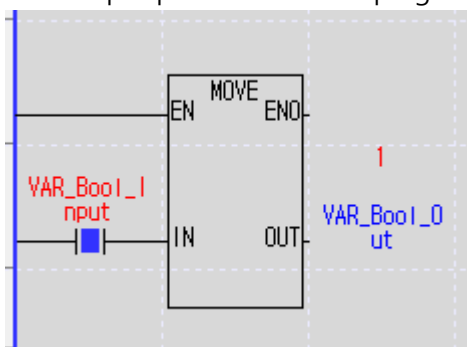

(24) Added function block instance array feature (XMC only)

Array type can be used in task programs when initializing function block's instance variable.

By using the FOR function as below, you can easily control multiple tasks easily.

This feature is not available for user function block programs.

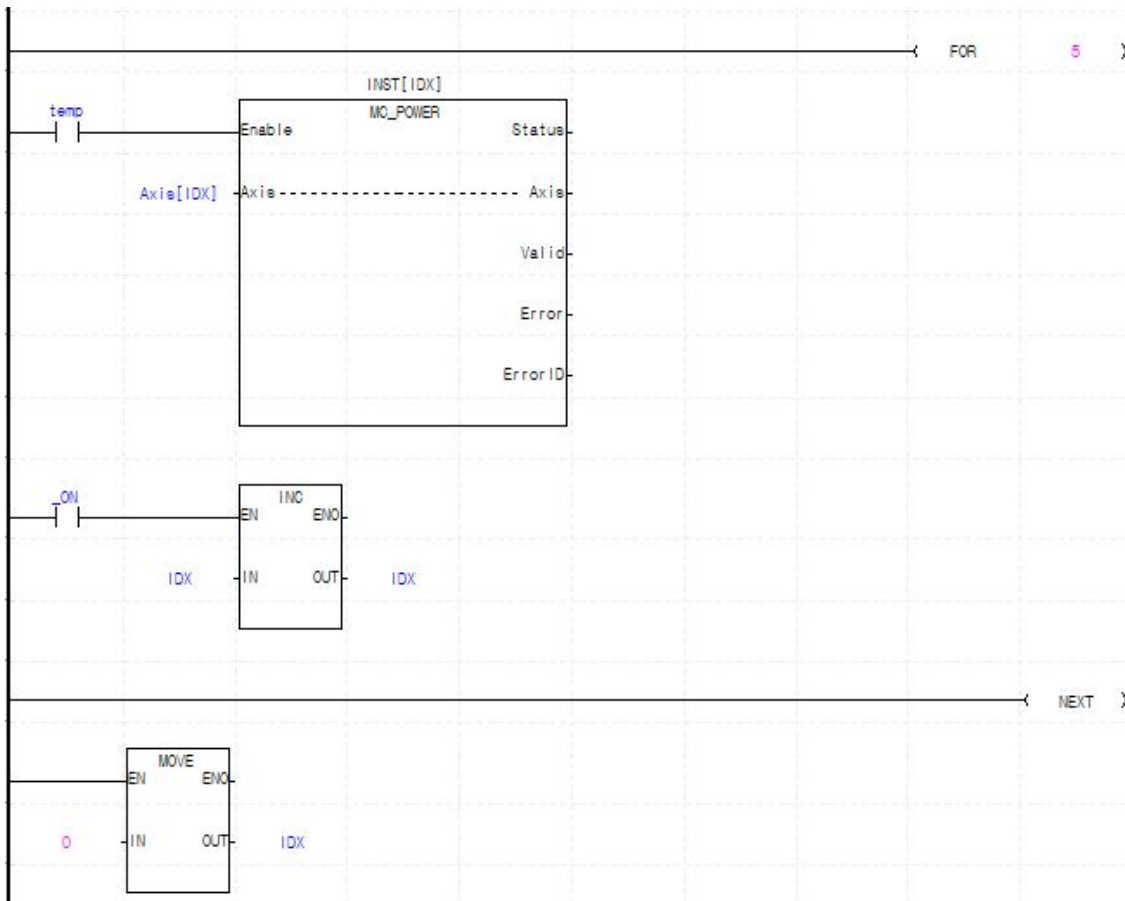

	변수 종류	변수	타입	메모리 할당	초기값	리테인	사용유무
1	VAR	Axis	ARRAY[0..4] OF UINT		<설정>	<input type="checkbox"/>	<input checked="" type="checkbox"/>
2	VAR	IDX	UINT			<input type="checkbox"/>	<input checked="" type="checkbox"/>
3	VAR	INST	ARRAY[0..4] OF MC_POWER			<input type="checkbox"/>	<input checked="" type="checkbox"/>
4	VAR	temp	BOOL			<input type="checkbox"/>	<input checked="" type="checkbox"/>

(25) Improved LD edit features

When adding function/function block, line and the position is automatically relocated.

<Current cursor location>

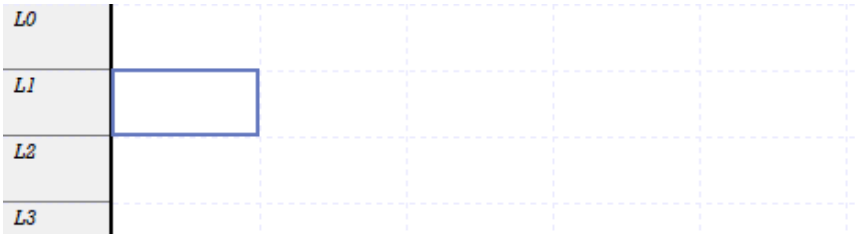

<Insert MOVE using F10 >

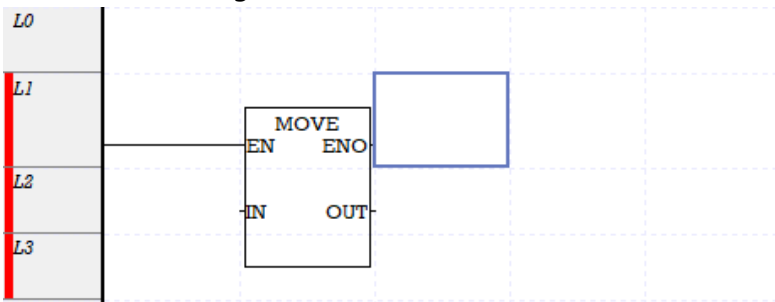

<Insert MOVE using F10 >

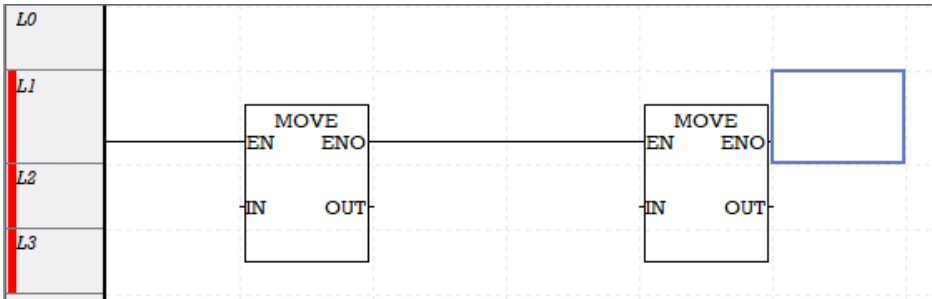

Contacts can be inserted when pasted (Insert Mode)

<Copying in Insert Mode>

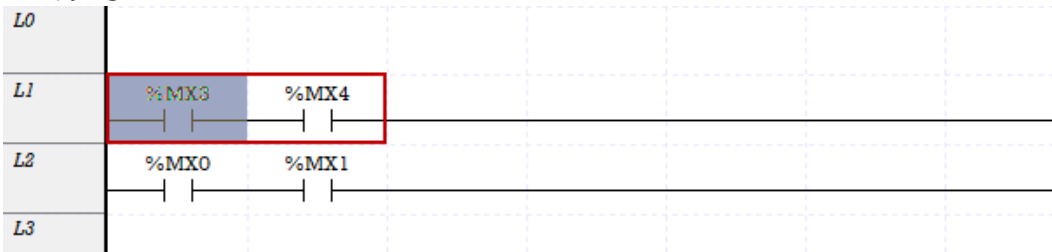

<Paste after moving the cursor>

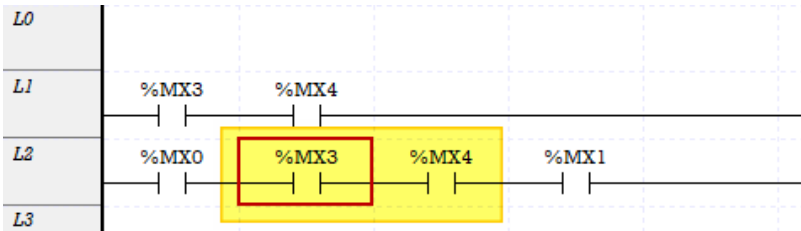

Automatically linking the line when deleting a contact(Insert Mode)

<Select area that will be deleted >

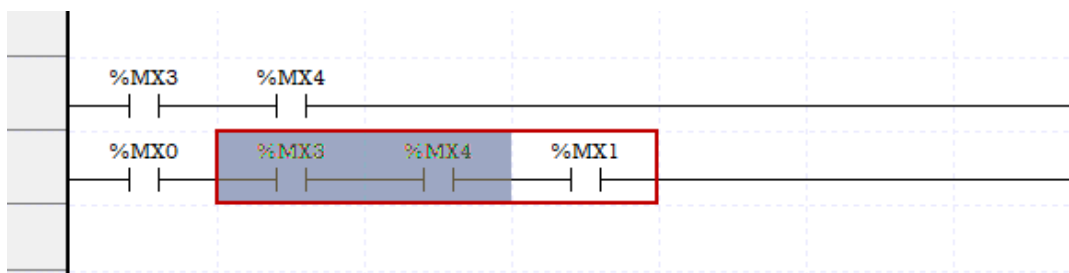

<Use the Del key to delete the contacts>

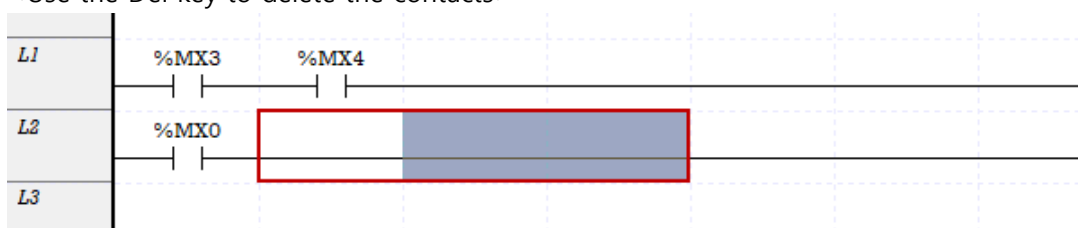

(26) Display variable size

Variable size is now displayed in LD tooltip. Size is valid after compilation.

The unit of BIT and NIBBLE types are BIT, and the unit of data types greater than BYTE type is BYTE.

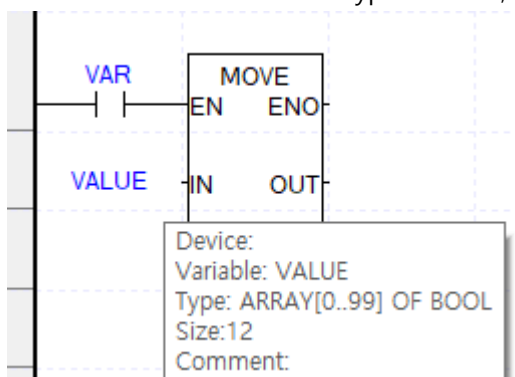

(27) Added Find Contact/coil feature

A new feature that finds and locates the coil that affects the contact, and vice versa, in the LD editor has been added.

Menu – [Find/Replace] – Find Contact/Coil

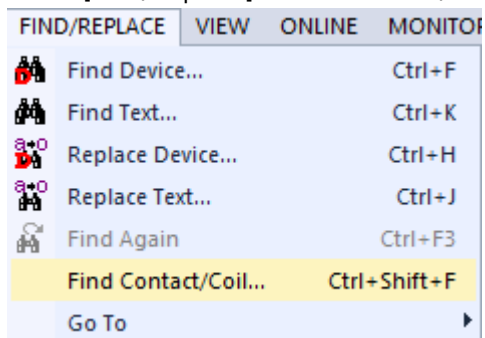

(28) Improved Run/Stop status bar

The status bar is green when the status is in Run mode, and red when the status is in Stop mode.

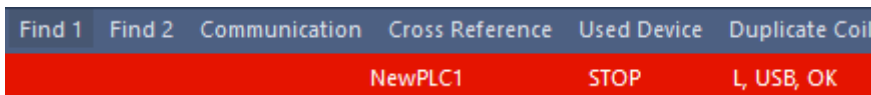
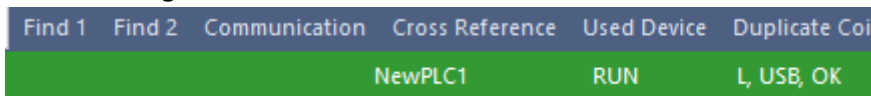

(29) Added display as string option

String option has been added in the variable monitor window.

!wProgram	VALUE			
!wProgram	VALUE[0]		'.'	BYTE
!wProgram	VALUE[1]		'@'	BYTE
!wProgram	VALUE[2]		'A'	BYTE
!wProgram	VALUE[3]		'B'	BYTE
!wProgram	VALUE[4]		'C'	BYTE
!wProgram	VALUE[5]		'D'	BYTE
!wProgram	VALUE[6]		'E'	BYTE
!wProgram	VALUE[7]		'F'	BYTE

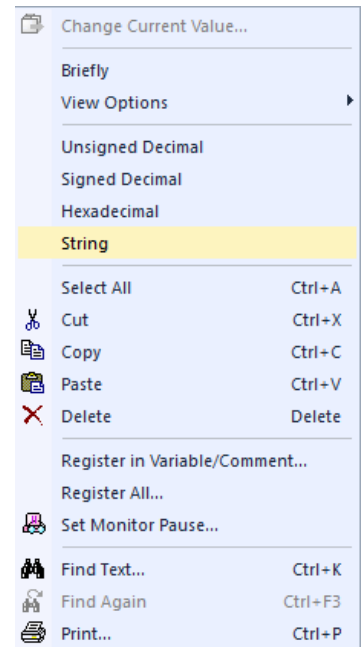

However, when changing the current value, use the type set in the variable.

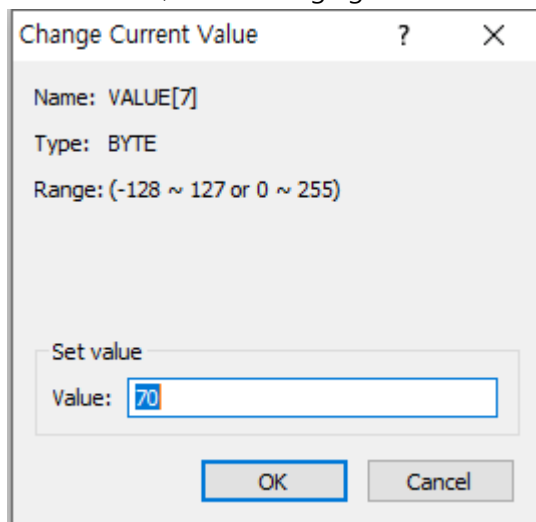

(30) Display different color for online edited rung

To differentiate online edited rungs, a new feature, changing the color of edited rungs, has been added.

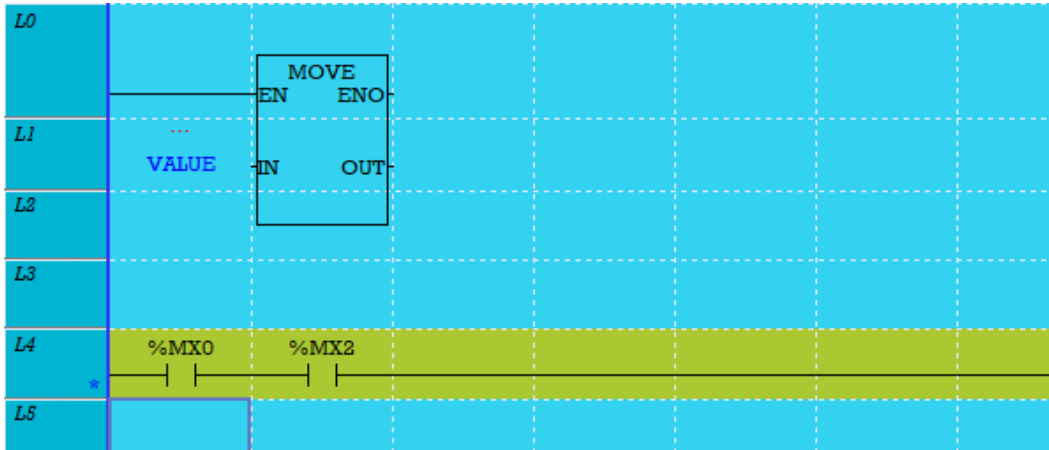

The color of the background and the rung can be personalized in the Options.

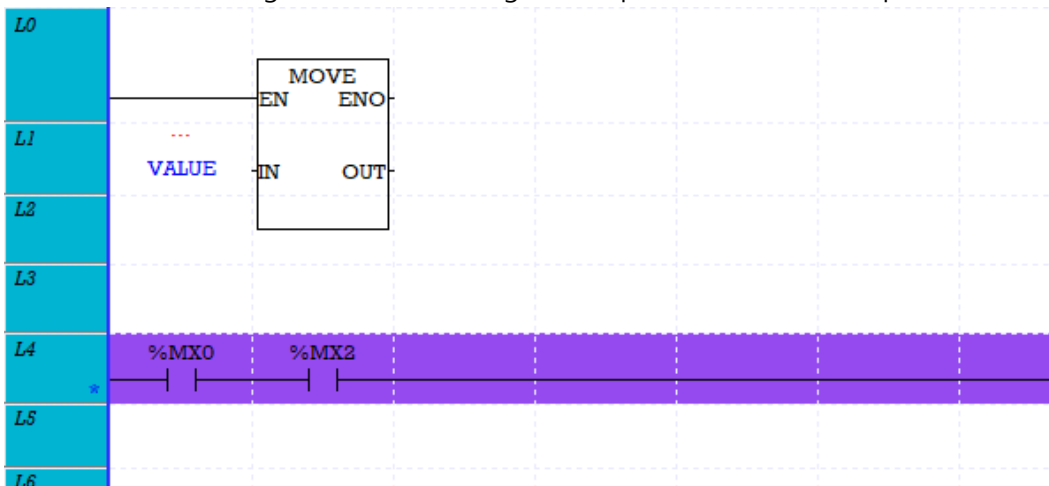

(31) Added ordering feature within the library

Using the Library Manager, users can reorder the functions/function blocks. By clicking the OK button, changes will be applied to the project.

[Move item down]

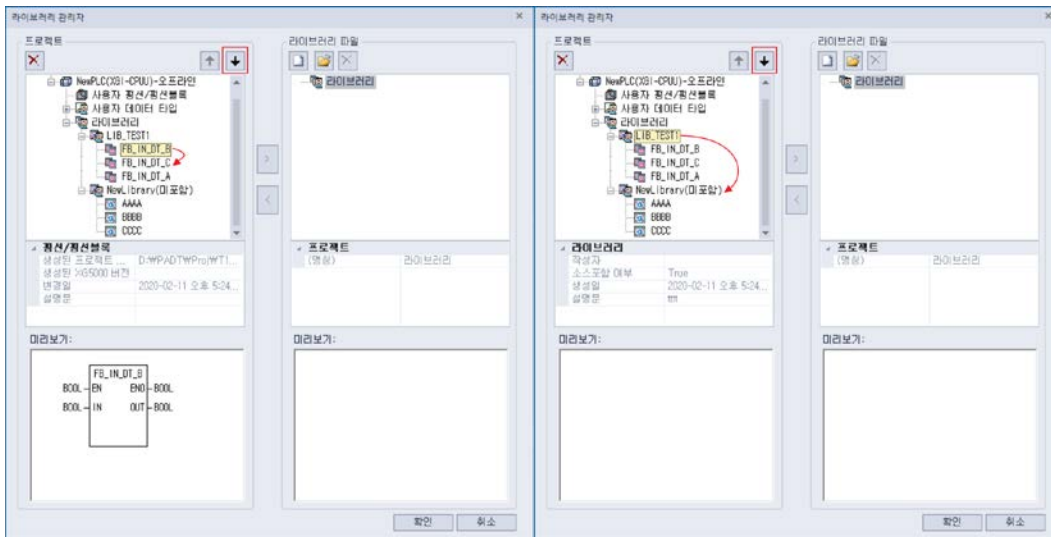

[Move item up]

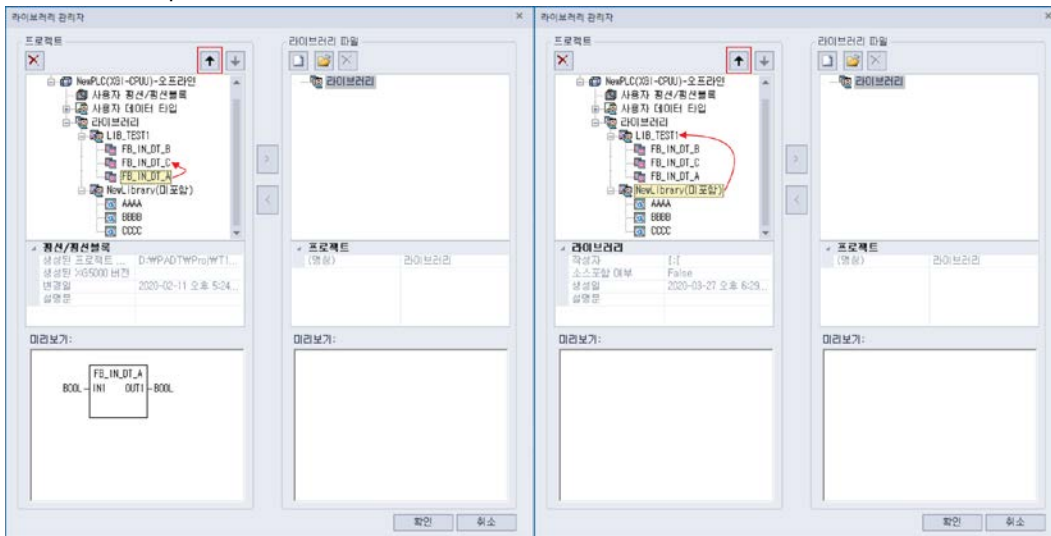

(32) Added XGB user frame, and BCC component (CRC ARC)

CRC ARC entry was added for BCC selections in the user frame defined TAIL for some XGB modules. CRC ARC entries are displayed only for predefined support modules, and can only be downloaded for OS versions that are supported.

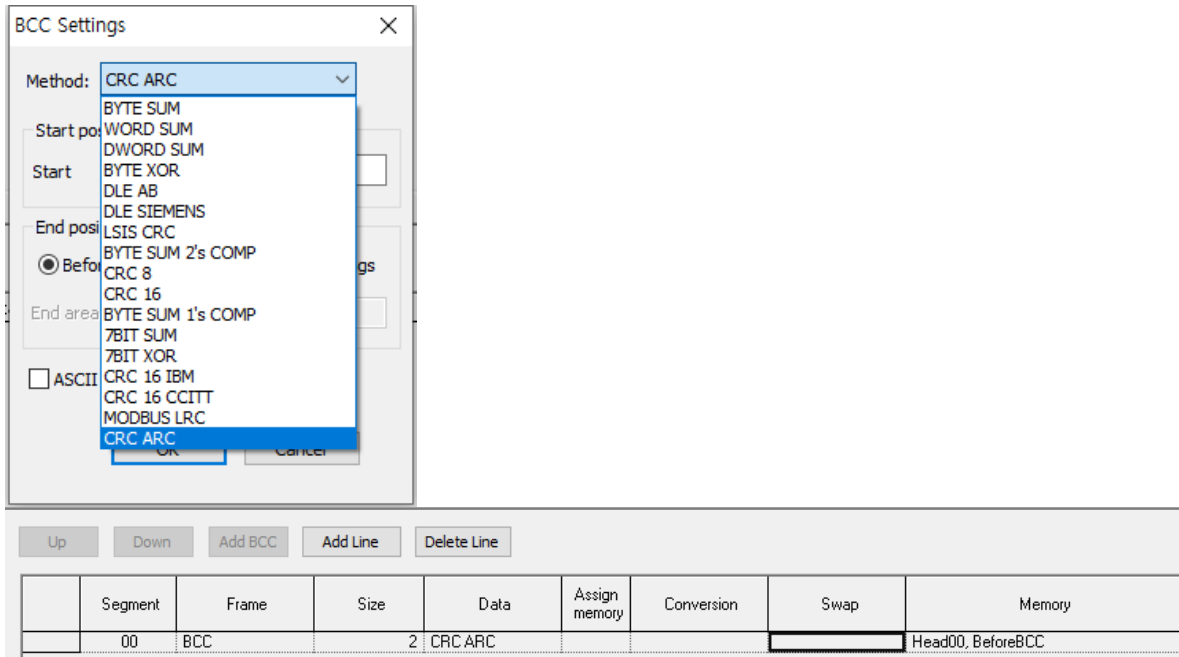

XGB CPU	Applied	Applied version(O/S)
XGB-XBMS	●	V4.00
XGB-XBCH	●	V3.30
XGB-XBCS	●	V2.20
XGB-XBCE	●	V1.50
XGB-XBCU	●	V2.00
XGB-XBMH	●	V1.30
XGB-XBMHP	●	V2.20
XGB-XBMH2	●	V2.20
XGB-XBCXS	●	V1.20
XGB-XECH	●	V3.30
XGB-XECS	●	V2.10
XGB-XECE	●	V1.40
XGB-XECU	●	V2.00
XGB-XEMHP	●	V2.20
XGB-XEMH2	●	V2.20

(33) Added user defined port setting in FNet module basic settings.

User can set the user port in FNet Module(XGL type module)'s [Basic Settings] – [Advanced Settings]. (TCP

and UDP)

Standard Settings - FEnet

Basic Settings Host Table Settings SNTP Setting Sets EIP Server **Advanced Settings**

Custom Port Setting

NONE TCP Port No. 0

UDP Port No. 0

User cannot designate the port used by the module.

- 161, UDP: SNMP server
- 502, TCP: Modbus/TCP server port
- 2002, TCP: LS Loader server port
- 2004, TCP: LS Dedicated server port
- 2005, UDP: LS Dedicated server port
- 2006, UDP: LS High speed link port
- 2007, UDP: LS Station list port
- 2008, UDP: LS Remote station list port
- 2222, UDP: EtherNet/IP Class1 IO port
- 4840, TCP: OPC UA server(default value, it depends on opc ua server settings)
- 5000, UDP: M₁社 server port
- 5002, TCP: M₁社 server port
- 44000, UDP: EtherNet/IP Broadcast port
- 44818, TCP, UDP: EtherNet/IP UCMM port

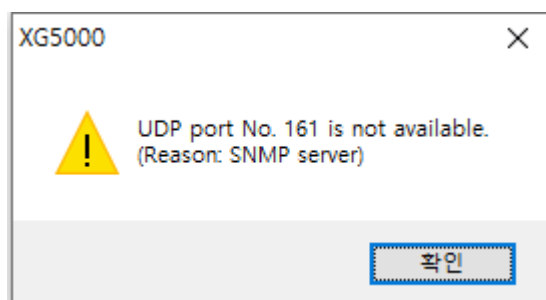

(34) Improved host table settings

Added validation when using enable host table. If the address is missing or duplicate IP is inserted, then an error will pop up.



(35) Changed maximum size of EIP Server (500 → 1400)

Expanded the EIP server settings and smart extension's EIP communication interval from 500 byte to 1400byte. To use 14000 byte the FEnet needs to be the latest version.

- XGL-EFMTB/EFMFB/EFMHB: V8.1 or later version

(36) Added SNTP port settings feature

SNTP feature has been added. By adding the IP and port number it can sync the PLC clock to the NTP server.

- XGL-EFMTB/EFMFB/EFMHB: V8.3 or later version

Standard Settings - FEnet ×

Basic Settings Host Table Settings **SNTP Setting** Sets EIP Server Advanced Settings

Time Synchronization Settings

SNTP (Simple Network Time Protocol)

Operate with SNTP Initialization

NTP Server

	IP Address	Port Number
1		

Synchronization Cycle 30min

Time Zone Setting (UTC+09:00) Seoul

2. Improved Smart Extension

Improved XGL-EFMTB's smart extension service.

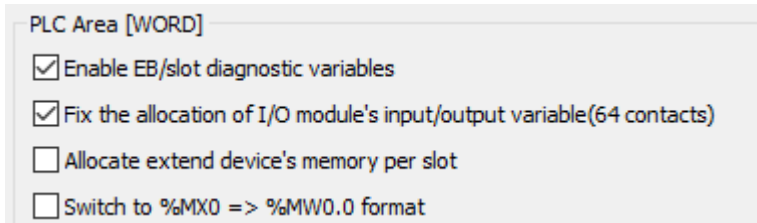

(1) I/O module's I/O variable fixed allocation(64 point) feature

The contacts can be fixed to 64 points for the Smart IO module and the I/O module added to the smart adapter, or allocated to the number of fitted I/O module contacts.(at least 32 points)

(2) Allocate extend device's memory per slot

Allocate the memory of Smart IO module and Smart adapter's in terms of base, or in terms of slot.

(3) Display in %MX0 => %MW0.0 format

In a XGI project's Smart extension's I/O variable allocation window and Diagnostic Variable Assignment window BOOL type can now be displayed in WORD format.

(4) Address allocation of I/O module

Added a feature where I/O module's address can be allocated independently. For modules that have both input and output, it can be set as 'Input addresss/Output Address".

The feature above is only available when 'Allocate extend device's memory slot' is enabled.

[Case 1: Default]

	EB No.	Station No/IP	Slot number	Variable	Type	Device	Monitor value	Comment
1	EB01	1	Slot00					
2				_0000_EB01_RI00	WORD	%MW1000		Input address 00 ~ 15
3				_0000_EB01_RI00P00	BOOL	%MX16000		Input address 00
4				_0000_EB01_RI00P01	BOOL	%MX16001		Input address 01
5				_0000_EB01_RI00P02	BOOL	%MX16002		Input address 02

	EB No.	Station No/IP	Slot number	Variable	Type	Device	Monitor value	Comment
19			Slot01					
20				_0000_EB01_RQ01	WORD	%MW1032		Output address 00 ~ 15
21				_0000_EB01_RQ01P00	BOOL	%MX16512		Output address 00
22				_0000_EB01_RQ01P01	BOOL	%MX16513		Output address 01
23				_0000_EB01_RQ01P02	BOOL	%MX16514		Output address 02

[Case 2: Input %MW1000, Output %MW2000]

PLC Area [WORD]

Enable EB/slot diagnostic variables

Fix the allocation of I/O module's input/output variable(64 contacts)

Allocate extend device's memory per slot

Switch to %MX0 => %MW0.0 format

Address	Start device	Size
Input/Output Vari	%MW1000	500
Diagnostic	%MW1500	100

(* Sets start address and its size for the variables used for Smart Extension *)

Format: Hexadecimal Variable Setting

	EB No.	Station No/IP	Slot number	Variable	Type	Device	Monitor value	Comment
1	EB01	1	Slot00			%MW1000		
2				__0000_EB01_RI00	WORD	%MW1000		Input address 00 ~ 15
3				__0000_EB01_RI00P00	BOOL	%MX16000		Input address 00
4				__0000_EB01_RI00P01	BOOL	%MX16001		Input address 01
5				__0000_EB01_RI00P02	BOOL	%MX16002		Input address 02

Format: Hexadecimal Variable Setting

	EB No.	Station No/IP	Slot number	Variable	Type	Device	Monitor value	Comment
19			Slot01		WORD	%MW2000		
20				__0000_EB01_RQ01	WORD	%MW2000		Output address 00 ~ 15
21				__0000_EB01_RQ01P00	BOOL	%MX32000		Output address 00
22				__0000_EB01_RQ01P01	BOOL	%MX32001		Output address 01
23				__0000_EB01_RQ01P02	BOOL	%MX32002		Output address 02

(5) Save, compare autoscan

(※ Following feature is available on XGL-EFMTB V8.10 or late version)

Added a feature where the user can compare the previous RAPIenet Autoscan result and the current RAPIenet autoscan result.

Run RAPIenet autoscan from [Online] > [Communication Module Setting and Diagnosis] > [System Diagnosis].

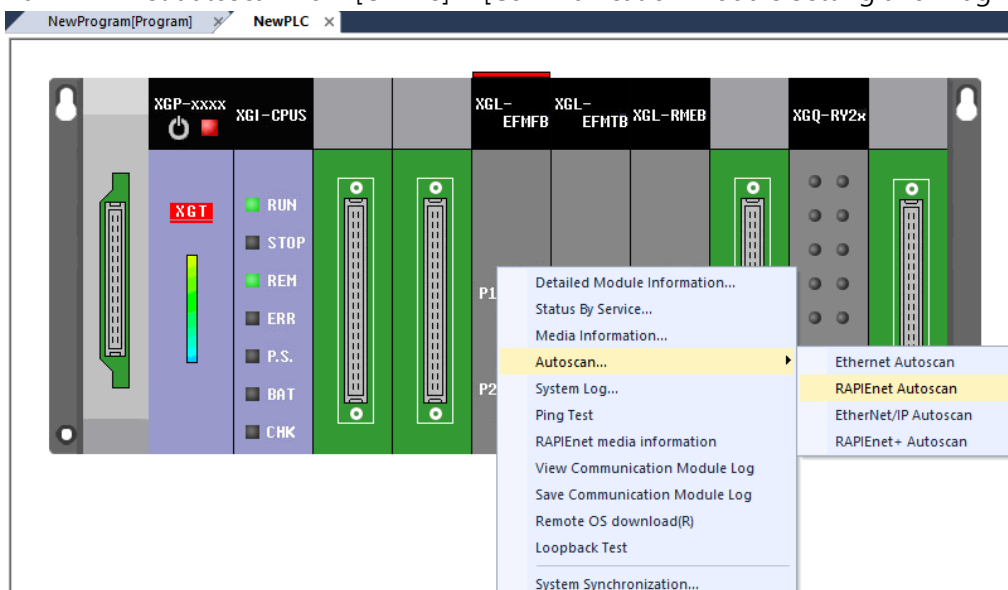

Click [Save] button to save the current RAPIEnet autoscan information to the module.

Click [Compare] button, to compare the current RAPIEnet autoscan information with the saved information.

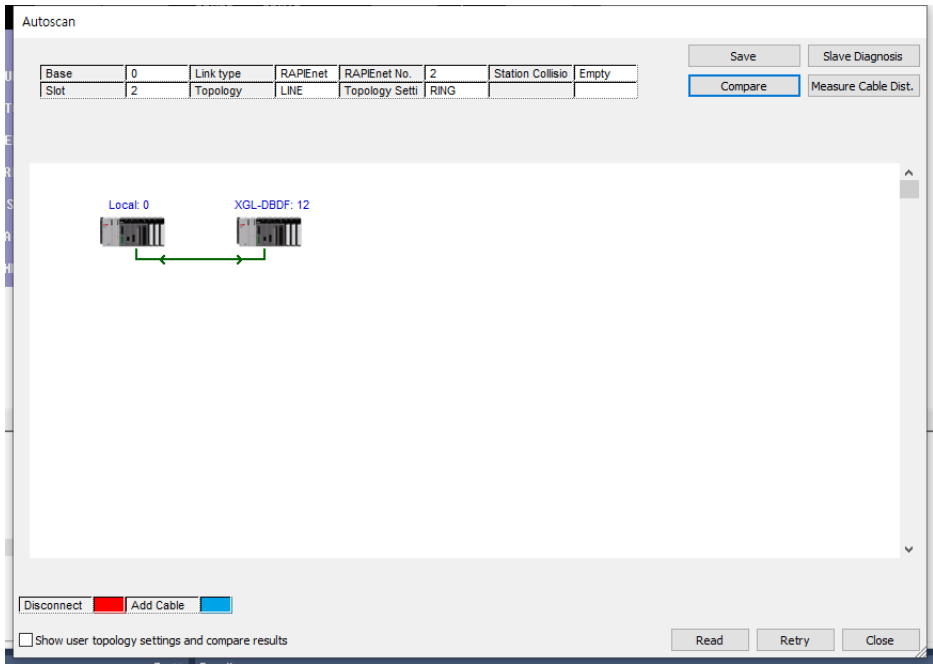

(6) Added mark RAPIEnet Autoscan topology feature

(※ Following feature is available on EFMTB V8.10 or late version)

If the topology information is different between the RAPIEnet autoscanned user topology and the current topology information, then mark and display the difference in the window.

To set the topology information, go to the project window [Undefined Network] > [Smart Extension] > [Master Setting] > [Topology Configuration].

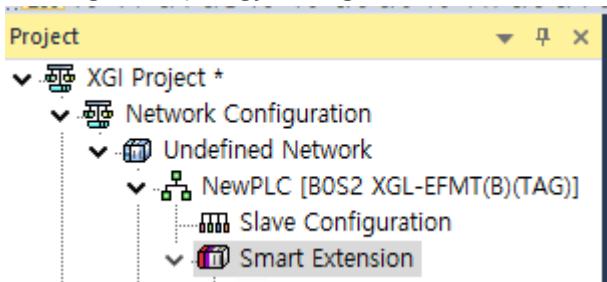

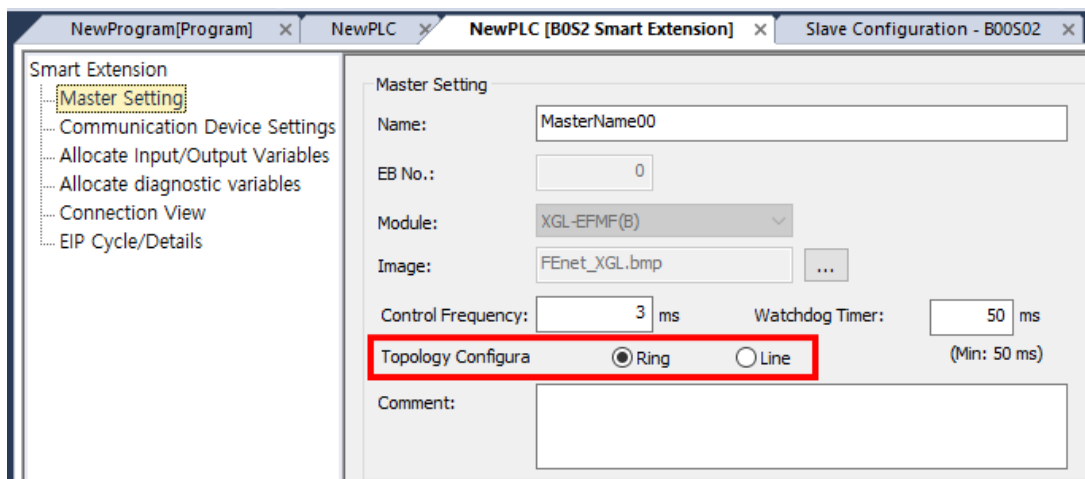

Operate RAPIenet Autoscan by [Online] > [Communication Module Setting and Diagnosis] > [System Diagnosis]

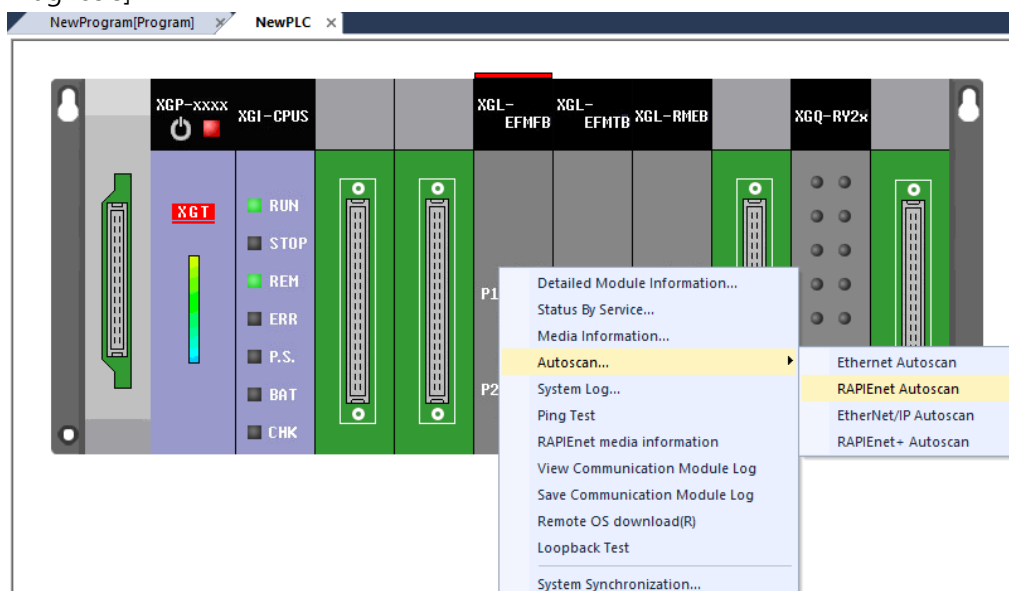

User set topology information

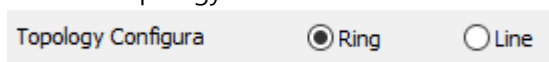

If the topology information differs than it will mark using red lines to show that the topology has been modified.

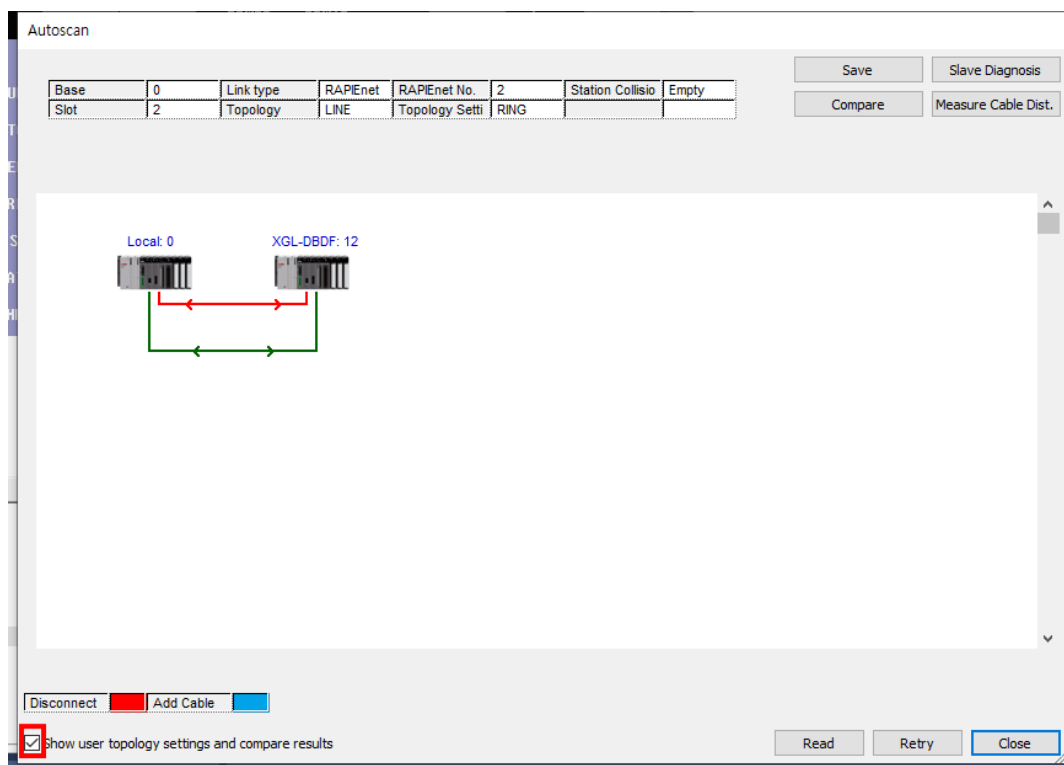

If it's the opposite it will mark using blue lines.

3. Error Correction

- (1) **Fixed an error, when FEnet communication module is included in the network component, where partial smart extension diagnosis variables will not be added to the global variable or variable/comment list.**

(2) **Fixed issue with changing shortcut key**

Fixed an issue with the intersection point of contact, coil and horizontal line.

(3) **Fixed an error where rung description ignored blank spaces**

Fixed an issue where if a rung description starts with blank spaces, the blank spaces were omitted.

(4) **Fixed an error with creating a project folder during Save As...**

Fixed an error where the folder won't show when clicking [Find] during Save As. If D:\# is selected, the folder's name is created with the project's name.

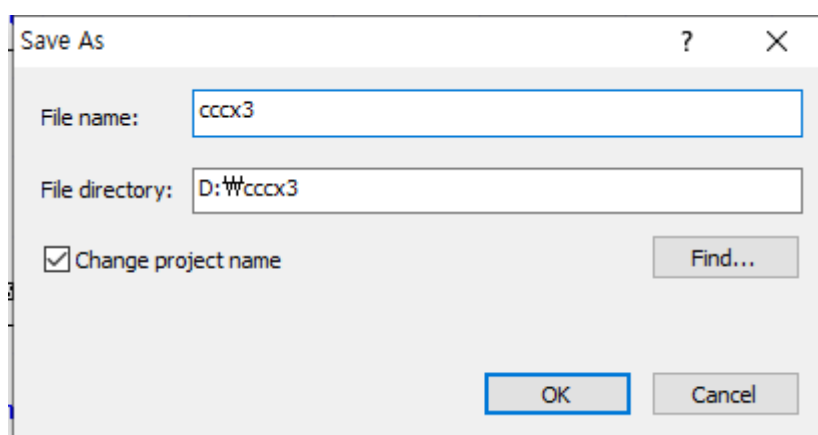

(5) **Fixed an issue when importing user data type**

Fixed an issue that occurred when the user used [Read from text file] from the menu to read a file that was created from [Save to text file]. The variables weren't displayed properly on user data type window.

(6) **Fixed an issue where CPT variable variables get deleted when clicking [Remove all unused variable/comments]**

Fixed an issue where CPT variable variables get deleted when clicking [Remove all unused variable/comments]

(7) **Fixed an error that occurs when comparing P2P triggering conditions**

Fixed the issue where, the Compare Project feature wasn't able to detect the problem with P2p block triggering conditions.