

Advanced S100 User Sequence

Contents

- | | |
|------------------------------|--|
| I. Advanced knowledge | II. Advanced Examples |
| 1. Data format type | 1. Output counter |
| 2. Digital I/O control | 2. Acc/Dec time transition speed |
| 3. Analysis of the value | 3. Variable speed operation |
| 4. Programming cautions | 4. Sequence with multi-functional input |
| | 5. Timer On/Off control |
| | 6. Multi-speed operation with DI |
| | 7. Torque boost control through PI control |
| | 8. Sequence using virtual DI |
| | Attach. Major Comm. addresses |

2016 SEP.

A&D)Corporate Support Team

Junkyu Kim

I . Advanced knowledge

1. Advanced knowledge

1. Data format type

- **Integer type**

→ Output range is -9999~9999.

→ Function block: Functions except for AND/OR/XOR/ANDOR/BITSET/BITCLEAR/BITTEST.

- **Binary digit type**

→ This type is expressed as 0 or 1, each is Off(False) or On(True).

→ Function block: AND/OR/XOR/ANDOR/BITSET/BITCLEAR/BITTEST

→ Results of this type is expressed as the pictures below, There are any problem in calculating with other functions except for SWITCH function. If you input binary digit type parameters to SWITCH function, because of the error, the output is -1.

LCD keypad

[On/Off]



On Off

7-Seg keypad

[On/Off]

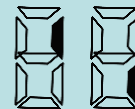

On Off

1. Advanced knowledge

2. Digital input/output control

• Communication multi-functional input(0385) control

Bit	Value	Description	Bit	Value	Description
B15	$2^{15}=32,768$	Reserved	B7	$2^7=128$	Virtual DI 8 (CM-77)
B14	$2^{14}=16,384$	Reserved	B6	$2^6=64$	Virtual DI 7 (CM-76)
B13	$2^{13}=8,192$	Reserved	B5	$2^5=32$	Virtual DI 6 (CM-75)
B12	$2^{12}=4,096$	Reserved	B4	$2^4=16$	Virtual DI 5 (CM-74)
B11	$2^{11}=2,048$	Reserved	B3	$2^3=8$	Virtual DI 4 (CM-73)
B10	$2^{10}=1,024$	Reserved	B2	$2^2=4$	Virtual DI 3 (CM-72)
B9	$2^9=512$	Reserved	B1	$2^1=2$	Virtual DI 2 (CM-71)
B8	$2^8=256$	Reserved	B0	$2^0=1$	Virtual DI 1 (CM-70)

Input value example)

- No input= 0
- Virtual DI 1 input(B0)= 1
- Virtual DI 1+DI 2 input= $1+2= 3$
- Virtual DI 1+DI 3 input= $1+4= 5$

• Digital output(0386) control

Bit	Value	Description	Bit	Value	Description
B15	$2^{15}=32,768$	Reserved	B7	$2^7=128$	Reserved
B14	$2^{14}=16,384$	Reserved	B6	$2^6=64$	Reserved
B13	$2^{13}=8,192$	Reserved	B5	$2^5=32$	Reserved
B12	$2^{12}=4,096$	Reserved	B4	$2^4=16$	Reserved
B11	$2^{11}=2,048$	Reserved	B3	$2^3=8$	Reserved
B10	$2^{10}=1,024$	Reserved	B2	$2^2=4$	Reserved
B9	$2^9=512$	Reserved	B1	$2^1=2$	Multi-func. output 1(Q1)
B8	$2^8=256$	Reserved	B0	$2^0=1$	Multi-func. relay 1(R1)

Input value example)

- No output=0
- Relay1 output= 1
- Relay1+Q1 output= $1+2= 3$

1. Advanced knowledge

3. Analysis of the value

• Operation status(000E) monitoring

Bit	Value	Description
B15	$2^{15}=32,768$	0: Remote, 1: Local
B14	$2^{14}=16,384$	1: Frequency command source by communication
B13	$2^{13}=8,192$	1: Operation command source by communication
B12	$2^{12}=4,096$	REV operation command
B11	$2^{11}=2,048$	FWD operation command
B10	$2^{10}=1,024$	Brake release signal
B9	$2^9=512$	Jog mode
B8	$2^8=256$	Stopping

Bit	Value	Description
B7	$2^7=128$	DC braking
B6	$2^6=64$	Speed reached
B5	$2^5=32$	Decelerating
B4	$2^4=16$	Accelerating
B3	$2^3=8$	Fault(Trip)
B2	$2^2=4$	Run in REV direction
B1	$2^1=2$	Run in FWD direction
B0	$2^0=1$	Stopped

Monitoring value example)

- Stopped(B0)= 1
- FWD accelerating(B1+B4+B11)= $2+16+2048= 2066$
- FWD decelerating(B1+B5+B11)= $2+32+2048= 2082$
- FWD stopping(B1+B8)= $2+256= 258$
- FWD speed reached(B1+B6+B11)= $2+64+2048= 2114$

• Multi-functional input(155A) /output status(1629) monitoring

Bit	Value	Description
B6	$2^6=64$	P7 terminal Setting
B5	$2^5=32$	P6 terminal Setting
B4	$2^4=16$	P5 terminal Setting
B3	$2^3=8$	P4 terminal Setting
B2	$2^2=4$	P3 terminal Setting
B1	$2^1=2$	P2 terminal Setting
B0	$2^0=1$	P1 terminal Setting

Bit	Value	Description
B1	$2^1=2$	Multi-functional output 1 (Q1)
B0	$2^0=1$	Multi-functional relay 1 (R1)

Monitoring value example)

- No input=0
- P1 input(B0)= 1
- P1+P2 input(B0+B1)= $1+2= 3$
- Relay1 output= 1
- Relay1+Q1 output= $1+2= 3$

1. Advanced knowledge

4. Cautions

- **In case of using several same function blocks linked to the one parameter.**

- It's easy to make an error when we want to make a sequence that the specific value is changes regularly at every loop time.
- Since execution cycle range is 0.01~1 sec, the target parameter changes very fast and you may not notice the changes.

- **In case of changing parameters during user sequence operation.**

- If user sequence is activated, parameters cannot be adjusted during an operation. But, void parameters and parameters of other groups can.
- When you want to change the value of changeable parameter, parameters must be adjusted carefully.
- For example, in case of operating an ac drive with the virtual DI, if you change the setting of virtual DI during an operation, there is any method to stop the operation except to shut down the power.
- When you need to change parameter during an operation, examine thoroughly before changing parameter.

- **Check the scale of the parameter**

- If the linked parameters' scale is different each other, scale is not automatically converted and you may can't get the results that you wanted.
- For example, scale of the command frequency(1101) is 0.01 and 6000 means 60Hz. So, you should input 6000 to set the 60Hz.

II. Advanced Examples

II. Advanced Examples

Example 1 – Output counter (1)

- 1-1. Outline

- ✓ This is an example about counting the number of times signal outputted through the multi-functional terminal
- ✓ Used function block: BITTEST, UPCOUNT

- 1-2. Diagram

- ✓ Make inverter outputs the trip signal by using multi-functional input terminal . Then, check out the number of times.

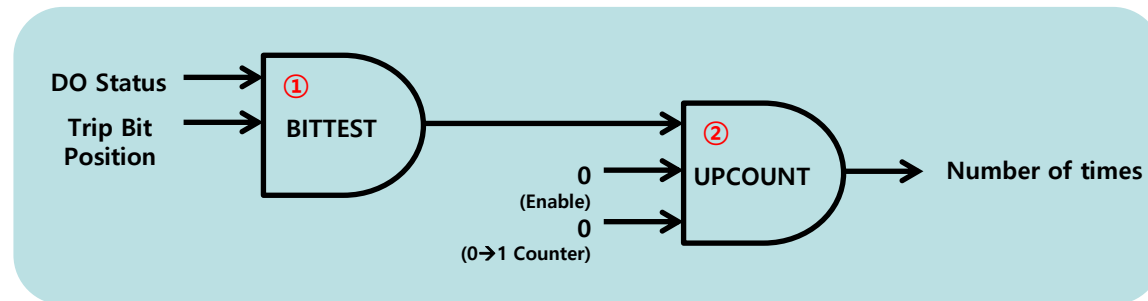

Continued to next page

II. Advanced Examples

Example 1 – Output counter (2)

- 1-3. Parameter setting

- ✓ Comm. addresses

- User Output 1 : 1E05, User Output 2 : 1E0A, User Output 3: 1E0F
 - Void Para 1 : 1D1F, Void Para 2 : 1D20, Void Para 3 : 1D21, Void Para 4 : 1D22
 - Command frequency : 1101, DO Status: 1629

Code	Name	Setting
OU-01	A01 mode	0: Freq
APP-02	User Seq. En	1 : Yes
US-02	User Seq. Loop Time	5: 1.0S
US-01	User Seq. Con	0 : Stop

Code	Name	Setting
US-31	Void Para 1	0
US-32	Void Para 2	1

Code	Name	Setting
UF-01	User Func 1	21: BITTEST
UF-02	User Input 1-A	1629
UF-03	User Input 1-B	1D20
UF-04	User Input 1-C	-
UF-05	User Output 1	-

Code	Name	Setting
OU-31	Relay1	29: Trip

Code	Name	Setting
UF-06	User Func 2	27: UPCOUNT
UF-07	User Input 2-A	1E05
UF-08	User Input 2-B	1D1F
UF-09	User Input 2-C	1D1F
UF-10	User Output 2	-

Code	Name	Setting
IN-67	P3 Define	4: EXT

Continued to next page

II. Advanced Examples

Example 1 – Output counter (3)

- 1-4. Results

- ✓ Results: Make some trip signal output and check out the number of times at US-10(User Output2).

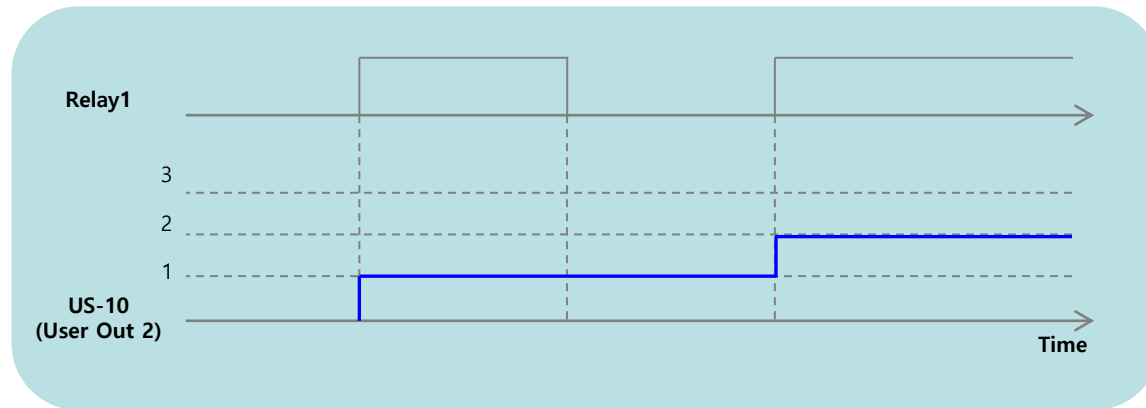

II. Advanced Examples

Example 2 – Acceleration time transition speed (1)

● 2-1. Outline

- ✓ This is an example about changing of acc/dec time by acc/dec time switching frequency setting.
- ✓ Used function block: COMPARE-GT, SWITCH

● 2-2. Diagram

- ✓ If the output frequency reaches the specific frequency, Accelerating/Decelerating time is automatically changed by setting of COMPARE-GT function block.

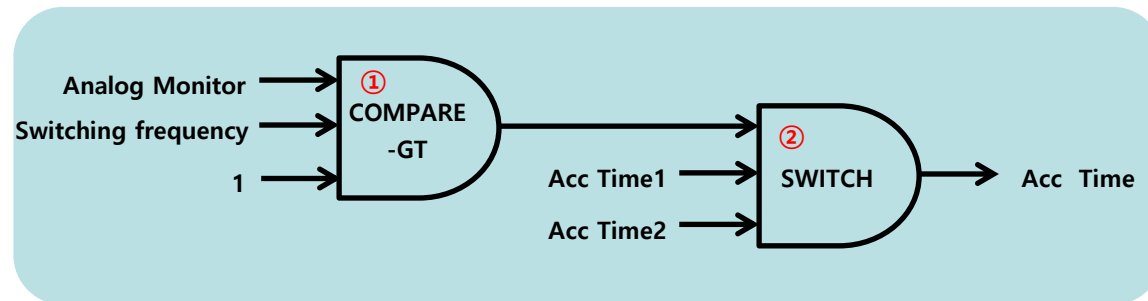

Continued to next page

II. Advanced Examples

Example 2 – Acceleration time transition speed (2)

● 2-3. Parameter setting

✓ Comm. addresses

- Analog Output 1 monitor: 1606, Acc Time: 1103

- User Output 1 : 1E05

- Void Para 1 : 1D1F, Void Para 2 : 1D20, Void Para 3 : 1D21, Void Para 4: 1D22, Void Para 5: 1D23

Code	Name	Setting
OU-01	A01 mode	0: Freq
APP-02	User Seq. En	1 : Yes
US-02	User Seq. Loop Time	5: 1.0S
US-12	Link User Out 2	1103
US-01	User Seq. Con	0 : Stop

Code	Name	Setting
US-31	Void Para 1	500(50%)
US-32	Void Para 2	1
US-33	Void Para 3	200
US-34	Void Para 4	100
US-35	Void Para 5	250(25%)

Code	Name	Setting
UF-01	User Func 1	11:Compar e-GT
UF-02	User Input 1-A	1606
UF-03	User Input 1-B	1D1F
UF-04	User Input 1-C	1D20
UF-05	User Output 1	-

Code	Name	Setting
UF-06	User Func 2	20:SWITCH
UF-07	User Input 2-A	1E05
UF-08	User Input 2-B	1D22
UF-09	User Input 2-C	1D21
UF-10	User Output 2	-

Continued to next page

II. Advanced Examples

Example 2 – Acc/Dec time transition speed (3)

● 2-4. Results

- ✓ Results: Check if accelerating takes 20 sec under 30Hz and 10 sec over 30Hz.
- ✓ Practice: Try to make another pattern

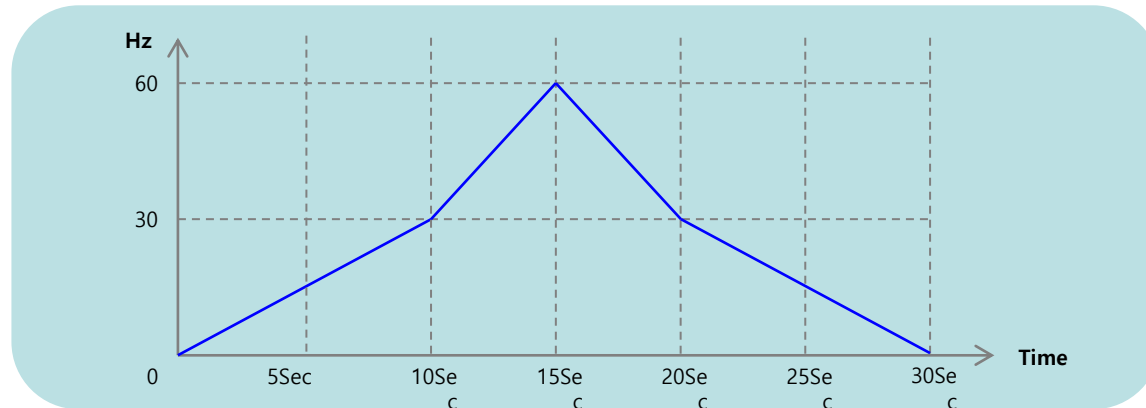

II. Advanced Examples

Example 3 – Variable speed operation (1)

● 3-1. Outline

- ✓ Change the speed to preset frequency at regular intervals
- ✓ Used function block: ADDSUB, TIMER, COMPARE-GTEQ, SWITCH

● 3-2. Diagram

- ✓ Frequency is automatically changed at regular intervals by using TIMER function.

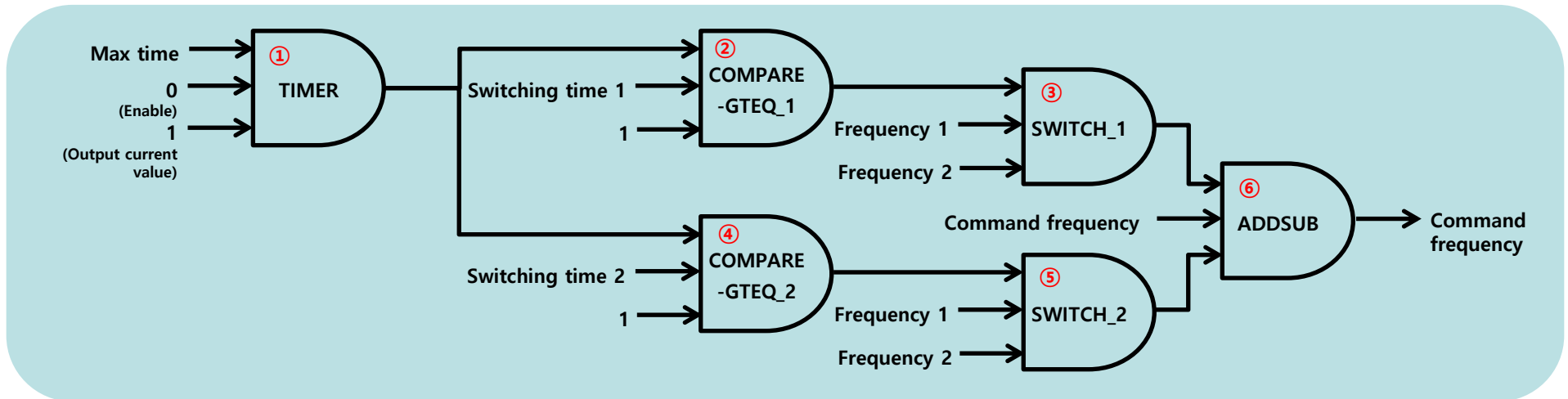

Continued to next page

II. Advanced Examples

Example 3 – Variable speed operation (2)

● 3-3. Parameter setting (1)

✓ Comm. addresses

- User Output 1 : 1E05, User Output 2 : 1E0A, User Output 3: 1E0F, User Output 4: 1E14 ,User Output 5: 1E19, User Output 6: 1E1E
- Void Para 1 : 1D1F, Void Para 2 : 1D20, Void Para 3 : 1D21, Void Para 4: 1D22, Void Para 5: 1D23, Void Para 6: 1D24
- Command frequency : 1101

Code	Name	Setting
APP-02	User Seq. En	1 : Yes
US-02	User Seq. Loop Time	5: 1.0S
US-11	Link User Out 1	1101
US-01	User Seq. Con	0 : Stop

Code	Parameter	Setting
DR-06	Cmd Source	1:Fx/Rx-1
DR-07	Freq Ref Src	0:Keypad-1

Code	Name	Setting
US-31	Void Para 1	0
US-32	Void Para 2	1
US-33	Void Para 3	30
US-34	Void Para 4	60
US-35	Void Para 5	1500
US-36	Void Para 6	4000

Code	Name	Setting
UF-01	User Func 1	3:ADDSUB
UF-02	User Input 1-A	1E14 (Out4)
UF-03	User Input 1-B	1D23
UF-04	User Input 1-C	1E1E (Out6)
UF-05	User Output 1	-

Continued to next page

II. Advanced Examples

Example 3 – Variable speed operation (3)

- 3-3. Parameter setting (2)

Code	Name	Setting
UF-6	User Func 2	14:TIMER
UF-7	User Input 2-A	1D22
UF-8	User Input 2-B	1D1F
UF-9	User Input 2-C	1D20
UF-10	User Output 2	-

Code	Name	Setting
UF-11	User Func 3	11:Compare-GTEQ
UF-12	User Input 3-A	1E0A
UF-13	User Input 3-B	1D1F
UF-14	User Input 3-C	1D20
UF-15	User Output 3	-

Code	Name	Setting
UF-16	User Func 4	20:SWITCH
UF-17	User Input 4-A	1E0F
UF-18	User Input 4-B	1D24
UF-19	User Input 4-C	1D1F
UF-20	User Output 4	-

Code	Name	Setting
UF-21	User Func 5	11:Compare-GTEQ
UF-22	User Input 5-A	1E0A
UF-23	User Input 5-B	1D21
UF-24	User Input 5-C	1D20
UF-25	User Output 5	-

Code	Name	Setting
UF-26	User Func 6	20:SWITCH
UF-27	User Input 6-A	1E19
UF-28	User Input 6-B	1D24
UF-29	User Input 6-C	1D1F
UF-30	User Output 6	-

Continued to next page

II. Advanced Examples

Example 3 – Variable speed operation (4)

● 3-4. Results

- ✓ Results: Frequency is changed like 55.00 → 15.00 → 55.00 at every 30 sec.
- ✓ Practice 1: Change the frequency for ADDSUB and time for TIMER
- ✓ Practice 2: Make 3 step freq. changing graph with 1 more COMPARE-GTEQ and SWITCH package.

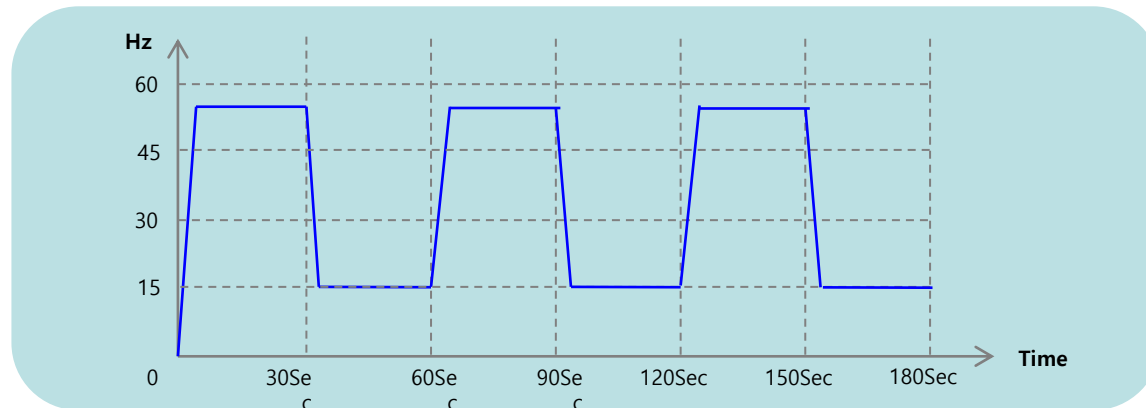

II. Advanced Examples

Example 4 – Sequence with multi-functional input (1)

● 4-1. Outline

- ✓ Frequency can be changed by inputting FX, RX terminal signal.
- ✓ Used function block: BITTEST, UPCOUNT, DOWNCOUNT, ADD, ABS, COMPARE-EQUAL, MAX.

● 4-2. Diagram

- ✓ If the FX signal is inputted, frequency-step goes up and if the RX signal is inputted, frequency-step goes down.
- ✓ Changing of 3-step speed is possible from step0 to step2.

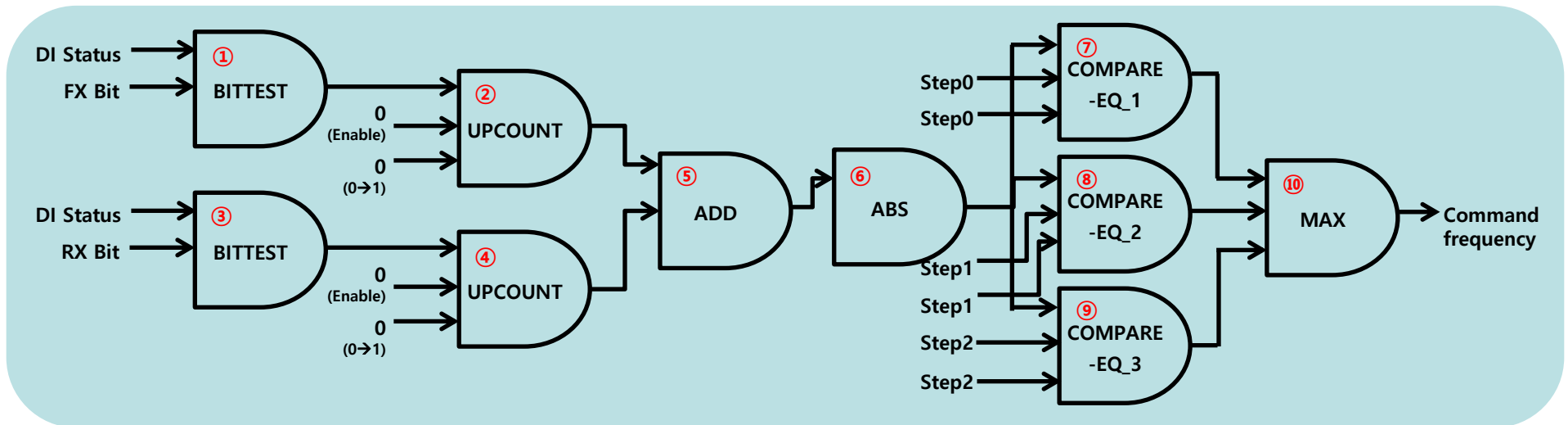

Continued to next page

II. Advanced Examples

Example 4 – Sequence with multi-functional input (2)

● 4-3. Parameter setting (1)

- ✓ Step0: 10Hz, Step1: 30Hz, Step2: 60Hz
- ✓ Comm. Addresses
 - DI Status: 155A / Void Para1~Void Para6: 1D1F~1D24 / Out1: 1E05 / Command frequency.: 1101

Code	Name	Setting
OU-01	A01 mode	0: Freq
APP-02	User Seq. En	1 : Yes
US-02	User Seq. Loop Time	5: 1.0S
US-19	Link User Out 9	1101
US-01	User Seq. Con	0 : Stop
DR-06	Cmd Source	1:Fx/Rx-1
DR-07	Freq Ref Src	0:Keypad-1

Code	Name	Setting
UF-06	User Func 2	27: UPCOUNT
UF-07	User Input 2-A	1E05
UF-08	User Input 2-B	1D20
UF-09	User Input 2-C	1D20
UF-10	User Output 2	-

Code	Name	Setting
US-31	Void Para 1	1
US-32	Void Para 2	0
US-33	Void Para 3	2
US-34	Void Para 4	1000
US-35	Void Para 5	3000
US-36	Void Para 6	6000

Code	Name	Setting
UF-06	User Func 3	21: BITTEST
UF-07	User Input 3-A	155A
UF-08	User Input 3-B	1D21
UF-09	User Input 3-C	-
UF-10	User Output 3	-

Code	Name	Setting
IN-65	P1 Define	1: FX
IN-66	P2 Define	2: RX

Code	Name	Setting
UF-01	User Func 1	21: BITTEST
UF-02	User Input 1-A	155A
UF-03	User Input 1-B	1D1F

Code	Name	Setting
UF-11	User Func 4	28:DOWN COUNT
UF-12	User Input 4-A	1E0F
UF-13	User Input 4-B	1D20
UF-14	User Input 4-C	1D20
UF-15	User Output 4	-

Continued to next page

II. Advanced Examples

Example 4 – Sequence with multi-functional input (3)

● 4-3. Parameter setting (2)

✓ Comm. addresses: Out2: 1E0A / Out3: 1E0F / Out4: 1E14 / Out5: 1E19 / Out6: 1E1E / Out7: 1E23 / Out8: 1E28 / Out9: 1E2D

Code	Name	Setting
UF-16	User Func 5	1:ADD
UF-17	User Input 5-A	1E0A
UF-18	User Input 5-B	1E14
UF-19	User Input 5-C	-
UF-20	User Output 5	-

Code	Name	Setting
UF-21	User Func 6	6:ABS
UF-22	User Input 6-A	1E19
UF-23	User Input 6-B	-
UF-24	User Input 6-C	-
UF-25	User Output 6	-

Code	Name	Setting
UF-26	User Func 7	12:Comp are-EQ
UF-27	User Input 7-A	1E1E
UF-28	User Input 7-B	1D1F
UF-29	User Input 7-C	1D22
UF-30	User Output 7	-

Code	Name	Setting
UF-31	User Func 8	12:Comp are-EQ
UF-32	User Input 8-A	1E1E
UF-33	User Input 8-B	1D1F
UF-34	User Input 8-C	1D23
UF-35	User Output 8	-

Code	Name	Setting
UF-36	User Func 9	12:Comp are-EQ
UF-37	User Input 9-A	1E1E
UF-38	User Input 9-B	1D21
UF-39	User Input 9-C	1D24
UF-40	User Output 9	-

Code	Name	Setting
UF-41	User Func 10	5:MAX
UF-42	User Input 10-A	1E23
UF-43	User Input 10-B	1E28
UF-44	User Input 10-C	1E2D
UF-45	User Output 10	-

Continued to next page

II. Advanced Examples

Example 4 – Sequence with multi-functional input (4)

● 4-4. Results

- ✓ Results: At the beginning, command frequency is 10Hz. After inputting FX or RX signal, step is determined by difference between the number of inputting FX and RX.
- ✓ Practice: With more PI terminals and UPCOUNT blocks, you can make more steps

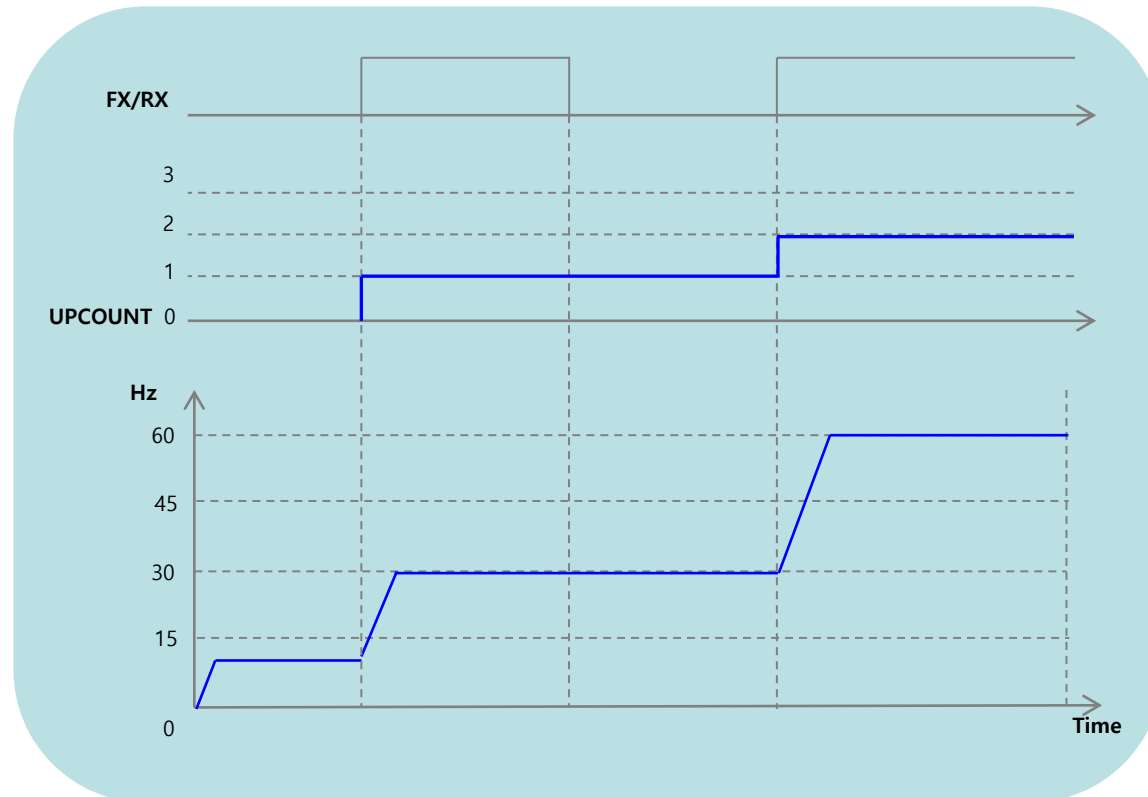

II. Advanced Examples

Example 5 – Timer On/Off control (1)

● 5-1. Outline

- ✓ Timer can be turned on or off by inputting a run enable signal.
- ✓ Used function block: BITTEST, NEGATE, TIMER

● 5-2. Diagram

- ✓ Timer can be turned on or off by inputting a multi-functional terminal signal that is set to run enable.

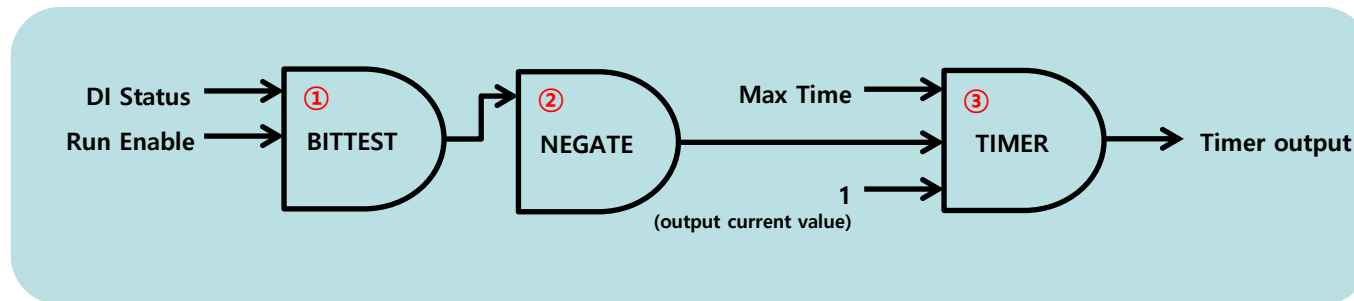

Continued to next page

II. Advanced Examples

Example 5 – Timer On/Off control (2)

● 5-3. Parameter setting

- ✓ Comm. addresses
 - User Output 1 : 1E05
 - Void Para 1 : 1D1F, Void Para 2 : 1D20, Void Para 3 : 1D21

Code	Name	Setting
OU-01	A01 mode	0: Freq
APP-02	User Seq. En	1 : Yes
US-02	User Seq. Loop Time	5: 1.0S
US-01	User Seq. Con	0 : Stop

Code	Name	Setting
US-31	Void Para 1	3
US-32	Void Para 2	60
US-33	Void Para 3	1
IN-67	P3 Define	13: Run Enable

Code	Name	Setting
UF-01	User Func 1	21: BITTEST
UF-02	User Input 1-A	155A
UF-03	User Input 1-B	1D1F
UF-04	User Input 1-C	-
UF-05	User Output 1	-

Code	Name	Setting
UF-06	User Func 2	14: TIMER
UF-07	User Input 2-A	1D20
UF-08	User Input 2-B	1E05
UF-09	User Input 2-C	1D21
UF-10	User Output 2	-

Continued to next page

II. Advanced Examples

Example 5 – Timer On/Off control (3)

● 5-4. Results

- ✓ Results: When the run enable signal is off, check whether the output value of TIMER is 0.
- ✓ Practice: Try to use TIMER in other practices related to Acc/Dec

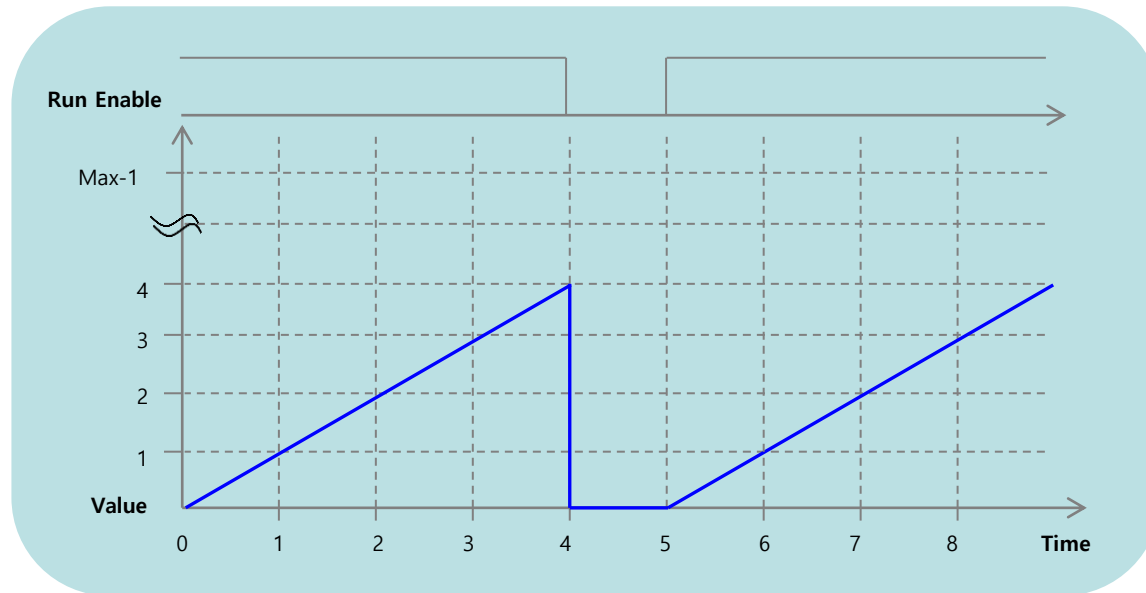

II. Advanced Examples

Example 6 – Multi-speed Operation with DI (1)

● 6-1. Outline

- ✓ Multi-speed operation can be possible by using multi functional terminal (set as speed-L, Speed-M).
- ✓ Used function block: BITTEST, MPYDIV, ADD, Compare-Equal, MAX

● 6-2. Diagram

- ✓ In this example, multi-speed operation can be possible by using multi-functional terminal.
- ✓ If you use FX and RX input as a signal of Speed-L, Speed-M, it is possible to change the speed and start operation at the same time.
- ✓ Changing of 3-step speed is possible from step0 to step2.

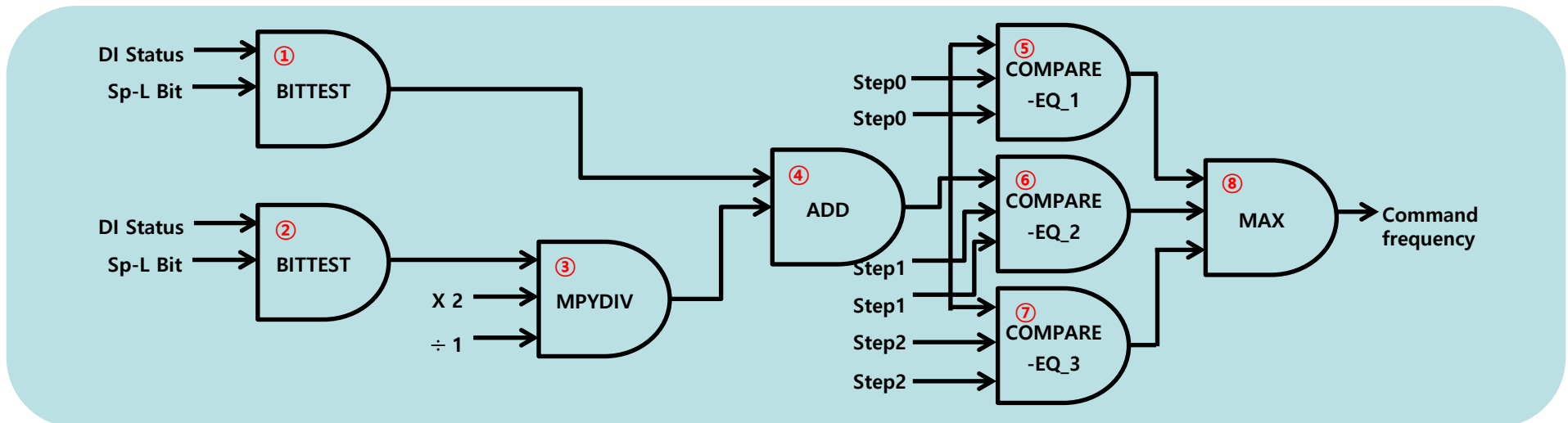

Continued to next page

II. Advanced Examples

Example 6 – Multi-speed Operation with DI (2)

● 6-3. Parameter setting (1)

- ✓ Step0: 10Hz, Step1: 30Hz, Step2: 60Hz
- ✓ Comm. addresses: DI Status: 155A / Void Para1~Void Para8: 1D1F~1D26 / Command frequency.: 1101

Code	Name	Setting
OU-01	A01 mode	0: Freq
APP-02	User Seq. En	1 : Yes
US-02	User Seq. Loop Time	5: 1.0S
US-18	Link User Out 8	1101
US-01	User Seq. Con	0 : Stop

Code	Name	Setting
US-31	Void Para 1	0
US-32	Void Para 2	1
US-33	Void Para 3	2
US-34	Void Para 4	4
US-35	Void Para 5	5
US-36	Void Para 6	1000

Code	Name	Setting
US-37	Void Para 7	3000
US-38	Void Para 8	6000
IN-65	P1 Define	1: FX
IN-66	P2 Define	2: RX
IN-68	P4 Define	7: Sp-L
IN-69	P5 Define	8: Sp-M

Code	Name	Setting
UF-01	User Func 1	21: BITTEST
UF-02	User Input 1-A	155A
UF-03	User Input 1-B	1D22
UF-04	User Input 1-C	-
UF-15	User Output 1	-

Code	Name	Setting
UF-06	User Func 2	21: BITTEST
UF-07	User Input 2-A	155A
UF-08	User Input 2-B	1D23
UF-09	User Input 2-C	-
UF-10	User Output 2	-

Code	Parameter	Setting
DR-06	Cmd Source	1:Fx/Rx-1
DR-07	Freq Ref Src	0:Keypad-1

Continued to next page

II. Advanced Examples

Example 6 – Multi-speed Operation with DI (3)

● 6-3. Parameter setting (2)

✓ Comm. addresses: Out1: 1E05 / Out2: 1E0A / Out3: 1E0F / Out4: 1E14 / Out5: 1E19 / Out6: 1E1E / Out7: 1E23

Code	Name	Setting
UF-06	User Func 3	21:MPYDIV
UF-07	User Input 3-A	1E0A
UF-08	User Input 3-B	1D21
UF-09	User Input 3-C	1D20
UF-10	User Output 3	-

Code	Name	Setting
UF-11	User Func 4	1:ADD
UF-12	User Input 4-A	1E05
UF-13	User Input 4-B	1E0F
UF-14	User Input 4-C	-
UF-15	User Output 4	-

Code	Name	Setting
UF-16	User Func 5	12:Compare-EQ
UF-17	User Input 5-A	1E14
UF-18	User Input 5-B	1D1F
UF-19	User Input 5-C	1D24
UF-20	User Output 5	-

Code	Name	Setting
UF-21	User Func 6	12:Compare-EQ
UF-22	User Input 6-A	1E14
UF-23	User Input 6-B	1D20
UF-24	User Input 6-C	1D25
UF-25	User Output 6	

Code	Name	Setting
UF-26	User Func 7	12:Compare-EQ
UF-27	User Input 7-A	1E14
UF-28	User Input 7-B	1D21
UF-29	User Input 7-C	1D26
UF-30	User Output 7	-

Code	Name	Setting
UF-31	User Func 8	5:MAX
UF-32	User Input 8-A	1E19
UF-33	User Input 8-B	1E1E
UF-34	User Input 8-C	1E23
UF-35	User Output 8	-

Continued to next page

II. Advanced Examples

Example 6 – Multi-speed Operation with DI (4)

● 6-4. Results

- ✓ Results: At the beginning, command frequency is 10Hz. After inputting Speed-L or Speed-M signal, step is determined by difference between the number of inputting Speed-L and Speed-M.
- ✓ Practice: Try to add more steps with one more Speed-H, Compare-Equal, MAX blocks

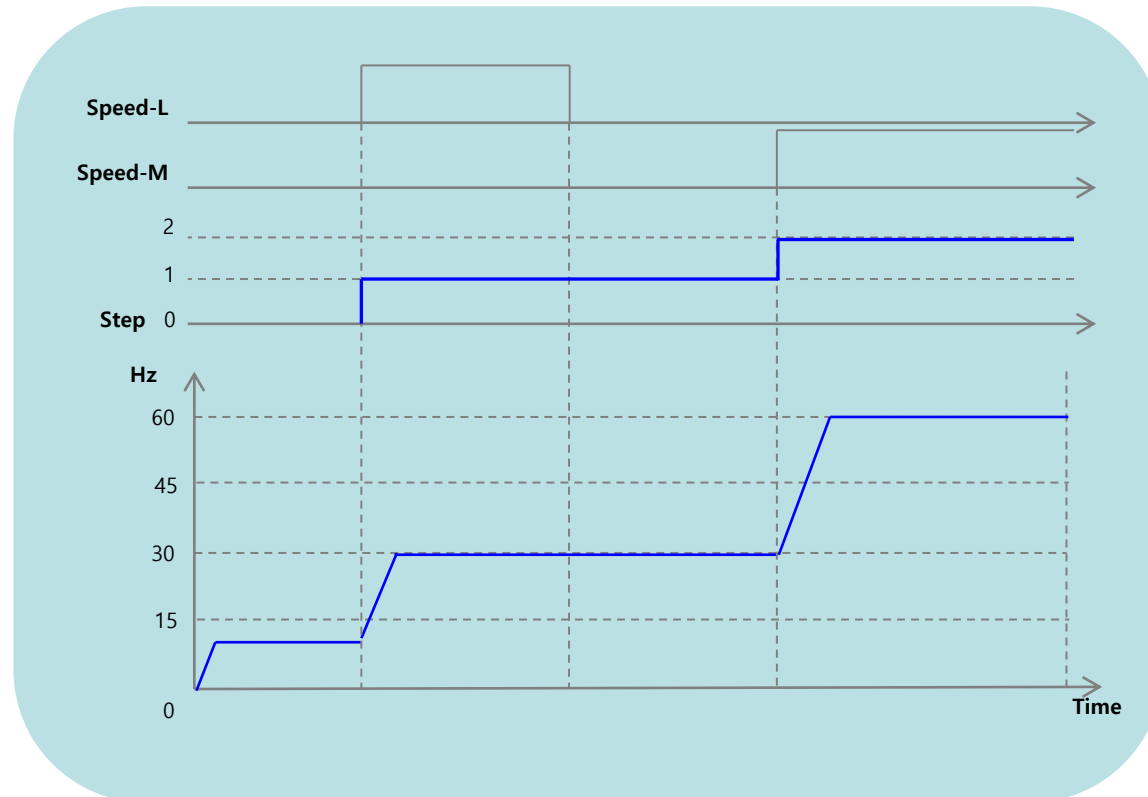

II. Advanced Examples

Example 7 – Torque boost control through PI control (1)

● 7-1. Outline

- ✓ You can adjust the parameter through PI controller at the difference between command and output.
- ✓ Used function block: SUB, ABS, MPYDIV, PI-Control, PI-Process

● 7-2. Diagram

- ✓ In this example, if there is a difference between set value and output, increase forward torque boost value.

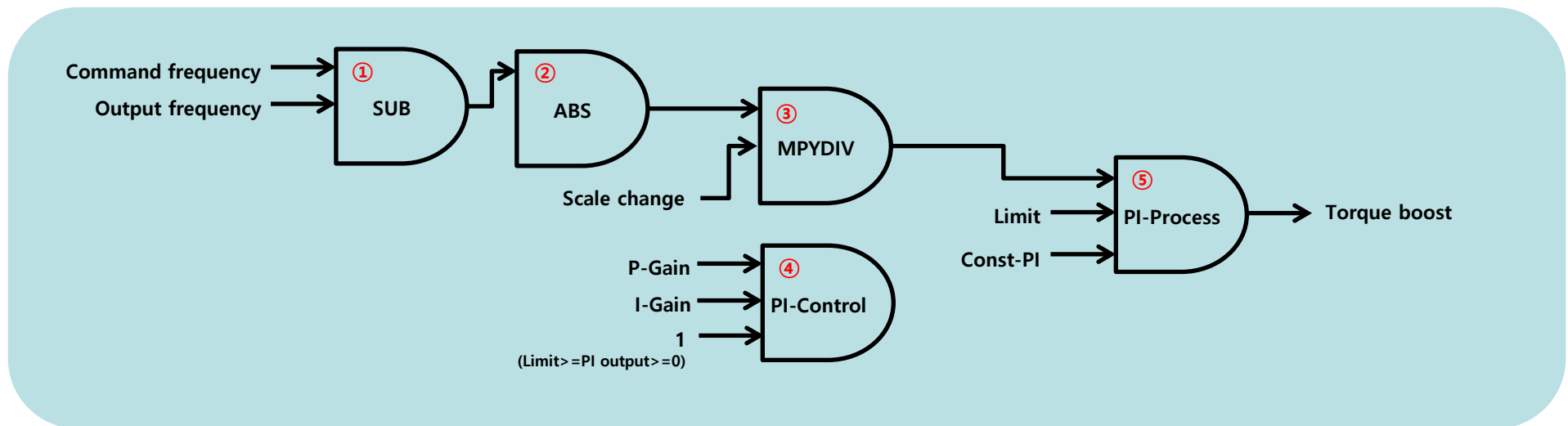

Continued to next page

II. Advanced Examples

Example 7 – Torque boost control through PI control (2)

● 7-3. Parameter setting (1)

Comm. Addresses

✓ Command frequency:1101, Output frequency: 000A, Out1: 1E05

Code	Name	Setting
OU-01	A01 mode	0: Freq
APP-02	User Seq. En	1 : Yes
US-02	User Seq. Loop Time	5: 1.0S
US-18	Link User Out 8	1101
US-01	User Seq. Con	0 : Stop

Code	Name	Setting
US-31	Void Para 1	100
US-32	Void Para 2	10
US-33	Void Para 3	2
US-34	Void Para 4	150
US-35	Void Para 5	1

Code	Name	Setting
UF-01	User Func 1	2: SUB
UF-02	User Input 1-A	1101
UF-03	User Input 1-B	000A
UF-04	User Input 1-C	-
UF-15	User Output 1	-

Code	Name	Setting
UF-06	User Func 2	6: ABS
UF-07	User Input 2-A	1E05
UF-08	User Input 2-B	-
UF-09	User Input 2-C	-
UF-10	User Output 2	-

Continued to next page

II. Advanced Examples

Example 7 – Torque boost control through PI control (3)

● 7-3. Parameter setting (2)

Comm. Addresses

✓ Out1: 1E05 / Out2: 1E0A / Out3: 1E0F / Out4: 1E14 / Out5: 1E19 / Out6: 1E1E / Out7: 1E23

Code	Name	Setting
UF-06	User Func 3	9: MPYDIV
UF-07	User Input 3-A	1E0A
UF-08	User Input 3-B	1D23
UF-09	User Input 3-C	1D20
UF-10	User Output 3	-

Code	Name	Setting
UF-11	User Func 4	25: PI- CONTROL
UF-12	User Input 4-A	1D1F
UF-13	User Input 4-B	1D20
UF-14	User Input 4-C	1D21
UF-15	User Output 4	-

Code	Name	Setting
UF-16	User Func 5	26: PI- PROCESS
UF-17	User Input 5-A	1E0F
UF-18	User Input 5-B	1D23
UF-19	User Input 5-C	1D0E
UF-20	User Output 5	-

● 7-4. Results

✓ Results:

- During forward operation, in the V/F mode, if there is a frequency difference between set value and output, forward torque boost value increases. But, Dr.15 must be manual.

- If there is 10Hz of difference, P gain should be 100 and I gain should be 10. but, since the unit scale of torque boost is 0.1, P gain is 10 in the first loop of the operation.

- If there is no difference, torque boost decreases to 0%.

✓ Practice: Try to make another compensation control logic using different values

II. Advanced Examples

Example 8 – Sequence using virtual DI (1)

● 8-1. Outline

- ✓ Multi-speed/multi-acc,dec operation can be possible by using virtual DI.
- ✓ Used function block: Compare-EQ, Compare-NEQ, XOR, REMAINDER, SWITCH, UPCOUNT

● 8-2. Diagram

- ✓ In this example, you can use virtual DI to change speed and acc, Dec time when speed reaches at the preset speed.
- ✓ Until it stopped, Operation continued in regular sequence.

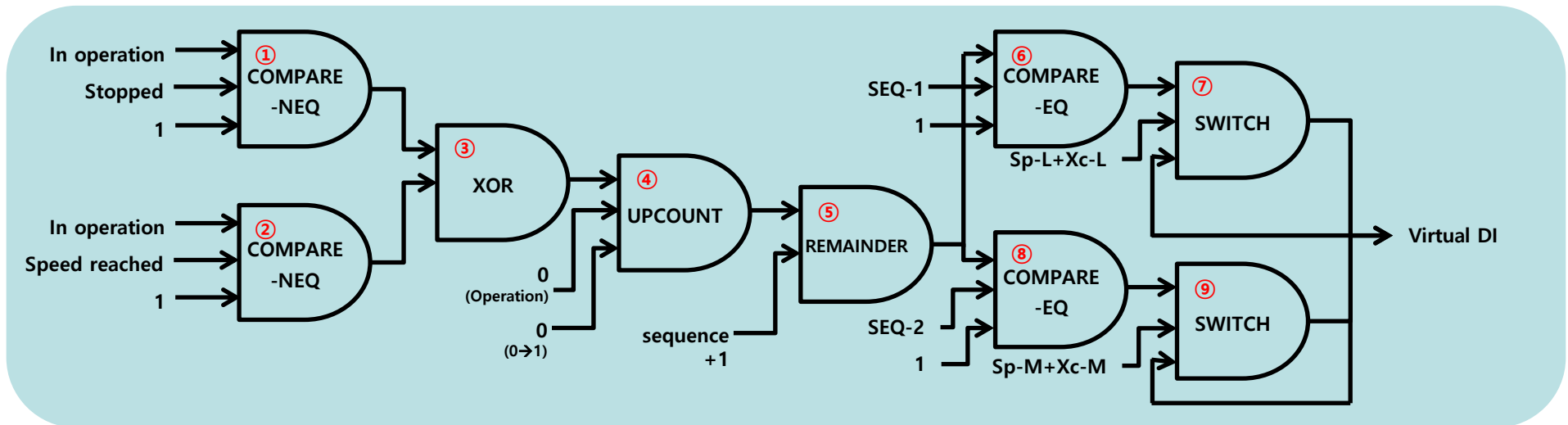

Continued to next page

II. Advanced Examples

Example 8 – Sequence using virtual DI (2)

● 8-3. Parameter setting (1)

Comm. addresses

✓ Operation status: 000E / Virtual digital input: 0385

Operation status analysis

✓ Stop: 1 / Speed arrival: 2114 / Accelerating: 2066 / Stopping: 258

Code	Name	Setting
OU-01	A01 mode	0: Freq
APP-02	User Seq. En	1 : Yes
US-02	User Seq. Loop Time	5: 1.0S
US-17	Link User Out 7	0385
US-19	Link User Out 9	0385
US-01	User Seq. Con	0 : Stop

Code	Name	Setting
CM-70	Virtual DI 1	7: Sp-L
CM-71	Virtual DI 2	8: Sp-M
CM-72	Virtual DI 3	11:Xcel-L
CM-73	Virtual DI 4	12:Xcel-M

Code	Name	Setting
US-31	Void Para 1	0
US-32	Void Para 2	1
US-33	Void Para 3	2114
US-34	Void Para 4	5
US-35	Void Para 5	10
US-36	Void Para 6	2
US-37	Void Para 7	3

Code	Name	Setting
DR-01	Cmd Freq	5Hz
DR-02	Acc Time	10Sec
DR-03	Dec Time	10Sec
BA-50	Step Freq 1	10Hz
BA-51	Step Freq 2	20Hz
BA-70	Acc Time 1	5Sec
BA-71	Dec Time 1	5Sec
BA-72	Acc Time 2	3Sec
BA-73	Dec Time 2	3Sec

Continued to next page

II. Advanced Examples

Example 8 – Sequence using virtual DI(3)

● 8-3. Parameter setting (2)

✓ Comm. addresses: Out1: 1E05 / Out2: 1E0A / Out3: 1E0F / Out4: 1E14 / Out5: 1E19 / Out6: 1E1E / Out7: 1E23 / Out8: 1E28 / Out9: 1E2D

Code	Name	Setting
UF-01	User Func 1	13:Compare-NEQ
UF-02	User Input 1-A	000E
UF-03	User Input 1-B	1D20
UF-04	User Input 1-C	1D20
UF-15	User Output 1	-

Code	Name	Setting
UF-06	User Func 2	13:Compare-NEQ
UF-07	User Input 2-A	000E
UF-08	User Input 2-B	1D21
UF-09	User Input 2-C	1D20
UF-10	User Output 2	-

Code	Name	Setting
UF-06	User Func 3	18: XOR
UF-07	User Input 3-A	1E05
UF-08	User Input 3-B	1E0A
UF-09	User Input 3-C	-
UF-10	User Output 3	-

Code	Name	Setting
UF-11	User Func 4	27:UPCOUNT
UF-12	User Input 4-A	1E0F
UF-13	User Input 4-B	1D1F
UF-14	User Input 4-C	1D20
UF-15	User Output 4	-

Code	Name	Setting
UF-16	User Func 5	6:REMAINDER
UF-17	User Input 5-A	1E14
UF-18	User Input 5-B	1D25
UF-19	User Input 5-C	-
UF-20	User Output 5	-

Code	Name	Setting
UF-21	User Func 6	12:Compare-EQ
UF-22	User Input 6-A	1E19
UF-23	User Input 6-B	1D20
UF-24	User Input 6-C	1D20
UF-25	User Output 6	-

Continued to next page

II. Advanced Examples

Example 8 – Sequence using virtual DI(4)

● 8-3. Parameter setting (2)

✓ Comm. addresses: Out1: 1E05 / Out2: 1E0A / Out3: 1E0F / Out4: 1E14 / Out5: 1E19 / Out6: 1E1E / Out7: 1E23 / Out8: 1E28 / Out9: 1E2D

Code	Name	Setting
UF-26	User Func 7	20:SWITCH
UF-27	User Input 7-A	1E1E
UF-28	User Input 7-B	1D22
UF-29	User Input 7-C	0385
UF-30	User Output 7	-

Code	Name	Setting
UF-31	User Func 8	12:Compare-EQ
UF-32	User Input 8-A	1E19
UF-33	User Input 8-B	1D24
UF-34	User Input 8-C	1D20
UF-35	User Output 8	-

Code	Name	Setting
UF-36	User Func 9	20:SWITCH
UF-37	User Input 9-A	1E28
UF-38	User Input 9-B	1D23
UF-39	User Input 9-C	0385
UF-40	User Output 9	-

● 8-4. Results

- ✓ Results: If AC drive and user sequence is operated, it accelerate to 5Hz in 0.8 sec(=10Sec/60HzX5Hz).
When it reached the 5Hz, it goes to SEQ-1 operation and accelerate to 10Hz in 0.4 sec(=5Sec/60HzX5Hz).
When it reached the 10Hz, it continue to execution of SEQ-2 and accelerate to 20Hz in 0.25 sec(=3Sec/60HzX5Hz).
When it reached the 20Hz, it goes to basic-step operation and speed decreases to 5Hz in 2.5 sec(=10Sec/60HzX15Hz).
- ✓ Practice: Try to test with different values of DR-01~03, BA-50~73
Try to make additional sequence using Compare-EQ and SWITCH

II. Advanced Examples

Example 9 – Automatic Speed Change

● 9-1. Outline

- ✓ After RUN signal, Drive runs and changes the output speed automatically
- ✓ Required Function Blocks : BITTEST, SWITCH, TIMER, UPCOUNT, REMAINDER, COMPARE-EQ, MAX

● 9-2. Diagram

- ✓ With this sequence diagram, Drive runs and changes output speed according to pre-programmed time

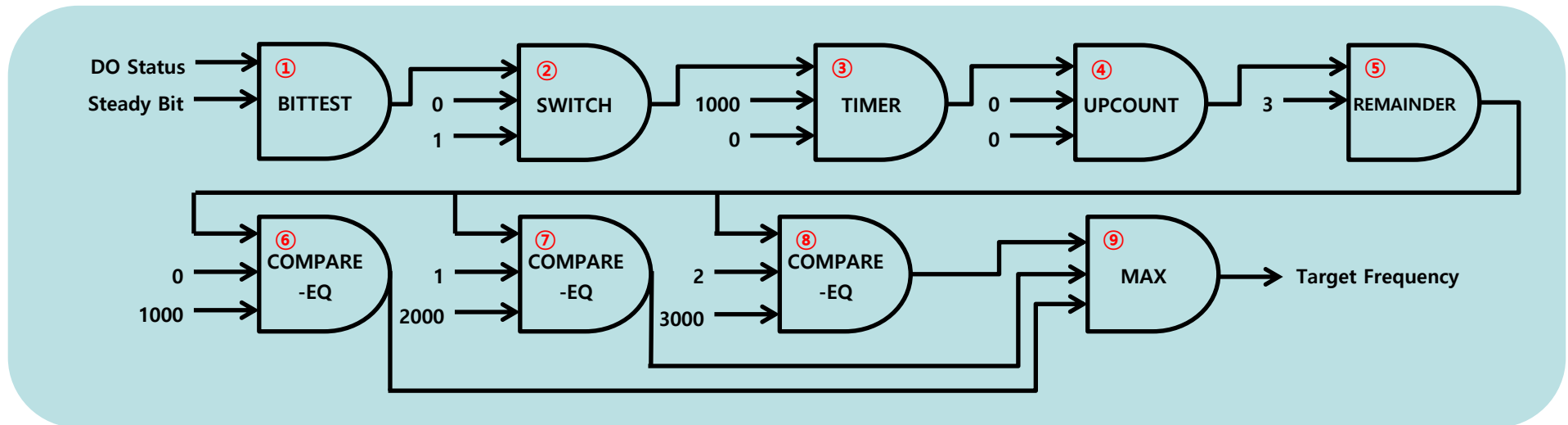

II. Advanced Examples

Example 9 – Automatic Speed Change

● 9-3. Parameter Setting (1)

✓ Comm. Address : Out1: 1E05 / Out2: 1E0A / Out3: 1E0F / Out4: 1E14 / Out5: 1E19 / Out6: 1E1E / Out7: 1E23 / Out8: 1E28

Code	Parameter	Setting
OU-31	Relay1	16:Steady
APP-02	User Seq. En	1 : Yes
US-02	User Seq. Loop Time	1: 0.02S
US-19	Link User Out 9	1101
US-01	User Seq. Con	0 : Stop

Code	Parameter	Setting
DR-06	Cmd Source	1:Fx/Rx-1
DR-07	Freq Ref Src	0:Keypad-1

Code	Parameter	Setting
US-31	Void Para 1	0
US-32	Void Para 2	1
US-33	Void Para 3	2
US-34	Void Para 4	3
US-35	Void Para 5	1000
US-36	Void Para 6	2000
US-37	Void Para 7	3000
US-38	Void Para 8	100

Code	Parameter	Setting
UF-01	User Func 1	21: BIITTEST
UF-02	User Input 1-A	1629
UF-03	User Input 1-B	1
UF-04	User Input 1-C	-
UF-15	User Output 1	-

Code	Parameter	Setting
UF-06	User Func 2	20:SWIT CH
UF-07	User Input 2-A	1E05
UF-08	User Input 2-B	1D1F
UF-09	User Input 2-C	1D20
UF-10	User Output 2	-

II. Advanced Examples

Example 9 – Automatic Speed Change

● 9-3. Parameter Setting (2)

✓ Comm. Address : Out1: 1E05 / Out2: 1E0A / Out3: 1E0F / Out4: 1E14 / Out5: 1E19 / Out6: 1E1E / Out7: 1E23 / Out8: 1E28

Code	Parameter	Setting
UF-06	User Func 3	14:TIMER
UF-07	User Input 3-A	1D26
UF-08	User Input 3-B	1E0A
UF-09	User Input 3-C	1D1F
UF-10	User Output 3	-

Code	Parameter	Setting
UF-11	User Func 4	27:UP-COUNT
UF-12	User Input 4-A	1E0F
UF-13	User Input 4-B	1D1F
UF-14	User Input 4-C	1D1F
UF-15	User Output 4	-

Code	Parameter	Setting
UF-16	User Func 5	8:REMAINDER
UF-17	User Input 5-A	1E14
UF-18	User Input 5-B	1D22
UF-19	User Input 5-C	-
UF-20	User Output 5	-

Code	Parameter	Setting
UF-21	User Func 6	12:Compare-EQ
UF-22	User Input 6-A	1E19
UF-23	User Input 6-B	1D1F
UF-24	User Input 6-C	1D23
UF-25	User Output 6	-

Code	Parameter	Setting
UF-26	User Func 7	12:Compare-EQ
UF-27	User Input 7-A	1E19
UF-28	User Input 7-B	1D20
UF-29	User Input 7-C	1D24
UF-30	User Output 7	-

Code	Parameter	Setting
UF-31	User Func 8	12:Compare-EQ
UF-32	User Input 8-A	1E19
UF-33	User Input 8-B	1D21
UF-34	User Input 8-C	1D25
UF-35	User Output 8	-

II. Advanced Examples

Example 9 – Automatic Speed Change

● 9-3. Parameter Setting (3)

✓ Comm. Address : Out1: 1E05 / Out2: 1E0A / Out3: 1E0F / Out4: 1E14 / Out5: 1E19 / Out6: 1E1E / Out7: 1E23 / Out8: 1E28

Code	Parameter	Setting
UF-36	User Func 9	5:MAX
UF-37	User Input 9-A	1E1E
UF-38	User Input 9-B	1E23
UF-39	User Input 9-C	1E28
UF-40	User Output 9	-

● 9-4. Result

- ✓ Result: Target frequency changes every 2 seconds in this order 10Hz→20Hz→30Hz→10Hz→20Hz.....
- ✓ Practice: Try to make the target frequency change faster or slower with different values of US-02 x US-38)

II. Advanced Examples

Example 10 – Automatic Speed + Acc/Dec Time change

● 10-1. Outline

- ✓ After RUN signal, Drive changes Target Freq. and Acc. Time automatically
- ✓ Required function block : MPYDIV, BITTEST, SWITCH, TIMER, UPCOUNT, REMAINDER, COMPARE-GT, COMPARE-EQ, MAX

● 10-2. Diagram

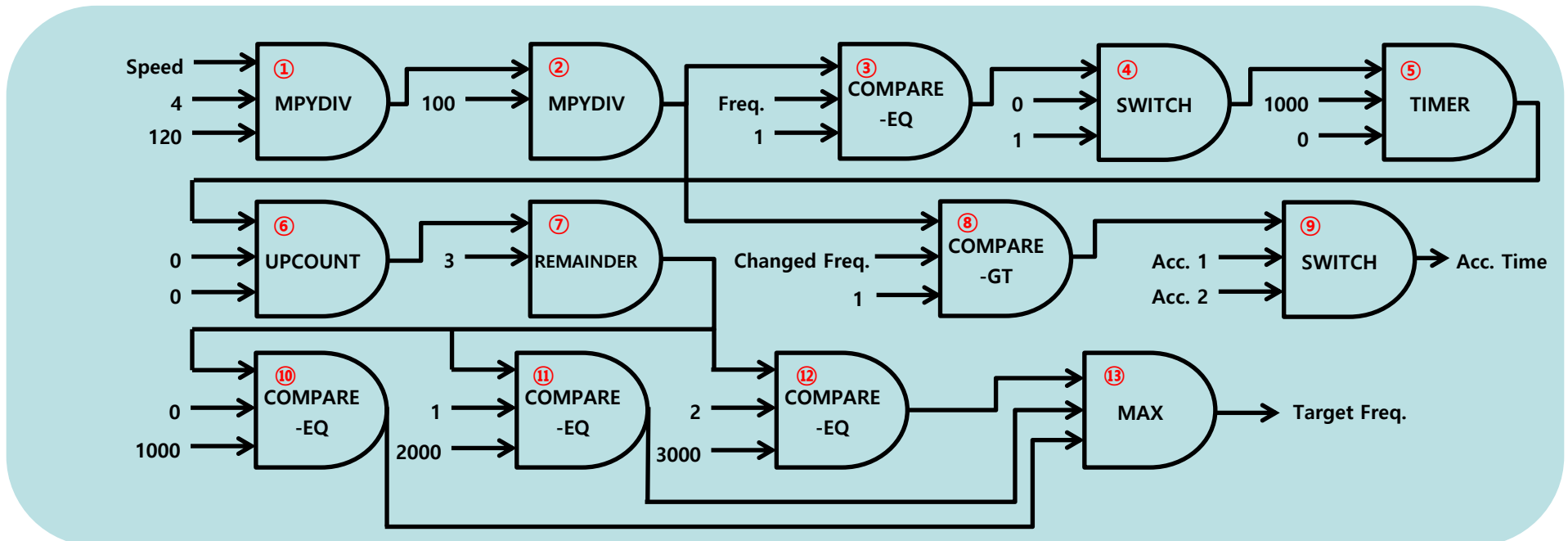

II. Advanced Examples

Example 10 – Automatic Speed + Acc/Dec Time change

● 10-3. Parameter Setting (1)

✓ Required Address: SPS-Speed: 1F09 / Pole number: 120B

Code	Parameter	Setting
OU-31	Relay1	16:Steady
APP-02	User Seq. En	1 : Yes
US-02	User Seq. Loop Time	1: 0.02S
US-19	Link User Out 9	1103
US-23	Link User Out 13	1101
US-01	User Seq. Con	0 : Stop

Code	Parameter	Setting
DR-06	Cmd Source	1:Fx/Rx-1
DR-07	Freq Ref Src	0:Keypad-1

Code	Parameter	Setting
US-31	Void Para 1	0
US-32	Void Para 2	1
US-33	Void Para 3	2
US-34	Void Para 4	3
US-35	Void Para 5	100
US-36	Void Para 6	120
US-37	Void Para 7	200
US-38	Void Para 8	2000
US-39	Void Para 9	4000
US-40	Void Para 10	6000
US-41	Void Para 11	3000

Code	Parameter	Setting
UF-01	User Func 1	9:MPYDIV
UF-02	User Input 1-A	1F09
UF-03	User Input 1-B	120B
UF-04	User Input 1-C	1D24
UF-15	User Output 1	-

Code	Parameter	Setting
UF-06	User Func 2	9:MPYDIV
UF-07	User Input 2-A	1E05
UF-08	User Input 2-B	1D23
UF-09	User Input 2-C	-
UF-10	User Output 2	-

II. Advanced Examples

Example 10 – Automatic Speed + Acc/Dec Time change

● 10-3. Parameter Setting (2)

✓ Required Address : Out1: 1E05 / Out2: 1E0A / Out3: 1E0F / Out4: 1E14 / Out5: 1E19 / Out6: 1E1E / Out7: 1E23 / Out8: 1E28

Code	Parameter	Setting
UF-06	User Func 3	12:Compare-EQ
UF-07	User Input 3-A	1E0F
UF-08	User Input 3-B	1101
UF-09	User Input 3-C	1D20
UF-10	User Output 3	-

Code	Parameter	Setting
UF-11	User Func 4	20:SWITCH
UF-12	User Input 4-A	1E0F
UF-13	User Input 4-B	1D1F
UF-14	User Input 4-C	1D20
UF-15	User Output 4	-

Code	Parameter	Setting
UF-16	User Func 5	14:TIMER
UF-17	User Input 5-A	1D25
UF-18	User Input 5-B	1E14
UF-19	User Input 5-C	1D1F
UF-20	User Output 5	-

Code	Parameter	Setting
UF-21	User Func 6	27:UP-COUNT
UF-22	User Input 6-A	1E19
UF-23	User Input 6-B	1D1F
UF-24	User Input 6-C	1D1F
UF-25	User Output 6	-

Code	Parameter	Setting
UF-26	User Func 7	8:REMAINDER
UF-27	User Input 7-A	1E1E
UF-28	User Input 7-B	1D22
UF-29	User Input 7-C	-
UF-30	User Output 7	-

Code	Parameter	Setting
UF-31	User Func 8	10:Compare-GT
UF-32	User Input 8-A	1E0A
UF-33	User Input 8-B	1D29
UF-34	User Input 8-C	1D20
UF-35	User Output 8	-

II. Advanced Examples

Example 10 – Automatic Speed + Acc/Dec Time change

● 10-3. Parameter Setting (3)

✓ 통신번지: Out1: 1E05 / Out2: 1E0A / Out3: 1E0F / Out4: 1E14 / Out5: 1E19 / Out6: 1E1E / Out7: 1E23 / Out8: 1E28 / Out9: 1E2D

Code	Parameter	Setting
UF-36	User Func 9	20:SWITC H
UF-37	User Input 9-A	1E28
UF-38	User Input 9-B	1D23
UF-39	User Input 9-C	1D25
UF-40	User Output 9	-

Code	Parameter	Setting
UF-41	User Func 10	12:Comp are-EQ
UF-42	User Input 10-A	1E23
UF-43	User Input 10-B	1D1F
UF-44	User Input 10-C	1D26
UF-45	User Output 10	-

Code	Parameter	Setting
UF-46	User Func 11	12:Comp are-EQ
UF-47	User Input 11-A	1E23
UF-48	User Input 11-B	1D20
UF-49	User Input 11-C	1D27
UF-50	User Output 11	-

Code	Parameter	Setting
UF-51	User Func 12	12:Comp are-EQ
UF-52	User Input 12-A	1E23
UF-53	User Input 12-B	1D21
UF-54	User Input 12-C	1D28
UF-55	User Output 12	-

Code	Parameter	Setting
UF-56	User Func 13	5:MAX
UF-57	User Input 13-A	1D32
UF-58	User Input 13-B	1D37
UF-59	User Input 13-C	1D3C
UF-60	User Output 13	-

● 8-4. Result

✓ Target Freq. changes every 4 seconds in this order 20Hz→40Hz→60Hz→20Hz→(.....). Acc. Time becomes 20sec before 30Hz and 10sec after 30Hz. Try to change US-02, US-73 for different cycle and changes US-35, 37 for different acc. Time.

The end

Attach. Major communication addresses

S100 Major parameter communication addresses

Address (Hex)	Parameter	Unit	Scale
1101	Target Freq.	Hz	0.01
1103	Acc Time	Sec	0.1
1104	Dec Time	Sec	0.1
1505	Analog Input 1	%	0.01
1606	Analog Output 1	%	0.1
155A	Multi-func. Input Status	Bit	-
0385	Virtual Multi-func. Input	Bit	-
1629	Multi-func. Output Status	Bit	-
1404	Carrier Freq.	kHz	0.1
0009	Output Current	A	0.1
000A	Output Freq.	Hz	0.01
000B	Output Volt.	V	1
000C	DC-link Volt.	V	1
000D	Output Power	kW	0.1
000E	Operation Status	-	-
000F	Fault Info.	-	-

Address (Hex)	Parameter
1D1F	Void Para 1
1D20	Void Para 2
1D21	Void Para 3
1D22	Void Para 4
1D23	Void Para 5
1D24	Void Para 6
1D25	Void Para 7
1D26	Void Para 8
1D27	Void Para 9
1D28	Void Para 10
1D29	Void Para 11
1D30	Void Para 12
1E05	User Output 1
1E0A	User Output 2
1E0F	User Output 3
1E14	User Output 4

Address (Hex)	Parameter
1E19	User Output 5
1E1E	User Output 6
1E23	User Output 7
1E28	User Output 8
1E2D	User Output 9
1E32	User Output 10
1E37	User Output 11
1E3C	User Output 12
1E41	User Output 13
1E46	User Output 14
1E4B	User Output 15
1E50	User Output 16
1E55	User Output 17
1E0A	User Output 18
1E55	User Output 17
1E0A	User Output 18