

The right choice for the ultimate yield!

LS ELECTRIC strives to maximize your profits in gratitude for choosing us as your partner.

## Programmable Logic Control

# Analog Input Module

**XGT Series**

**User Manual**

**XGF-AD8A**



### Safety Instructions

- Read this manual carefully before installing, wiring, operating, servicing or inspecting this equipment.
- Keep this manual within easy reach for quick reference.

**LS** ELECTRIC

### Before using the product ...

For your safety and effective operation, please read the safety instructions thoroughly before using the product.

- ▶ Safety Instructions should always be observed in order to prevent accident or risk with the safe and proper use the product.
- ▶ Instructions are divided into “Warning” and “Caution”, and the meaning of the terms is as follows.



This symbol indicates the user is expected risk of death or serious injury in case of incorrect handling



This symbol indicates the user is expected risk of injury or property damage only in case of incorrect handling

Moreover, even classified events under its caution category may develop into serious accidents relying on situations. Therefore we strongly advise users to observe all precautions properly just like warnings.

- ▶ The marks displayed on the product and in the user’s manual have the following meanings.

 Be careful! Danger may be expected.

 Be careful! Electric shock may occur.

- ▶ The user’s manual even after read shall be kept available and accessible to any user of the product.

## Safety Instructions for design process

### **Warning**

- ▶ **Please install a protection circuit on the exterior of PLC so that the whole system may operate safely regardless of failures from external power or PLC.** Any abnormal output or operation from PLC may cause serious problems to safety in whole system.
  - Install protection units on the exterior of PLC like an interlock circuit that deals with opposite operations such as emergency stop, protection circuit, and forward/reverse rotation or install an interlock circuit that deals with high/low limit under its position controls.
  - If any system error (watch-dog timer error, module installation error, etc.) is detected during CPU operation in PLC, all output signals are designed to be turned off and stopped for safety. However, there are cases when output signals remain active due to device failures in Relay and TR which can't be detected. Thus, you are recommended to install an addition circuit to monitor the output status for those critical outputs which may cause significant problems.
  
- ▶ **Never overload more than rated current of output module nor allow to have a short circuit.** Over current for a long period time may cause a fire.
  
- ▶ **Never let the external power of the output circuit to be on earlier than PLC power,** which may cause accidents from abnormal output or operation.
  
- ▶ **Please install interlock circuits in the sequence program for safe operations in the system when exchange data with PLC or modify operation modes using a computer or other external equipments** Read specific instructions thoroughly when conducting control operations with PLC.

## Safety Instructions for design process

### **Caution**

- ▶ **I/O signal or communication line shall be wired at least 100mm away from a high-voltage cable or power line.** Fail to follow this instruction may cause malfunctions from noise

## Safety Instructions on installation process

### **Caution**

- ▶ **Use PLC only in the environment specified in PLC manual or general standard of data sheet.** If not, electric shock, fire, abnormal operation of the product may be caused.
- ▶ **Before install or remove the module, be sure PLC power is off.** If not, electric shock or damage on the product may be caused.
- ▶ **Be sure that every module is securely attached after adding a module or an extension connector.** If the product is installed loosely or incorrectly, abnormal operation, error or dropping may be caused. In addition, contact failures under poor cable installation will be causing malfunctions as well.
- ▶ **Be sure that screws get tighten securely under vibrating environments.** Fail to do so will put the product under direct vibrations which will cause electric shock, fire and abnormal operation.
- ▶ **Do not come in contact with conducting parts in each module,** which may cause electric shock, malfunctions or abnormal operation.

## Safety Instructions for wiring process

### **Warning**

- ▶ **Prior to wiring works, make sure that every power is turned off.** If not, electric shock or damage on the product may be caused.
- ▶ **After wiring process is done, make sure that terminal covers are installed properly before its use.** Fail to install the cover may cause electric shocks.

### **Caution**

- ▶ **Check rated voltages and terminal arrangements in each product prior to its wiring process.** Applying incorrect voltages other than rated voltages and misarrangement among terminals may cause fire or malfunctions.
- ▶ **Secure terminal screws tightly applying with specified torque.** If the screws get loose, short circuit, fire or abnormal operation may be caused. Securing screws too tightly will cause damages to the module or malfunctions, short circuit, and dropping.
- \*
  - ▶ **Be sure to earth to the ground using Class 3 wires for PE terminals which is exclusively used for PLC.** If the terminals not grounded correctly, abnormal operation or electric shock may be caused.
  - ▶ **Don't let any foreign materials such as wiring waste inside the module while wiring,** which may cause fire, damage on the product or abnormal operation.
  - ▶ **Make sure that pressed terminals get tighten following the specified torque. External connector type shall be pressed or soldered using proper equipments.**

## Safety Instructions for test-operation and maintenance

### **Warning**

- ▶ **Don't touch the terminal when powered.** Electric shock or abnormal operation may occur.
- ▶ **Prior to cleaning or tightening the terminal screws, let all the external power off including PLC power.** If not, electric shock or abnormal operation may occur.
- ▶ **Don't let the battery recharged, disassembled, heated, short or soldered.** Heat, explosion or ignition may cause injuries or fire.

### **Caution**

- ▶ **Do not make modifications or disassemble each module.** Fire, electric shock or abnormal operation may occur.
- ▶ **Prior to installing or disassembling the module, let all the external power off including PLC power.** If not, electric shock or abnormal operation may occur.
- ▶ **Keep any wireless equipment such as walkie-talkie or cell phones at least 30cm away from PLC.** If not, abnormal operation may be caused.
- ▶ **When making a modification on programs or using run to modify functions under PLC operations, read and comprehend all contents in the manual fully.** Mismanagement will cause damages to products and accidents.
- ▶ **Avoid any physical impact to the battery and prevent it from dropping as well.** Damages to battery may cause leakage from its fluid. When battery was dropped or exposed under strong impact, never reuse the battery again. Moreover skilled workers are needed when exchanging batteries.

## Safety Instructions for waste disposal

 **Caution**

- ▶ **Product or battery waste shall be processed as industrial waste.** The waste may discharge toxic materials or explode itself.

# Revision History

| Version | Date   | Remark  | Revised position |
|---------|--------|---|------------------|
| V 1.0   | 2009.9 | 1. First Edition  | -                |
| V1.1    | 2014.1 | 1. View the variables/comments contents   | 4-18             |
|         |        | 2. Correct typing error   | Ch.2, Ch.5, Ch.6 |
|         |        | 3. Correct channel address error about setting output data range                                | Ch.7             |
| V1.2    | 2015.7 | 1. Domain address and CI changed  |                  |
|         |        | 2. General specifications changed by reason of changed IEC specifications                       | 2-1              |
| V1.5    | 2020.7 | 1. Format and contents modification according to the change of company name(LSIS → LS ELECTRIC) |                  |
| V1.6    | 2022.6 | 1. Add disconnection LED display function   | 2-4              |

Thank you for purchasing PLC of LS ELECTRIC Co., Ltd.

Before use, make sure to carefully read and understand the User's Manual about the functions, performances, installation and programming of the product you purchased in order for correct use and importantly, let the end user and maintenance administrator to be provided with the User's Manual.

The User's Manual describes the product. If necessary, you may refer to the following description and order accordingly. In addition, you may connect our website (<http://www.ls-electric.com/>) and download the information as a PDF file.

Relevant User's Manuals

| Title  | Description  |
|--|--|
| XG5000 User's Manual (for XGK, XGB)                  | XG5000 software user manual describing online function such as programming, print, monitoring, debugging by using XGK, XGB CPU   |
| XG5000 User's Manual (for XGI, XGR)                  | XG5000 software user manual describing online function such as programming, print, monitoring, debugging by using XGI, XGR CPU   |
| XGK/XGB Instructions & Programming User's Manual     | User's manual for programming to explain how to use instructions that are used PLC system with XGK, XGB CPU.   |
| XGI/XGR/XEC Instructions & Programming User's Manual | User's manual for programming to explain how to use instructions that are used PLC system with XGI, XGR, XEC CPU.  |
| XGK CPU User's Manual (XGK-CPUA/CPUE/CPUH/CPUS/CPUU) | XGK-CPUA/CPUE/CPUH/CPUS/CPUU user manual describing about XGK CPU module, power module, base, IO module, specification of extension cable and system configuration, EMC standard         |
| XGI CPU User's Manual (XGI-CPUU/CPUH/CPUS)           | XGI-CPUU/CPUH/CPUS user manual describing about XGI CPU module, power module, base, IO module, specification of extension cable and system configuration, EMC standard                   |
| XGR redundant series User's Manual                   | XGR- CPUH/F, CPUH/T user manual describing about XGR CPU module, power module, extension drive, base, IO module, specification of extension cable and system configuration, EMC standard |

The User's Manual is based on XGF-AD16A.

This manual is based on the following versions.

| Product name                     | OS version |
|----------------------------------|------------|
| XGK-CPUH, CPUS, CPUA, CPUE, CPUU | V2.1       |
| XGI-CPUU, CPUH, CPUS             | V2.2       |
| XGR-CPUH/F, CPUH/T               | V1.3       |
| XG5000(XG-PD)                    | V2.41      |

# © Table of Content ©

## Chapter 1 Overview ..... 1-1 ~ 1-4

- 1.1 Characteristics ..... 1-1
- 1.2 Glossary ..... 1-2
  - 1.2.1 Analog Quantity - A ..... 1-2
  - 1.2.2 Digital Quantity - D ..... 1-2
  - 1.2.3 The Characteristics of Analog-Digital Conversion ..... 1-3
- 1.3 New Functions ..... 1-4

## Chapter 2 Specification ..... 2-1 ~ 2-20

- 2.1 General Specifications ..... 2-1
- 2.2 Performance Specifications ..... 2-2
- 2.3 Description of the Parts ..... 2-4
- 2.4 Characteristics of Input/Output Conversion ..... 2-5
  - 2.4.1 Input/Output Characteristics of XGF-AD8A ..... 2-6
  - 2.4.2 Precision ..... 2-13
- 2.5 Functions of the Analog Input Module ..... 2-14
  - 2.5.1 Sampling Processing ..... 2-14
  - 2.5.2 Average Processing ..... 2-15
  - 2.5.3 Detection of Input Disconnection ..... 2-17
  - 2.5.4 Hold last value (Dedicated for current input) ..... 2-19
  - 2.5.5 Alarm function ..... 2-19

## Chapter 3 Installation and Wiring ..... 3-1 ~ 3-4

- 3.1 Installation ..... 3-1
  - 3.1.1 Installation Environment ..... 3-1
  - 3.1.2 Precautions in Handling ..... 3-1
- 3.2 Wiring ..... 3-2

|                                   |     |
|-----------------------------------|-----|
| 3.2.1 Precautions in Wiring ..... | 3-2 |
| 3.2.2 An Example of Wiring .....  | 3-2 |

|  |                   |
|--|-------------------|
| <b>Chapter 4 Operating Setting .....</b> | <b>4-1 ~ 4-17</b> |
|--|-------------------|

|  |      |
|--|------|
| 4.1 The Operating Setting Flowchart .....          | 4-1  |
| 4.2 Operating Parameter Setting .....              | 4-2  |
| 4.2.1 Setting Items .....                          | 4-2  |
| 4.2.2 How to Use [I/O Parameter] .....             | 4-2  |
| 4.3 Functions of the Special Module Monitor .....  | 4-6  |
| 4.4 Precautions .....                              | 4-7  |
| 4.5 How to Use the Special Module Monitor .....    | 4-8  |
| 4.5.1 Starting [Special module monitoring] .....   | 4-8  |
| 4.5.2 How to Use [Special module monitoring] ..... | 4-8  |
| 4.6 U Automatic Registration of U Device .....     | 4-12 |
| 4.6.1 Automatic Registration of U Device .....     | 4-12 |
| 4.6.2 Saving Variables .....                       | 4-14 |
| 4.6.3 Viewing Variables in the Program .....       | 4-15 |

|   |                   |
|---|-------------------|
| <b>Chapter 5 Configuration and Functions of Internal Memory (For XGK) .....</b> | <b>5-1 ~ 5-11</b> |
|---|-------------------|

|   |     |
|---|-----|
| 5.1 The Configuration of the Internal Memory .....        | 5-1 |
| 5.1.1 Input and Output Areas of A/D Conversion Data ..... | 5-1 |
| 5.1.2 Operating Parameter Setting Range .....             | 5-3 |
| 5.2 A/D Conversion Data Input/Output Ranges .....         | 5-4 |
| 5.2.1 Module READY/ERROR Flag .....                       | 5-4 |
| 5.2.2 Operating channel flag .....                        | 5-4 |
| 5.2.3 Digital output value .....                          | 5-5 |
| 5.2.4 Disconnection detection flag .....                  | 5-5 |
| 5.2.5 Error clear request flag .....                      | 5-5 |
| 5.3 Operating Parameter Setting Ranges .....              | 5-6 |
| 5.3.1 Designation of the channel to use .....             | 5-6 |
| 5.3.2 Output Voltage/Current Ranges .....                 | 5-7 |
| 5.3.3 Output Data Ranges .....                            | 5-7 |

5.3.4 Average Processing ..... 5-8

5.3.5 Average Value ..... 5-8

5.3.6 Error Code ..... 5-10

5.3.7 Hold last value ..... 5-11

**Chapter 6 Programming (For XGK) ..... 6-1 ~ 6-7**

6.1 The Basic Program ..... 6-1

    6.1.1 An Example of a Program That Uses [I/O Parameter] ..... 6-1

    6.1.2 An Example of a Program That Uses the PUT/GET Command ..... 6-2

6.2 Application Program (XGK) ..... 6-3

    6.2.1 The Program Distinguishing A/D Conversion Values ..... 6-3

    6.2.2 The Program That Outputs the Error Code of the Analog Input Module through BCD Display ..... 6-6

**Chapter 7 Configuration and Functions of Global Variable (For XGI/XGR) ..... 7-1 ~ 7-17**

7.1 Global Variables (Data Areas)..... 7-1

    7.1.1 Configuration of A/D Conversion Data Input and Output Area ..... 7-1

    7.1.2 How to Use Global Variables ..... 7-2

7.2 PUT/GET Function Block Area (Parameter Area)..... 7-10

    7.2.1 PUT/GET Function Block Area (Parameter Area) ..... 7-10

    7.2.2 PUT/GET Commands ..... 7-11

    7.2.3 Examples of Use of PUT/GET Commands ..... 7-13

**Chapter 8 Programming (For XGI/XGR) ..... 8-1 ~ 8-9**

8.1 The Basic Program (XGI/XGR) ..... 8-1

    8.1.1 An Example of a Program That Uses [I/O Parameter] ..... 8-1

    8.1.2 An Example of a Program That Uses the PUT/GET Command ..... 8-3

8.2 Application Program (XGI/XGR) ..... 8-5

    8.2.1 The Program Distinguishing A/D Conversion Values ..... 8-5

    8.2.2 The Program That Outputs the Error Code of the Analog Input Module through BCD Display ..... 8-8

|   |           |
|---|-----------|
| Chapter 9 Failure Check .....   | 9-1 ~ 9-5 |
| 9.1 Error Code .....  | 9-1       |
| 9.2 Failure Check .....   | 9-2       |
| 9.2.1 RUN LED Flashes .....   | 9-2       |
| 9.2.2 RUN LED is Off .....  | 9-3       |
| 9.2.3 CPU Module Cannot Read A/D Conversion Values .....                  | 9-3       |
| 9.2.4 The Analog Input Value Inconsistent with Digital Output Value. .... | 9-4       |
| 9.2.5 Hardware Failure of the Analog Input Module .....                   | 9-4       |
| 9.2.6 Check of Analog Input Module Status by XG5000 System Monitor .....  | 9-4       |

|                           |           |
|---------------------------|-----------|
| Appendix 1 Glossary ..... | A1-1~A1-2 |
|---------------------------|-----------|

|                            |      |
|----------------------------|------|
| Appendix 2 Dimension ..... | A2-1 |
|----------------------------|------|

|                                   |
|-----------------------------------|
| Warranty and Environmental Policy |
|-----------------------------------|

## Chapter 1 Overview

This manual describes the specifications, handling, and programming of the XGF-AD8A type analog/digital conversion module, which is used in combination with the CPU module of the XGT PLC series. XGF-AD8A is hereafter referred to as the analog input module. The analog input module is for converting the analog signals (voltage or current input) from a PLC external device into digital values of the signed 14 bit binary data.

### 1.1 Characteristics

- 1) Hybrid input processing  
8 channel current/voltage input can be processed in a single module.
- 2) High speed conversion  
Conversion can be conducted at a high speed of 250 $\mu$ s/channel.
- 3) High precision  
The conversion precision is  $\pm 0.2\%$ (surrounding temperature 25 $^{\circ}$ C  $\pm$  5 $^{\circ}$ C).
- 4) High resolution of 1/16000  
The resolution of the digital values can be set at 1/16000.
- 5) Operating parameter setting and monitoring by GUI(Graphical User Interface)  
The operating setting, which was conducted by commands, can be manipulated by using [I/O parameter setting] with improved user interface, which increased the user's convenience. You can reduce the sequence program by using I/O parameter setting. Furthermore, you can easily monitor the A/D converted values using [Special module monitor] function.
- 6) A variety of digital output data formats  
4 types of digital output data format are supported. The output type of the digital data can be defined as follows.
  - Unsigned value: 0 ~ 16000
  - Signed value: -8000 ~ 8000
  - Precise value: see Chapter 2.2.
  - Percentile value: 0 ~ 10000
- 7) Short circuit detection  
A short circuit of the input circuit can be detected when the analog input sign range of 4 ~ 20 mA, 1 ~ 5 V is used.

1.2 Glossary

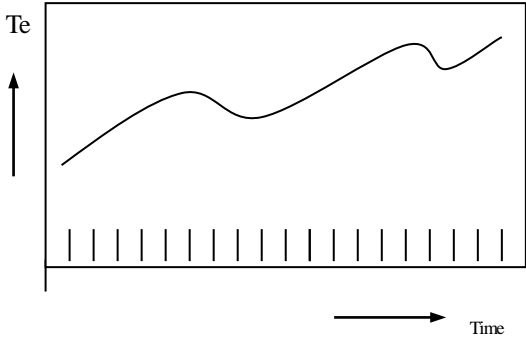

[Fig.1.1] Analog quantity

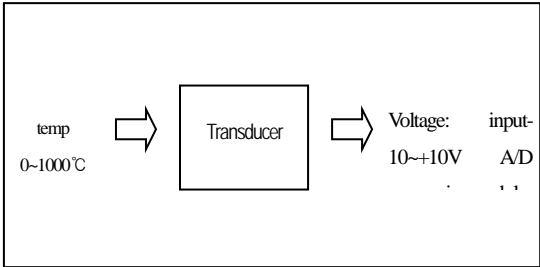

[Fig.1.2] An example of the transducer

1.2.1 Analog Quantity - A

Analog quantity refers to when a physical value is continuous. As analog values are unbroken, there is always a median value. Physical properties in general such as voltage, current, velocity, pressure and flow fall into the analog quantity. For example, the temperature is seamless over time as shown in Fig. 1.1 Because the temperature cannot be input directly into the Analog input module, it needs to be relayed by a transducer that converts input signals of analog properties into electrical signals.

1.2.2 Digital Quantity - D

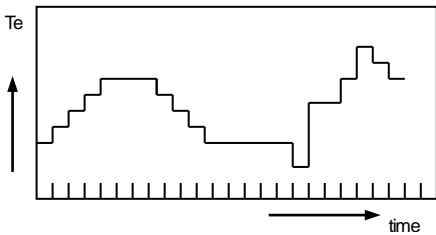

The data consisting of integers or the physical properties in figures are referred to as digital properties (Fig. 1.3). The digital properties are the electronic method of creating, storing and processing the data in only 0 and 1. The data transmitted or stored by digital technology is expressed in a string of 0 and 1. For example, the on and off signals can be expressed in 0 and 1 digital values, and the BCD or binary values are also digital values.

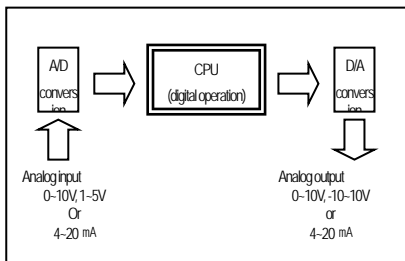

[Fig. 1.4] Process at PLC

Analog values cannot be directly input in the PLC CPU for an operation. That is why the analog values are converted in digital values when they are input in the PLC CPU as shown in Fig. 1.4. This is carried out by the Analog input module. In addition, for the analog values to be output to the outside, the PLC CPU digital values should be converted into analog values. This function is conducted by the D/A conversion module.

### 1.2.3. The Characteristics of Analog-Digital Conversion

#### (1) Voltage input

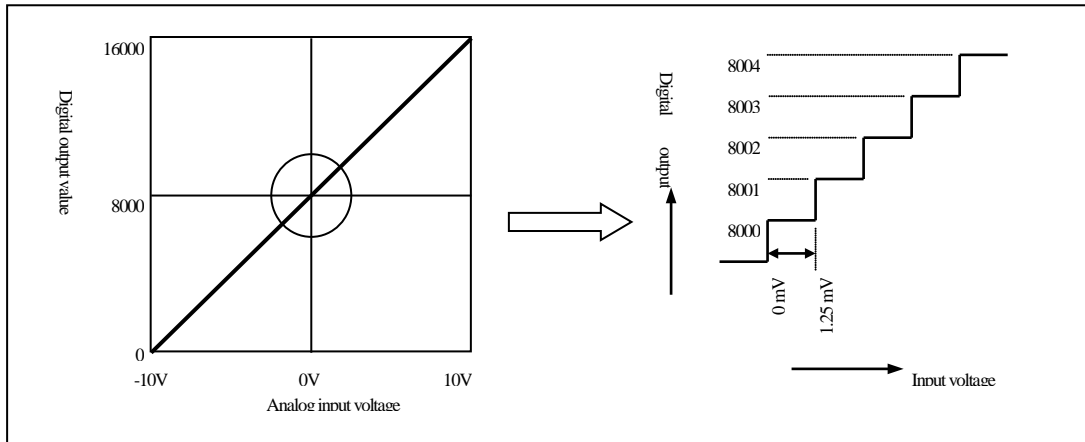

[Fig.1.5] A/D conversion characteristics (voltage input)

The Analog input module converts the analog electric signals that are input from an external device into digital values, which makes operations possible in the PLC CPU. When -10 ~ 10 V is used as the analog input range in the Analog input module, the analog input quantity of -10V is digital value 0, and that of 10V is digital value 16000. Therefore this case analog input 1.25mv corresponds to digital value 1 (Fig. 1.5).

#### (2) Current input

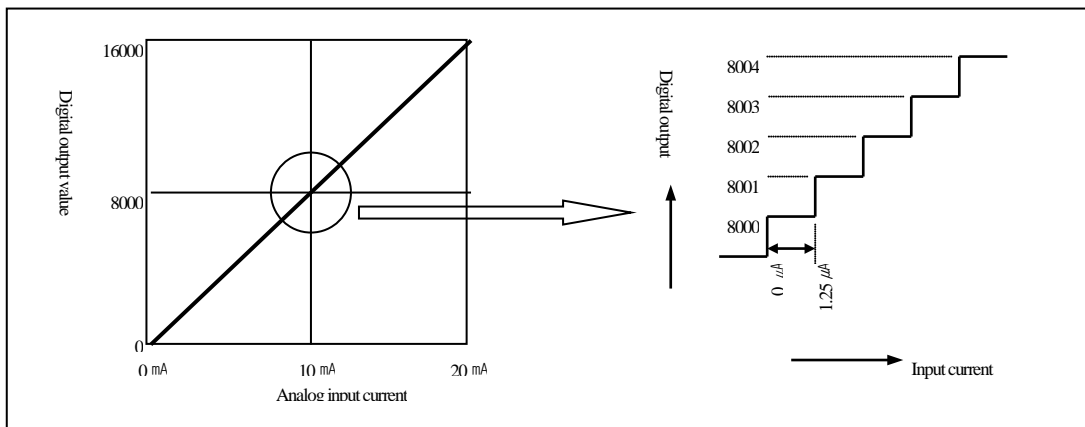

[Fig.1.6] A/D conversion characteristics (current input)

If 0-20mA is used as the analog input range in an Analog input module, the analog input value of 0mA is output as digital value 0, and the analog input value of 20mA is digital 16000. In this case, analog input 1.25  $\mu$ A corresponds to digital value 1 (Fig. 1.6).

### 1.3. New Functions

The new functions of Analog input module are as follows.

| Item            | Description  | Module OS version | CPU OS version                   | Ref. |
|-----------------|--|-------------------|----------------------------------|------|
| Hold last value | When input signal exceeds effective range, holds last effective input value. | V1.02             | Not related                      | 2.5  |
| Alarm function  | When input signal exceeds effective range, relevant alarm flag turns on.     | V1.02             | XGK V3.2<br>XGI V3.1<br>XGR V1.7 | 2.5  |

## Chapter 2 Specification

### 2.1 General Specifications

Table 2.1 shows the general specifications of XGT series.

[Table 2.1] General specifications

| No.         | Item                       | Specification  | Related specifications              |                            |  |                                   |
|-------------|----------------------------|--|-------------------------------------|----------------------------|--|-----------------------------------|
| 1           | Operating temperature      | 0°C ~ +55°C  | -                                   |                            |  |                                   |
| 2           | Storage temperature        | -25°C ~ +70°C  | -                                   |                            |  |                                   |
| 3           | Operating humidity         | 5 ~ 95%RH, Non-condensing  | -                                   |                            |  |                                   |
| 4           | Storage humidity           | 5 ~ 95%RH, Non-condensing  | -                                   |                            |  |                                   |
| 5           | Vibration                  | For discontinuous vibration  |                                     | IEC61131-2                 |  |                                   |
|             |                            | Frequency  | Acceleration                        |                            | Amplitude  | Number                            |
|             |                            | 5≤f< 8.4Hz   | -                                   |                            | 3,5mm  |                                   |
|             |                            | 8.4≤f≤150Hz  | 9.8m/s <sup>2</sup> (1G)            |                            | -  | Each 10 times in X,Y,Z directions |
|             |                            | For continuous vibration   |                                     |                            |  |                                   |
|             |                            | Frequency  | Acceleration                        |                            | Amplitude  |                                   |
|             |                            | 5≤f< 8.4Hz   | -                                   |                            | 1.75mm   |                                   |
| 8.4≤f≤150Hz | 4.9m/s <sup>2</sup> (0.5G) | -  |                                     |                            |  |                                   |
| 6           | Shocks                     | * Maximum impact acceleration:147m/s <sup>2</sup> (15G)<br>* Authorized time :11ms<br>* Pulse wave : Signal half-wave pulse (Each 3 times in X,Y,Z directions) | IEC61131-2                          |                            |  |                                   |
| 7           | Impulse Noise              | Square wave impulse noise  | AC: ±1,500V<br>DC: ±900V            | LS ELECTRIC Standard       |  |                                   |
|             |                            | Electrostatic discharging  | Voltage : 4kV (contact discharging) | IEC 61131-2, IEC 61000-4-2 |  |                                   |
|             |                            | Radiated electromagnetic field noise   | 80 ~ 1000MHz, 10 V/m                | IEC 61131-2, IEC 61000-4-3 |  |                                   |
|             |                            | Fast Transient / burst noise   | Class<br>Voltage                    | Power module<br>2kV        | Digital/<br>Analog I/O<br>communication interface<br>1kV | IEC 61131-2,<br>IEC 61000-4-4     |
| 8           | Ambient conditions         | No corrosive gas or dust   | -                                   |                            |  |                                   |
| 9           | Operating height           | 2,000m or less   | -                                   |                            |  |                                   |
| 10          | Pollution degree           | 2 or less  | -                                   |                            |  |                                   |
| 11          | Cooling type               | Natural air cooling  | -                                   |                            |  |                                   |

#### Note

- (1) IEC (International Electrotechnical Commission): An international private group that aims at promoting international cooperation for standardization in electrical and electronic technology areas, publishes international standards and operates related conformity assessment systems.
- (2) Contamination: an indicator that shows the contamination level of the environment that determines the insulation of a device. Contamination level 2 is when there is only non-conductive contamination, and there is short conductivity when there is condensation.

## 2.2 Performance Specifications

Table 2.2 shows the performance specifications of an analog input module.

[Table 2.2] Performance specifications

|                                     | Specifications  |   |                               |                |          |          |            |                |           |            |          |   |                    |                      |           |             |           |               |             |          |           |                |                  |           |  |  |  |                               |           |           |                |           |  |              |              |  |               |              |           |                  |           |  |
|-------------------------------------|---|---|-------------------------------|----------------|----------|----------|------------|----------------|-----------|------------|----------|---|--------------------|----------------------|-----------|-------------|-----------|---------------|-------------|----------|-----------|----------------|------------------|-----------|--|--|--|-------------------------------|-----------|-----------|----------------|-----------|--|--------------|--------------|--|---------------|--------------|-----------|------------------|-----------|--|
|                                     | Voltage   | Current   |                               |                |          |          |            |                |           |            |          |   |                    |                      |           |             |           |               |             |          |           |                |                  |           |  |  |  |                               |           |           |                |           |  |              |              |  |               |              |           |                  |           |  |
| Analog input range                  | DC 1 ~ 5 V<br>DC 0 ~ 5 V<br>DC 0 ~ 10 V<br>DC -10 ~ 10 V<br>(input resistance: 1 M $\Omega$ min.)   | DC 4 ~ 20 mA<br>DC 0 ~ 20 mA<br>(input resistance: 250 $\Omega$ ) |                               |                |          |          |            |                |           |            |          |   |                    |                      |           |             |           |               |             |          |           |                |                  |           |  |  |  |                               |           |           |                |           |  |              |              |  |               |              |           |                  |           |  |
| Selection of the analog input range | <ul style="list-style-type: none"> <li>▶ Current and voltage are set with the DIP switch.</li> <li>▶ The analog input range is set in the XG5000 user (sequence) program or [i/O parameter].</li> <li>▶ Each input range can be set for each channel.</li> </ul>  |   |                               |                |          |          |            |                |           |            |          |   |                    |                      |           |             |           |               |             |          |           |                |                  |           |  |  |  |                               |           |           |                |           |  |              |              |  |               |              |           |                  |           |  |
| Digital output                      | <p>(1) Voltage</p> <table border="1" style="width: 100%; border-collapse: collapse; text-align: center;"> <thead> <tr> <th style="text-align: left;">Analog input \ Digital output</th> <th>1 ~ 5 V</th> <th>0 ~ 5 V</th> <th>0 ~ 10 V</th> <th>-10 ~ 10 V</th> </tr> </thead> <tbody> <tr> <td>Unsigned value</td> <td colspan="4">0 ~ 16000</td> </tr> <tr> <td>Signed value</td> <td colspan="4">-8000 ~ 8000</td> </tr> <tr> <td>Precise value</td> <td>1000 ~ 5000</td> <td>0 ~ 5000</td> <td>0 ~ 10000</td> <td>-10000 ~ 10000</td> </tr> <tr> <td>Percentile value</td> <td colspan="4">0 ~ 10000</td> </tr> </tbody> </table> <p>(2) Current</p> <table border="1" style="width: 100%; border-collapse: collapse; text-align: center;"> <thead> <tr> <th style="text-align: left;">Analog input \ Digital output</th> <th>4 ~ 20 mA</th> <th>0 ~ 20 mA</th> </tr> </thead> <tbody> <tr> <td>Unsigned value</td> <td colspan="2">0 ~ 16000</td> </tr> <tr> <td>Signed value</td> <td colspan="2">-8000 ~ 8000</td> </tr> <tr> <td>Precise value</td> <td>4000 ~ 20000</td> <td>0 ~ 20000</td> </tr> <tr> <td>Percentile value</td> <td colspan="2">0 ~ 10000</td> </tr> </tbody> </table> <ul style="list-style-type: none"> <li>▶ 14 bit binary value</li> <li>▶ The digital output data format can be set through the user program or the [i/O parameter] of XG5000 for each channel.</li> </ul> |   | Analog input \ Digital output | 1 ~ 5 V        | 0 ~ 5 V  | 0 ~ 10 V | -10 ~ 10 V | Unsigned value | 0 ~ 16000 |            |          |   | Signed value       | -8000 ~ 8000         |           |             |           | Precise value | 1000 ~ 5000 | 0 ~ 5000 | 0 ~ 10000 | -10000 ~ 10000 | Percentile value | 0 ~ 10000 |  |  |  | Analog input \ Digital output | 4 ~ 20 mA | 0 ~ 20 mA | Unsigned value | 0 ~ 16000 |  | Signed value | -8000 ~ 8000 |  | Precise value | 4000 ~ 20000 | 0 ~ 20000 | Percentile value | 0 ~ 10000 |  |
| Analog input \ Digital output       | 1 ~ 5 V   | 0 ~ 5 V   | 0 ~ 10 V                      | -10 ~ 10 V     |          |          |            |                |           |            |          |   |                    |                      |           |             |           |               |             |          |           |                |                  |           |  |  |  |                               |           |           |                |           |  |              |              |  |               |              |           |                  |           |  |
| Unsigned value                      | 0 ~ 16000   |   |                               |                |          |          |            |                |           |            |          |   |                    |                      |           |             |           |               |             |          |           |                |                  |           |  |  |  |                               |           |           |                |           |  |              |              |  |               |              |           |                  |           |  |
| Signed value                        | -8000 ~ 8000  |   |                               |                |          |          |            |                |           |            |          |   |                    |                      |           |             |           |               |             |          |           |                |                  |           |  |  |  |                               |           |           |                |           |  |              |              |  |               |              |           |                  |           |  |
| Precise value                       | 1000 ~ 5000   | 0 ~ 5000  | 0 ~ 10000                     | -10000 ~ 10000 |          |          |            |                |           |            |          |   |                    |                      |           |             |           |               |             |          |           |                |                  |           |  |  |  |                               |           |           |                |           |  |              |              |  |               |              |           |                  |           |  |
| Percentile value                    | 0 ~ 10000   |   |                               |                |          |          |            |                |           |            |          |   |                    |                      |           |             |           |               |             |          |           |                |                  |           |  |  |  |                               |           |           |                |           |  |              |              |  |               |              |           |                  |           |  |
| Analog input \ Digital output       | 4 ~ 20 mA   | 0 ~ 20 mA   |                               |                |          |          |            |                |           |            |          |   |                    |                      |           |             |           |               |             |          |           |                |                  |           |  |  |  |                               |           |           |                |           |  |              |              |  |               |              |           |                  |           |  |
| Unsigned value                      | 0 ~ 16000   |   |                               |                |          |          |            |                |           |            |          |   |                    |                      |           |             |           |               |             |          |           |                |                  |           |  |  |  |                               |           |           |                |           |  |              |              |  |               |              |           |                  |           |  |
| Signed value                        | -8000 ~ 8000  |   |                               |                |          |          |            |                |           |            |          |   |                    |                      |           |             |           |               |             |          |           |                |                  |           |  |  |  |                               |           |           |                |           |  |              |              |  |               |              |           |                  |           |  |
| Precise value                       | 4000 ~ 20000  | 0 ~ 20000   |                               |                |          |          |            |                |           |            |          |   |                    |                      |           |             |           |               |             |          |           |                |                  |           |  |  |  |                               |           |           |                |           |  |              |              |  |               |              |           |                  |           |  |
| Percentile value                    | 0 ~ 10000   |   |                               |                |          |          |            |                |           |            |          |   |                    |                      |           |             |           |               |             |          |           |                |                  |           |  |  |  |                               |           |           |                |           |  |              |              |  |               |              |           |                  |           |  |
| Maximum resolution                  | <table border="1" style="width: 100%; border-collapse: collapse; text-align: center;"> <thead> <tr> <th>Analog input range</th> <th>Resolution (1/16000)</th> </tr> </thead> <tbody> <tr> <td>1 ~ 5 V</td> <td>0.250 mV</td> </tr> <tr> <td>0 ~ 5 V</td> <td>0.3125 mV</td> </tr> <tr> <td>0 ~ 10 V</td> <td>0.625 mV</td> </tr> <tr> <td>-10 ~ 10 V</td> <td>1.250 mV</td> </tr> </tbody> </table>   | Analog input range  | Resolution (1/16000)          | 1 ~ 5 V        | 0.250 mV | 0 ~ 5 V  | 0.3125 mV  | 0 ~ 10 V       | 0.625 mV  | -10 ~ 10 V | 1.250 mV | <table border="1" style="width: 100%; border-collapse: collapse; text-align: center;"> <thead> <tr> <th>Analog input range</th> <th>Resolution (1/16000)</th> </tr> </thead> <tbody> <tr> <td>4 ~ 20 mA</td> <td>1.0 <math>\mu</math>A</td> </tr> <tr> <td>0 ~ 20 mA</td> <td>1.25 <math>\mu</math>A</td> </tr> </tbody> </table> | Analog input range | Resolution (1/16000) | 4 ~ 20 mA | 1.0 $\mu$ A | 0 ~ 20 mA | 1.25 $\mu$ A  |             |          |           |                |                  |           |  |  |  |                               |           |           |                |           |  |              |              |  |               |              |           |                  |           |  |
| Analog input range                  | Resolution (1/16000)  |   |                               |                |          |          |            |                |           |            |          |   |                    |                      |           |             |           |               |             |          |           |                |                  |           |  |  |  |                               |           |           |                |           |  |              |              |  |               |              |           |                  |           |  |
| 1 ~ 5 V                             | 0.250 mV  |   |                               |                |          |          |            |                |           |            |          |   |                    |                      |           |             |           |               |             |          |           |                |                  |           |  |  |  |                               |           |           |                |           |  |              |              |  |               |              |           |                  |           |  |
| 0 ~ 5 V                             | 0.3125 mV   |   |                               |                |          |          |            |                |           |            |          |   |                    |                      |           |             |           |               |             |          |           |                |                  |           |  |  |  |                               |           |           |                |           |  |              |              |  |               |              |           |                  |           |  |
| 0 ~ 10 V                            | 0.625 mV  |   |                               |                |          |          |            |                |           |            |          |   |                    |                      |           |             |           |               |             |          |           |                |                  |           |  |  |  |                               |           |           |                |           |  |              |              |  |               |              |           |                  |           |  |
| -10 ~ 10 V                          | 1.250 mV  |   |                               |                |          |          |            |                |           |            |          |   |                    |                      |           |             |           |               |             |          |           |                |                  |           |  |  |  |                               |           |           |                |           |  |              |              |  |               |              |           |                  |           |  |
| Analog input range                  | Resolution (1/16000)  |   |                               |                |          |          |            |                |           |            |          |   |                    |                      |           |             |           |               |             |          |           |                |                  |           |  |  |  |                               |           |           |                |           |  |              |              |  |               |              |           |                  |           |  |
| 4 ~ 20 mA                           | 1.0 $\mu$ A   |   |                               |                |          |          |            |                |           |            |          |   |                    |                      |           |             |           |               |             |          |           |                |                  |           |  |  |  |                               |           |           |                |           |  |              |              |  |               |              |           |                  |           |  |
| 0 ~ 20 mA                           | 1.25 $\mu$ A  |   |                               |                |          |          |            |                |           |            |          |   |                    |                      |           |             |           |               |             |          |           |                |                  |           |  |  |  |                               |           |           |                |           |  |              |              |  |               |              |           |                  |           |  |
| Precision                           | Below $\pm 0.2\%$ (when the surrounding temperature is 25 $^{\circ}$ C $\pm 5$ $^{\circ}$ C)<br>Below $\pm 0.3\%$ (when the surrounding temperature is 0 $^{\circ}$ C ~ 55 $^{\circ}$ C)  |   |                               |                |          |          |            |                |           |            |          |   |                    |                      |           |             |           |               |             |          |           |                |                  |           |  |  |  |                               |           |           |                |           |  |              |              |  |               |              |           |                  |           |  |
| Maximum conversion speed            | 250 $\mu$ s/channel   |   |                               |                |          |          |            |                |           |            |          |   |                    |                      |           |             |           |               |             |          |           |                |                  |           |  |  |  |                               |           |           |                |           |  |              |              |  |               |              |           |                  |           |  |
| Absolute maximum input              | $\pm 15$ V  | $\pm 30$ mA   |                               |                |          |          |            |                |           |            |          |   |                    |                      |           |             |           |               |             |          |           |                |                  |           |  |  |  |                               |           |           |                |           |  |              |              |  |               |              |           |                  |           |  |
| Analog input                        | 8 channel/module  |   |                               |                |          |          |            |                |           |            |          |   |                    |                      |           |             |           |               |             |          |           |                |                  |           |  |  |  |                               |           |           |                |           |  |              |              |  |               |              |           |                  |           |  |
| Insulation                          | Photo coupler insulation between the input terminal and PLC power source (no insulation between channels)   |   |                               |                |          |          |            |                |           |            |          |   |                    |                      |           |             |           |               |             |          |           |                |                  |           |  |  |  |                               |           |           |                |           |  |              |              |  |               |              |           |                  |           |  |
| Access terminal                     | 18 point terminal block   |   |                               |                |          |          |            |                |           |            |          |   |                    |                      |           |             |           |               |             |          |           |                |                  |           |  |  |  |                               |           |           |                |           |  |              |              |  |               |              |           |                  |           |  |
| Input and output occupancy point    | Fixed type: 64, adjustable type: 16 points  |   |                               |                |          |          |            |                |           |            |          |   |                    |                      |           |             |           |               |             |          |           |                |                  |           |  |  |  |                               |           |           |                |           |  |              |              |  |               |              |           |                  |           |  |
| Internal current consumption        | 420 mA  |   |                               |                |          |          |            |                |           |            |          |   |                    |                      |           |             |           |               |             |          |           |                |                  |           |  |  |  |                               |           |           |                |           |  |              |              |  |               |              |           |                  |           |  |
| Weight                              | 140g  |   |                               |                |          |          |            |                |           |            |          |   |                    |                      |           |             |           |               |             |          |           |                |                  |           |  |  |  |                               |           |           |                |           |  |              |              |  |               |              |           |                  |           |  |

### Note

- (1) The analog input module has the offset and gain values set for each analog input range when it is manufactured. The user cannot change the values.
- (2) The voltage/current selection switch is set at current when shipped at the factory.
- (3) Offset value: the analog input value of which the digital output value is 0 when the digital output type is set as an unsigned value
- (4) Gain value: the analog input value of which the digital output value is 16000 when the digital output type is set as an unsigned value
- (5) The XGR system can be used at the extended base, not the basic base.

## 2.3 Description of the Parts

This section is about the name of each part.

### 2.3.1 The Analog Input Module

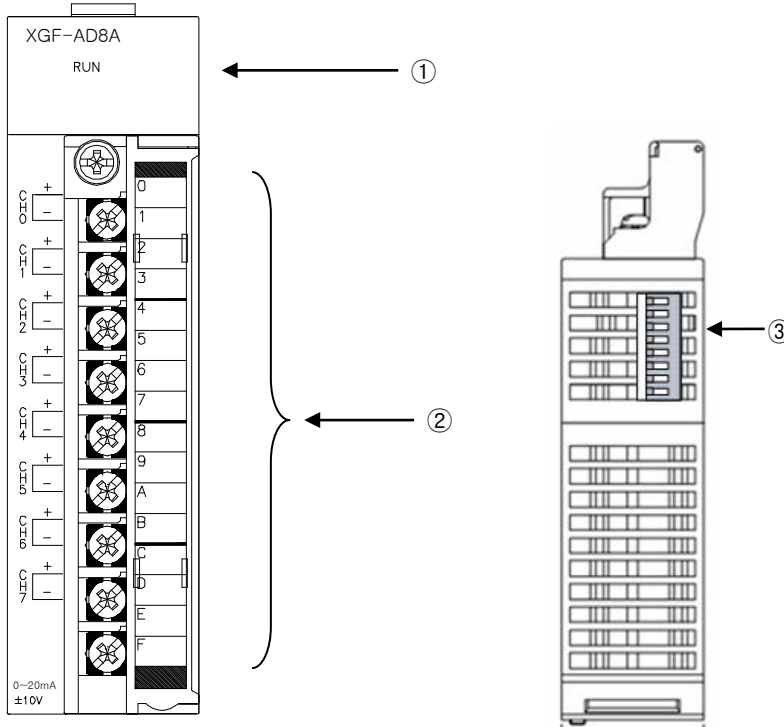

| No.    | Name                           | Description   |        |         |     |         |    |         |
|--------|--------------------------------|---|--------|---------|-----|---------|----|---------|
| ①      | Operation display LED          | <ul style="list-style-type: none"> <li>▶ Displays the operating status of XGF-AD8A</li> <li>On: operating normally</li> <li>Flashing: Error. Disconnection detected</li> <li>Off: DC 5V disconnection, XGF-AD8A module failure</li> </ul>   |        |         |     |         |    |         |
| ②      | Terminal block                 | <ul style="list-style-type: none"> <li>▶ The terminal block connected to an external device for each channel for analog value current/voltage to be input</li> </ul>  |        |         |     |         |    |         |
| ③      | Current/voltage setting switch | <ul style="list-style-type: none"> <li>▶ the switch for setting the input time (current/voltage)</li> </ul> <div style="display: flex; align-items: center; justify-content: center;"> <table border="1" style="margin-left: 20px;"> <thead> <tr> <th>Switch</th> <th>Setting</th> </tr> </thead> <tbody> <tr> <td>Off</td> <td>Voltage</td> </tr> <tr> <td>On</td> <td>Current</td> </tr> </tbody> </table> </div> | Switch | Setting | Off | Voltage | On | Current |
| Switch | Setting                        |   |        |         |     |         |    |         |
| Off    | Voltage                        |   |        |         |     |         |    |         |
| On     | Current                        |   |        |         |     |         |    |         |

## 2.4 Characteristics of Input/Output Conversion

The characteristics of input/output conversion is the slope of the straight line connecting the offset and the gain values when the analog signals (current or voltage input) from the PLC external device into digital values.

Below are the characteristics of input/output conversion of the analog input module.

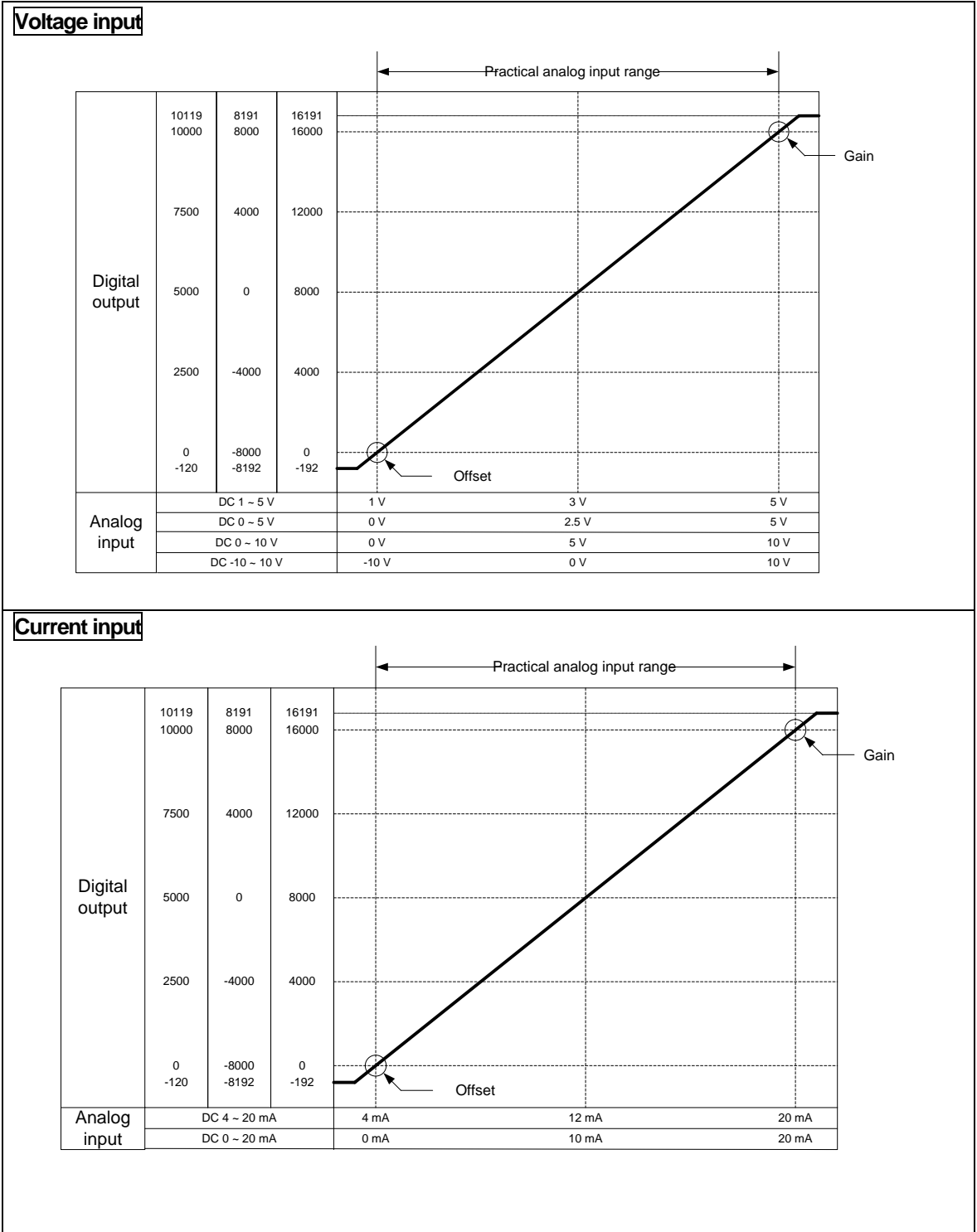

### 2.4.1 Input/Output Characteristics of XGF-AD8A

Being a 8 channel analog input module, the offset/gain of the analog input module cannot be set by the user. The voltage input range can be set for each channel by using the user program or [I/O parameter] of XG5000. The output form of the digital data is defined as follows.

- (a) Unsigned Value
- (b) Signed Value
- (c) Precise Value
- (d) Percentile Value

(1) In the range of DC 4 ~ 20 mA

- (a) Set [setting range] at 4 ~ 20 mA in [set I/O parameter] of XG5000.

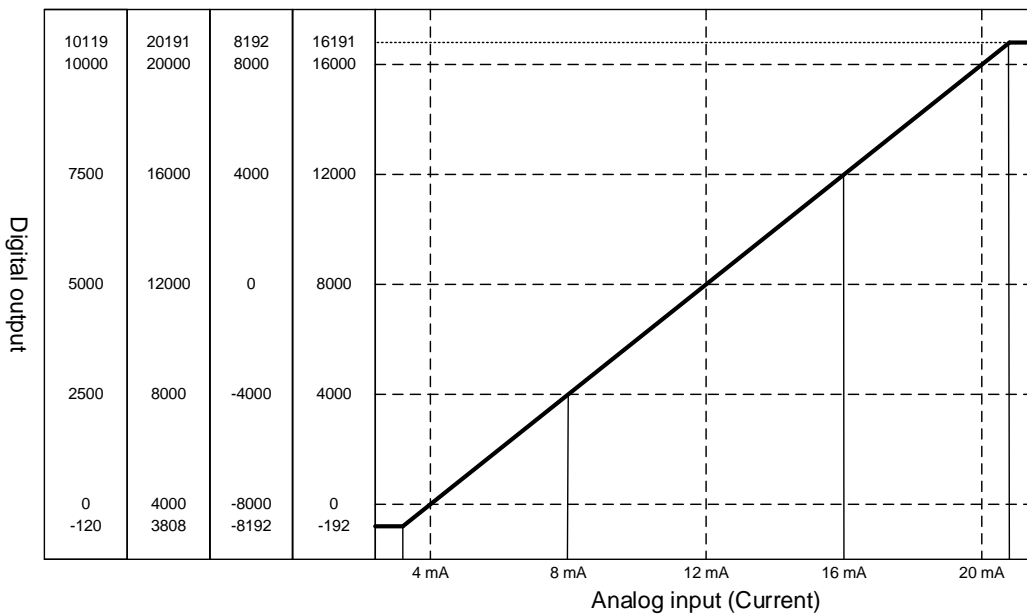
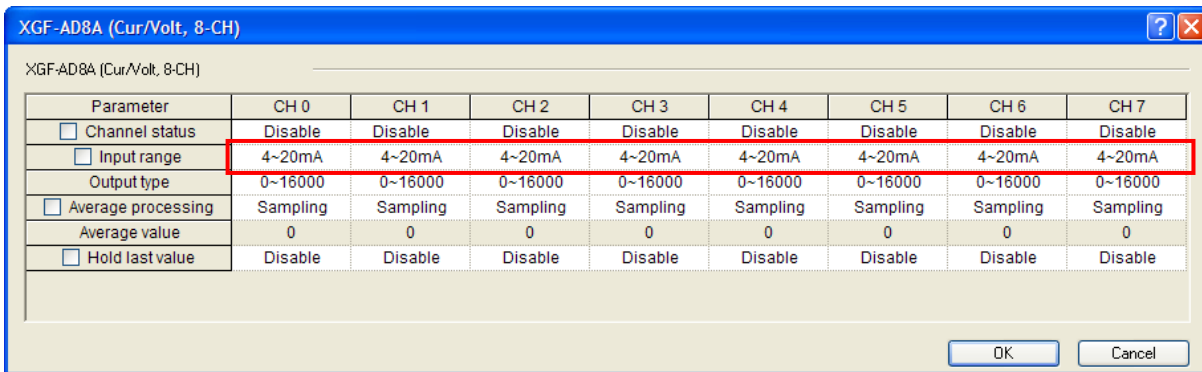

(b) The digital output values for the current input characteristics are as follows.

(Resolution (for 1/16000): 1  $\mu$ A)

| Digital output range               | Analog input current (mA) |       |       |       |       |       |        |
|------------------------------------|---------------------------|-------|-------|-------|-------|-------|--------|
|                                    | 3.808                     | 4     | 8     | 12    | 16    | 20    | 20.191 |
| Unsigned value<br>(-192 ~ 16191)   | -192                      | 0     | 4000  | 8000  | 12000 | 16000 | 16191  |
| Signed value<br>(-8192 ~ 8191)     | -8192                     | -8000 | -4000 | 0     | 4000  | 8000  | 8191   |
| Precise value<br>(3808 ~ 20191)    | 3808                      | 4000  | 8000  | 12000 | 16000 | 20000 | 20191  |
| Percentile value<br>(-120 ~ 10119) | -120                      | 0     | 2500  | 5000  | 7500  | 10000 | 10119  |

(2) In the range of DC 0 ~ 20 mA

(a) Set [setting range] at 0 ~ 20 mA in [set I/O parameter] of XG5000.

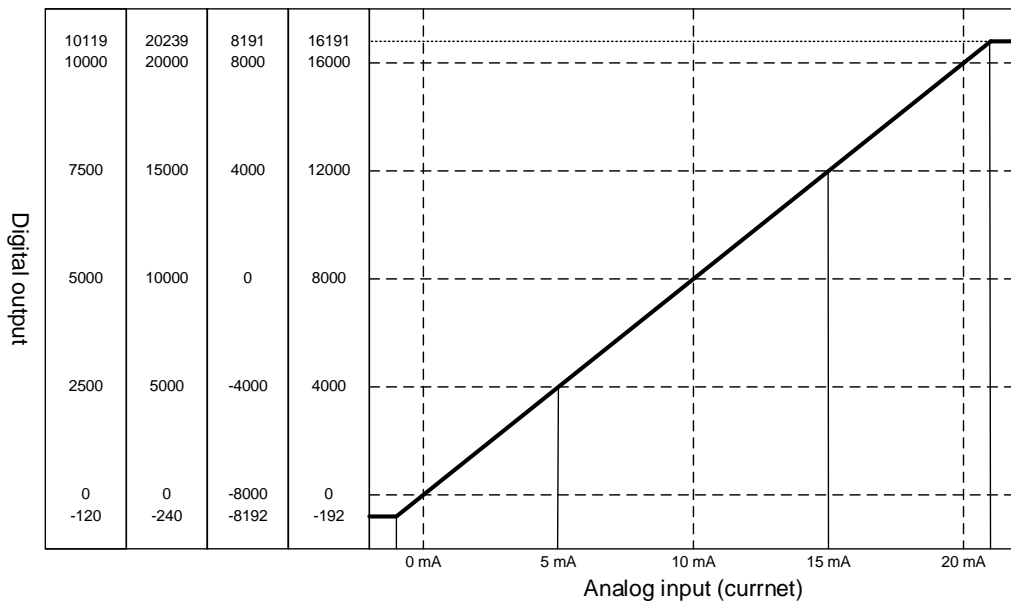
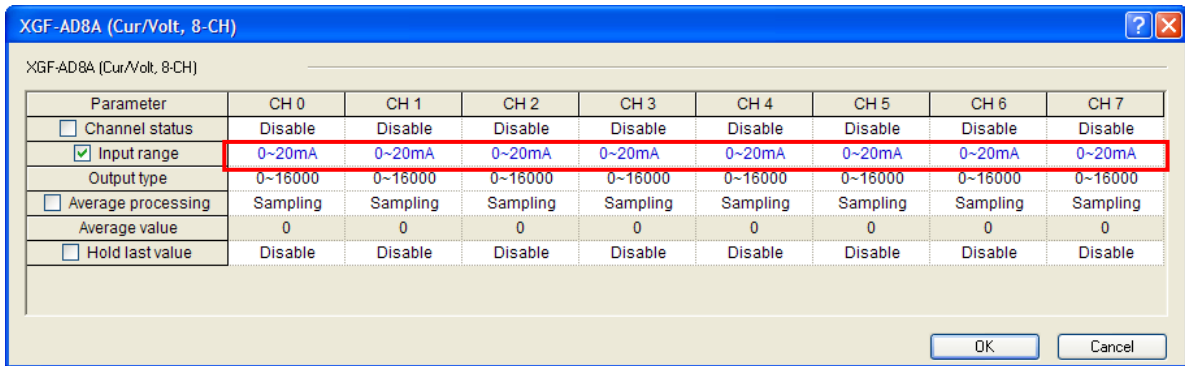

(b) The digital output values for the current input characteristics are as follows.

(resolution (for 1/16000): 1.25  $\mu$ A)

| Digital output range               | Analog input current (mA) |       |       |       |       |       |        |
|------------------------------------|---------------------------|-------|-------|-------|-------|-------|--------|
|                                    | -0.24                     | 0     | 5     | 10    | 15    | 20    | 20.239 |
| Unsigned value<br>(-192 ~ 16191)   | -192                      | 0     | 4000  | 8000  | 12000 | 16000 | 16191  |
| Signed value<br>(-8192 ~ 8191)     | -8192                     | -8000 | -4000 | 0     | 4000  | 8000  | 8191   |
| Precise value<br>(-240 ~ 20239)    | -240                      | 0     | 5000  | 10000 | 15000 | 20000 | 20239  |
| Percentile value<br>(-120 ~ 10119) | -120                      | 0     | 2500  | 5000  | 7500  | 10000 | 10119  |

(3) In the range of DC 1 ~ 5 V

(a) Set [setting range] at 1-5V in [set I/O parameter] of XG5000.

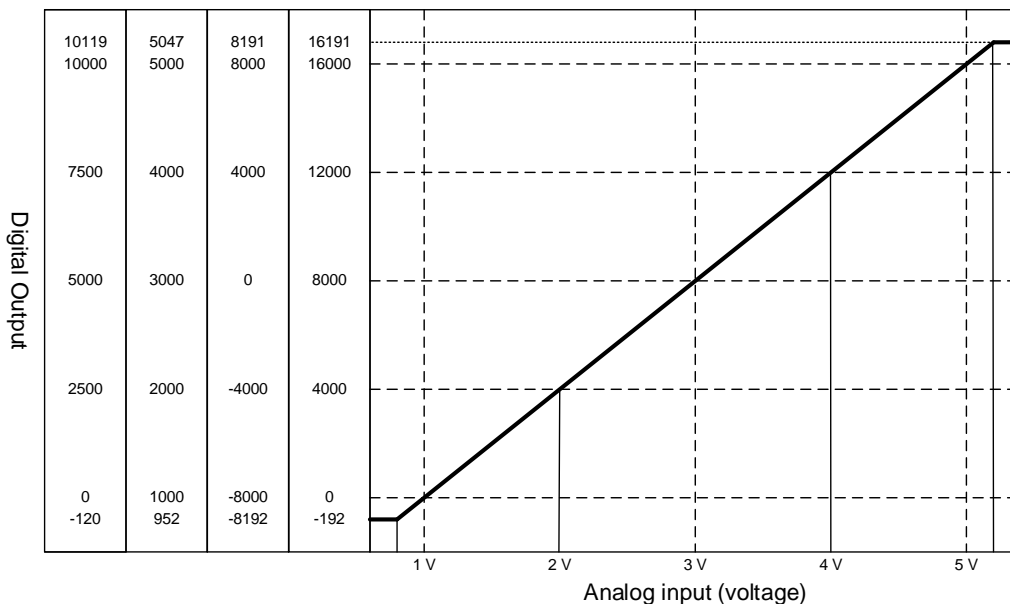
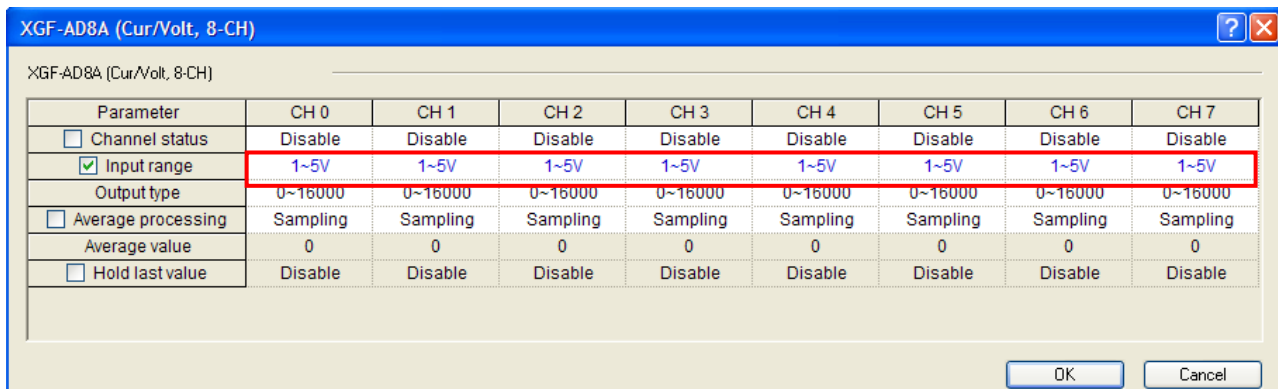

(b) The digital output values for the voltage input characteristics are as follows.

(resolution (for 1/16000): 0.25 mV)

| Digital output range               | Analog input voltage (V) |       |       |      |       |       |       |
|------------------------------------|--------------------------|-------|-------|------|-------|-------|-------|
|                                    | 0.952                    | 1     | 2     | 3    | 4     | 5     | 5.047 |
| Unsigned value<br>(-192 ~ 16191)   | -192                     | 0     | 4000  | 8000 | 12000 | 16000 | 16191 |
| Signed value<br>(-8192 ~ 8191)     | -8192                    | -8000 | -4000 | 0    | 4000  | 8000  | 8191  |
| Precise value<br>(952 ~ 5047)      | 952                      | 1000  | 2000  | 3000 | 4000  | 5000  | 5047  |
| Percentile value<br>(-120 ~ 10119) | -120                     | 0     | 2500  | 5000 | 7500  | 10000 | 10119 |

(4) In the range of DC 0 ~ 5 V

(a) Set [setting range] at 0 ~ 5V in [set I/O parameter] of XG5000

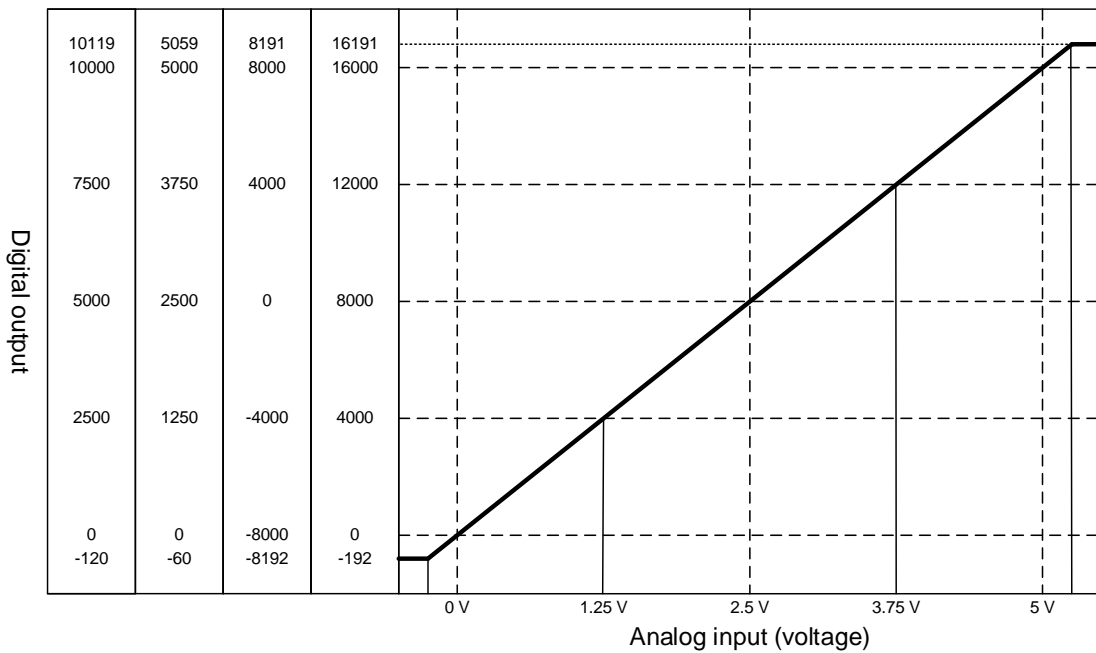
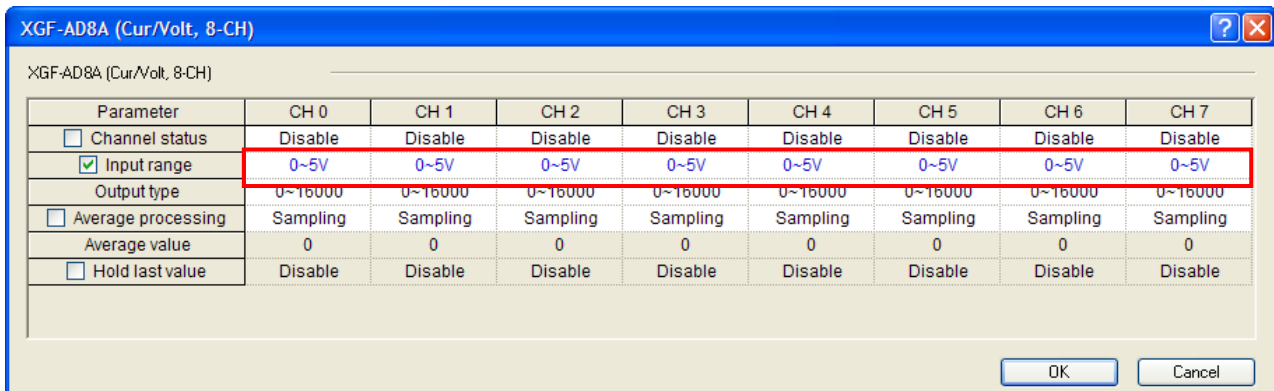

(b) The digital output values for the voltage input characteristics are as follows.  
 (resolution (for 1/16000): 0.3125 mV)

| Digital output range               | Analog input voltage (V) |       |       |      |       |       |       |
|------------------------------------|--------------------------|-------|-------|------|-------|-------|-------|
|                                    | -0.06                    | 0     | 1.25  | 2.5  | 3.75  | 5     | 5.05  |
| Unsigned value<br>(-192 ~ 16191)   | -192                     | 0     | 4000  | 8000 | 12000 | 16000 | 16191 |
| Signed value<br>(-8192 ~ 8191)     | -8192                    | -8000 | -4000 | 0    | 4000  | 8000  | 8191  |
| Precise value<br>(-60 ~ 5060)      | -60                      | 0     | 1250  | 2500 | 3750  | 5000  | 5059  |
| Percentile value<br>(-120 ~ 10119) | -120                     | 0     | 2500  | 5000 | 7500  | 10000 | 10119 |

(5) In the range of DC 0 ~ 10 V

(a) Set [setting range] at 0 ~ 10V in [set I/O parameter] of XG5000.

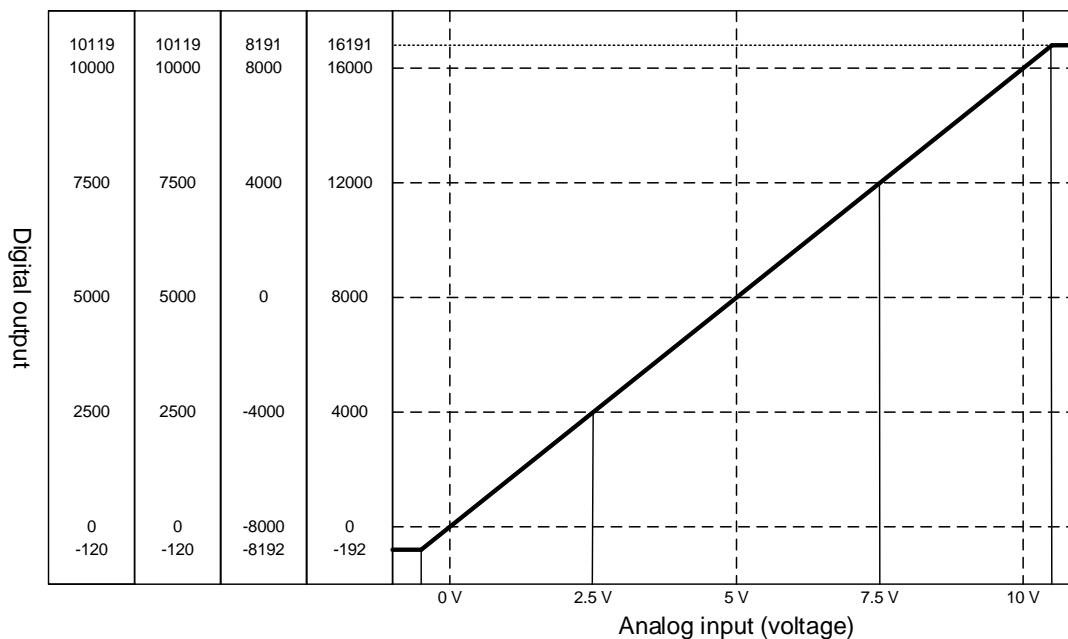
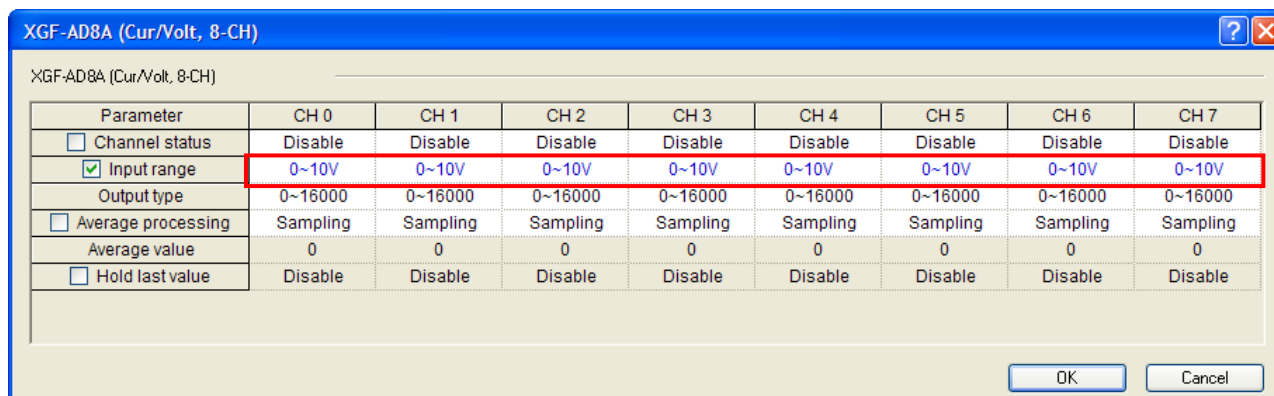

(b) The digital output values for the voltage input characteristics are as follows.

(resolution (for 1/16000): 0.625 mV)

| Digital output range               | Analog input voltage (V) |       |       |      |       |       |        |
|------------------------------------|--------------------------|-------|-------|------|-------|-------|--------|
|                                    | -0.12                    | 0     | 2.5   | 5    | 7.5   | 10    | 10.119 |
| Unsigned value<br>(-192 ~ 16191)   | -192                     | 0     | 4000  | 8000 | 12000 | 16000 | 16191  |
| Signed value<br>(-8192 ~ 8191)     | -8192                    | -8000 | -4000 | 0    | 4000  | 8000  | 8191   |
| Precise value<br>(-120 ~ 10119)    | -120                     | 0     | 2500  | 5000 | 7500  | 10000 | 10119  |
| Percentile value<br>(-120 ~ 10119) | -120                     | 0     | 2500  | 5000 | 7500  | 10000 | 10119  |

(6) In the range of DC-10 ~ 10 V

(a) Set [setting range] at -10 ~ 10V in [set I/O parameter] of XG5000.

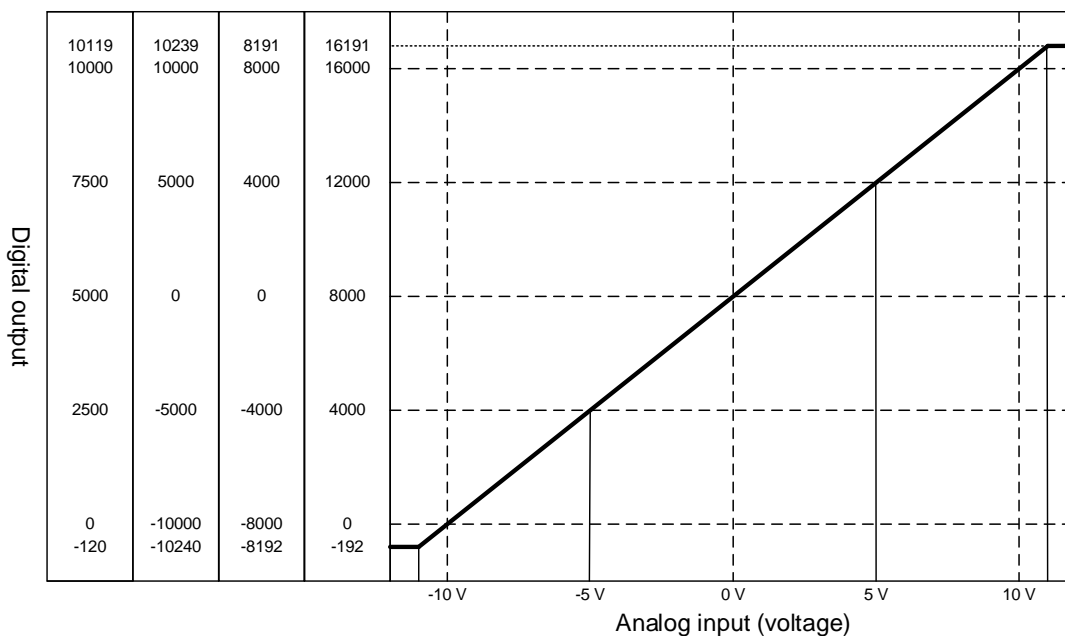
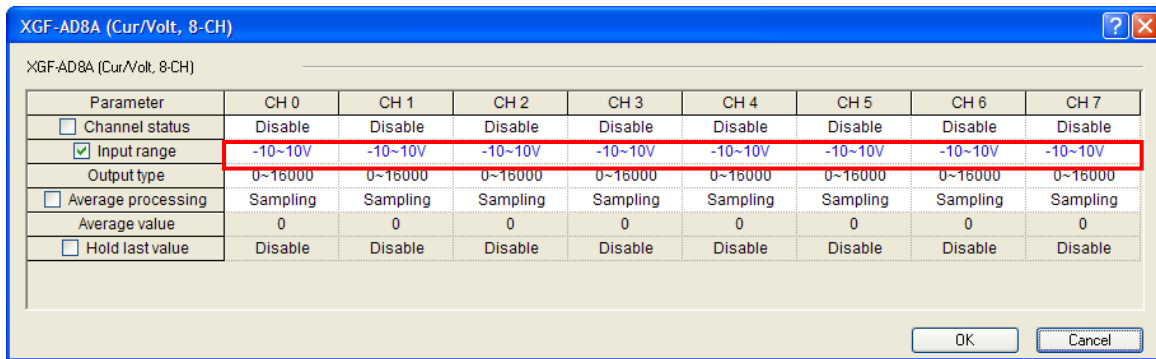

(b) The digital output values for the voltage input characteristics are as follows.

(resolution (for 1/16000): 1.25 mV)

| Digital output range               | Analog input voltage (V) |       |       |      |       |       |       |
|------------------------------------|--------------------------|-------|-------|------|-------|-------|-------|
|                                    | -10.24                   | -10   | -5    | 0    | 5     | 10    | 10.23 |
| Unsigned value<br>(-192 ~ 16191)   | -192                     | 0     | 4000  | 8000 | 12000 | 16000 | 16191 |
| Signed value<br>(-8192 ~ 8191)     | -8192                    | -8000 | -4000 | 0    | 4000  | 8000  | 8191  |
| Precise value<br>(-10240 ~ 10239)  | -10240                   | 0     | 2500  | 5000 | 7500  | 10000 | 10239 |
| Percentile value<br>(-120 ~ 10119) | -120                     | 0     | 2500  | 5000 | 7500  | 10000 | 10119 |

### Note

(1) When a value out of the digital output range is inputted as the analog input value, the digital output value is maintained as the maximum or the minimum value that fall within the set output range. For example, when the digital output range is set as the Unsigned value (-192 ~ 16191), and an analog value that exceed 6191 or -192 is entered as the digital output value, the digital output value is fixed at 16191 or -192.

(2) The offset/gain of the analog input module cannot be set by the user.



### Caution

▶ Do not put the voltage and current beyond  $\pm 15$  V and  $\pm 30$  mA respectively. Otherwise it may cause a failure due to over current/voltage.

### 2.4.2 Precision

The precision for the digital output value does not change if the input range is changed. Fig 2.1 shows the range of precision at surrounding temperatures of  $25 \pm 5^\circ\text{C}$  when the analog input range and digital output type are set at  $-10 \sim 10 \text{ V}$  and Unsigned value respectively. The precision is  $\pm 0.2\%$  and  $\pm 0.3\%$  when the temperature is  $25 \pm 5^\circ\text{C}$  and  $0 \sim 55^\circ\text{C}$  respectively.

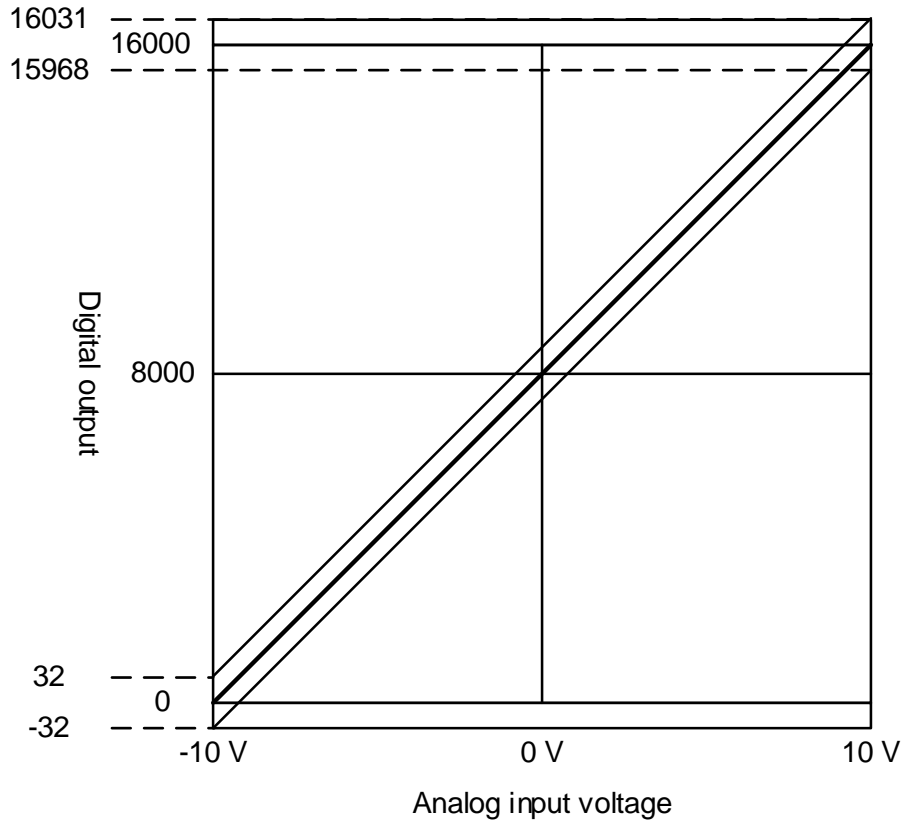

[Fig. 2.1] Precision (at  $25 \pm 5^\circ\text{C}$ )

## 2.5 Functions of the Analog Input Module

[Table 2.3] explains the functions of the analog conversion module.

[Table 2.3] List of functions

| Functions                           | Description  | Reference      |
|-------------------------------------|--|----------------|
| Set channel operating/stop          | Sets the operating/stop of the channel to conduct A/D conversion.<br>You can reduce the time it takes for analog conversion by setting the channel you don't use at stop.  |                |
| Set input voltage/current ranges    | Sets the analog input range you want to use.<br>There are 4 input ranges for voltage input, and 2 for current input.   |                |
| Set the output data type            | Sets the digital output type.<br>4 output data types are provided in this module.  |                |
| A/D conversion type                 | (1) Sampling<br>When no A/D conversion type is specified<br>(2) Average time/number<br>Outputs the A/D conversion value of the average frequency or time.<br>(3) Weighted average<br>Slows a sudden change of the input value. |                |
| Detection of an input disconnection | If the analog input at 4 ~ 20 mA and 1 ~ 5 V is disconnected, it can be detected in the user program.  |                |
| Hold last value                     | (1) This function is supported at current input (4~20mA, 0~20mA)<br>(2) When input signal exceeds the effective range, holds the last effective value.   | 2.5.4<br>5.3.7 |
| Alarm function                      | (1) Separate setting is not necessary<br>(2) When input signal exceeds the effective range, relevant flag turns on to let the user know  | 2.5.5<br>5.1.1 |

There are sampling and average processing types for A/D conversion.

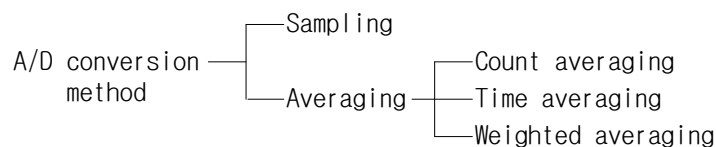

### 2.5.1 Sampling Processing

A common A/D conversion, sampling processing conducts A/D conversion collecting analog input signals at a regular interval. The time it takes for the analog input signals to be A/D converted and stored in the memory differs according to the number of the channels being used.

$$(\text{Processing time}) = (\text{number of channels being used}) \times (\text{conversion speed})$$

e.g.) The processing time when 3 channels are being used

$$3 \times 250 \mu\text{s} = 750 \mu\text{s}$$

Sampling means picking up continuous analog signals as sample values at regular intervals.

### 2.5.2 Filter Processing

Filter processing is for getting stable digital output values by filtering sudden changes of the noise or input values. The filter constant can be set for each channel by setting the user program or I/O parameter.

(1) Settable range: 1 ~ 99(%)

$$F[n] = (1 - \alpha) \times A[n] + \alpha \times F[n - 1]$$

$F[n]$ : the current filter output value  
 $A[n]$ : the current A/D conversion value  
 $F[n-1]$ : the previous filter output value  
 $\alpha$ : filter constant (0.01 ~ 0.99: filter value of the previous value)

- (a) If you do not set the time average within 1~99, RUN LED flashes every second. If you want to keep RUN LED on, reset the time average within 4 ~ 16000 and switch the operating mode of the CPU module from STOP to RUN. If you want to end the error through modification, you must use the clear request flag (UXY.11.0).
- (b) In case of an error of the number average value setting, the set value is saved as 1, which is the initial value.

(2) Voltage input

- a) The analog input range is set at DC -10 ~ 10 V and the digital output range is set at 0 ~ 16000.
- b) When the analog input value changes -10 V → 10 V (0 → 16000), the filter output value according to  $\alpha$  is as follows.

| $\alpha$ value | Filter output value |        |         |         | Note                             |
|----------------|---------------------|--------|---------|---------|----------------------------------|
|                | -                   | 1 scan | 2 scans | 3 scans |                                  |
| *1) 0.01       | 0                   | 15840  | 15998   | 15999   | 1% biased toward previous value  |
| *2) 0.5        | 0                   | 8000   | 12000   | 14000   | 50% biased toward previous value |
| *3) 0.99       | 0                   | 160    | 318     | 475     | 99% biased toward previous value |

- \*1) 16000 output after about 4 scans
- \*2) 16000 output after about 24 scans
- \*3) 16000 output after about 1491 scans (372.75 ms in case of 1 channel operation)

3) Current input

- a) The analog input range is set at DC 0 ~ 20 mA and the digital output range is set at 0 ~ 16000.
- b) When the analog input value changes 0 mA → 10 mA (0 → 8000), the filter output value according to  $\alpha$  is as follows

| ( value  | Filter output value |        |         |         | Note                             |
|----------|---------------------|--------|---------|---------|----------------------------------|
|          | -                   | 1 scan | 2 scans | 3 scans |                                  |
| *1) 0.01 | 0                   | 7920   | 7999    | 7999    | 1% biased toward previous value  |
| *2) 0.5  | 0                   | 4000   | 6000    | 7000    | 50% biased toward previous value |
| *3) 0.99 | 0                   | 80     | 159     | 237     | 99% biased toward previous value |

- \*1) 8000 output after about 4 scans

- \* 2) 16000 output after about 21 scans
- \*3) 8000 output after about 1422 scans (355.5 ms in case of 1 channel operation)

4) If you do not use the filter processing, the current A/D conversion value is directly output. Filter processing is getting data by putting a filter value between the current and the previous A/D conversion values, and the filter value can be decided by the average value. If there is much wavering of the output data, set the average value high.

### 2.5.3 Average Processing

The A/D conversion of a designated channel is conducted a set times or for a set time and the average of the sum is stored in the memory.

(1) Why is average processing used?

Abnormal analog input signals such as noise can be A/D converted to a value close to a normal analog input signal.

(2) Types of average processing

Average processing divides into time, count averages.

(c) Time average processing

1) Settable range: 16 ~ 16000 (ms)

2) The number of average processing processes within the set time is decided according to the number of the channels being used when you use the time average.

$$\text{Averaging Frequency} = \frac{\text{Set-up time}}{\text{No. channels used} \times \text{Conversion speed}}$$

Example 1) the number of channels being used: 1, set time: 16000 ms

$$\text{Averaging Frequency} = \frac{16000 \text{ ms}}{1 \times 0.25 \text{ ms}} = 64000 \text{ Times}$$

Example 2) the number of channels being used: 8, set time: 4 ms

$$\text{Averaging Frequency} = \frac{4 \text{ ms}}{8 \times 0.25 \text{ ms}} = 2 \text{ Times}$$

\*1: If you do not set the time average within 4 ~ 16000, RUN LED flashes every second. If you want to keep RUN LED on, reset the time average within 4 ~ 16000 and switch the operating mode of the CPU module from STOP to RUN. If you want to end the error through modification, you must use the clear request flag (UXY.11.0).

\*2: In case of an error of the time average value setting, the set value is saved as 4, which is the initial value.

The time average is converted into the number average inside the analog input module. In this case, there can be a remainder as time is divided by (the number of channels being used X conversion speed). The remainder is dropped, and the number of average processing processes is (the number of channels being used X conversion speed)/(set time).

Example) When the number of channels being used is 5 and the set time is 151 ms,

$$151 \text{ ms} \div (5 \times 0.25 \text{ ms}) = 120 \text{ times} \dots\dots \text{the remainder is } 8 \rightarrow 120 \text{ times}$$

(b) Count average processing

- 1) Settable range: 2 ~ 64000 (times)
- 2) When you use the number average, the times it takes for the average value to be saved in the memory differs according to the number of the channels being used.

The processing time = the set number X the number of the channels being used X conversion speed

\*1: If you do not set the time average within 2 ~ 64000, RUN LED flashes every second. If you want to keep RUN LED on, reset the time average within 2 ~ 64000 and switch the operating mode of the CPU module from STOP to RUN. If you want to end the error through modification, you must use the error clear request flag (UXY.11.0).

\*2: In case of an error of the number average value setting, the set value is saved as 2, which is the initial value.

Example) when the number of channels being used 4 and the number of average processing processes is 50 times,  
 $50 \times 4 \times (0.25 \text{ ms}) = 50 \text{ ms}$

### 2.5.3 Detection of Input Disconnection

(1) Settable range

You can detect disconnection of the input circuit when you use the input signal range of 4 ~ 20 mA, 1 ~ 5 V. The conditions for detection of each input signal range is as shown in the table below.

| Input signal range | Current/voltage values perceived as disconnection |
|--------------------|---|
| 1 ~ 5 V            | Below 0.2 V                                       |
| 4 ~ 20 mA          | Below 0.8 mA                                      |

(2) Display of disconnection by channel

The disconnection detection signal for each input channel is saved in UXY.10.

(X represents the base number and Y the slot number)

| Bit           | 15 | 14 | 13 | 12 | 11 | 10 | 9 | 8 | 7   | 6   | 5   | 4   | 3   | 2   | 1   | 0   |
|---------------|----|----|----|----|----|----|---|---|-----|-----|-----|-----|-----|-----|-----|-----|
| Initial value | 0  | 0  | 0  | 0  | 0  | 0  | 0 | 0 | 0   | 0   | 0   | 0   | 0   | 0   | 0   | 0   |
| Allocate      | -  | -  | -  | -  | -  | -  | - | - | CH7 | CH6 | CH5 | CH4 | CH3 | CH2 | CH1 | CH0 |

| BIT | Description  |
|-----|--------------|
| 0   | Normal       |
| 1   | Disconnected |

(3) Action

Each bit is set as 1 when a disconnection is detected of an allocated channel. Each bit can be used for detecting disconnection in the user program as shown in the table of conditions above.

(4) An example of the program

If a module is mounted in base 0, slot 2, below is an example of using the disconnection detection flag. If a disconnection is detected of the channel, the detected channel number is written in the P area.

(System configuration)

|          |          |  |  |          |  |
|----------|----------|--|--|----------|--|
| XGP-ACF2 | XGK-CPUH |  |  | XGF-AD8A |  |
|----------|----------|--|--|----------|--|



### 2.5.4 Hold last value (Dedicated for current input)

When input signal exceeds the effective range, last input value is held. This function can be set for each channel by I/O parameter setting or user program.

(1) Input range to be used

This function can be used when you use input signal range of 4~20mA, 0~20mA. So this function can be used in current input module. In this function - enabled channel, only value of effective range is indicated. For example, in case output data type is unsigned value, if this function is disabled, output data has the -192~16191 range. But this function is enabled, output data has the 0~16000 range.

| Input current range | Classification | Unsigned   | Signed     | Precise    | Percentile |
|---------------------|----------------|------------|------------|------------|------------|
| 4 ~ 20 mA           | Disable        | -192~16191 | -8192~8191 | 3808~20191 | -120~10119 |
|                     | Enable         | 0~16000    | -8000~8000 | 4000~20000 | 0~10000    |
| 0 ~ 20 mA           | Disable        | -192~16191 | -8192~8191 | -240~20239 | -120~10119 |
|                     | Enable         | 0~16000    | -8000~8000 | 0~20000    | 0~10000    |

(2) Operation

When this function is enabled and range is 4~20mA, output value corresponding to sample input value is as follows. (Output data type: 0~16000)

|                    |      |                 |   |       |                 |       |
|--------------------|------|-----------------|---|-------|-----------------|-------|
| Input current (mA) | 12   | 3               | 4 | 12    | 21              | 20    |
| Output value       | 8000 | 8000            | 0 | 12000 | 12000           | 16000 |
| Ref.               | -    | Hold last value | - | -     | Hold last value | -     |

### 2.5.5 Alarm function

When input signal exceeds effective range, relevant flag turns on.

(1) Input detection condition

Detection condition for each input signal range is as follows.

| Input signal range | Difference | Tolerance | Lower limit | Upper limit |
|--------------------|------------|-----------|-------------|-------------|
| 4~20 mA            | 16 mA      | 1.2%      | 3.808 mA    | 20.192 mA   |
| 0~20 mA            | 20 mA      |           | -0.24 mA    | 20.24 mA    |
| 1~5 V              | 4 V        |           | 0.952 V     | 5.048 V     |
| 0~5 V              | 5 V        |           | -0.06 V     | 5.06 V      |
| 0~10 V             | 10 V       |           | -0.12 V     | 10.12 V     |
| -10~10 V           | 20 V       |           | -10.24 V    | 10.24 V     |

(2) Alarm indication for each channel

Alarm detection signal is saved at UXY.20 and UXY.21. If input signal returns to the within of effective range, alarm detection signal also returns to the normal status automatically.

(X: base number, Y: slot number)

UXY.20: upper limit

|               |    |    |    |    |    |    |   |   |    |    |    |    |    |    |    |    |
|---------------|----|----|----|----|----|----|---|---|----|----|----|----|----|----|----|----|
| Bit           | 15 | 14 | 13 | 12 | 11 | 10 | 9 | 8 | 7  | 6  | 5  | 4  | 3  | 2  | 1  | 0  |
| Initial value | 0  | 0  | 0  | 0  | 0  | 0  | 0 | 0 | 0  | 0  | 0  | 0  | 0  | 0  | 0  | 0  |
| Allocation    | -  | -  | -  | -  | -  | -  | - | - | CH | CH | CH | CH | CH | CH | CH | CH |
|               |    |    |    |    |    |    |   |   | 7  | 6  | 5  | 4  | 3  | 2  | 1  | 0  |

| BIT | Description       |
|-----|-------------------|
| 0   | Normal            |
| 1   | Upper limit alarm |

UXY.21: lower limit

|               |    |    |    |    |    |    |   |   |    |    |    |    |    |    |    |    |
|---------------|----|----|----|----|----|----|---|---|----|----|----|----|----|----|----|----|
| Bit           | 15 | 14 | 13 | 12 | 11 | 10 | 9 | 8 | 7  | 6  | 5  | 4  | 3  | 2  | 1  | 0  |
| Initial value | 0  | 0  | 0  | 0  | 0  | 0  | 0 | 0 | 0  | 0  | 0  | 0  | 0  | 0  | 0  | 0  |
| Allocation    | -  | -  | -  | -  | -  | -  | - | - | CH | CH | CH | CH | CH | CH | CH | CH |
|               |    |    |    |    |    |    |   |   | 7  | 6  | 5  | 4  | 3  | 2  | 1  | 0  |

| BIT | Description       |
|-----|-------------------|
| 0   | Normal            |
| 1   | Lower limit alarm |

## Chapter 3 Installation and Wiring

### 3.1 Installation

#### 3.1.1 Installation Environment

Although this device has high reliability regardless of the environment where it is mounted, pay attention to the following conditions for reliability and stability of the system.

- (1) Environment conditions
  - (a) Mount on a water-proof and vibration proof controlling board.
  - (b) Where there are no continuous shocks or vibrations
  - (c) Where there is no direct sunlight
  - (d) Where there is no condensation caused by sudden changes of the temperature
  - (e) Where the temperature remains between 0-55°C
  
- (2) Installation work
  - (a) Do not leave wiring remnants in the PLC when boring screw holes or doing wiring work.
  - (b) Install in a place where you can easily manipulate it.
  - (c) Do not install with a high voltage device in the same panel
  - (d) Keep at least 50mm from a duct or module.
  - (e) Connect to ground where the noise environment is good.

#### 3.1.2 Precautions in Handling

This section provides information on the precautions in from opening to installing the analog conversion module.

- (1) Do not drop or hit hard.
- (2) Do not separate the PCB from the case. It may cause a failure.
- (3) Be careful not to let foreign substances such as the wiring remnants in the upper part of the module when doing the wiring work.
- (4) Do not mount or dismount when the power is on.

### 3.2 Wiring

#### 3.2.1 Precautions in Wiring

- (1) Do not put an AC power supply line near an external input signal line of an analog input module. Keep them apart enough not to be affected by the surge or induced noise from the AC side.
- (2) Consider the surrounding temperature and allowed current when choosing the cable. A cable should be larger in maximum diameter than AWG22(0.3mm<sup>2</sup>).
- (3) If the cable is placed too close to a hot device or material or put in direct contact with oil, for example, it may cause a short circuit and result in damage or malfunction.
- (4) Check the polarity when wiring the terminal block.
- (5) When cables are wired with high voltage lines or power supply cords, an induction failure may occur resulting in malfunction or a failure.

#### 3.2.2 An Example of Wiring

(1) Voltage inputs

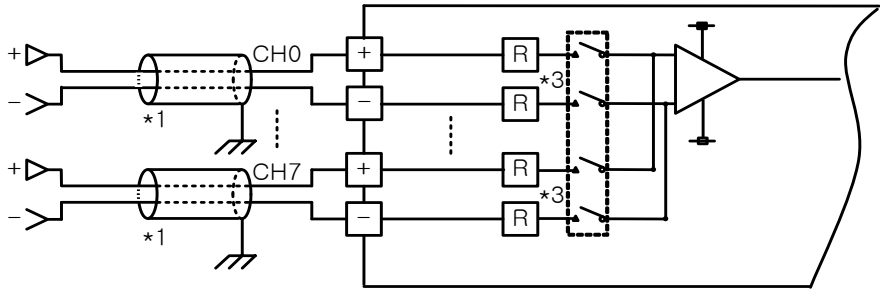

(2) Current inputs

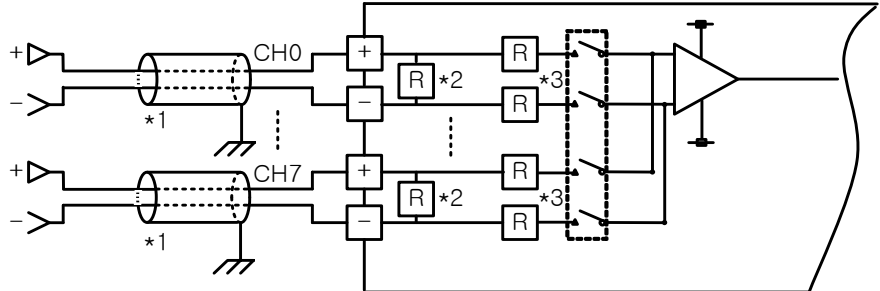

\*1) Use 2 core twist shield cable. AWG 22 is recommended for the size of the cable.  
\*2) 250 Ω (typ.) as the current input resistance of the analog input module.  
\*3) 1 MΩ (min.) as the voltage input resistance of the analog input module.

(3) An example of 2-wire sensor/transmitter wiring (current inputs)

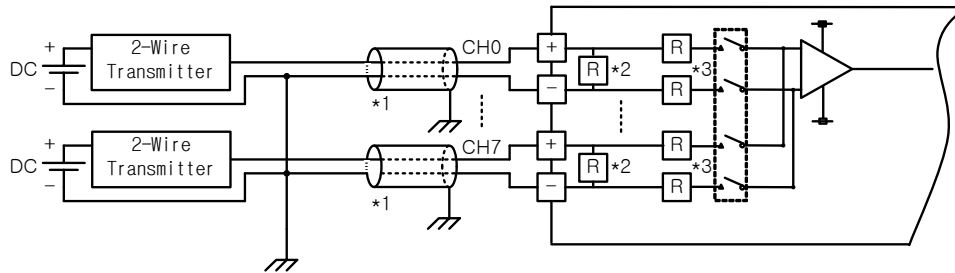

- (a) Set only the channel you are using at channel operation.
- (b) The analog input module does not supply the power for an input device. Use an external power supply.

(4) An example of 4-wire sensor/transmitter wiring (voltage and current inputs)

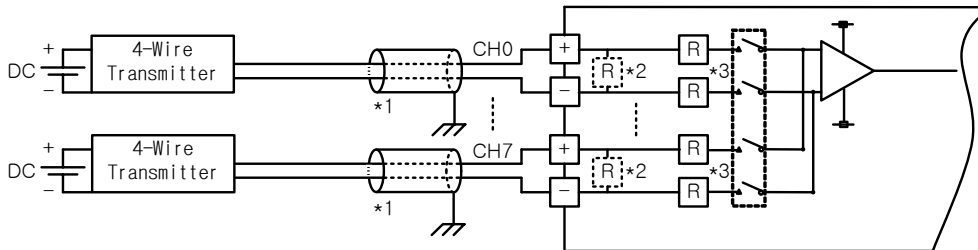

- (a) Set only the channel you are using at channel operation.
- (b) The analog input module does not supply the power for an input device. Use an external power supply.

- \*1) Use 2 core twist shield cable. AWG 22 is recommended for the size of the cable.
- \*2) 250 Ω (typ.) as the current input resistance of the analog input module.
- \*3) 1 MΩ (min.) as the voltage input resistance of the analog input module.

## (5) The relation between the voltage input precision and wiring length

The wiring length between the transmitter or sensor and the module in voltage inputs affect the digital conversion values of the module as shown below.

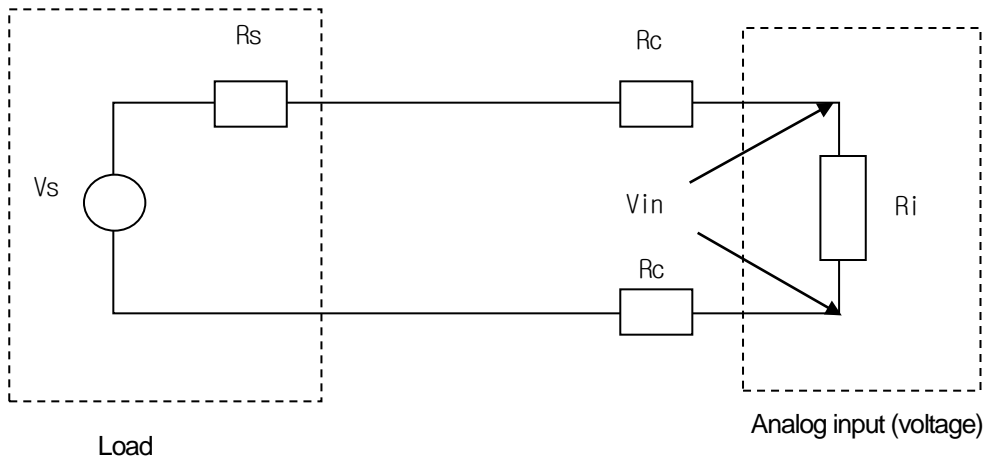

In the figure,

$R_c$ : the loop resistance of the cable

$R_s$ : the internal resistance of the transmitter or sensor

$R_i$ : the internal resistance of the module ( $1M\Omega$ ) when the voltage is input

$V_{in}$ : the voltage supplied to the analog input module

%  $V_i$ : the error (%) of the conversion values resulting from the source and cable lengths in voltage inputs

$$V_{in} = \frac{R_i \times V_s}{[R_s + (2 \times R_c) + R_i]}$$

$$\% V_i = \left(1 - \frac{V_{in}}{V_s}\right) \times 100\%$$

**Note**

There is no precision error from the cable length and the internal resistance of the source in current inputs.

## Chapter 4 Operating Setting

### 4.1 The Operating Setting Flowchart

Fig. 4.1 illustrates the operating setting flowchart.

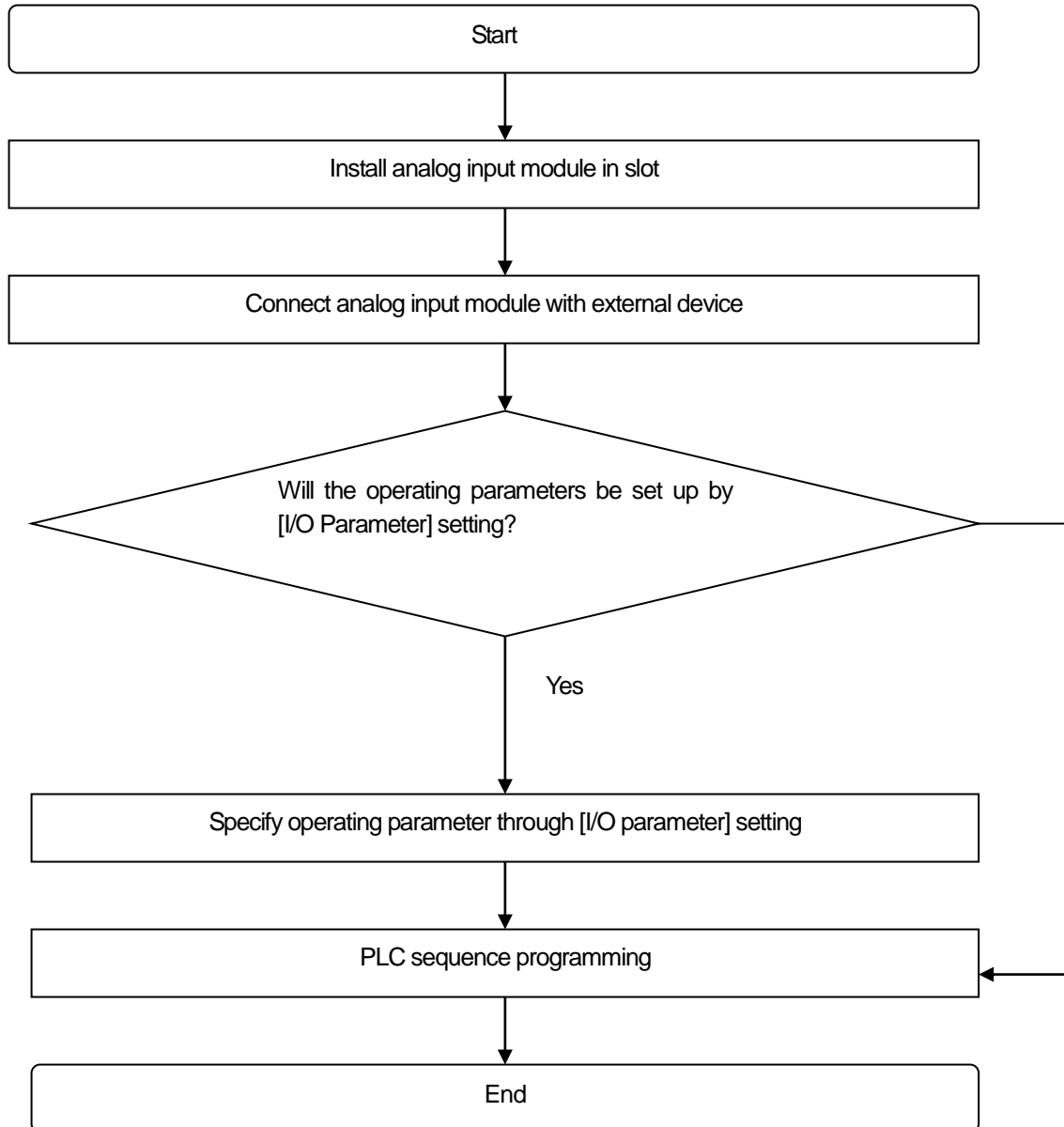

[Fig. 4. 1] Operating setting flowchart

## 4.2 Operating Parameter Setting

The operating parameters of the analog input module can be set in [I/O parameter] of XG 5000.

### 4.2.1 Setting Items

XG5000 provides GUI (Graphical User Interface) type parameter setting of the analog input module in order to enhance the user's convenience. Table 4.1 shows the parameters that can be set through [I/O parameter] in the project window of XG5000.

[Table 4. 1] Functions of [I/O parameter]

|                 | Description  |
|-----------------|--|
| [I/O parameter] | <p>(1) The following items are set that are necessary for operating the module.</p> <ul style="list-style-type: none"> <li>(a) channel run/stop</li> <li>(b) analog input range</li> <li>(c) digital output data type</li> <li>(d) average processing method</li> <li>(e) average value</li> </ul> <p>(2) The data set by the user in XG5000 is stored in the analog input module when [I/O parameter] is downloaded. That is, when [I/O parameter] is stored in the analog input module is not related to the RUN or STOP of PLC CPU.</p> |

### 4.2.2 How to Use [I/O Parameter]

- (1) Start XG5000 and create a project.  
(For how to create a project, see the program manual of XG5000)
- (2) Double-click on [I/O parameter] in the project window.

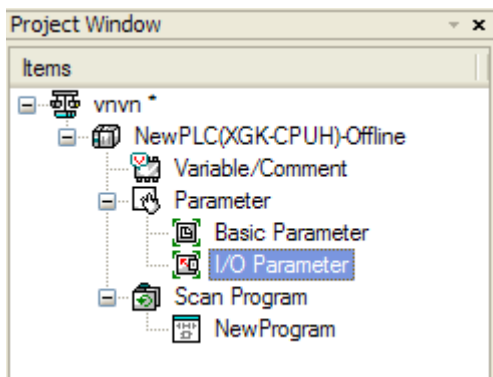

(3) Click on the slot of the base where the analog input module is mounted in the [set I/O parameter] window. In this illustration is the 8 channel voltage type analog input module mounted in slot 1, base 0.

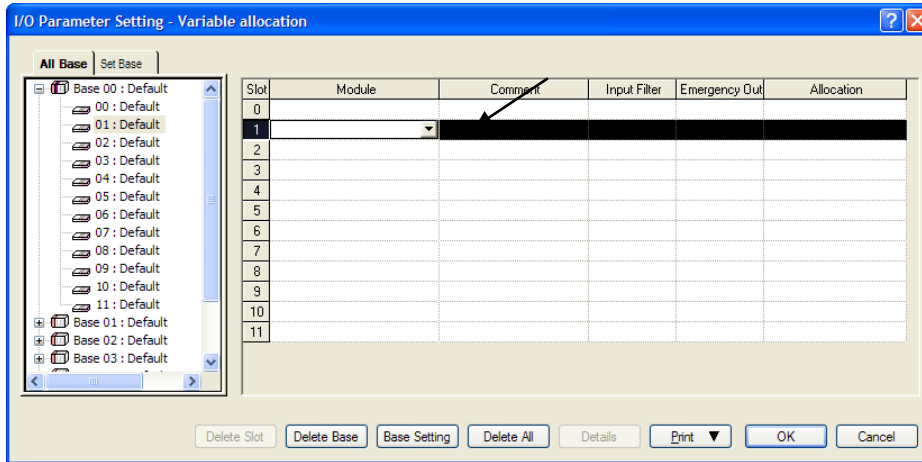

(4) Click on the arrow button and then a window will appear where you can choose a module. Find and choose a desired module.

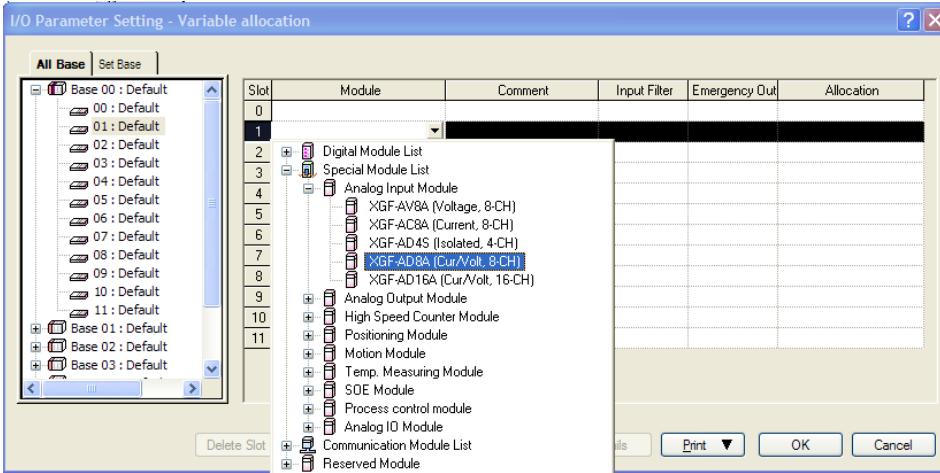

(5) Click on [Detail] button with the module chosen.

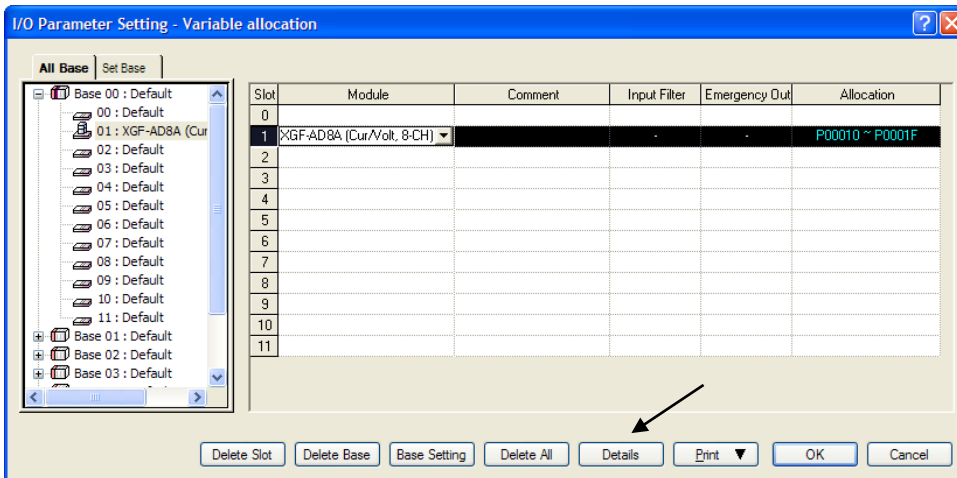

(6) A window will appear where you can set the parameters for each channel as shown below. If you click on the item you want to set, the parameters that you can set will be displayed.

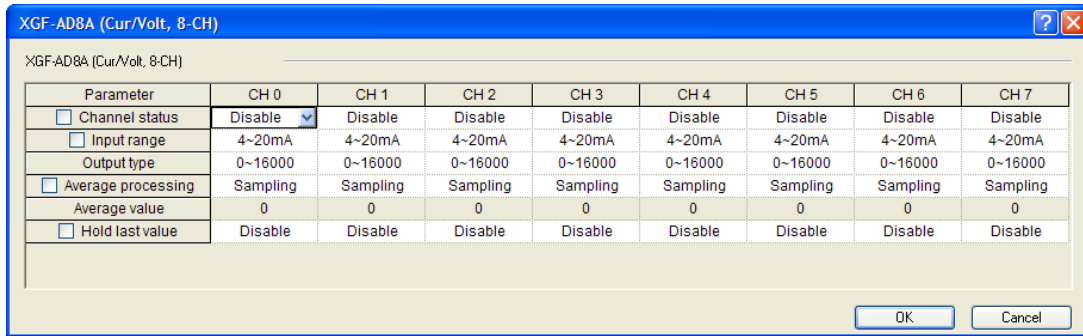

(a) Operating channel: chooses run or stop.

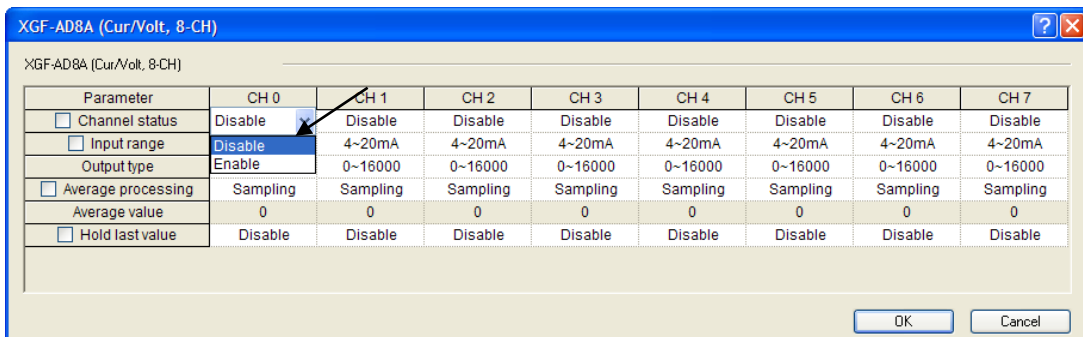

(b) Input range: chooses the range of the analog input voltage or current you want to use.  
The analog input module provides 2 current input ranges and 4 voltage input ranges.

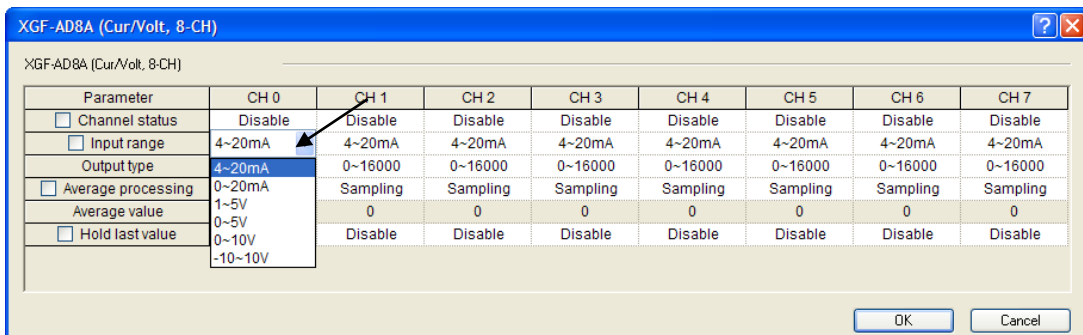

(c) The output data type: chooses the output data type. You have 4 options.

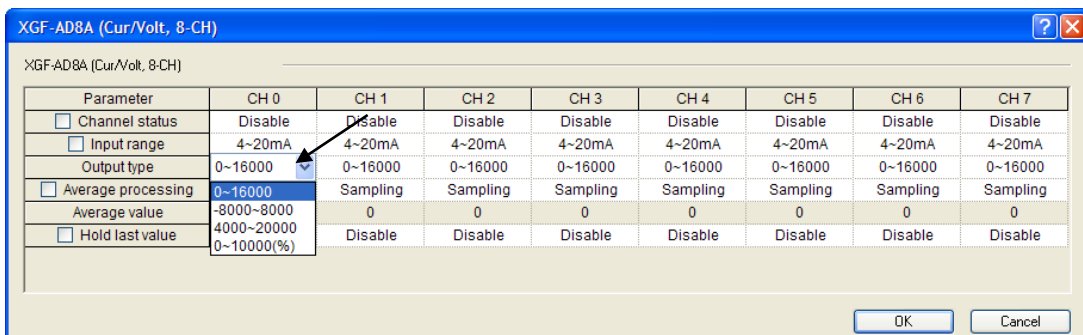

(d) Average processing: you can choose the average processing type. There are 4 options.

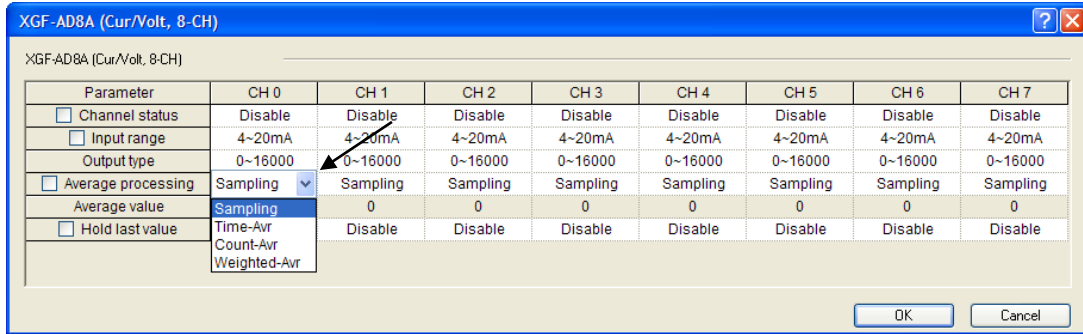

(e) Average: you can enter the average in this field only when you have set the three types (time, number and weighted averages). If you double-click on the average with one of the aforementioned three chosen, you will be able to enter a value in the field. The range of the values you can enter in the field is respectively 4~16000, 2~64000 and 0~99 for time, number and weighted averages. Any values beyond the ranges cannot be entered.

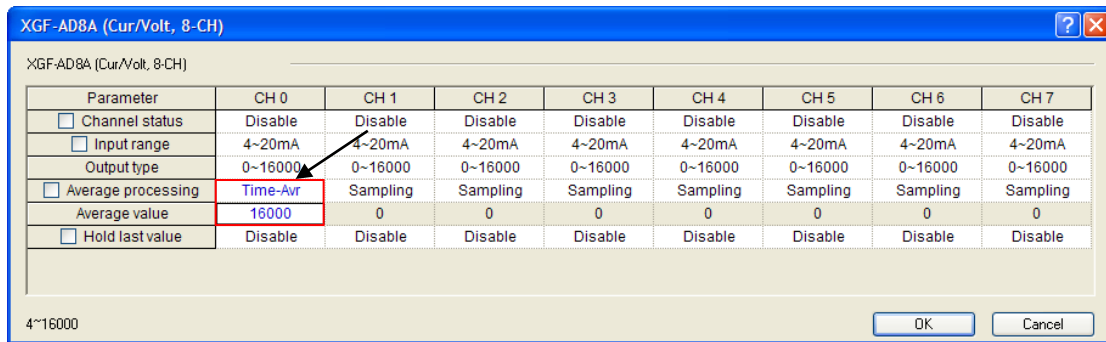

(f) Change all parameter: If you want to change all the channels to the same set value, check the radio button in the parameter row. Then, if you change the parameter of a channel, the parameters of all the channels will change at the same time. Fig. 4.2 gives an example in which the operating channel is changed to all channel operating by using this function.

[Fig. 4. 2] Change all channel parameters

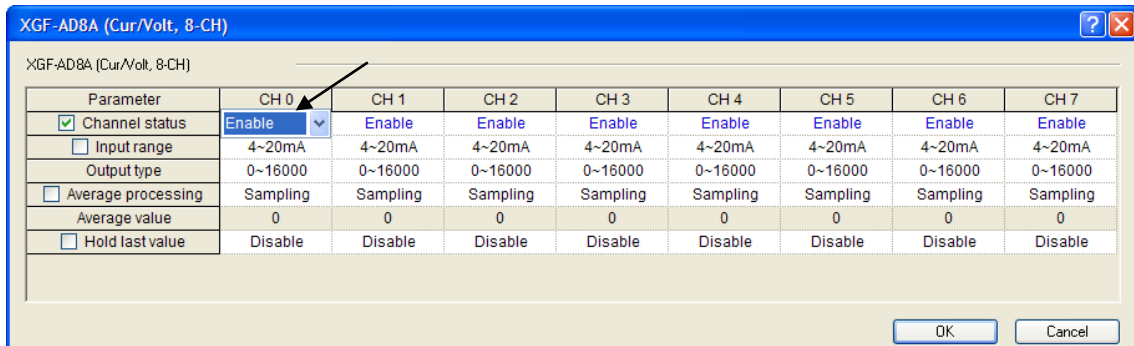

### 4.3 Functions of the Special Module Monitor

Table 4.3 shows the functions of the special module monitor.

[Table 4.3] The functions of the special module monitor

| Item                     | Description  | Note |
|--------------------------|--|------|
| [Special module monitor] | <p>(1) Monitor/test<br/>You can monitor the A/D conversion value or test the operating of the analog input module through the menu connected to [Monitor] of XG5000 -&gt; [Special module monitor].</p> <p>(2) Minimum/maximum monitor<br/>You can monitor the minimum and maximum values of a running channel. The values you can see are the current values displayed on the screen. Therefore the minimum and maximum values are not saved when you close the [Monitoring/test] window.</p> | -    |

#### Note

If there are not enough system resources of the PC you are using, the display may not be normally functioning. In such a case, close the window, end other applications and restart XG5000.

## 4.4 Precautions

- (1) The parameters you set to test the analog input module in the [Special module monitor] window are gone as soon as the [Special module monitor] window is closed. That is, the parameters of the analog input module set in the [Special module monitor] window are not saved in [I/O parameter] on the left tab of XG5000.

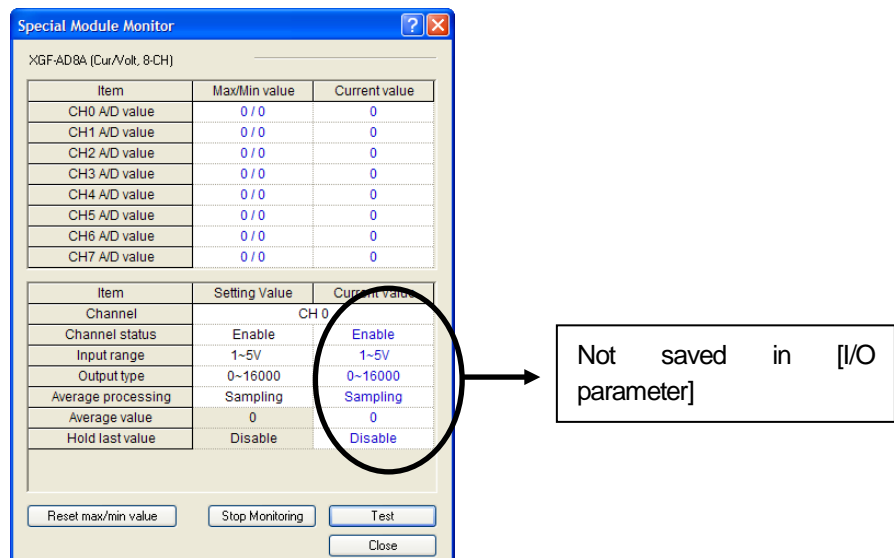

- (2) The test function of the [Special module monitor] is for checking whether the analog input module operates normally when no sequence program has been configured. If you use the analog input module for other purposes than testing, it is recommended you use the parameter setting function in [I/O parameter].

## 4.5 How to Use the Special Module Monitor

### 4.5.1 Starting [Special module monitoring]

Go [Online] -> [Access], and then [Monitor] -> [Special module monitoring]. If you are not in the [Online] status, the [Special module monitoring] menu will not be activated.

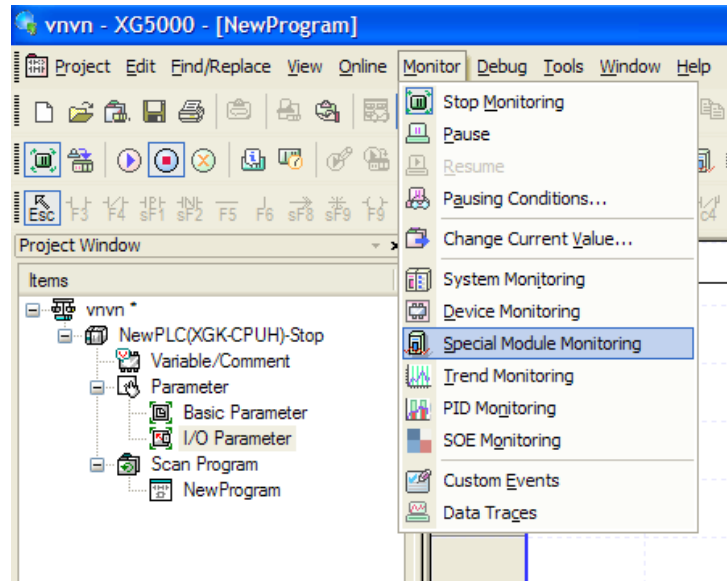

### 4.5.2 How to Use [Special module monitoring]

- (1) Click on [Monitor] -> [Special module monitoring] with XG5000 connected to the PLC CPU module. Then the [Special module list] window will appear displaying the base/slot information along with the types of the special module as in [Fig. 5.1]. The list dialog displays the module currently mounted in the PLC system.

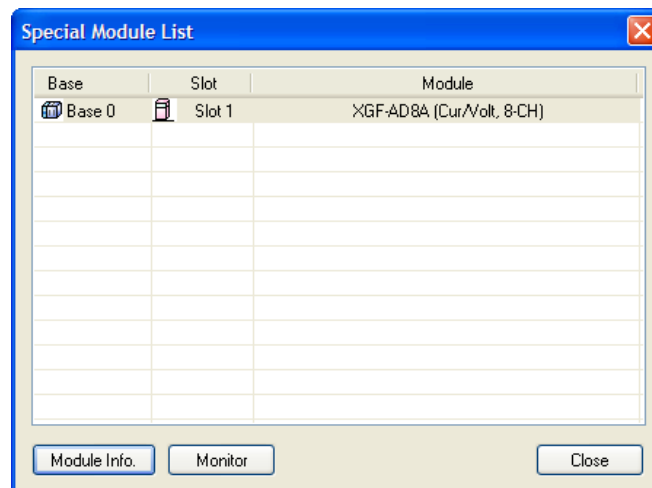

[Fig. 5.1] Special module list

(2) Select the special module and click on [Module information] in Fig. 5.1., and then the [Special module information] will appear as in Fig. 5.2.

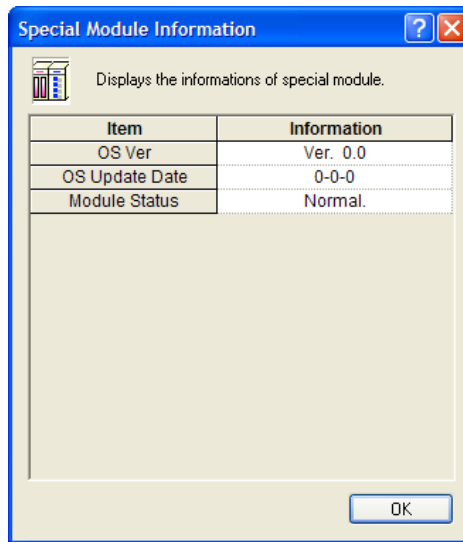

[Fig. 5.2] [Select module information]

(3) Click on the [Monitor] button in the [Special module list] in Fig. 5.1, and then the [Special module monitor] window will appear as in [Fig. 5.3].

There are 4 buttons of [Reset max/min], [Start monitoring], [Start test] and [Close] in this window. The monitor at the top of the screen displays the outputs of the analog input module and maximum/minimum values. In the test window at the bottom of the screen, you can configure the parameter items discretely of each module.

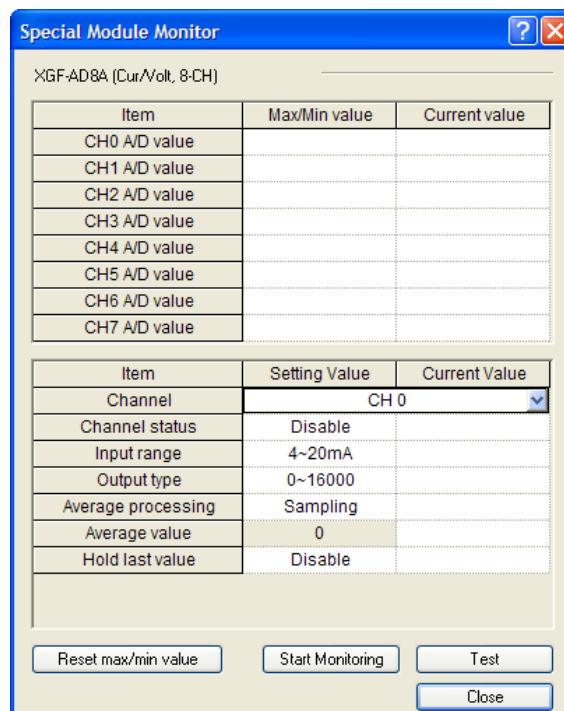

[Fig. 5.3] [Special module monitor]

- (a) [Start monitoring]: If you click on [Start monitoring], the A/D conversion value of the currently running channel will be displayed. Fig. 5.4 is the monitoring that you see when the analog input module is all channel stop status. The current value field at the bottom of the window displays the parameter of the currently set analog input module.

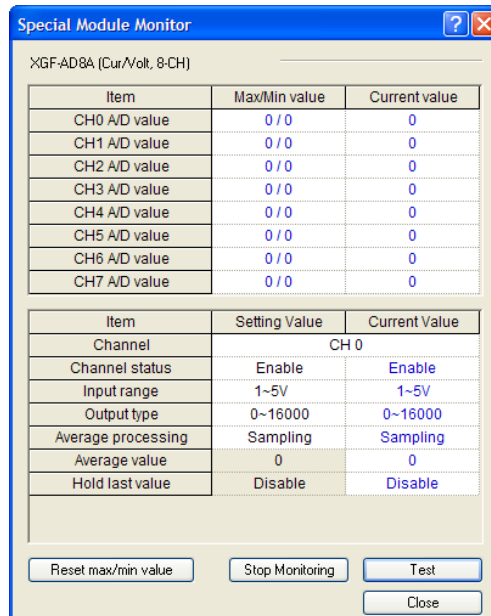

[Fig. 5.4] The display of [Start monitor]

- (b) [Test]: [Test] is used when you want to change the parameter of the currently set analog input module. You can change the parameter by clicking on the set value in the field at the bottom of the window. Fig. 5.5 is when you execute [Test] after changing the input voltage range of channel 0 to 1~5V

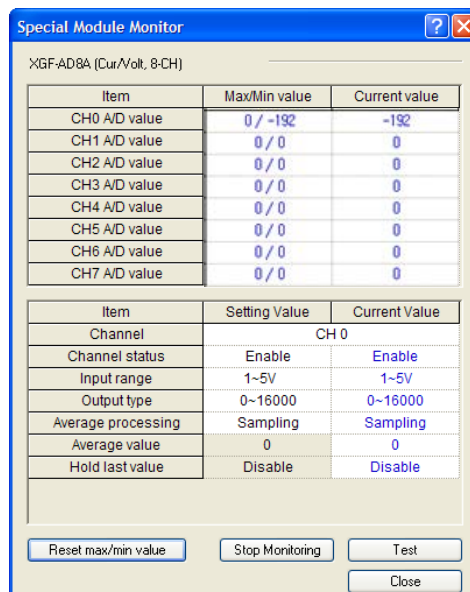

[Fig. 5.5] [Start test]

- (c) [Reset max/min value]: shows the maximum and minimum A/D conversion values at the top of the window. If you click on it, the maximum and minimum values are reset. Fig. 5.6 is when you click on [Reset max/min] in Fig. 5.5. As shown, the A/D conversion value of channel 0 has been reset.

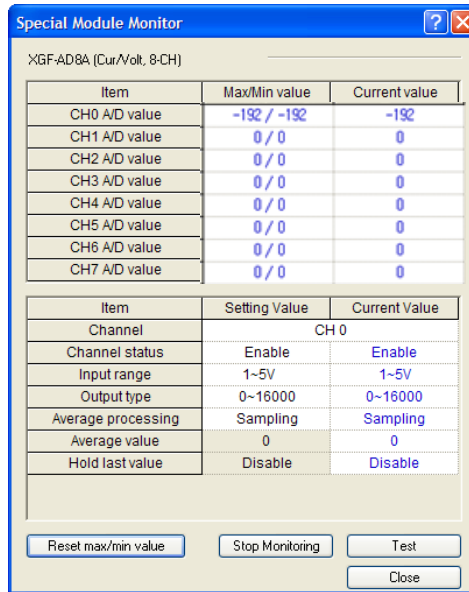

[Fig. 5.6] [Reset max/min]

(d) [Close]: used when you want to close the monitoring or test window. When you close the windows, the maximum, minimum and current values are not saved.

## 4.6 Automatic Registration of U Device

This section provides information on the automatic registration of U device of XG5000.

### 4.6.1 Automatic Registration of U Device

The variables for each module are automatically registered referring to the information of the special module set in [I/O parameter]. The user can modify the variables and the descriptions.

[Sequence]

(1) Set the special module in the slot in [I/O parameter].

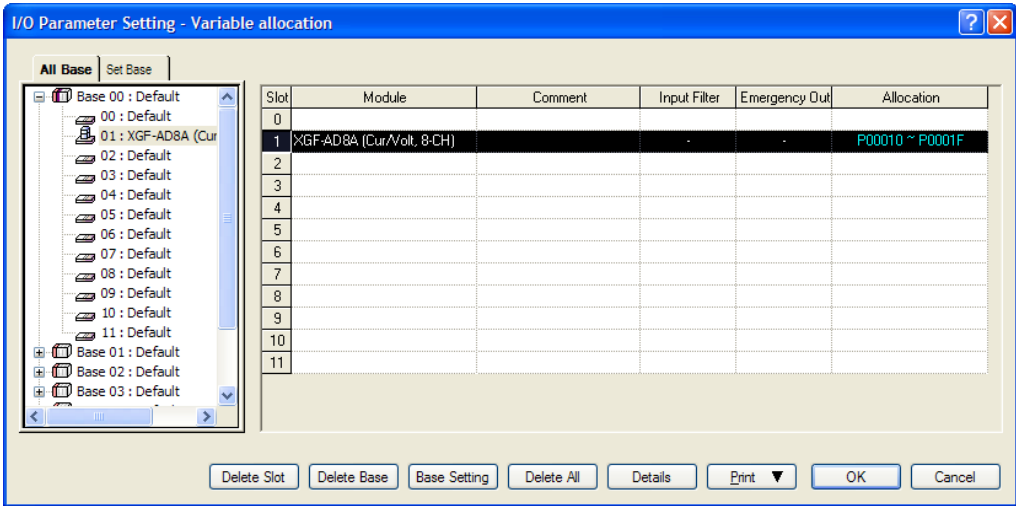

(2) Double-click on [Variable/Comment].

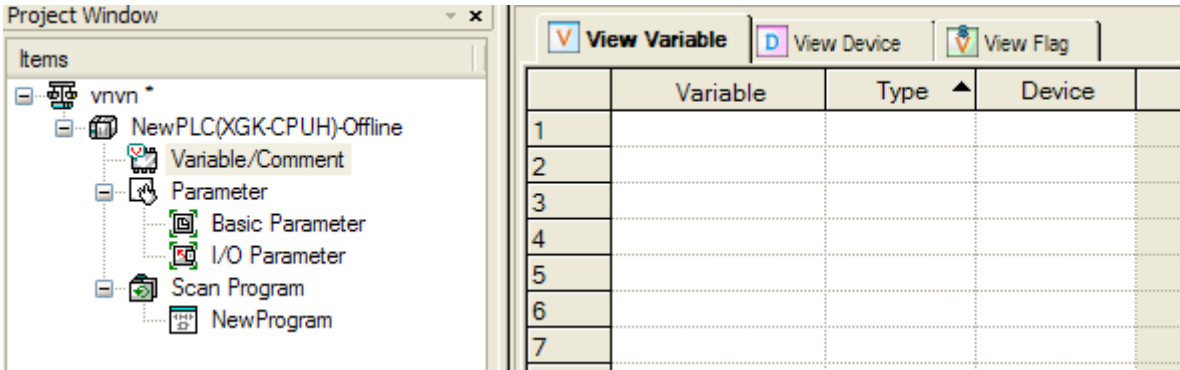

(3) Choose 'Register U Device' in [Edit] in the menu.

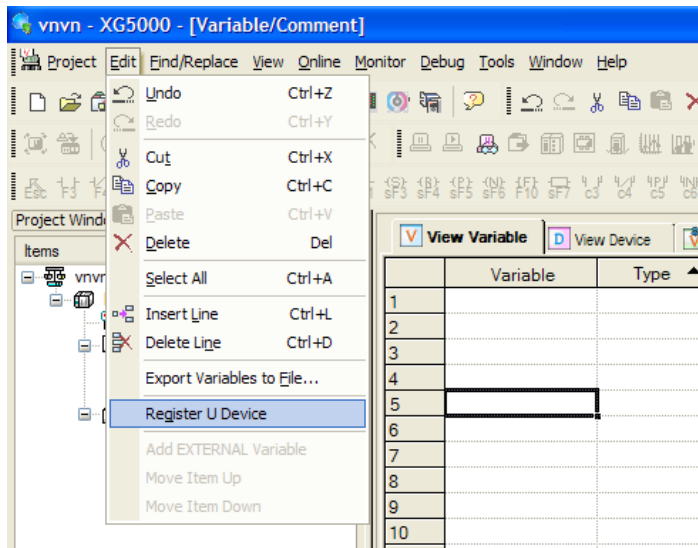

(4) Click on 'Yes.'

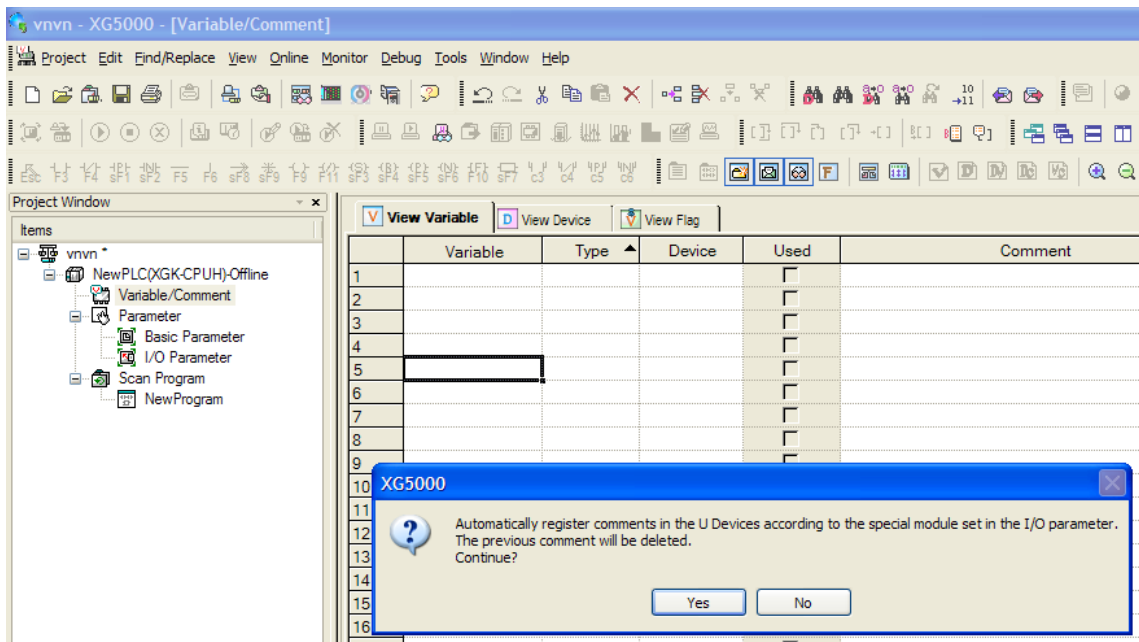

(5) The variables are registered as below.

| View Variable   View Device   View Flag |              |      |          |                          |   |
|---|--------------|------|----------|--------------------------|---|
|   | Variable     | Type | Device   | Used                     | Comment   |
| 1                                       | _01_ERR      | BIT  | U01.00.0 | <input type="checkbox"/> | Analog Input Module: Module Error                 |
| 2                                       | _01_RDY      | BIT  | U01.00.F | <input type="checkbox"/> | Analog Input Module: Module Ready                 |
| 3                                       | _01_CH0_ACT  | BIT  | U01.01.0 | <input type="checkbox"/> | Analog Input Module: CH0 Active                   |
| 4                                       | _01_CH1_ACT  | BIT  | U01.01.1 | <input type="checkbox"/> | Analog Input Module: CH1 Active                   |
| 5                                       | _01_CH2_ACT  | BIT  | U01.01.2 | <input type="checkbox"/> | Analog Input Module: CH2 Active                   |
| 6                                       | _01_CH3_ACT  | BIT  | U01.01.3 | <input type="checkbox"/> | Analog Input Module: CH3 Active                   |
| 7                                       | _01_CH4_ACT  | BIT  | U01.01.4 | <input type="checkbox"/> | Analog Input Module: CH4 Active                   |
| 8                                       | _01_CH5_ACT  | BIT  | U01.01.5 | <input type="checkbox"/> | Analog Input Module: CH5 Active                   |
| 9                                       | _01_CH6_ACT  | BIT  | U01.01.6 | <input type="checkbox"/> | Analog Input Module: CH6 Active                   |
| 10                                      | _01_CH7_ACT  | BIT  | U01.01.7 | <input type="checkbox"/> | Analog Input Module: CH7 Active                   |
| 11                                      | _01_CH0_IDD  | BIT  | U01.10.0 | <input type="checkbox"/> | Analog Input Module: CH0 Input Disconnection Flag |
| 12                                      | _01_CH1_IDD  | BIT  | U01.10.1 | <input type="checkbox"/> | Analog Input Module: CH1 Input Disconnection Flag |
| 13                                      | _01_CH2_IDD  | BIT  | U01.10.2 | <input type="checkbox"/> | Analog Input Module: CH2 Input Disconnection Flag |
| 14                                      | _01_CH3_IDD  | BIT  | U01.10.3 | <input type="checkbox"/> | Analog Input Module: CH3 Input Disconnection Flag |
| 15                                      | _01_CH4_IDD  | BIT  | U01.10.4 | <input type="checkbox"/> | Analog Input Module: CH4 Input Disconnection Flag |
| 16                                      | _01_CH5_IDD  | BIT  | U01.10.5 | <input type="checkbox"/> | Analog Input Module: CH5 Input Disconnection Flag |
| 17                                      | _01_CH6_IDD  | BIT  | U01.10.6 | <input type="checkbox"/> | Analog Input Module: CH6 Input Disconnection Flag |
| 18                                      | _01_CH7_IDD  | BIT  | U01.10.7 | <input type="checkbox"/> | Analog Input Module: CH7 Input Disconnection Flag |
| 19                                      | _01_ERR_CLR  | BIT  | U01.11.0 | <input type="checkbox"/> | Analog Input Module: Error Clear Request          |
| 20                                      | _01_CH0_HOOR | BIT  | U01.20.0 | <input type="checkbox"/> | Analog Input Module: CH0 High Out Of Range        |
| 21                                      | _01_CH1_HOOR | BIT  | U01.20.1 | <input type="checkbox"/> | Analog Input Module: CH1 High Out Of Range        |
| 22                                      | _01_CH2_HOOR | BIT  | U01.20.2 | <input type="checkbox"/> | Analog Input Module: CH2 High Out Of Range        |
| 23                                      | _01_CH3_HOOR | BIT  | U01.20.3 | <input type="checkbox"/> | Analog Input Module: CH3 High Out Of Range        |

#### 4.6.2 Saving Variables

- (1) The content in the 'View variable' tab can be saved in text files.
- (2) Click on 'Export into text file' in 'Edit' in the menu.
- (3) The content in the 'View variable' tab is saved in a text file.

### 4.6.3 Viewing Variables in the Program

(1) The example program of XG5000 is as follows.

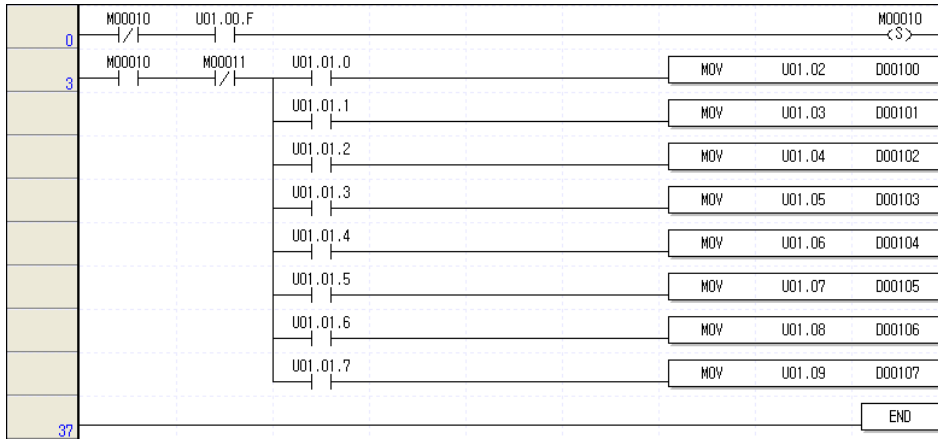

(2) Click on 'Variables' in 'View' in the menu. The devices become variables.

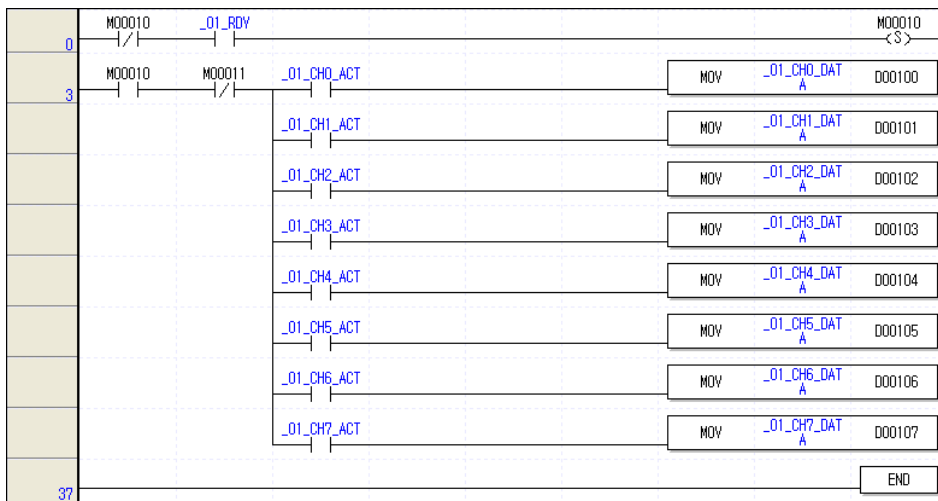

(3) Click on 'Devices/Variables' in 'View' in the menu. You can view the device and variable together at a time.

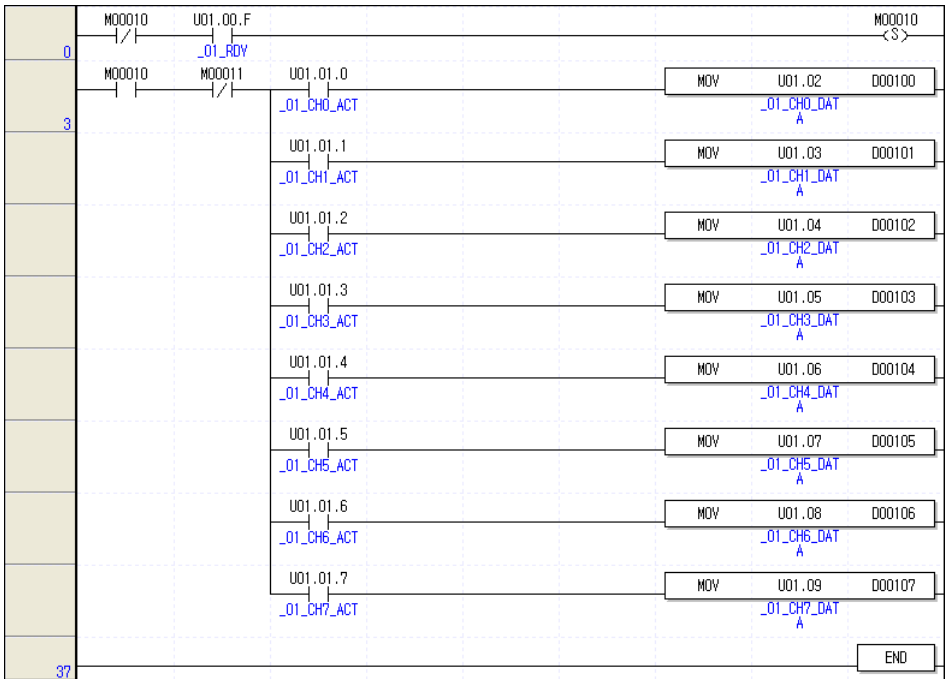

(4) Click on 'Devices/Comments' in 'View' in the menu. You can view the device and comment together at a time.

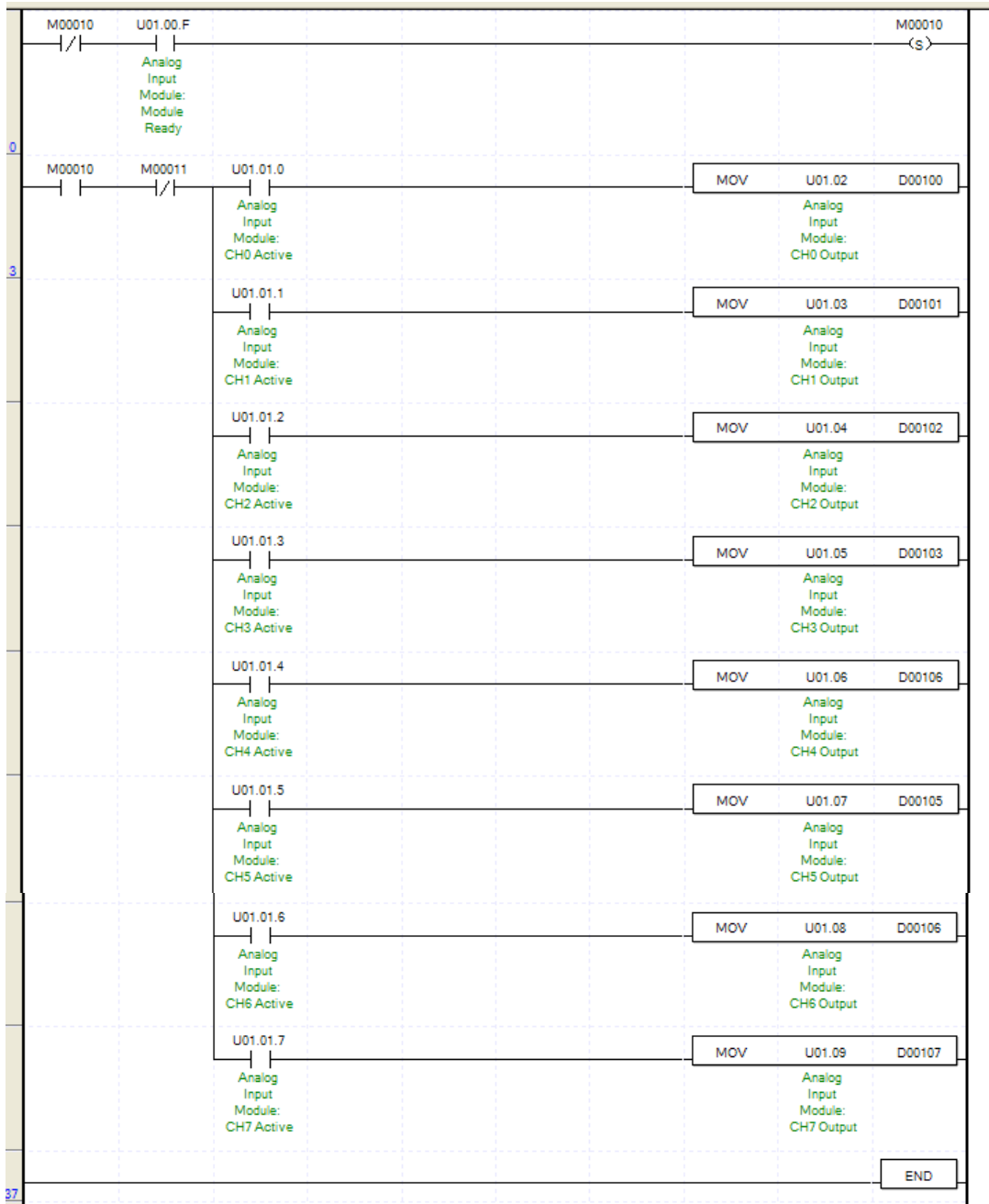

(5) Click on 'Variables/Comments' in 'View' in the menu. You can view the variables and comments together at a time.

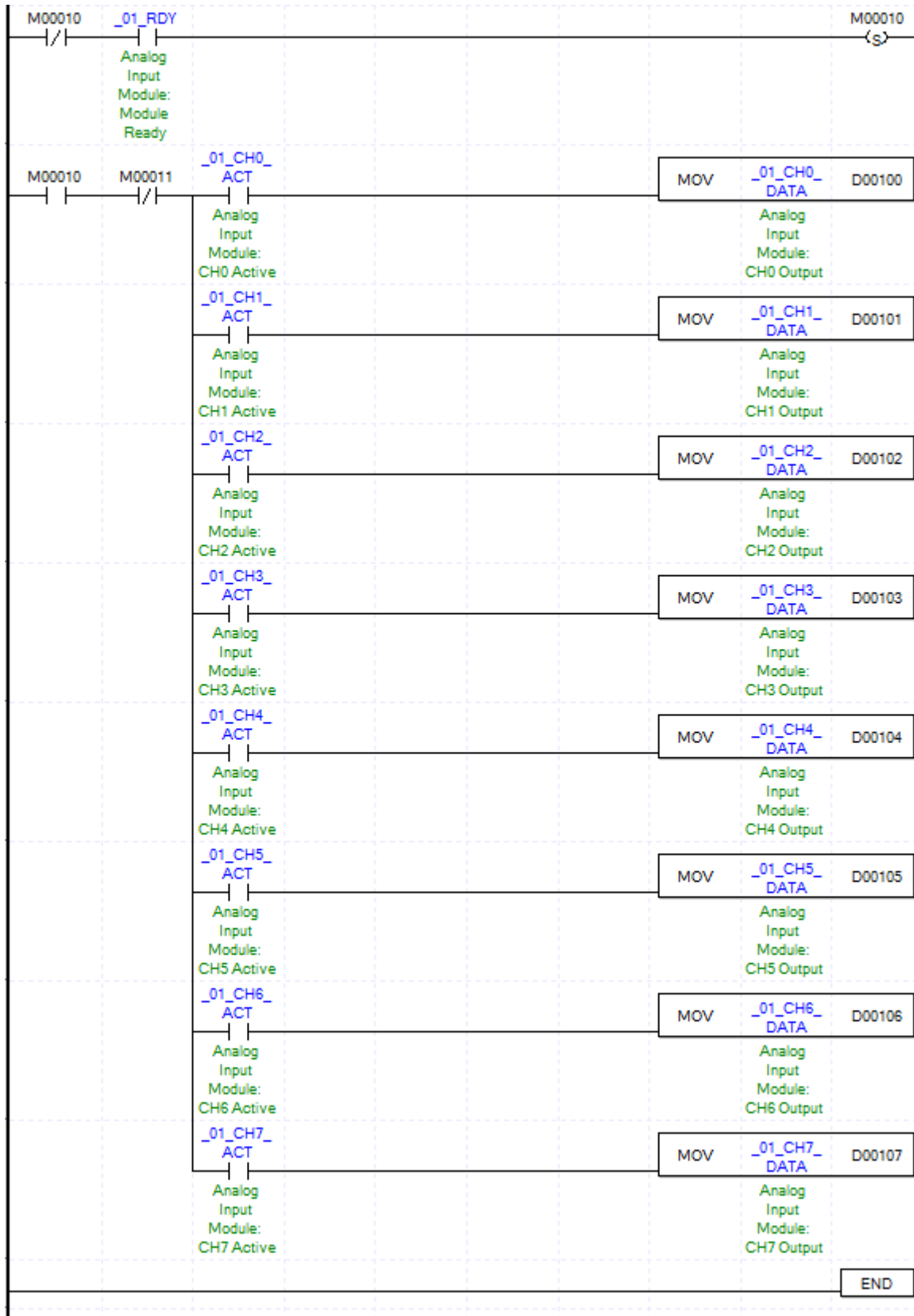

## Chapter 5 Configuration and Functions of Internal Memory (For XGK)

The analog input module has an internal memory for transmitting and receiving data with the PLC CPU.

### 5.1 The Configuration of the Internal Memory

This section gives information on the configuration of the internal memory.

#### 5.1.1 Input and Output Areas of A/D Conversion Data

Table 5.1 shows the input and output ranges of the analog input data.

[Table 5. 1] Input and output ranges of analog input data

| Device allocation  | Description  | Read/write | Signal direction | Ref. |
|--|--|------------|------------------|------|
| UXY.00.0<br>UXY.00.F   | module ERROR flag<br>module READY flag   | Read       | A/D → CPU        |      |
| UXY.01.0<br>UXY.01.1<br>UXY.01.2<br>UXY.01.3<br>UXY.01.4<br>UXY.01.5<br>UXY.01.6<br>UXY.01.7 | channel0 operating flag<br>channel1 operating flag<br>channel2 operating flag<br>channel3 operating flag<br>channel4 operating flag<br>channel5 operating flag<br>channel6 operating flag<br>channel7 operating flag   | Read       | A/D → CPU        |      |
| UXY.02   | Channel 0 digital output value   | Read       | A/D → CPU        |      |
| UXY.03   | Channel 1 digital output value   |            |                  |      |
| UXY.04   | Channel 2 digital output value   |            |                  |      |
| UXY.05   | Channel 3 digital output value   |            |                  |      |
| UXY.06   | Channel 4 digital output value   |            |                  |      |
| UXY.07   | Channel 5 digital output value   |            |                  |      |
| UXY.08   | Channel 6 digital output value   |            |                  |      |
| UXY.09   | Channel 7 digital output value   |            |                  |      |
| UXY.10.0<br>UXY.10.1<br>UXY.10.2<br>UXY.10.3<br>UXY.10.4<br>UXY.10.5<br>UXY.10.6<br>UXY.10.7 | channel0 disconnection detection flag(1 ~ 5 V OR 4 ~ 20 mA)<br>channel1 disconnection detection flag(1 ~ 5 V OR 4 ~ 20 mA)<br>channel2 disconnection detection flag(1 ~ 5 V OR 4 ~ 20 mA)<br>channel3 disconnection detection flag(1 ~ 5 V OR 4 ~ 20 mA)<br>channel4 disconnection detection flag(1 ~ 5 V OR 4 ~ 20 mA)<br>channel5 disconnection detection flag(1 ~ 5 V OR 4 ~ 20 mA)<br>channel6 disconnection detection flag(1 ~ 5 V OR 4 ~ 20 mA)<br>channel7 disconnection detection flag(1 ~ 5 V OR 4 ~ 20 mA) | Read       | A/D → CPU        |      |
| UXY.11.0   | Error clear request flag   | Write      | CPU → A/D        |      |

| Device allocation  | Description  | Read/write | Signal direction | Ref.                      |
|--|--|------------|------------------|---------------------------|
| UXY.20.0<br>UXY.20.1<br>UXY.20.2<br>UXY.20.3<br>UXY.20.4<br>UXY.20.5<br>UXY.20.6<br>UXY.20.7 | CH0 alarm upper limit<br>CH1 alarm upper limit<br>CH2 alarm upper limit<br>CH3 alarm upper limit<br>CH4 alarm upper limit<br>CH5 alarm upper limit<br>CH6 alarm upper limit<br>CH7 alarm upper limit | Read       | A/D → CPU        | More than OS version 1.02 |
| UXY.21.0<br>UXY.21.1<br>UXY.21.2<br>UXY.21.3<br>UXY.21.4<br>UXY.21.5<br>UXY.21.6<br>UXY.21.7 | CH0 alarm lower limit<br>CH1 alarm lower limit<br>CH2 alarm lower limit<br>CH3 alarm lower limit<br>CH4 alarm lower limit<br>CH5 alarm lower limit<br>CH6 alarm lower limit<br>CH7 alarm lower limit | Read       | A/D → CPU        | More than OS version 1.02 |

- (1) In device allocation, X means the number of the base where the module is mounted and Y the number of the slot where the module is mounted
- (2) The 'channel1 digital output value' of the analog input module mounted in base 0 slot 4 is expressed as U04.03.

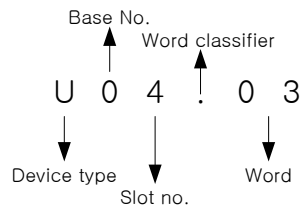

- (a) Base number setting range: 0 ~ 7
- (b) Slot number setting range: 0 ~ 15

- (3) The channel 4 disconnection detection flag of the analog input module mounted in base 0 slot 5 is expressed as U05.10.4.

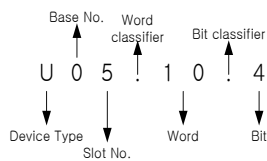

### 5.1.2 Operating Parameter Setting Range

**Note**

The operating parameter of the analog input module can be set through [I/O parameter] of XG5000. XG5000 provides the GUI (Graphical User Interface) type parameter setting of the analog input module in order to enhance the user's convenience of the analog input module.

Table 5.2 shows the operating parameter setting range of the analog input module.

[Table 5. 2] Operating parameter setting ranges

| Memory address |         | Description                    | Read/write |
|----------------|---------|--------------------------------|------------|
| Hexadecimal    | Decimal |                                |            |
| 0H             | 0       | Specifies the channel in use   | Read/write |
| 1H             | 1       | Input voltage/current ranges 1 |            |
| 2H             | 2       | Input voltage/current ranges 2 |            |
| 3H             | 3       | Output data range              | Read/write |
| 4H             | 4       | Average processing             |            |
| 5H             | 5       | Channel 0 average              |            |
| 6H             | 6       | Channel 1 average              |            |
| 7H             | 7       | Channel 2 average              |            |
| 8H             | 8       | Channel 3 average              |            |
| 9H             | 9       | Channel 4 average              |            |
| AH             | 10      | Channel 5 average              |            |
| BH             | 11      | Channel 6 average              |            |
| CH             | 12      | Channel 7 average              |            |
| DH             | 13      | Error code                     | Read       |
| EH             | 14      | Hold last value                | Read/Write |

## 5.2 A/D Conversion Data Input/Output Ranges

### 5.2.1 Module READY/ERROR Flag (UXY.00, X: base number, Y: slot number)

- (1) **UXY.00.F**: On when the A/D conversion is ready with the PLC CPU supplied with power or reset, and conducts A/D conversion.
- (2) **UXY.00.0**: the flag displaying errors of the analog input module

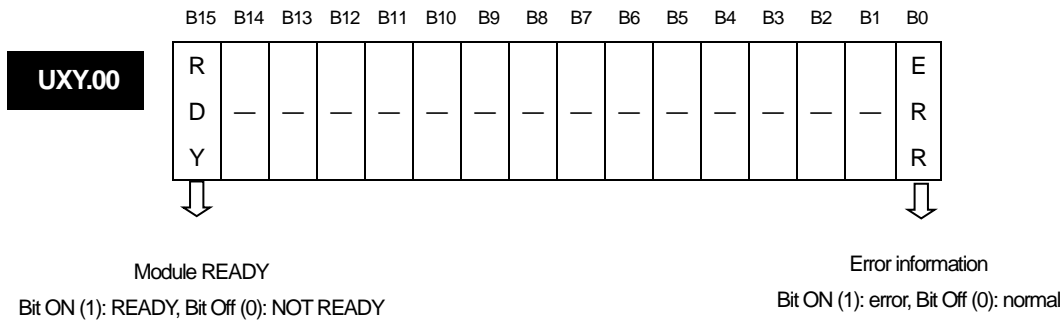

### 5.2.2 Operating channel flag (UXY.01, X: base number, Y: slot number)

This is the area where the operating information for each channel is stored.

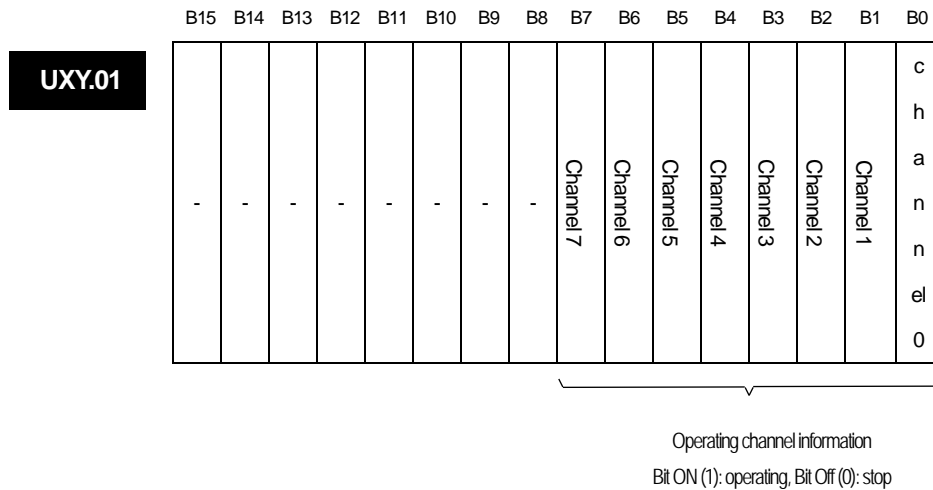

**5.2.3 Digital output value (UXY.02 ~ UXY.09, X: base number, Y: slot number)**

- (1) The A/D converted digital output value is output for each channel in the buffer memory address 2 ~ 9(UXY.02 ~ UXY.09).
- (2) The digital output values are saved in binary numbers of 16 bit.

**UXY.02 ~ UXY.17**

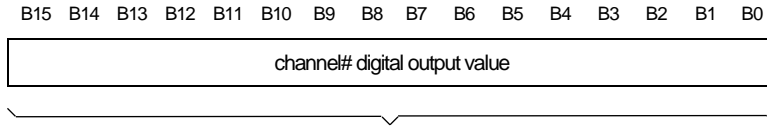

| Address | Description                   |
|---------|-------------------------------|
| 2       | channel0 digital output value |
| 3       | channel1 digital output value |
| 4       | channel2 digital output value |
| 5       | channel3 digital output value |
| 6       | channel4 digital output value |
| 7       | channel5 digital output value |
| 8       | channel6 digital output value |
| 9       | channel7 digital output value |

**5.2.4 Disconnection detection flag (UXY.10.Z, X: base number, Y: slot number, Z: channel number)**

- (1) The disconnection detection signals for each input channel is stored in UXY.18.
- (2) Each bit is set as 1 when a disconnection is detected for the allocated channel, and turns into 0 when the disconnection is recovered. Each bit can be used for disconnection detection in the user program as the operating conditions.

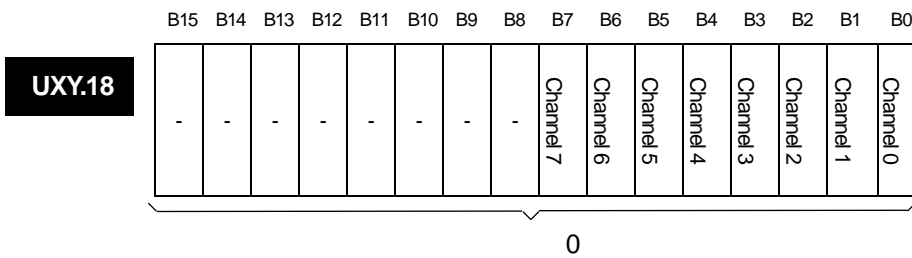

| BIT | Description   |
|-----|---------------|
| 0   | Normal        |
| 1   | Disconnection |

**5.2.5 Error clear request flag (UXY.11.0, X: base number, Y: slot number)**

- (1) When there is a parameter setting error, the error code of address 22 is not automatically deleted even if you change the parameter to a correct value. If you turn on the error clear request bit, the error displayed in [System monitor] of XG5000 is deleted. RUN LED also turns to On from Flashing.
- (2) You have to use the error clear request flag along with UXY.00.0 for normal operating as shown in Fig. 5.1.

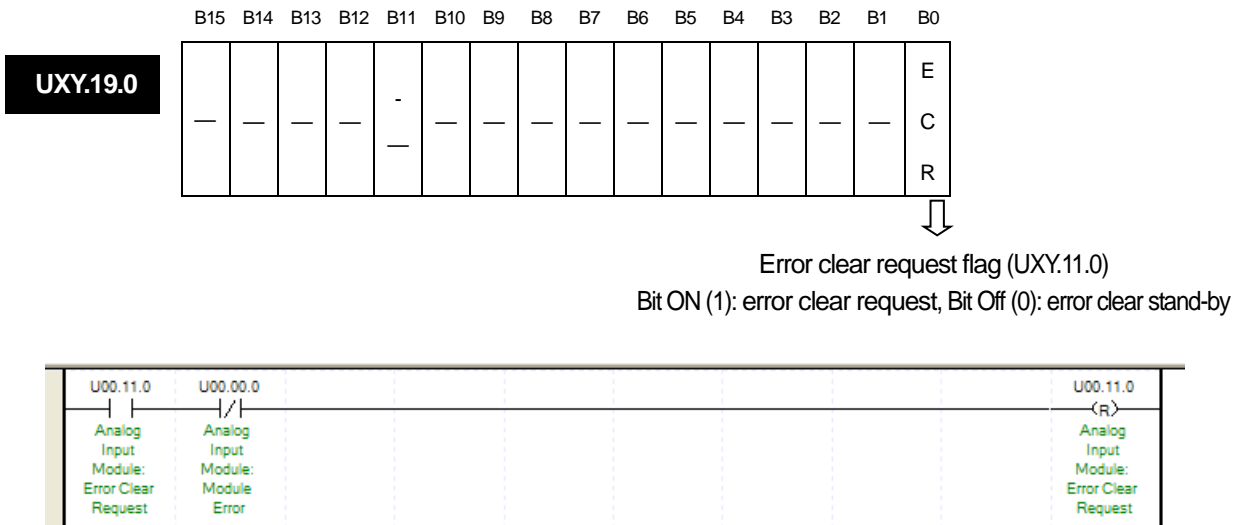

[Fig. 5. 1] How to use the error clear request flag

### 5.3 Operating Parameter Setting Ranges

Each address of the internal memory is occupied by 1 word, which can be expressed in 16 bit. Each function can be used by setting the 16 bit that comprises the address at 1 when On for each bit and at 0 when Off for each bit.

#### 5.3.1 Designation of the channel to use (address 0)

- (1) You can set whether to allow/block A/D conversion for each channel.
- (2) You can shorten the conversion cycle for channels by blocking conversion of the channel you don't use.
- (3) When no channel is designated for use, all the channels are set as not used.
- (4) Allow/block of A/D conversion is as follows.

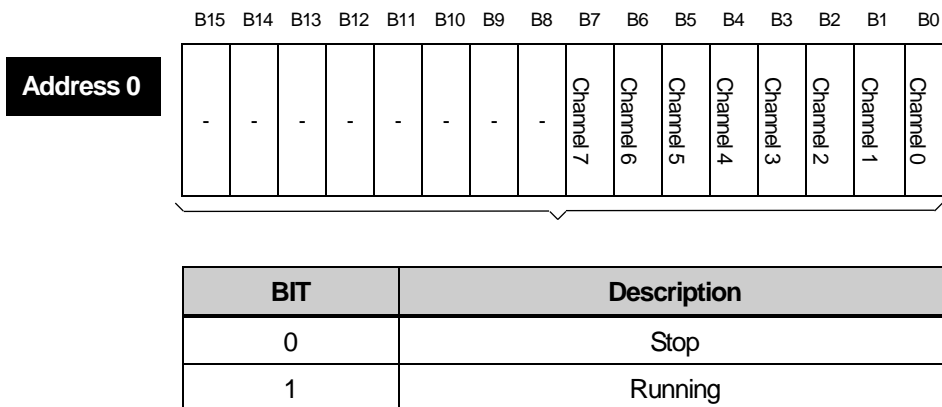

### 5.3.2 Output Voltage/Current Ranges (Addresses 1~4)

- (1) You can set the ranges of the analog input voltage/current for each channel.
- (2) When no analog input range is specified, all the channels are set as 4 ~ 20 mA.
- (3) The ranges of the analog input voltage/current are set as follows.

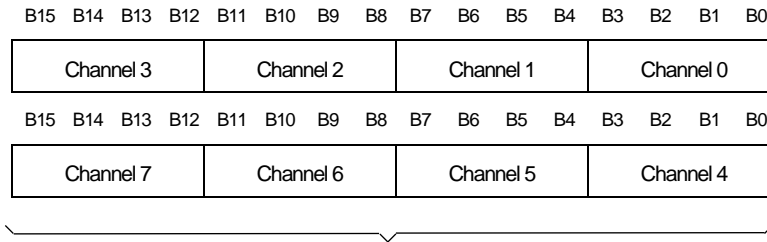

| BIT  | Description  |
|------|--------------|
| 0000 | 4 mA ~ 20 mA |
| 0001 | 0 mA ~ 20 mA |
| 0010 | 1 V ~ 5 V    |
| 0011 | 0 V ~ 5 V    |
| 0100 | 0 V ~ 10 V   |
| 0101 | -10 V ~ 10 V |

### 5.3.3 Output Data Ranges (Address 3)

- (1) You can set the ranges of the digital output data for analog input for each channel
- (2) When no output data range is specified, all the channels are set as 0 ~ 16000.
- (3) The ranges of the digital output data are as follows.

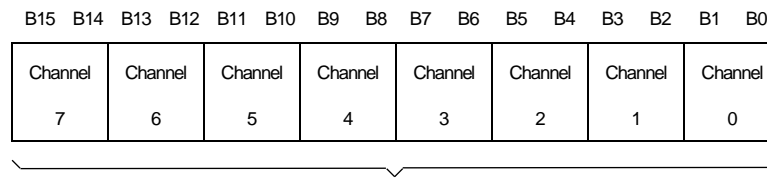

| BIT | Description   |
|-----|---------------|
| 00  | 0 ~ 16000     |
| 01  | -8000 ~ 8000  |
| 10  | Precise Value |
| 11  | 0 ~ 10000     |

The precise values have the following digital output ranges for the analog input range.

(a) Current

|                |              |           |
|----------------|--------------|-----------|
| Analog input   | 4 ~ 20 mA    | 0 ~ 20 mA |
| Digital output |              |           |
| Precise Value  | 4000 ~ 20000 | 0 ~ 20000 |

(b) Voltage

|                |                |           |          |             |
|----------------|----------------|-----------|----------|-------------|
| Analog input   | -10 ~ 10 V     | 0 ~ 10 V  | 0 ~ 5 V  | 1 ~ 5 V     |
| Digital output |                |           |          |             |
| Precise Value  | -10000 ~ 10000 | 0 ~ 10000 | 0 ~ 5000 | 1000 ~ 5000 |

### 5.3.4 Average Processing (Address 4)

- (1) This is the area where you designate the method of average processing. Average processing divides into 'number average' and 'time average.'
- (2) When you designate no average processing, all the channels conduct sampling processing.
- (3) The designation of average processing is as follows.

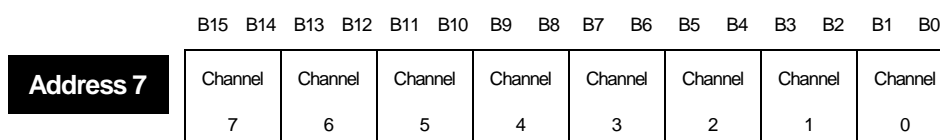

| BIT | Description         |
|-----|---------------------|
| 00  | Sampling processing |
| 01  | Time average        |
| 10  | Number average      |
| 11  | Weighted average    |

### 5.3.5 Average Value (Addresses 5~12)

- (1) The setting ranges of the time/number/weighted averages are as follows.
  - (a) Time average: 16 ~ 16000(ms)
  - (b) Number average: 2 ~ 64000(number of times)
  - (c) Weighted average: 1 ~ 99(%)
- (2) If you designate a value beyond the range, the address that displays the error code shows the following signals.
  - (a) Beyond the time average range: error code #50
  - (b) Beyond the number average range: error code 60#
  - (c) Beyond the weighted average range: error code 70\$

In these cases, the initial value applies to the average processing.  
 (# of the error code means the channel where the error occurred)

(3) The setting of time/number/weighted averages processing values is as follows.

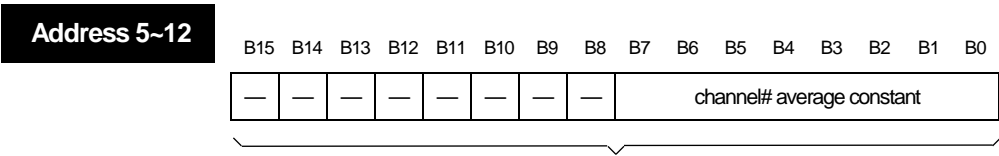

The setting range of the time average: 16 ~ 16000

The setting range of the number average: 2 ~ 64000

The setting range of the weighted average: 1 ~ 99

| Address    | Description                                    |
|------------|--|
| Address 5  | Sets the average processing value of channel 0 |
| Address 6  | Sets the average processing value of channel 1 |
| Address 7  | Sets the average processing value of channel 2 |
| Address 8  | Sets the average processing value of channel 3 |
| Address 9  | Sets the average processing value of channel 4 |
| Address 10 | Sets the average processing value of channel 5 |
| Address 11 | Sets the average processing value of channel 6 |
| Address 12 | Sets the average processing value of channel 7 |

### 5.3.6 Error Code (Address 13)

- (1) This saves the error code detected by the analog input module.
- (2) The types and descriptions of the errors are as follows.

Address 13

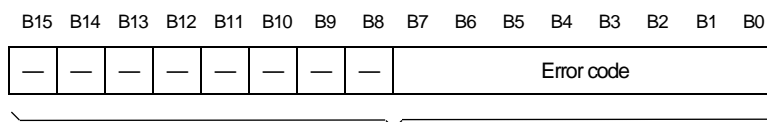

For the details of the error codes, see the table below.

| Error code<br>(Decimal) | Description of the error   | Note                                |
|-------------------------|--|-------------------------------------|
| 0                       | Normal operation   | RUN LED on                          |
| 11                      | module error (ASIC RAM or Register Error)  | RUN LED flashes every<br>0.2 second |
| 20                      | module error (A/D Conversion Error)  |                                     |
| 40##                    | module error (The offset value of 4 ~ 20 mA is larger than or equal to the gain value)   | RUN LED flashes every<br>second     |
| 41##                    | module error (The offset value of 0 ~ 20 mA is larger than or equal to the gain value.)  |                                     |
| 42##                    | module error (The offset value of 1 ~ 5 V is larger than or equal to the gain value.)    |                                     |
| 43##                    | module error (The offset value of 0 ~ 5 V is larger than or equal to the gain value.)    |                                     |
| 44##                    | module error (The offset value of 0 ~ 10 V is larger than or equal to the gain value.)   |                                     |
| 45##                    | module error (The offset value of -10 ~ 10 V is larger than or equal to the gain value.) |                                     |
| 50##                    | Beyond the time average setting range  |                                     |
| 60##                    | Beyond the number average setting range  |                                     |
| 70##                    | Beyond the weighted average setting range  |                                     |

- ※ # of the error code means the channel where the error occurred.
- ※ For details of the error codes, see 9.1.

- (3) If there are two or more errors, the module saves the error code that happened first and does not save the following error codes.
- (4) If there is an error, you should use the error clear request flag (see 5.2.5) or turn the power supply Off → On after the error is corrected so that the LED stops flashing and the error code is deleted.

5.3.7 Hold last value (Address 14)

- (1) If you enable this function, when input value exceeds the effective range, holds the last value. For example, in case of 4~20mA, if input signal change from 10mA to 3mA shortly, channels holds output value corresponding to 10mA.
- (2) If this function is enabled, channel indicates digital output value within effective range. For effective range, refer to chapter 2.4 I/O conversion characteristic.
- (3) This function is available in the following input range.
  - (a) 4 ~ 20 mA
  - (b) 0 ~ 20 mA
- (4) Setting is as follows.

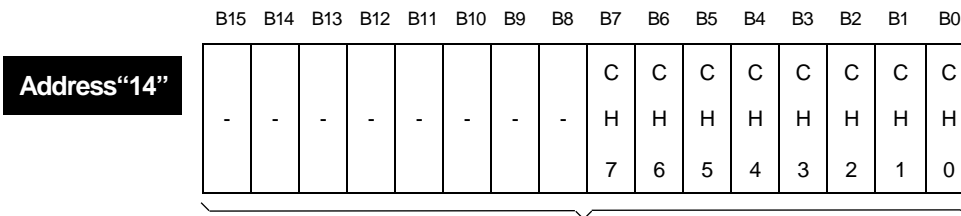

| BIT | Description |
|-----|-------------|
| 0   | Disable     |
| 1   | Enable      |



## Chapter 6 Programming (For XGK)

### 6.1 The Basic Program

- This chapter provides information on how to set the operating conditions for the internal memory of the analog input module.
- The analog input module is mounted in slot 2.
- The input and output occupancy point of the analog input module is 16 points (variable).
- The initial setting condition is one time entry. The setting of the initial value is saved in the internal memory of the analog input module.

#### 6.1.1 An Example of a Program That Uses [I/O Parameter]

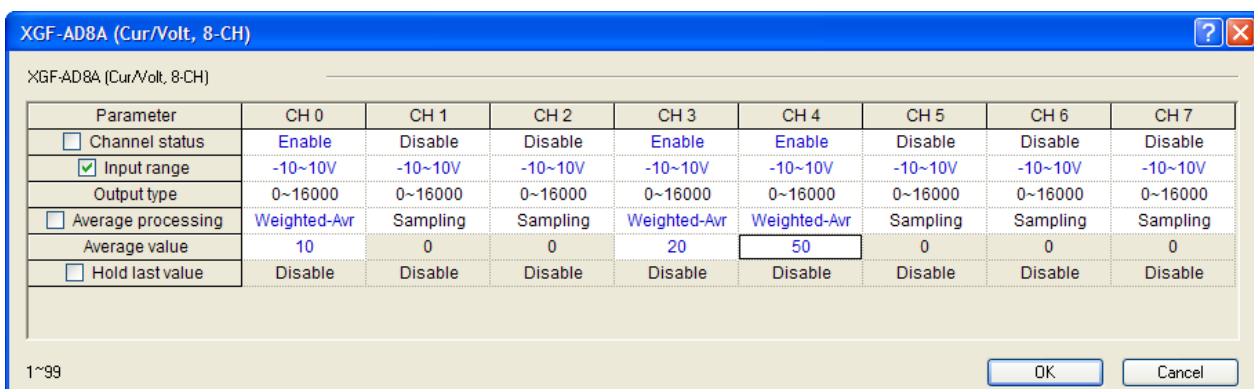
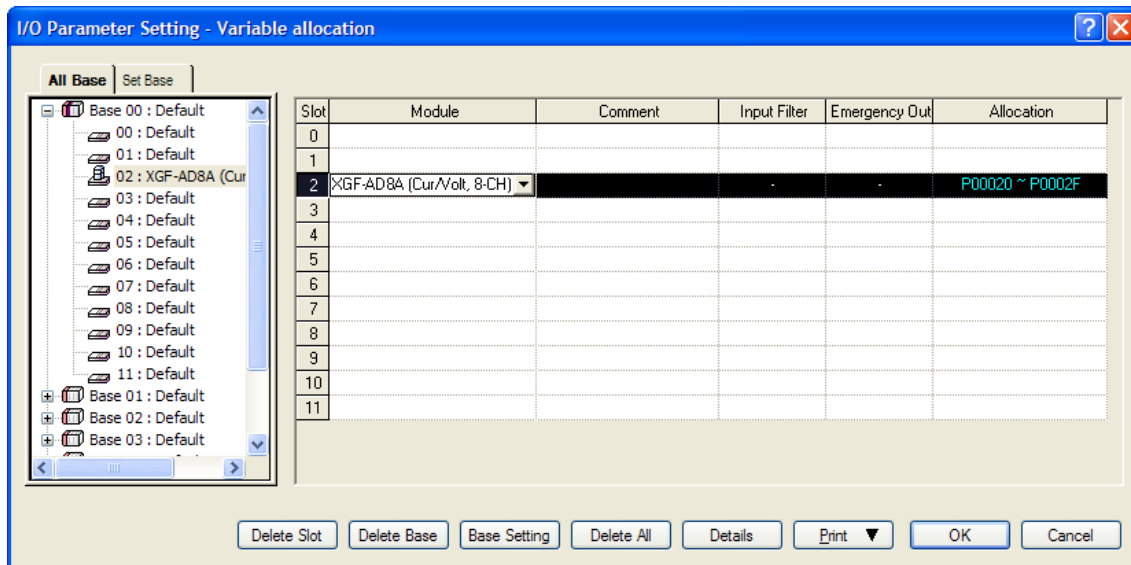

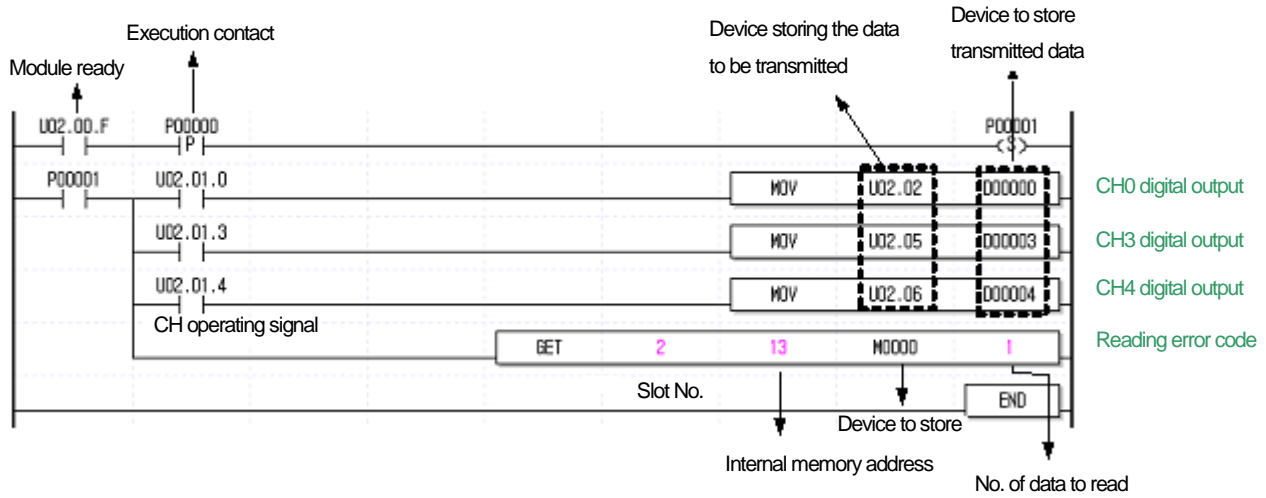

### 6.1.2 An Example of a Program That Uses the PUT/GET Command

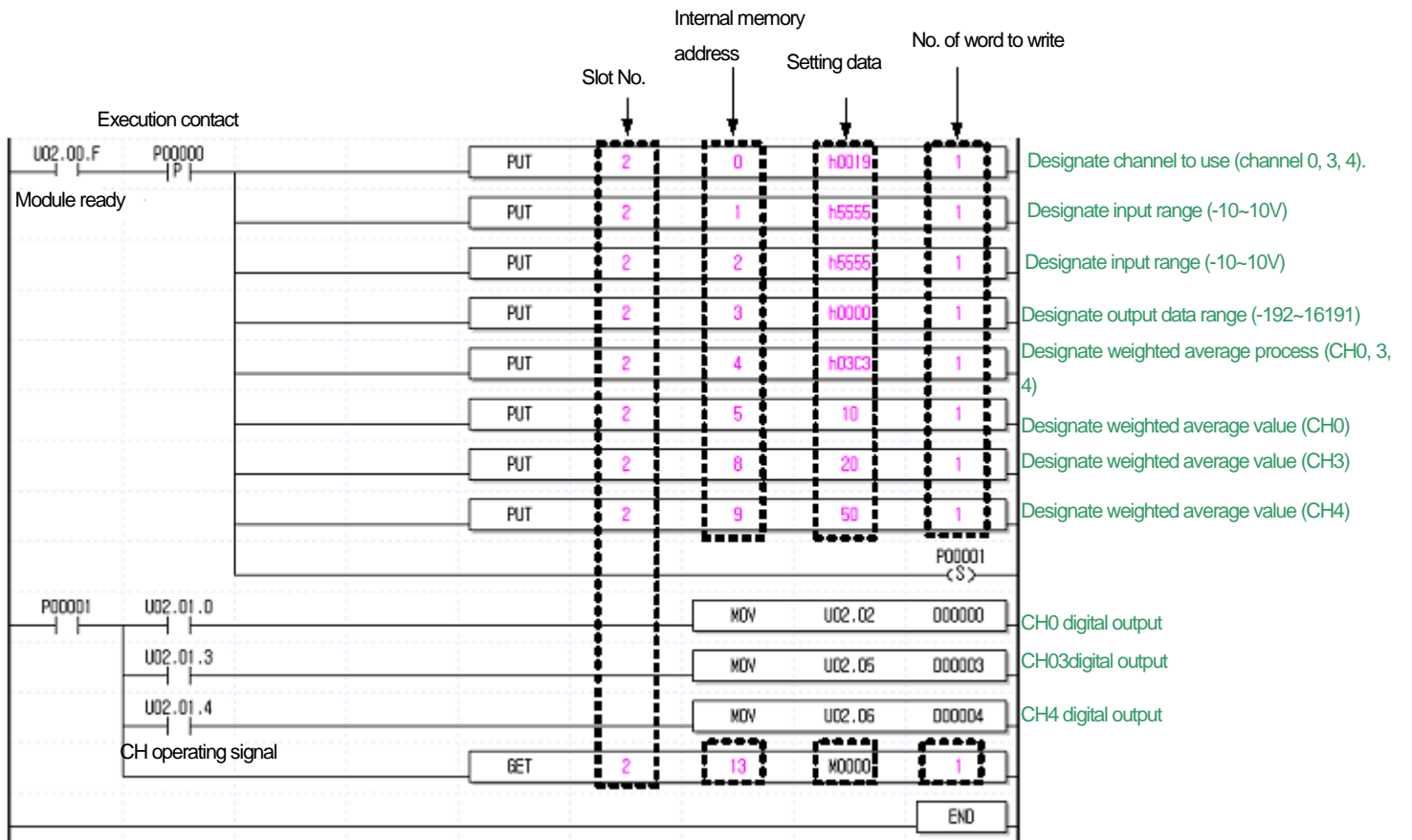

## 6.2 Application Program (XGK)

### 6.2.1 The Program Distinguishing A/D Conversion Values (I/O slot fixed point allocation: 64 points)

(1) System configuration

|              |              |              |               |              |  |
|--------------|--------------|--------------|---------------|--------------|--|
| XGP-<br>ACF2 | XGK-<br>CPUS | XGI-<br>D24A | XGF-<br>AD16A | XGQ-<br>RY2A |  |
|--------------|--------------|--------------|---------------|--------------|--|

(2) Initial setting

| No. | Item               | Initial setting                                      | Internal memory address | Values to write in internal memory |
|-----|--------------------|--|-------------------------|------------------------------------|
| 1   | Channel in use     | channel 0, channel 2, channel 4                      | 0                       | 'h0015' or '21'                    |
| 2   | Input range        | -10 ~ 10 V   | 1, 2                    | 'hFFFF' or '65535'                 |
| 3   | Output data range  | 0 ~ 16000  | 3                       | 'h0000' or '0'                     |
| 4   | Average processing | channel 2: number average<br>channel 4: time average | 4                       | 'h0120' or '288'                   |
| 5   | Average            | channel 2 number average:<br>100(times)              | 7                       | 'h0064' or '100'                   |
|     |                    | channel 4 time average: 200(ms)                      | 9                       | 'h00C8' or '200'                   |

(3) Program description

- (a) When the digital value of channel 0 is smaller than 12000, contact point 0 (P00080) of the relay output module mounted in slot 2 is On.
- (b) When the digital value of channel 2 is greater than 13600, contact point 2 (P00082) of the relay output module mounted in slot 2 is On.
- (c) When the digital value of channel 4 is greater than or equal to 12000 and smaller than or equal to 13600, contact point 4 (P00086) of the relay output module mounted in slot 2 is On.
- (d) When the digital value of channel 4 is 12800, contact point 5 (P00085) of the relay output module mounted in slot 2 is On.

(4) Program

(a) An example of the program that uses [I/O parameter] setting

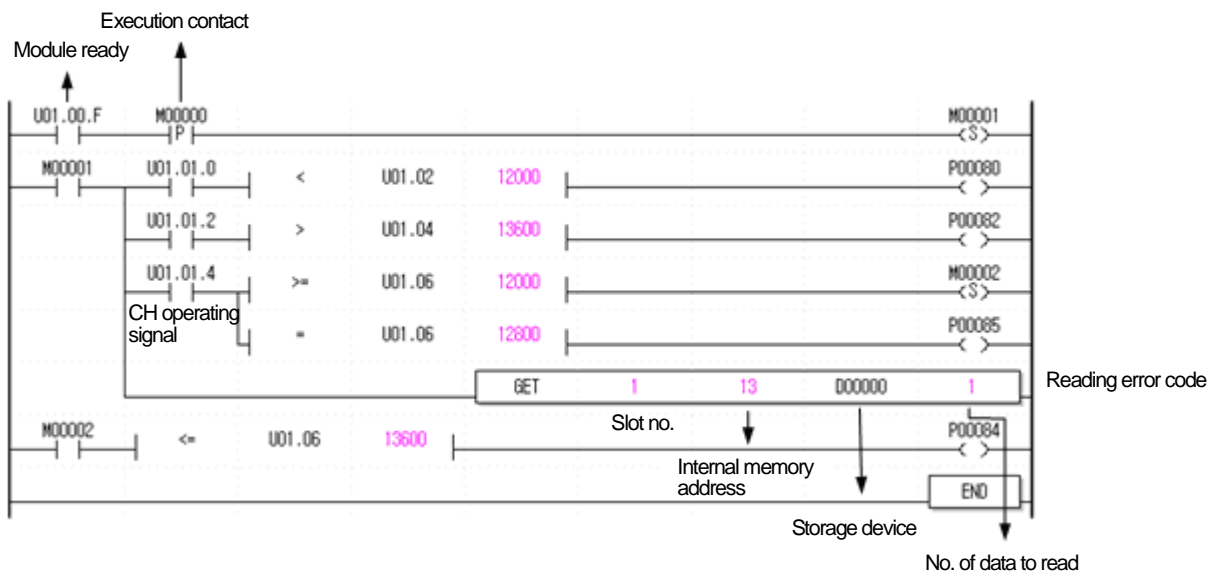
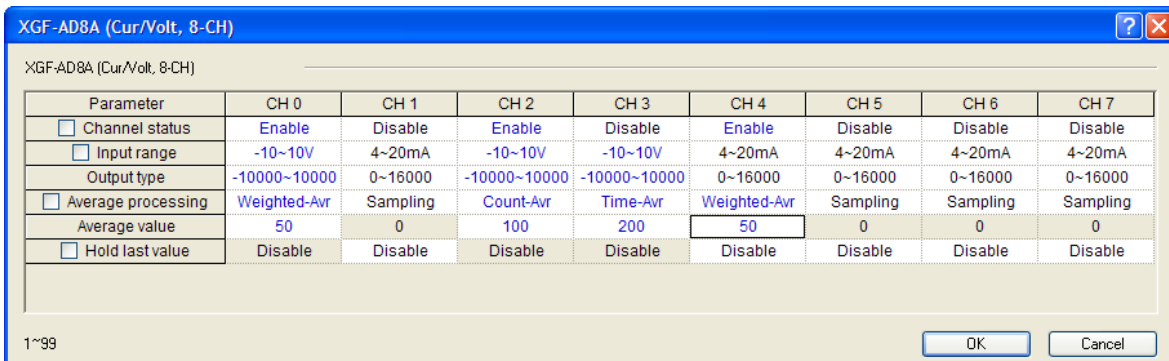
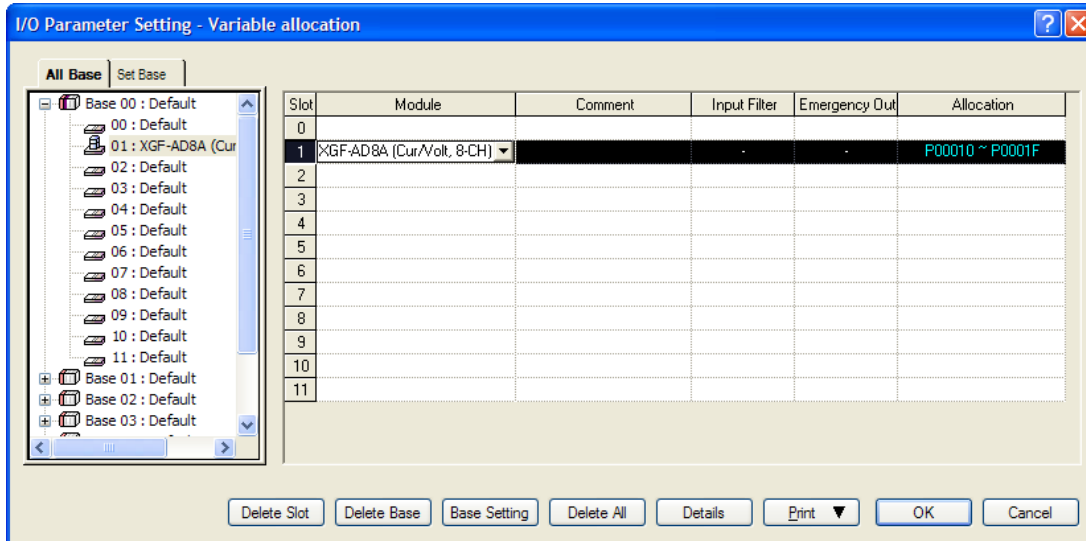

(b) An example of the program that uses PUT/GET command

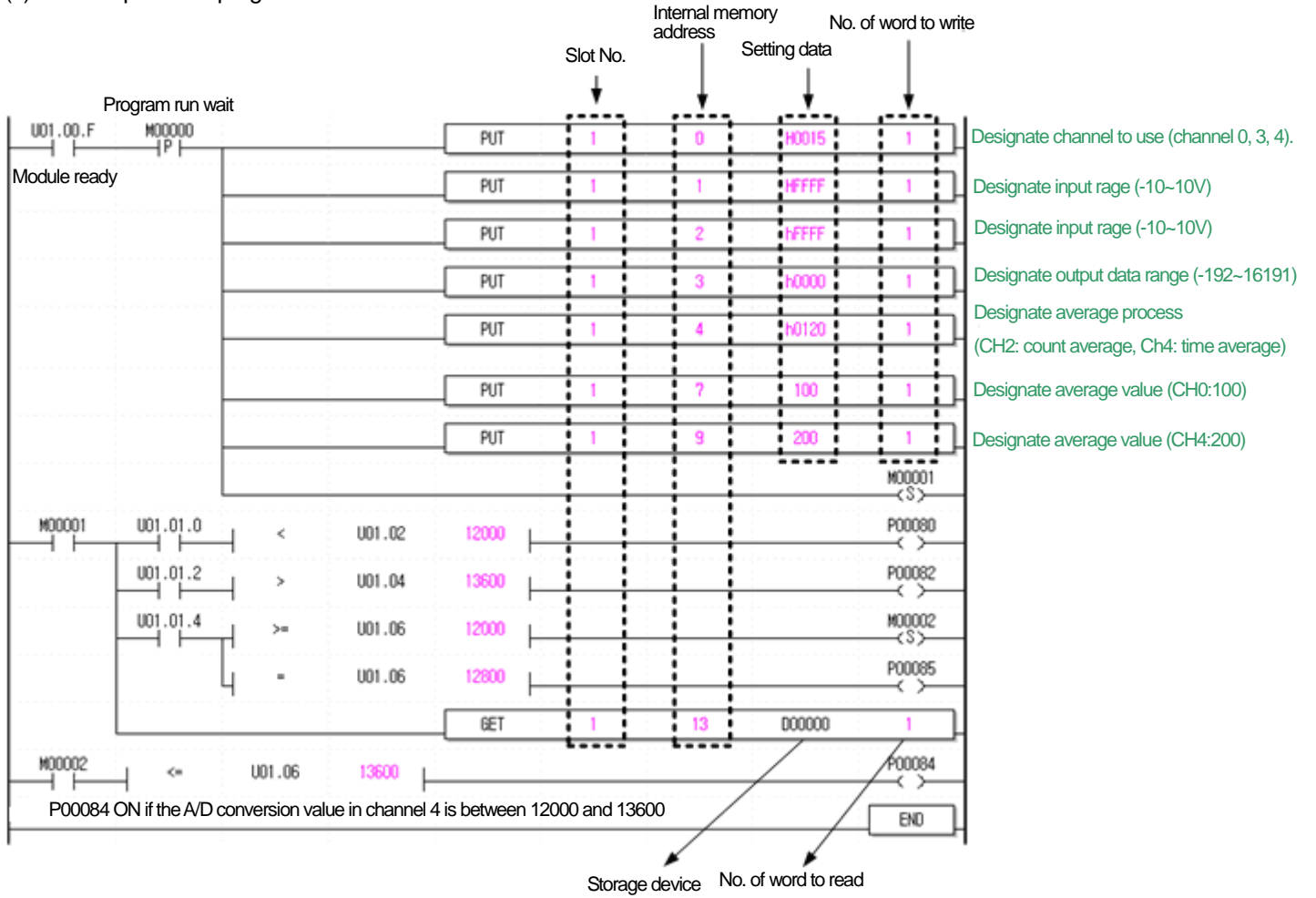

### 6.2.2 The Program That Outputs the Error Code of the Analog Input Module through BCD Display

(1) System configuration

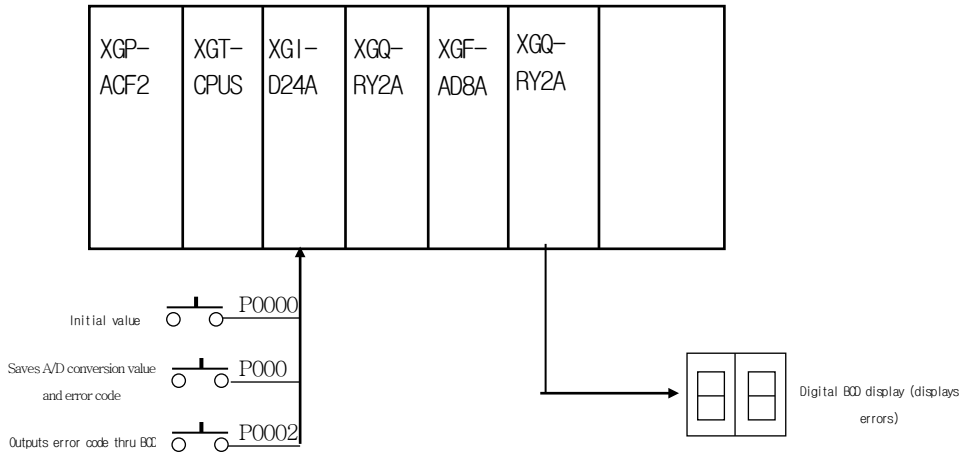

(2) Initial setting

- (a) Channel in use: channel 0
- (b) Analog input current range: DC 4 ~ 20 mA
- (c) Time average processing: 100 (ms)
- (d) Digital output data range: 0 ~ 16000

(3) Program description

- (a) Initial setting of A/D conversion when P00000 is On
- (b) The A/D conversion value and error code are respectively saved in D00000 and D00001 when P00001 is On.
- (c) The error code is displayed in the digital BCD display when P00002 is On (P00040 ~ P0004F).

(4) Program

- (a) An example of the program that uses [I/O parameter] setting

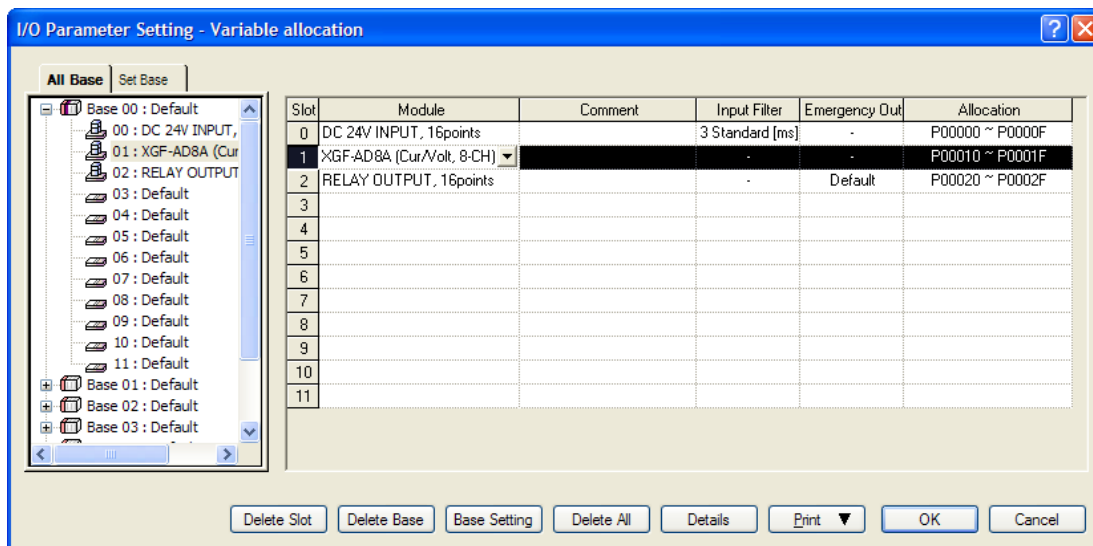

XGF-AD8A (Cur/Volt, 8-CH)

| Parameter                                   | CH 0     | CH 1     | CH 2     | CH 3     | CH 4     | CH 5     | CH 6     | CH 7     |
|---|----------|----------|----------|----------|----------|----------|----------|----------|
| <input type="checkbox"/> Channel status     | Enable   | Disable  | Disable  | Disable  | Disable  | Disable  | Disable  | Disable  |
| <input type="checkbox"/> Input range        | 4~20mA   | 4~20mA   | 4~20mA   | 4~20mA   | 4~20mA   | 4~20mA   | 4~20mA   | 4~20mA   |
| Output type                                 | 0~16000  | 0~16000  | 0~16000  | 0~16000  | 0~16000  | 0~16000  | 0~16000  | 0~16000  |
| <input type="checkbox"/> Average processing | Time-Avr | Sampling | Sampling | Sampling | Sampling | Sampling | Sampling | Sampling |
| Average value                               | 100      | 0        | 100      | 200      | 50       | 0        | 0        | 0        |
| <input type="checkbox"/> Hold last value    | Disable  | Disable  | Disable  | Disable  | Disable  | Disable  | Disable  | Disable  |

4~16000

OK Cancel

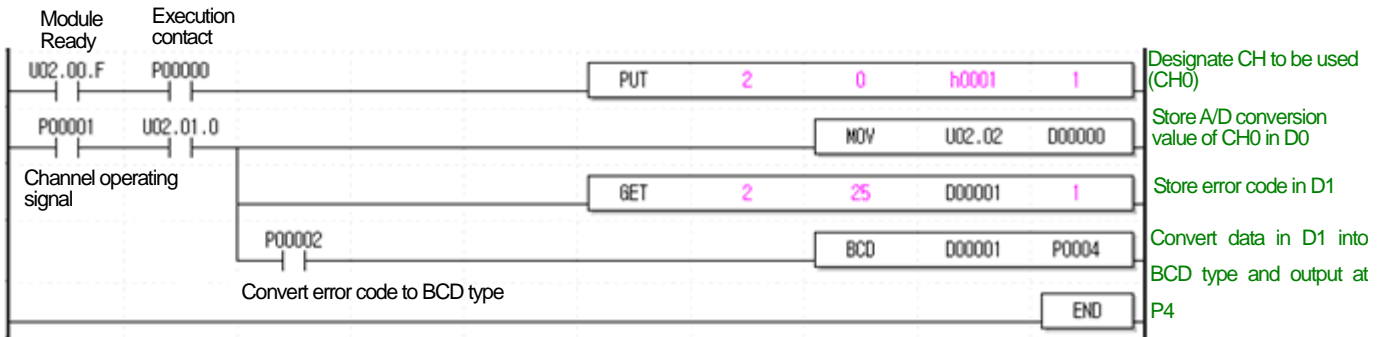

(b) An example of the program that uses PUT/GET command

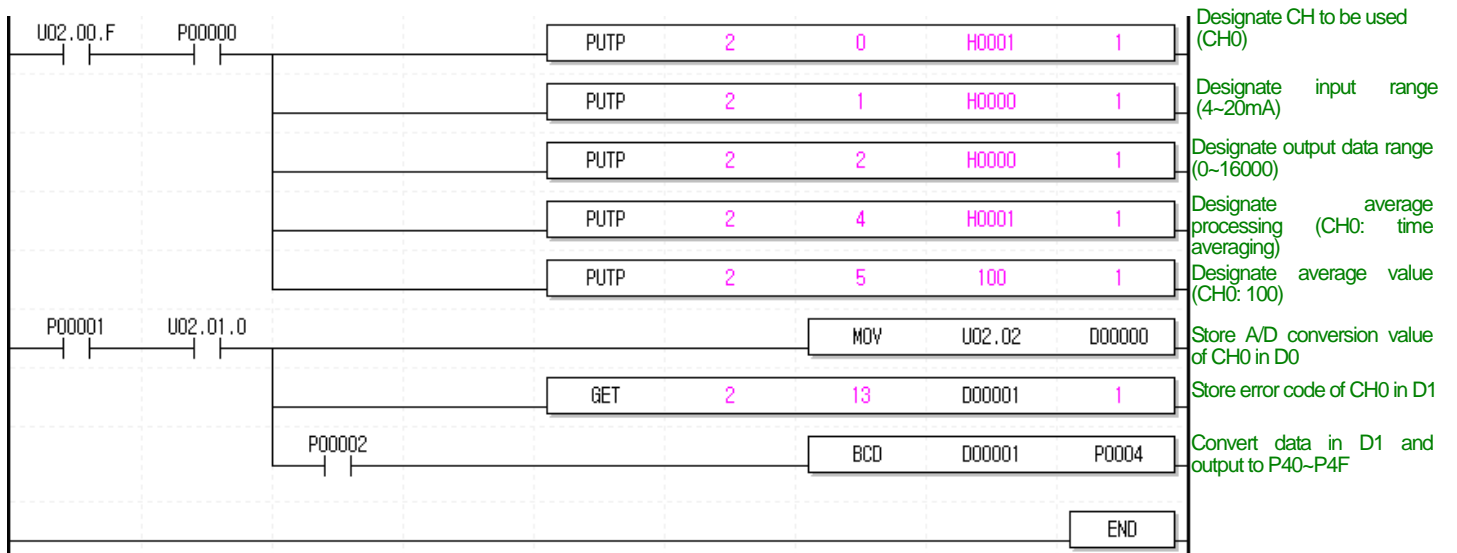



## Chapter 7 Configuration and Functions of Global Variable (For XGI/XGR)

### 7.1 Global Variables (Data Areas)

#### 7.1.1 Configuration of A/D Conversion Data Input and Output Area

Table 7.1 shows the A/D conversion data input and output Area

[Table 7. 1] A/D conversion data input and output ranges

| Global variables | Memory allocation | Description                                       | R/W   |
|------------------|-------------------|---|-------|
| _xxyy_ERR        | %UXxx.yy.0        | Module error flag                                 | Read  |
| _xxyy_RDY        | %UXxx.yy.15       | Module READY flag                                 |       |
| _xxyy_CH0_ACT    | %UXxx.yy.16       | channel 0 operating flag                          | Read  |
| _xxyy_CH1_ACT    | %UXxx.yy.17       | channel 1 operating flag                          |       |
| _xxyy_CH2_ACT    | %UXxx.yy.18       | channel 2 operating flag                          |       |
| _xxyy_CH3_ACT    | %UXxx.yy.19       | channel 3 operating flag                          |       |
| _xxyy_CH4_ACT    | %UXxx.yy.20       | channel 4 operating flag                          |       |
| _xxyy_CH5_ACT    | %UXxx.yy.21       | channel 5 operating flag                          |       |
| _xxyy_CH6_ACT    | %UXxx.yy.22       | channel 6 operating flag                          |       |
| _xxyy_CH7_ACT    | %UXxx.yy.23       | channel 7 operating flag                          |       |
| _xxyy_CH0_DATA   | %UWxx.yy.2        | channel 0 digital output value (conversion value) | Read  |
| _xxyy_CH1_DATA   | %UWxx.yy.3        | channel 1 digital output value (conversion value) |       |
| _xxyy_CH2_DATA   | %UWxx.yy.4        | channel 2 digital output value (conversion value) |       |
| _xxyy_CH3_DATA   | %UWxx.yy.5        | channel 3 digital output value (conversion value) |       |
| _xxyy_CH4_DATA   | %UWxx.yy.6        | channel 4 digital output value (conversion value) |       |
| _xxyy_CH5_DATA   | %UWxx.yy.7        | channel 5 digital output value (conversion value) |       |
| _xxyy_CH6_DATA   | %UWxx.yy.8        | channel 6 digital output value (conversion value) |       |
| _xxyy_CH7_DATA   | %UWxx.yy.9        | channel 7 digital output value (conversion value) |       |
| _xxyy_CH0_IDD    | %UXxx.yy.160      | channel 0 input disconnection detection flag      | Read  |
| _xxyy_CH1_IDD    | %UXxx.yy.161      | channel 1 input disconnection detection flag      |       |
| _xxyy_CH2_IDD    | %UXxx.yy.162      | channel 2 input disconnection detection flag      |       |
| _xxyy_CH3_IDD    | %UXxx.yy.163      | channel 3 input disconnection detection flag      |       |
| _xxyy_CH4_IDD    | %UXxx.yy.164      | channel 4 input disconnection detection flag      |       |
| _xxyy_CH5_IDD    | %UXxx.yy.165      | channel 5 input disconnection detection flag      |       |
| _xxyy_CH6_IDD    | %UXxx.yy.166      | channel 6 input disconnection detection flag      |       |
| _xxyy_CH7_IDD    | %UXxx.yy.167      | channel 7 input disconnection detection flag      |       |
| _xxyy_ERR_CLR    | %UXxx.yy.176      | Error clear request flag                          | Write |
| _xxyy_CH0_HOOR   | %UXxx.yy.320      | CH0 alarm upper limit                             | Read  |
| _xxyy_CH1_HOOR   | %UXxx.yy.321      | CH1 alarm upper limit                             |       |
| _xxyy_CH2_HOOR   | %UXxx.yy.322      | CH2 alarm upper limit                             |       |
| _xxyy_CH3_HOOR   | %UXxx.yy.323      | CH3 alarm upper limit                             |       |
| _xxyy_CH4_HOOR   | %UXxx.yy.324      | CH4 alarm upper limit                             |       |
| _xxyy_CH5_HOOR   | %UXxx.yy.325      | CH5 alarm upper limit                             |       |
| _xxyy_CH6_HOOR   | %UXxx.yy.326      | CH6 alarm upper limit                             |       |
| _xxyy_CH7_HOOR   | %UXxx.yy.327      | CH7 alarm upper limit                             |       |

|                |              |                       |      |
|----------------|--------------|-----------------------|------|
| _xxyy_CH0_LOOR | %UXxx.yy.336 | CH0 alarm lower limit | Read |
| _xxyy_CH1_LOOR | %UXxx.yy.337 | CH1 alarm lower limit |      |
| _xxyy_CH2_LOOR | %UXxx.yy.338 | CH2 alarm lower limit |      |
| _xxyy_CH3_LOOR | %UXxx.yy.339 | CH3 alarm lower limit |      |
| _xxyy_CH4_LOOR | %UXxx.yy.340 | CH4 alarm lower limit |      |
| _xxyy_CH5_LOOR | %UXxx.yy.341 | CH5 alarm lower limit |      |
| _xxyy_CH6_LOOR | %UXxx.yy.342 | CH6 alarm lower limit |      |
| _xxyy_CH7_LOOR | %UXxx.yy.343 | CH7 alarm lower limit |      |

※ Base number yy means the number of the slot where the module is mounted and xx the number of the base where the module is mounted.

### 7.1.2 How to Use Global Variables

- You can register the global variables either by automatic registration after setting I/O parameters in the project window or registering them simultaneously after setting the I/O parameters.

(1) I/O parameter registration

- You can register the module you want to use in I/O parameter.

(a) Double click on the I/O parameter in the project window.

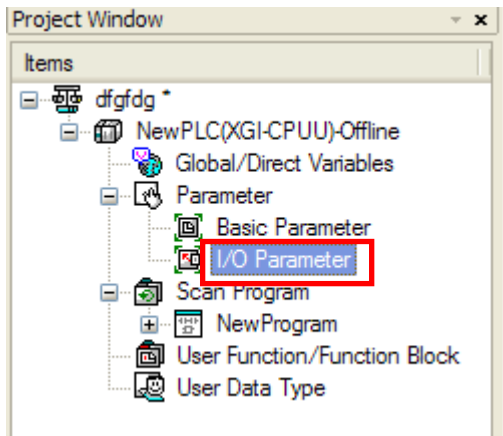

(b) Select XGF-AD8A module in the I/O parameter window.

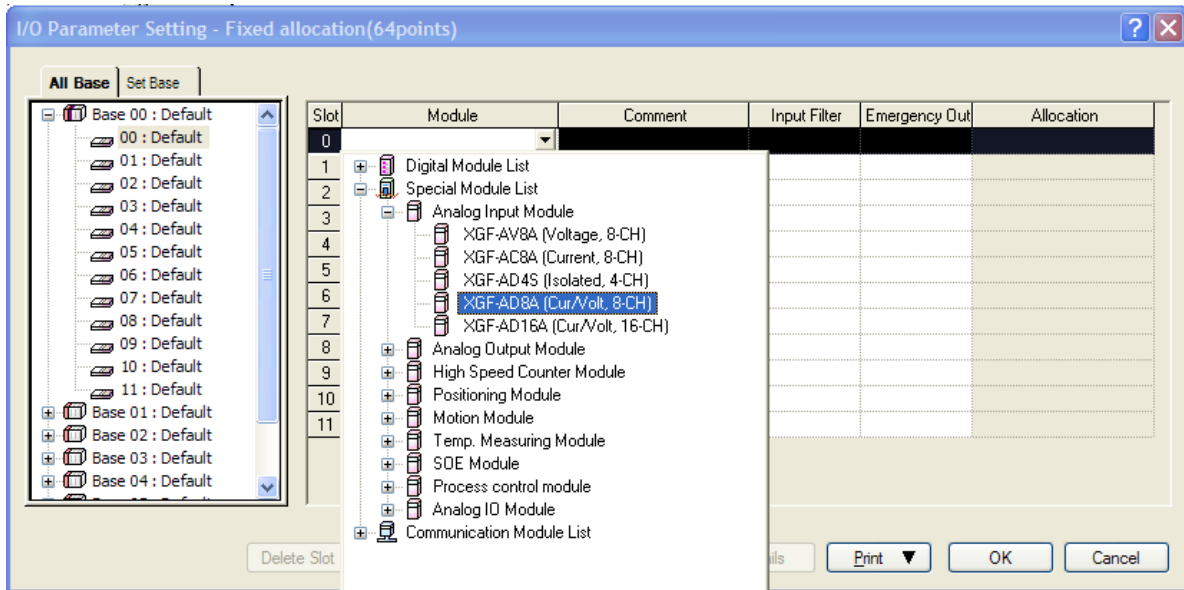

(c) Press the [Details] button, set the parameter and choose OK.

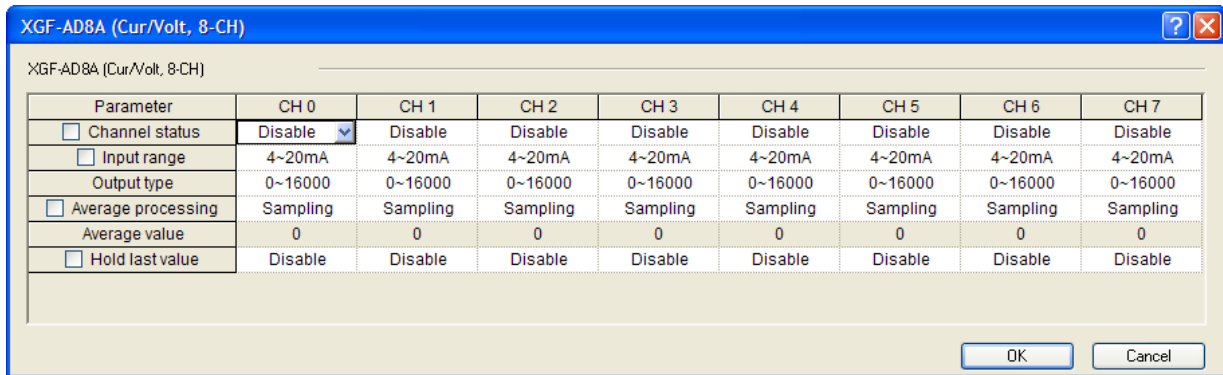

(d) Select [Y].

- The global variable of the module set in I/O parameter is automatically registered.

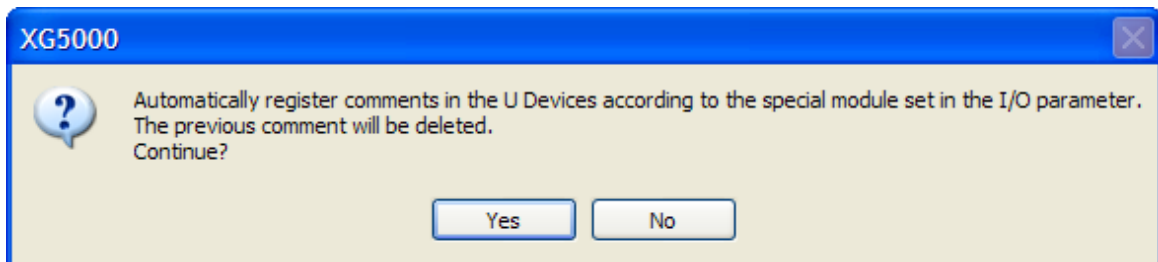

- (e) Checking the automatic registration of the global variables
  - Double-click on the global/direct variables in the project window.

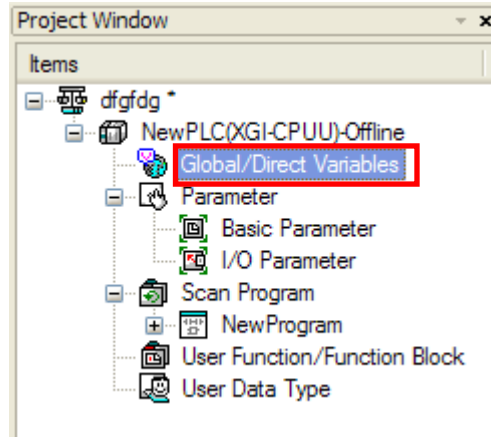

|    | Variable Kind | Variable      | Type | Address    | Initial | Retain                   | Used                     | Comment  |
|----|---------------|---------------|------|------------|---------|--------------------------|--------------------------|--|
| 37 | VAR_GLOBAL    | _0000_CH7_DAT | INT  | %UW0.0.9   |         | <input type="checkbox"/> | <input type="checkbox"/> | Analog Input Module: CH7 Output                        |
| 38 | VAR_GLOBAL    | _0000_CH7_HO  | BOOL | %UX0.0.327 |         | <input type="checkbox"/> | <input type="checkbox"/> | Analog Input Module: CH7 High Out Of Range             |
| 39 | VAR_GLOBAL    | _0000_CH7_IDD | BOOL | %UX0.0.167 |         | <input type="checkbox"/> | <input type="checkbox"/> | Analog Input Module: CH7 Input Disconnection Flag      |
| 40 | VAR_GLOBAL    | _0000_CH7_LO  | BOOL | %UX0.0.343 |         | <input type="checkbox"/> | <input type="checkbox"/> | Analog Input Module: CH0 Low Out Of Range              |
| 41 | VAR_GLOBAL    | _0000_ERR     | BOOL | %UX0.0.0   |         | <input type="checkbox"/> | <input type="checkbox"/> | Analog Input Module: Module Error                      |
| 42 | VAR_GLOBAL    | _0000_ERR_CL  | BOOL | %UX0.0.176 |         | <input type="checkbox"/> | <input type="checkbox"/> | Analog Input Module: Error Clear Request               |
| 43 | VAR_GLOBAL    | _0000_RDY     | BOOL | %UX0.0.15  |         | <input type="checkbox"/> | <input type="checkbox"/> | Analog Input Module: Module Ready                      |
| 44 | VAR_GLOBAL_C  | _F0000_AVG_SE | UINT |            | 04      | <input type="checkbox"/> | <input type="checkbox"/> | Analog Input Module: Average processing method sett    |
| 45 | VAR_GLOBAL_C  | _F0000_CH0_AV | UINT |            | 05      | <input type="checkbox"/> | <input type="checkbox"/> | Analog Input Module: CH0 average value                 |
| 46 | VAR_GLOBAL_C  | _F0000_CH1_AV | UINT |            | 06      | <input type="checkbox"/> | <input type="checkbox"/> | Analog Input Module: CH1 average value                 |
| 47 | VAR_GLOBAL_C  | _F0000_CH2_AV | UINT |            | 07      | <input type="checkbox"/> | <input type="checkbox"/> | Analog Input Module: CH2 average value                 |
| 48 | VAR_GLOBAL_C  | _F0000_CH3_AV | UINT |            | 08      | <input type="checkbox"/> | <input type="checkbox"/> | Analog Input Module: CH3 average value                 |
| 49 | VAR_GLOBAL_C  | _F0000_CH4_AV | UINT |            | 09      | <input type="checkbox"/> | <input type="checkbox"/> | Analog Input Module: CH4 average value                 |
| 50 | VAR_GLOBAL_C  | _F0000_CH5_AV | UINT |            | 10      | <input type="checkbox"/> | <input type="checkbox"/> | Analog Input Module: CH5 average value                 |
| 51 | VAR_GLOBAL_C  | _F0000_CH6_AV | UINT |            | 11      | <input type="checkbox"/> | <input type="checkbox"/> | Analog Input Module: CH6 average value                 |
| 52 | VAR_GLOBAL_C  | _F0000_CH7_AV | UINT |            | 12      | <input type="checkbox"/> | <input type="checkbox"/> | Analog Input Module: CH7 average value                 |
| 53 | VAR_GLOBAL_C  | _F0000_CH_EN  | UINT |            | 00      | <input type="checkbox"/> | <input type="checkbox"/> | Analog Input Module: Channel enable/disable setting    |
| 54 | VAR_GLOBAL_C  | _F0000_DATA_T | UINT |            | 03      | <input type="checkbox"/> | <input type="checkbox"/> | Analog Input Module: Output data type setting          |
| 55 | VAR_GLOBAL_C  | _F0000_ERR_C  | UINT |            | 13      | <input type="checkbox"/> | <input type="checkbox"/> | Analog Input Module: Error codes                       |
| 56 | VAR_GLOBAL_C  | _F0000_HOLD_L | UINT |            | 14      | <input type="checkbox"/> | <input type="checkbox"/> | Analog Input Module: Hold last value setting           |
| 57 | VAR_GLOBAL_C  | _F0000_IN_RAN | UINT |            | 01      | <input type="checkbox"/> | <input type="checkbox"/> | Analog Input Module: Input current /voltage ranges set |
| 58 | VAR_GLOBAL_C  | _F0000_IN_RAN | UINT |            | 02      | <input type="checkbox"/> | <input type="checkbox"/> | Analog Input Module: Input current /voltage ranges set |

(2) Global variables registration

- You can register the global variables of the module set in I/O parameter.

(a) Double click on the global/direct variables in the project window.

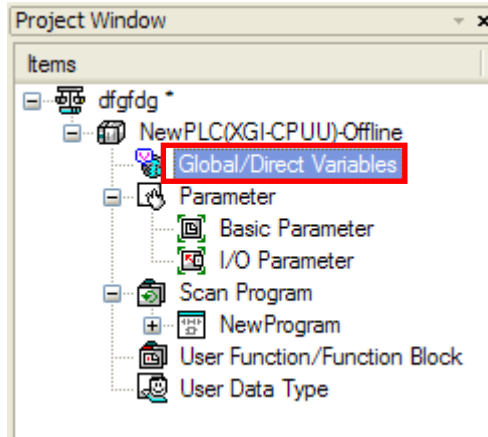

(b) Select [Register Special/Communication Module Variables] in [Edit] of the main menu.

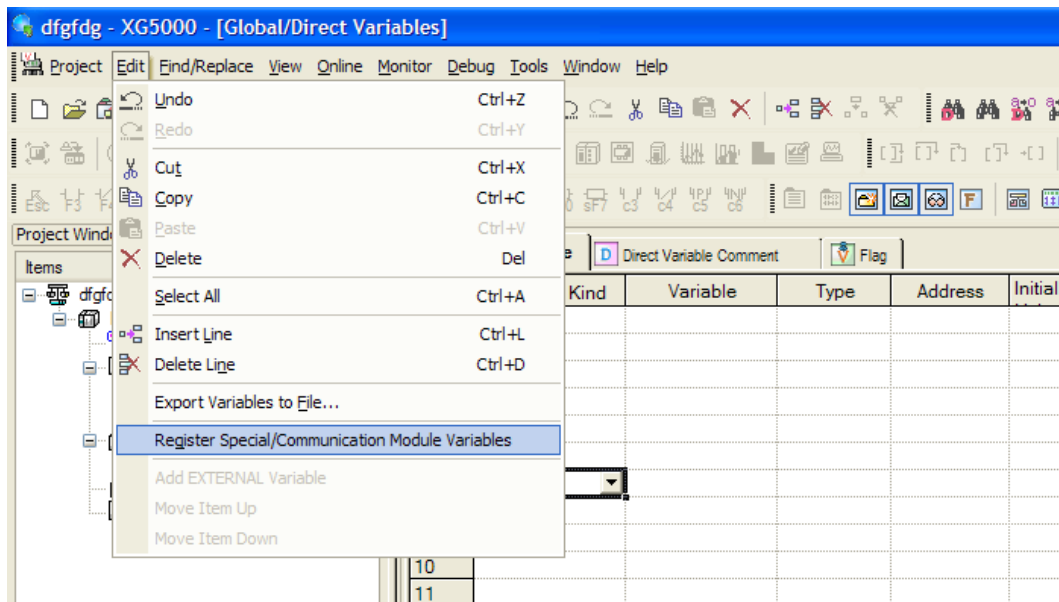

| Variable Kind | Variable                  | Type | Address    | Initial | Retain                   | Used                     | Comment   |
|---------------|---------------------------|------|------------|---------|--------------------------|--------------------------|---|
| 37            | VAR_GLOBAL _0000_CH7_DAT  | INT  | %UW0.0.9   |         | <input type="checkbox"/> | <input type="checkbox"/> | Analog Input Module: CH7 Output                     |
| 38            | VAR_GLOBAL _0000_CH7_HO   | BOOL | %UX0.0.327 |         | <input type="checkbox"/> | <input type="checkbox"/> | Analog Input Module: CH7 High Out Of Range          |
| 39            | VAR_GLOBAL _0000_CH7_IDD  | BOOL | %UX0.0.167 |         | <input type="checkbox"/> | <input type="checkbox"/> | Analog Input Module: CH7 Input Disconnection Flag   |
| 40            | VAR_GLOBAL _0000_CH7_LO   | BOOL | %UX0.0.343 |         | <input type="checkbox"/> | <input type="checkbox"/> | Analog Input Module: CH0 Low Out Of Range           |
| 41            | VAR_GLOBAL _0000_ERR      | BOOL | %UX0.0.0   |         | <input type="checkbox"/> | <input type="checkbox"/> | Analog Input Module: Module Error                   |
| 42            | VAR_GLOBAL _0000_ERR_CL   | BOOL | %UX0.0.176 |         | <input type="checkbox"/> | <input type="checkbox"/> | Analog Input Module: Error Clear Request            |
| 43            | VAR_GLOBAL _0000_RDY      | BOOL | %UX0.0.15  |         | <input type="checkbox"/> | <input type="checkbox"/> | Analog Input Module: Module Ready                   |
| 44            | VAR_GLOBAL_C_F0000_AVG_SE | UINT |            | 04      | <input type="checkbox"/> | <input type="checkbox"/> | Analog Input Module: Average processing method sett |
| 45            | VAR_GLOBAL_C_F0000_CH0_AV | UINT |            | 05      | <input type="checkbox"/> | <input type="checkbox"/> | Analog Input Module: CH0 average value              |
| 46            | VAR_GLOBAL_C_F0000_CH1_AV | UINT |            | 06      | <input type="checkbox"/> | <input type="checkbox"/> | Analog Input Module: CH1 average value              |
| 47            | VAR_GLOBAL_C_F0000_CH2_AV | UINT |            | 07      | <input type="checkbox"/> | <input type="checkbox"/> | Analog Input Module: CH2 average value              |
| 48            | VAR_GLOBAL_C_F0000_CH3_AV | UINT |            | 08      | <input type="checkbox"/> | <input type="checkbox"/> | Analog Input Module: CH3 average value              |
| 49            | VAR_GLOBAL_C_F0000_CH4_AV | UINT |            | 09      | <input type="checkbox"/> | <input type="checkbox"/> | Analog Input Module: CH4 average value              |
| 50            | VAR_GLOBAL_C_F0000_CH5_AV | UINT |            | 10      | <input type="checkbox"/> | <input type="checkbox"/> | Analog Input Module: CH5 average value              |
| 51            | VAR_GLOBAL_C_F0000_CH6_AV | UINT |            | 11      | <input type="checkbox"/> | <input type="checkbox"/> | Analog Input Module: CH6 average value              |
| 52            | VAR_GLOBAL_C_F0000_CH7_AV | UINT |            | 12      | <input type="checkbox"/> | <input type="checkbox"/> | Analog Input Module: CH7 average value              |
| 53            | VAR_GLOBAL_C_F0000_CH_EN  | UINT |            | 00      | <input type="checkbox"/> | <input type="checkbox"/> | Analog Input Module: Channel enable/disable setting |
| 54            | VAR_GLOBAL_C_F0000_DATA_T | UINT |            | 03      | <input type="checkbox"/> | <input type="checkbox"/> | Analog Input Module: Output data type setting       |

(3) Local variables registration

- You can register the registered global variables that you want to use as the local variables.

(a) Double-click on the local variables of the program where you want to use the global variables in the scan program below.

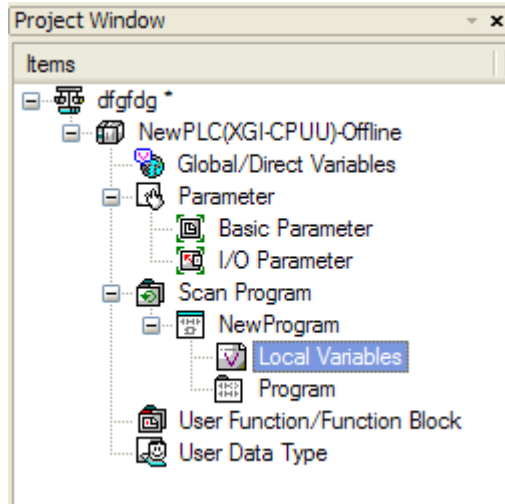

(b) Press the right button of the mouse in the right local variable window and select “Add external variable.”

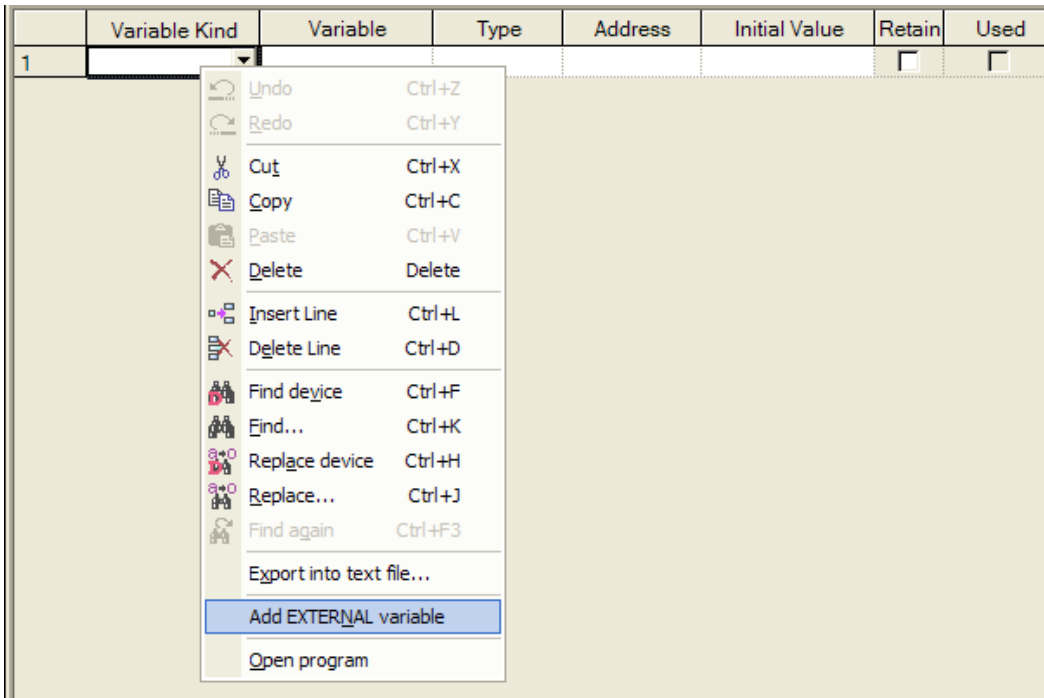

(c) Select “all” or “base slot” in View global variables for the local variables that you want to add in the “External variable add window” below.

- View all

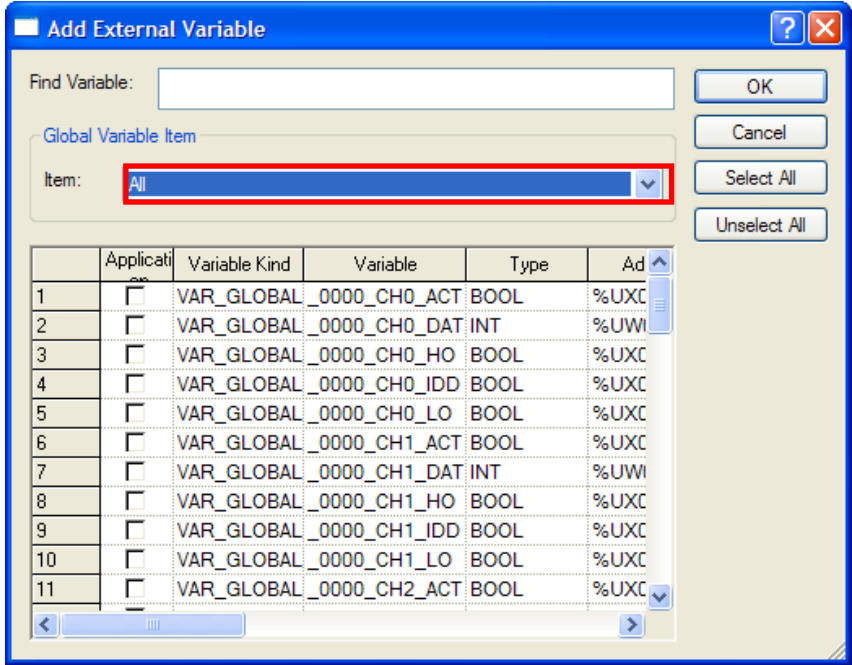

- View each base slot

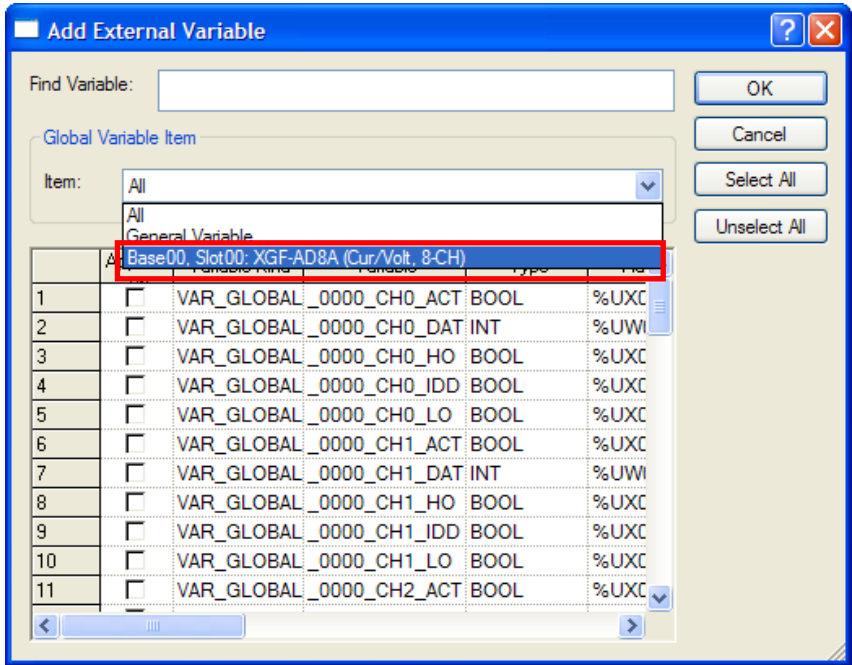

(d) The following is an example that the digital input value (\_0000\_CH0\_DATA) of “base00 slot00” in View global variables.

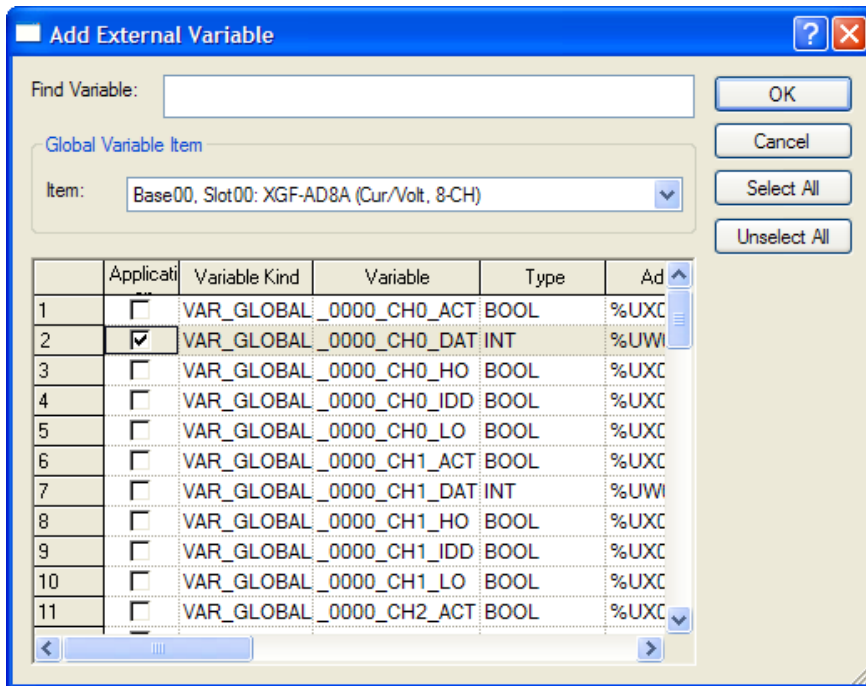

(4) How to use local variables in the program

- This section describes how to use the added global variables in the local program.
- The following is an example in which the conversion value of channel 0 of the A/D conversion module is brought to %MW0.

(a) Double click on the variable before IN in the area where the A/D conversion data is read as %MW0 by using the MOVE function below and invoke the variable selection window.

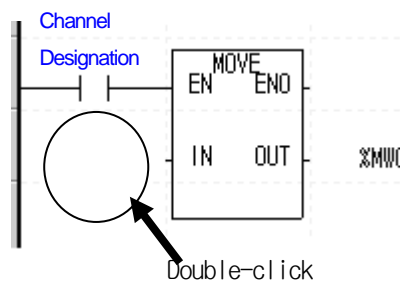

- (b) Choose the global variable as the variable type in the variable selection window and then the corresponding base in the View global variable item (base 0, slot 0).

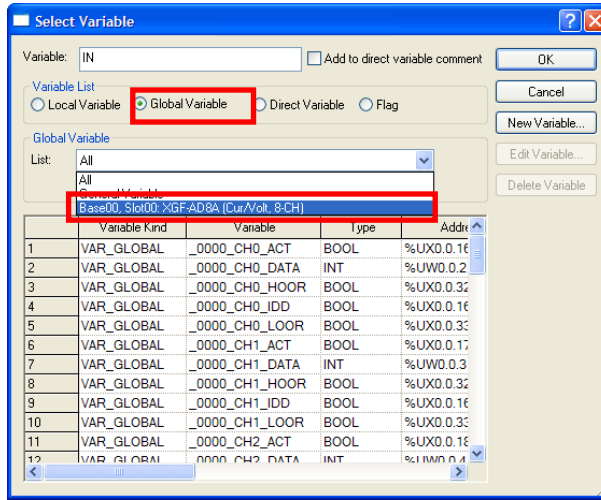

- (c) Double-click on \_0000\_CH0\_DATA that corresponds to the A/D conversion data of channel 0 and click on [OK].

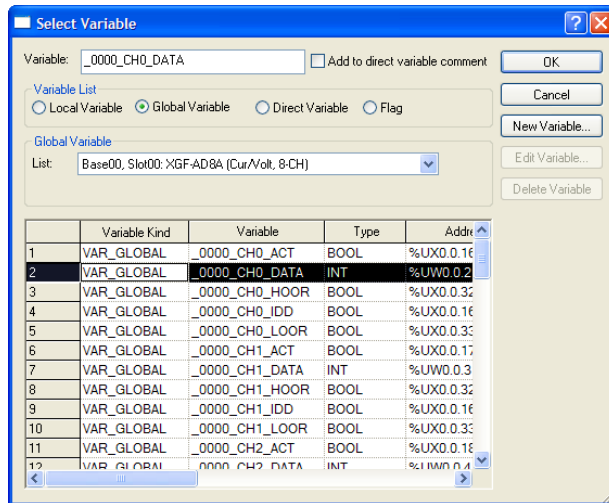

- (d) The following is the result of adding the global variable corresponding to the A/D conversion data of channel 0.

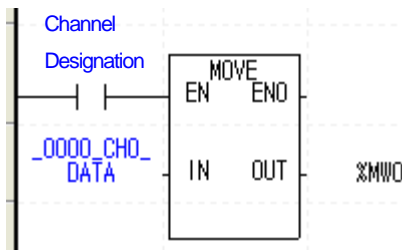

## 7.2 PUT/GET Function Block Area (Parameter Area)

### 7.2.1 PUT/GET Function Block Area (Parameter Area)

Table 7.2 shows the operating parameter setting area of the analog input module.

[Table 7. 2] Operating parameter setting ranges

| Global variables   | Designation  | Command |
|--|--|---------|
| _Fxyy_AVG_SEL1<br>_Fxyy_CH_EN  | Average processing method<br>Channel to use  | PUT     |
| _Fxyy_CH0_AVG_VAL<br>_Fxyy_CH1_AVG_VAL<br>_Fxyy_CH2_AVG_VAL<br>_Fxyy_CH3_AVG_VAL<br>_Fxyy_CH4_AVG_VAL<br>_Fxyy_CH5_AVG_VAL<br>_Fxyy_CH6_AVG_VAL<br>_Fxyy_CH7_AVG_VAL | channel 0 average<br>channel 1 average<br>channel 2 average<br>channel 3 average<br>channel 4 average<br>channel 5 average<br>channel 6 average<br>channel 7 average | PUT     |
| _Fxyy_DATA_TYPE<br>_Fxyy_IN_RANGE1<br>_Fxyy_IN_RANGE2  | Output data type<br>Input current/voltage range 1<br>Input current/voltage range 2   | PUT     |
| _Fxyy_ERR_CODE   | Error code   | GET     |
| _Fxyy_HOLD_LV  | Hold last value  | PUT     |

※ In device allocation, xx and yy respectively mean the numbers of the base and slot where the module is mounted.

7.2.2 PUT/GET Commands

(1) PUT Command

|                              |
|------------------------------|
| PUT                          |
| Write data in special module |

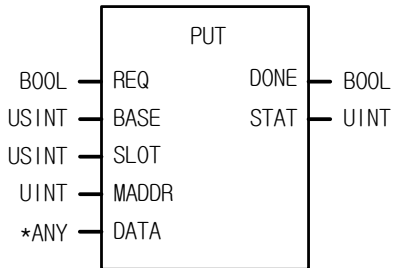
| Function block  | Description   |
|---|---|
|  <pre> graph LR     subgraph PUT         REQ[REQ] --- BASE[BASE] --- SLOT[SLOT] --- MADDR[MADDR] --- DATA[DATA]         BASE --- SLOT --- MADDR --- DATA         SLOT --- MADDR --- DATA         MADDR --- DATA     end     REQ --- DONE[DONE]     STAT[STAT] --- STAT     </pre> | <p><b>Input</b></p> <p>REQ : performs function when 1</p> <p>BASE : designates base location</p> <p>SLOT : designates slot location</p> <p>MADDR : module address</p> <p>DATA : data to save in module</p> <p><b>Output</b></p> <p>DONE : outputs 1 when normally functioning</p> <p>STAT : error information</p> |

\*ANY: WORD, DWORD, INT, USINT, DINT, UDINT types are available of ANY types.

■ Functions

Writes data from the designated special module.

| Function block | ANY type | Function   |
|----------------|----------|--|
| PUT_WORD       | WORD     | Saves WORD data in the designated module address (MADDR).  |
| PUT_DWORD      | DWORD    | Saves DWORD data in the designated module address (MADDR). |
| PUT_INT        | INT      | Saves INT data in the designated module address (MADDR).   |
| PUT_UINT       | UINT     | Saves UINT data in the designated module address (MADDR).  |
| PUT_DINT       | DINT     | Saves DINT data in the designated module address (MADDR).  |
| PUT_UDINT      | UDINT    | Saves UDINT data in the designated module address (MADDR). |

(2) GET command

|                             |
|-----------------------------|
| <b>GET</b>                  |
| Read data in special module |

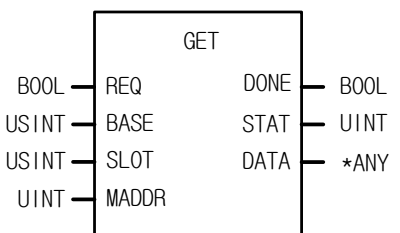
| Function block   | Description  |
|--|--|
|  | <p><b>Input</b></p> <p>REQ : performs function when 1<br/>           BASE : designates base location<br/>           SLOT : designates slot location<br/>           MADDR : module address<br/>                     512(0x200) ~ 1023(0x3FF)</p> <p><b>Output</b></p> <p>DONE : outputs 1 when normally functioning<br/>           STAT : error information<br/>           DATA : data read from module</p> |

\*ANY: WORD, DWORD, INT, USINT, DINT, UDINT types are available of ANY types.

■ **Functions**

Reads data from the designated special module.

| Function block | ANY type | Function   |
|----------------|----------|--|
| GET_WORD       | WORD     | Reads WORD data from the designated module address (MADDR).  |
| GET_DWORD      | DWORD    | Reads DWORD data from the designated module address (MADDR). |
| GET_INT        | INT      | Reads INT data from the designated module address (MADDR).   |
| GET_UINT       | UINT     | Reads UINT data from the designated module address (MADDR).  |
| GET_DINT       | DINT     | Reads DINT data from the designated module address (MADDR).  |
| GET_UDINT      | UDINT    | Reads UDINT data from the designated module address (MADDR). |

7.2.3 Examples of Use of PUT/GET Commands

(1) Designation of channel to use

- (a) You can set Allow/block of A/D conversion for each channel.
- (b) You can shorten the conversion cycle for each channel by blocking conversion of the unused channel.
- (c) When no channel is designated for use, all channels are blocked from use.
- (d) Allow/block of A/D conversion is as follows.

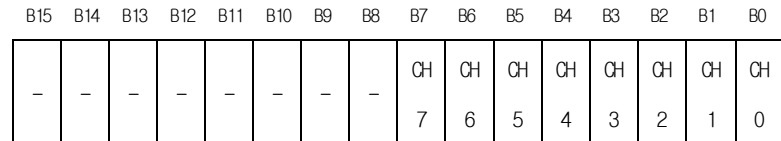

| Bit | Description |
|-----|-------------|
| 0   | Stop        |
| 1   | Operating   |

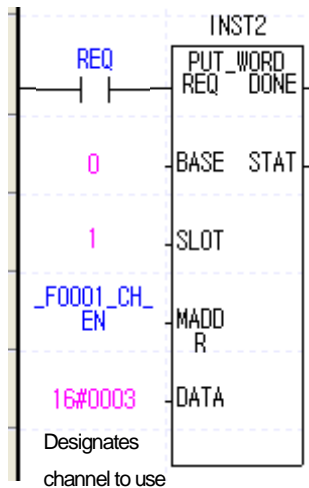
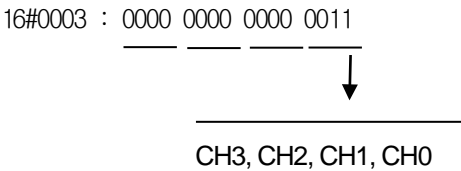

- (e) The values set between B2 ~ B15 will be ignored.
- (f) The illustration on the right side is an example of designating channels 0~1 as the use channel of the analog input module.

(2) Designation of Input Voltage/Current Ranges

- (a) You can designate the analog input voltage/current ranges for each channel.
- (b) When no analog input range is designated, all channels are set as 1 ~ 5 V (4 ~ 20 mA).
- (c) The setting of analog input voltage/current ranges is as follows.
  - The following example is when channels 0~1 are 1~5V and channels 2~3 are 0~10V.

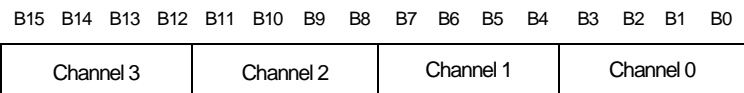

| BIT  | Ranges       |
|------|--------------|
| 0000 | 4 mA ~ 20 mA |
| 0001 | 0 mA ~ 20 mA |
| 0010 | 1 V ~ 5 V    |
| 0011 | 0 V ~ 5 V    |
| 0100 | 0 V ~ 10 V   |
| 0101 | -10 V ~ 10 V |

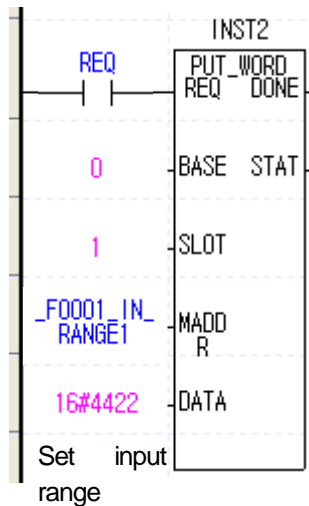
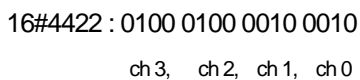

(3) Output data range setting

- (a) You can designate the digital output data ranges for analog input for each channel.
- (b) When no analog input range is designated, all channels are set as 0 ~ 16000.
- (c) The setting of digital output data ranges is as follows.

|         |         |         |         |         |         |         |         |         |         |         |         |         |         |         |         |
|---------|---------|---------|---------|---------|---------|---------|---------|---------|---------|---------|---------|---------|---------|---------|---------|
| B15     | B14     | B13     | B12     | B11     | B10     | B9      | B8      | B7      | B6      | B5      | B4      | B3      | B2      | B1      | B0      |
| Channel | Channel | Channel | Channel | Channel | Channel | Channel | Channel | Channel | Channel | Channel | Channel | Channel | Channel | Channel | Channel |
| 7       | 6       | 5       | 4       | 3       | 2       | 1       | 0       |         |         |         |         |         |         |         |         |

| BIT | Ranges        |
|-----|---------------|
| 00  | 0 ~ 16000     |
| 01  | -8000~8000    |
| 10  | Precise Value |
| 11  | 0 ~ 10000     |

16#2012 : 00 10 00 00 00 01 00 10  
 ch 7, ch 6, ch 5, ch 4 ch 3, ch 2, ch 1, ch 0

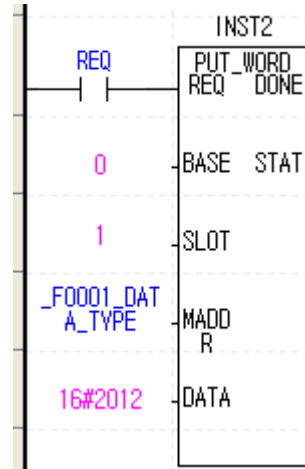

The precise value has the following digital output ranges for the analog input range.

1) Current

|                       |                  |                  |
|-----------------------|------------------|------------------|
| <b>Analog input</b>   | <b>4 ~ 20 mA</b> | <b>0 ~ 20 mA</b> |
| <b>Digital output</b> |                  |                  |
| Precise Value         | 4000 ~ 20000     | 0 ~ 20000        |

2) Voltage

|                       |                   |                 |                |                |
|-----------------------|-------------------|-----------------|----------------|----------------|
| <b>Analog input</b>   | <b>-10 ~ 10 V</b> | <b>0 ~ 10 V</b> | <b>0 ~ 5 V</b> | <b>1 ~ 5 V</b> |
| <b>Digital output</b> |                   |                 |                |                |
| Precise Value         | -10000 ~ 10000    | 0 ~ 10000       | 0 ~ 5000       | 1000 ~ 5000    |

(4) Average processing setting

- (a) You can set Allow/block of average processing for each channel.
- (b) When no average processing is designated, all channels conduct sampling processing.
- (c) The designation of average processing is as follows.
- (d) The following illustration is an example when time average is used for channel 1.

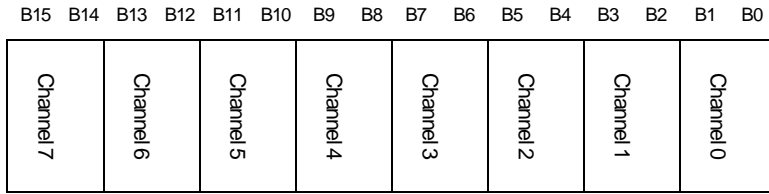

| BIT | Description         |
|-----|---------------------|
| 00  | Sampling processing |
| 01  | Time average        |
| 10  | Number average      |
| 11  | Weighted average    |

16#0010 : 00 00 00 00 01 00 00  
 ch 7, ch 6, ch 5, ch 4 ch 3, ch 2, ch 1, ch 0

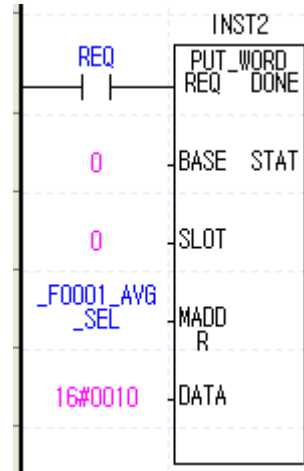

(5) Designation of average values

- (a) The initial value of the average designation range is 0.
- (b) The setting range of the average designation is as follows.

| Average          | Range             |
|------------------|-------------------|
| Time average     | 16 ~ 5000(ms)     |
| Count average    | 2 ~ 64000 (times) |
| Weighted average | 1 ~ 99(%)         |

- (c) When a value beyond the range is designated, the error number is displayed in the error code display (\_F0001\_ERR\_CODE). Then the A/D conversion value remains the previous data. (# refers to the channel where the error occurred)
- (d) The setting of the average is as follows.

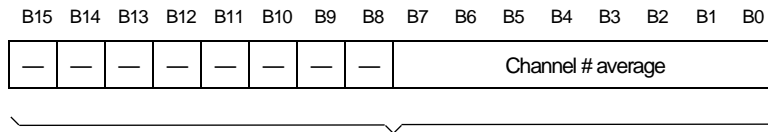

Time average setting range is 16 ~ 16000  
 Count average setting range is 2 ~ 64000  
 Weighted average setting range is 1 ~ 99

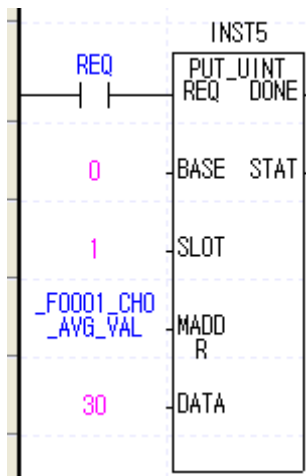

※ In device allocation, xx and yy respectively mean the numbers of the base and slot where the module is mounted.

| Address    | Description  |
|------------|--|
| Address 5  | Designates the average processing value of channel 0 |
| Address 6  | Designates the average processing value of channel 1 |
| Address 7  | Designates the average processing value of channel 2 |
| Address 8  | Designates the average processing value of channel 3 |
| Address 9  | Designates the average processing value of channel 4 |
| Address 10 | Designates the average processing value of channel 5 |
| Address 11 | Designates the average processing value of channel 6 |
| Address 12 | Designates the average processing value of channel 7 |

**Note**

When you designate the time/number average processing values, set average processing as 'Allow' in advance. As for average processing, choose between time average and number average.

(9) Error code

- (a) Saves the error code detected in the analog input module.
- (b) The types and descriptions of errors are as follows.
- (c) The following illustration is an example of reading the error code.

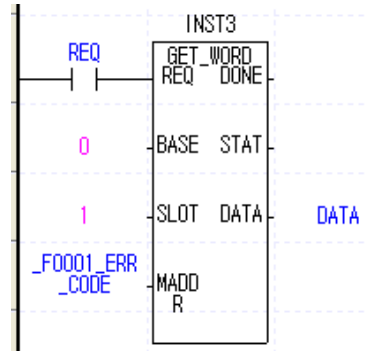
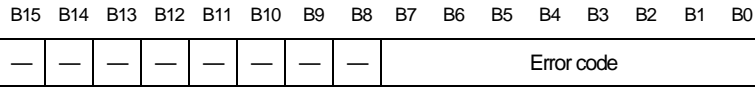

| Error code (Decimal) | Description of the error   | Note                             |
|----------------------|--|----------------------------------|
| 0                    | Normal operation   | RUN LED on                       |
| 11                   | module error (ASIC RAM or Register Error)  | RUN LED flashes every 0.2 second |
| 20                   | module error (A/D Conversion Error)  |                                  |
| 40##                 | module error (The offset value of 4 ~ 20 mA is larger than or equal to the gain value)   | RUN LED flashes every second     |
| 41##                 | module error (The offset value of 0 ~ 20 mA is larger than or equal to the gain value.)  |                                  |
| 42##                 | module error (The offset value of 1 ~ 5 V is larger than or equal to the gain value.)    |                                  |
| 43##                 | module error (The offset value of 0 ~ 5 V is larger than or equal to the gain value.)    |                                  |
| 44##                 | module error (The offset value of 0 ~ 10 V is larger than or equal to the gain value.)   |                                  |
| 45##                 | module error (The offset value of -10 ~ 10 V is larger than or equal to the gain value.) |                                  |
| 50##                 | Beyond the time average setting range  |                                  |
| 60##                 | Beyond the number average setting range  |                                  |
| 70##                 | Beyond the weighted average setting range  |                                  |

- ※ # of the error code means the channel where the error occurred.
- ※ For details of the error codes, see 9.1.

- (d) If there are two or more errors, the module saves the error code that happened first and does not save the following error codes.
- (e) If there is an error, you should use the error clear request flag (see 5.2.5) or turn the power supply Off → On after the error is corrected so that the LED stops flashing and the error code is deleted.



Chapter 8 Programming (For XGI/XGR)

8.1 The Basic Program

- This chapter provides information on how to set the operating conditions for the internal memory of the analog input module.
- The analog input module is mounted in slot 2.
- The input and output occupancy point of the analog input module is 16 points (variable).
- The initial setting condition is one time entry. The setting of the initial value is saved in the internal memory of the analog input module.

8.1.1 An Example of a Program That Uses [I/O Parameter]

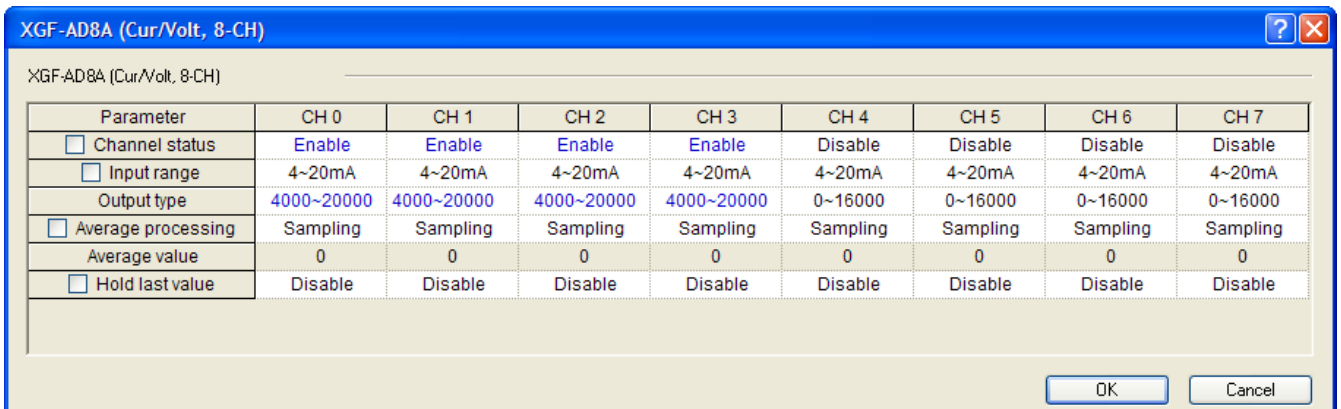
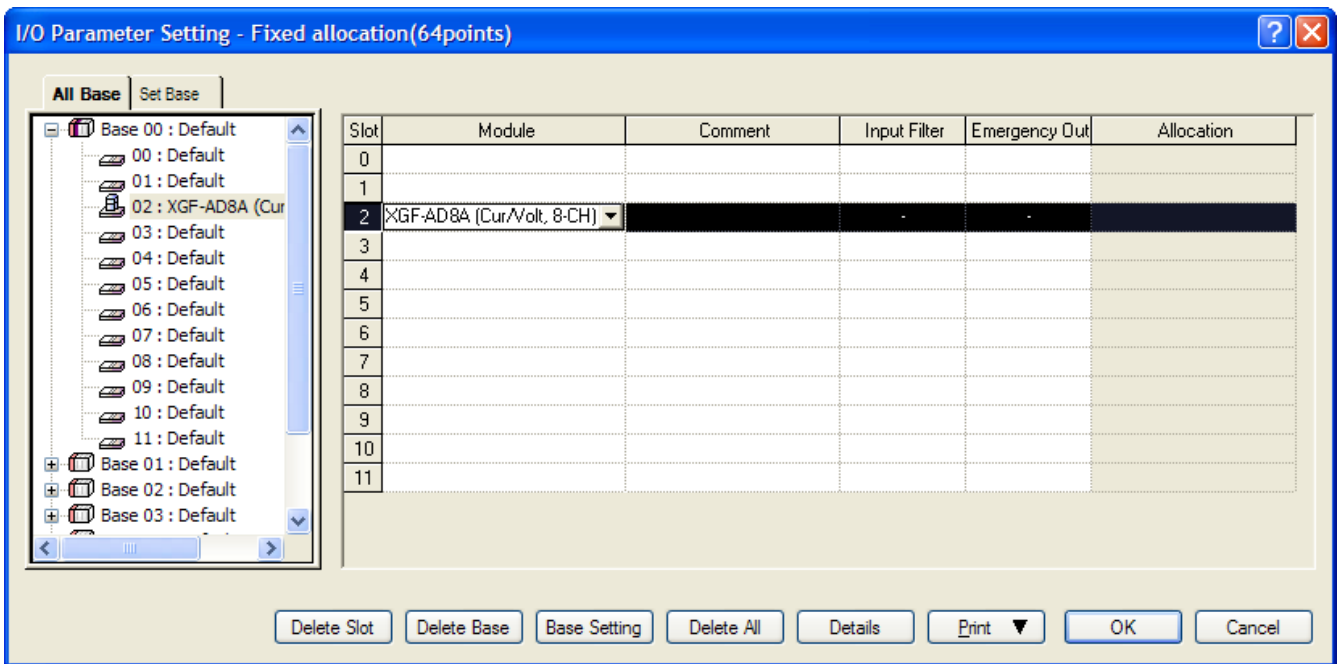

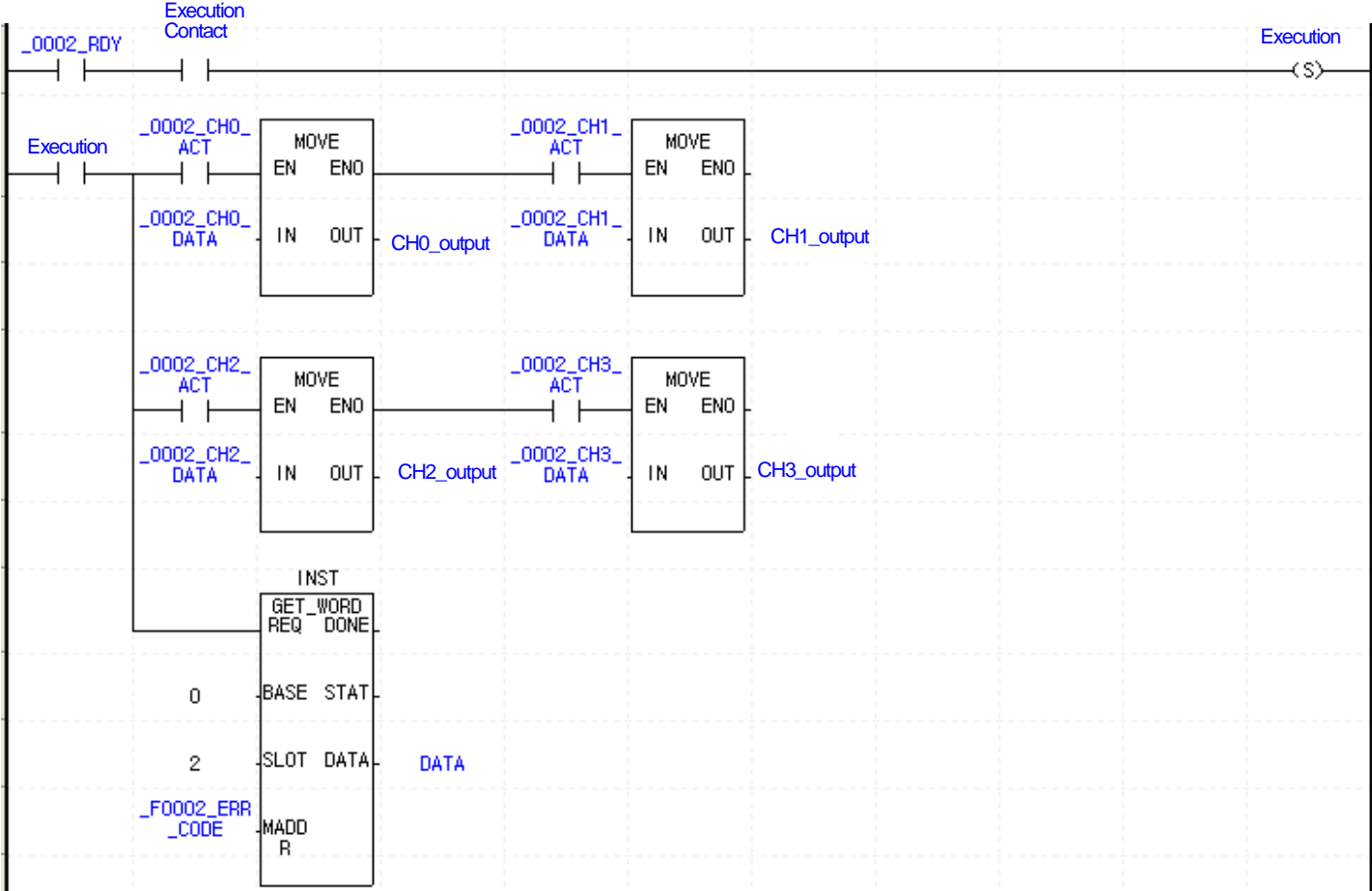

8.1.2 An Example of a Program That Uses the PUT/GET Command

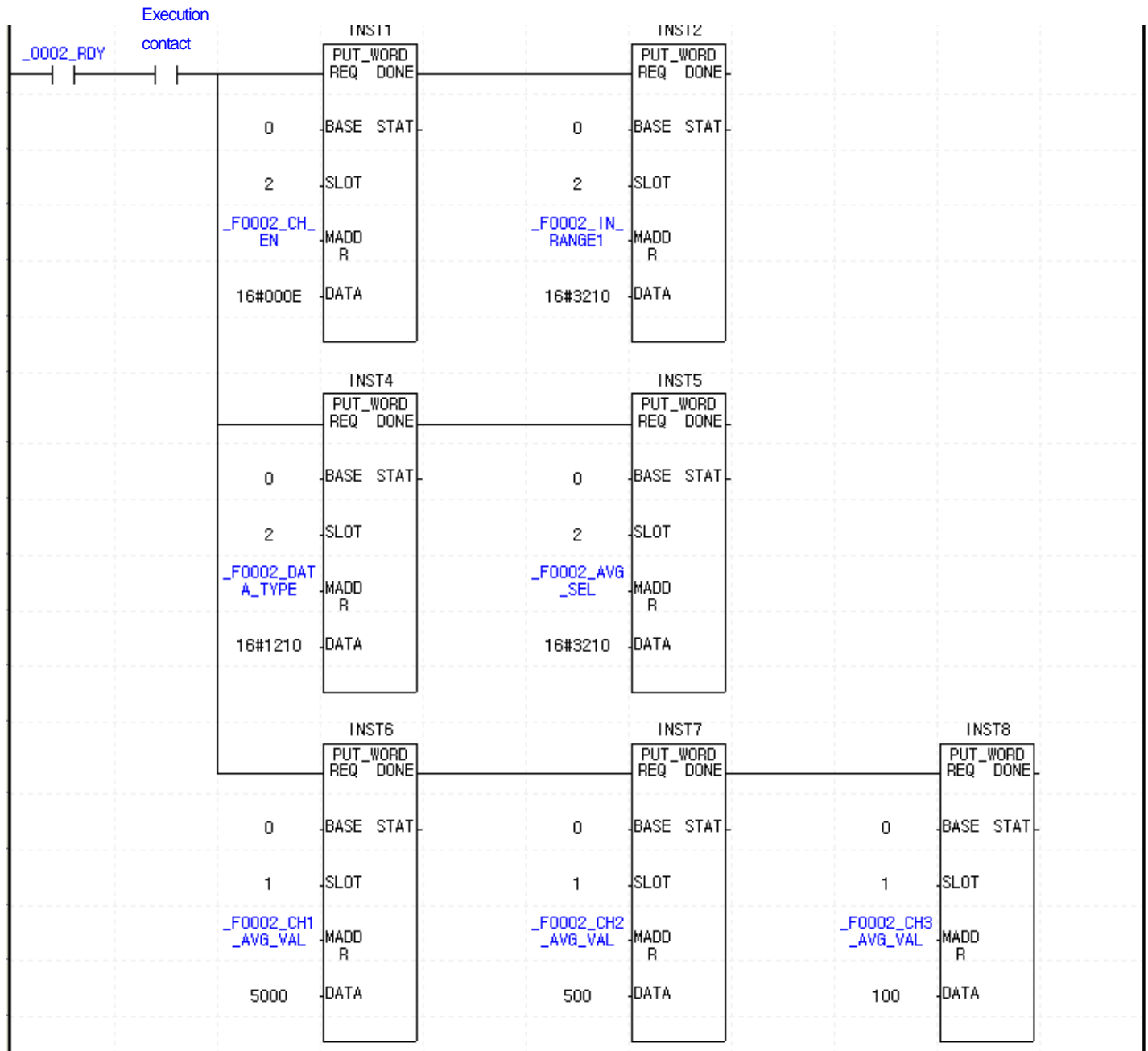

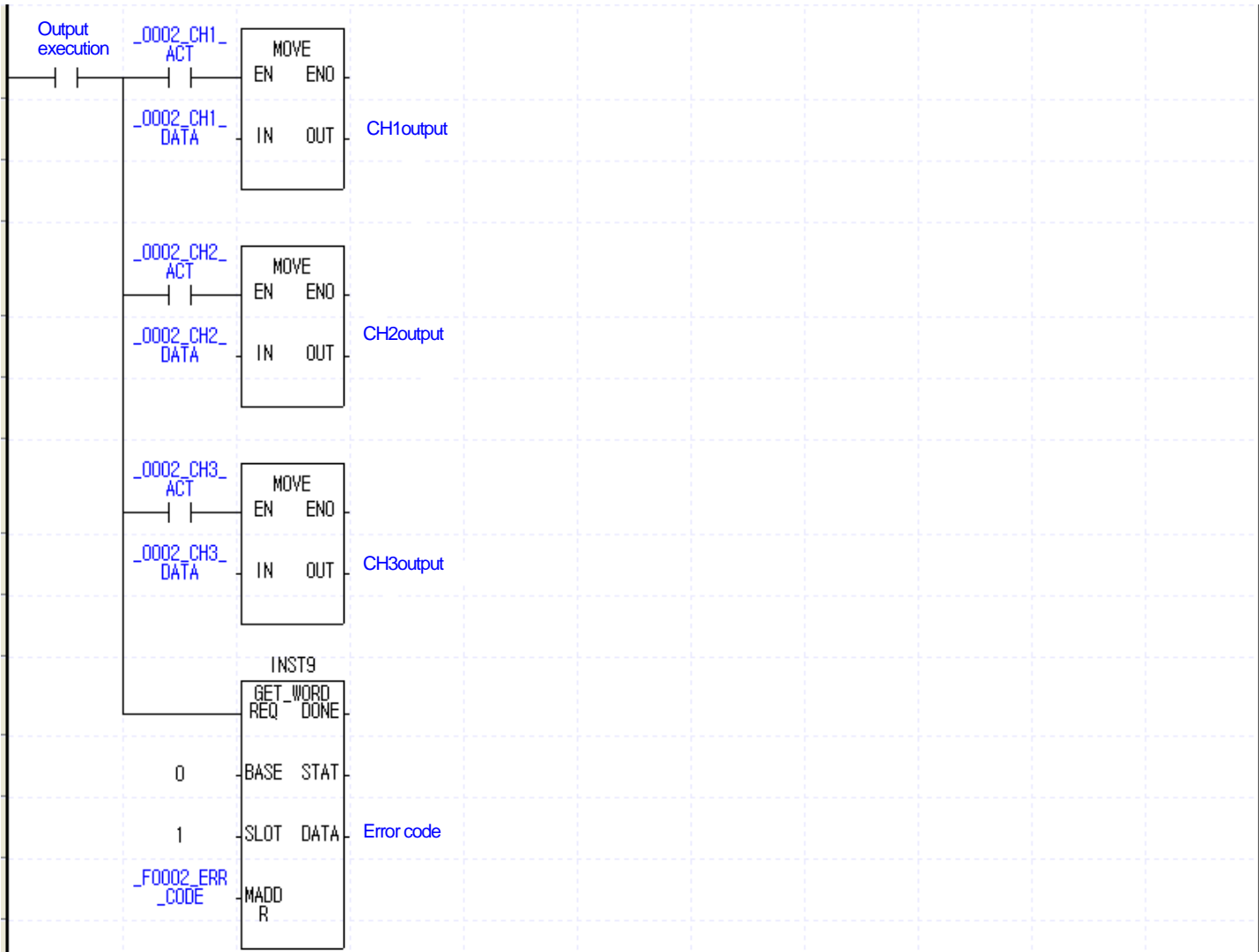

**8.2 Application Program (XGI/XGR)**

**8.2.1 The Program Distinguishing A/D Conversion Values (I/O slot fixed point allocation: 64 points)**

(1) System configuration

|              |              |              |               |              |  |
|--------------|--------------|--------------|---------------|--------------|--|
| XGP-<br>ACF2 | XGI-<br>CPUJ | XGI-<br>D24A | XGF-<br>AD16A | XGQ-<br>RY2A |  |
|--------------|--------------|--------------|---------------|--------------|--|

(2) Initial setting

| No. | Item               | Initial setting                       | Internal memory address | Values to write in internal memory |
|-----|--------------------|---------------------------------------|-------------------------|------------------------------------|
| 1   | Channel in use     | channel 0, channel 2, channel 3       | 0                       | 'h000D' or '13'                    |
| 2   | Input range        | -10 ~ 10 V                            | 1                       | 'h5505' or '21765'                 |
| 3   | Output data range  | -10000 ~ 10000                        | 2                       | 'h0000' or '0'                     |
| 4   | Average processing | Channel 0,2,3(weighted, number, time) | 3                       | 'h1204' or '4612'                  |
| 5   | Average            | Channel 0 weighted average: 50(%)     | 4                       | 'h0032' or '50'                    |
|     |                    | Channel 2 number average: 100(times)  | 6                       | 'h0064' or '100'                   |
|     |                    | Channel 3 time average: 200(ms)       | 7                       | 'h00C8' or '200'                   |

(3) Program description

- (a) When the digital value of channel 0 is smaller than 12000, contact point 0 (%QX0.2.0) of the relay output module mounted in slot 2 is On.
- (b) When the digital value of channel 2 is greater than 13600, contact point 2 (%QX0.2.2) of the relay output module mounted in slot 2 is On.
- (c) When the digital value of channel 3 is greater than or equal to 12000 and smaller than or equal to 13600, contact point 4 (QX0.2.4) of the relay output module mounted in slot 2 is On.
- (d) When the digital value of channel 3 is 13600, contact point 5 (QX0.2.5) of the relay output module mounted in slot 2 is On.

(4) Program

(a) An example of the program that uses [I/O parameter] setting

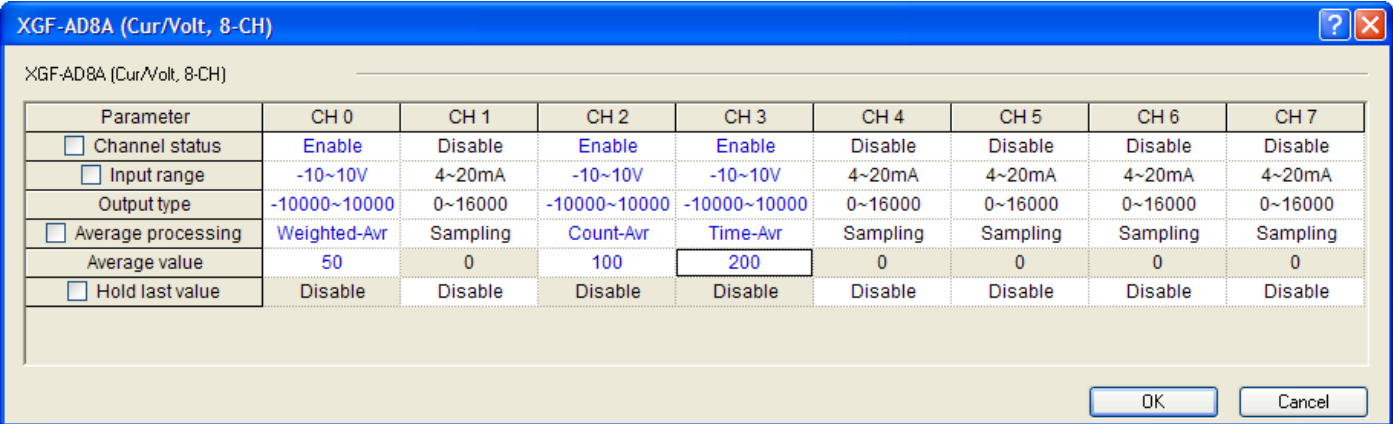
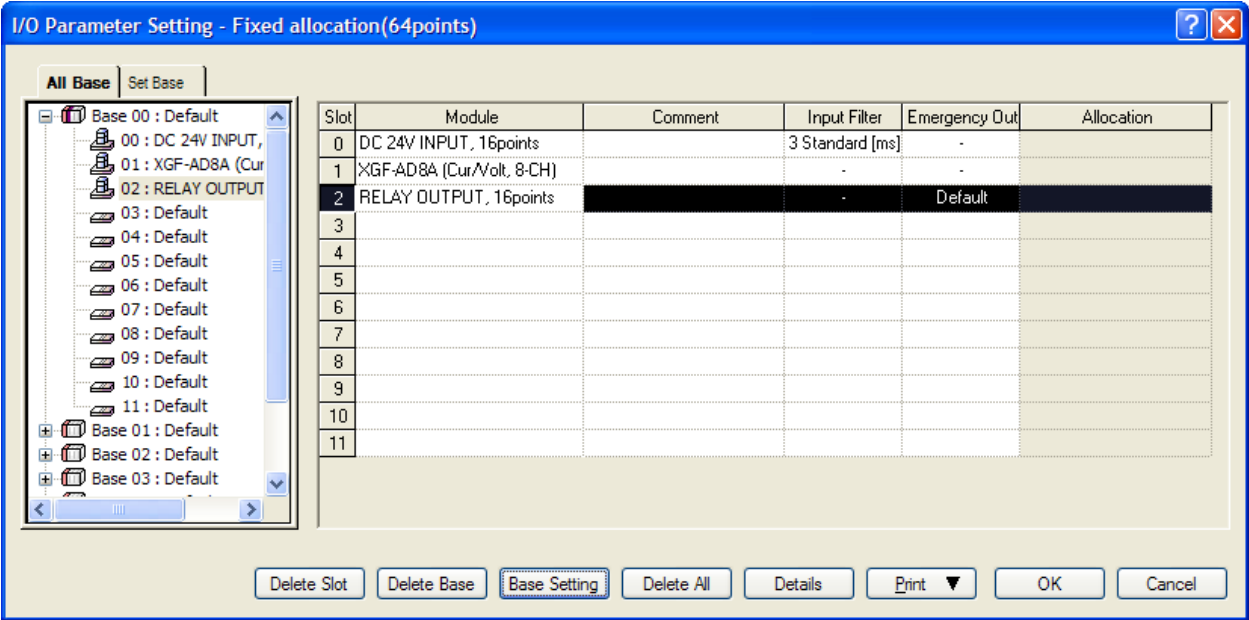

(b) An example of the program that uses PUT/GET command

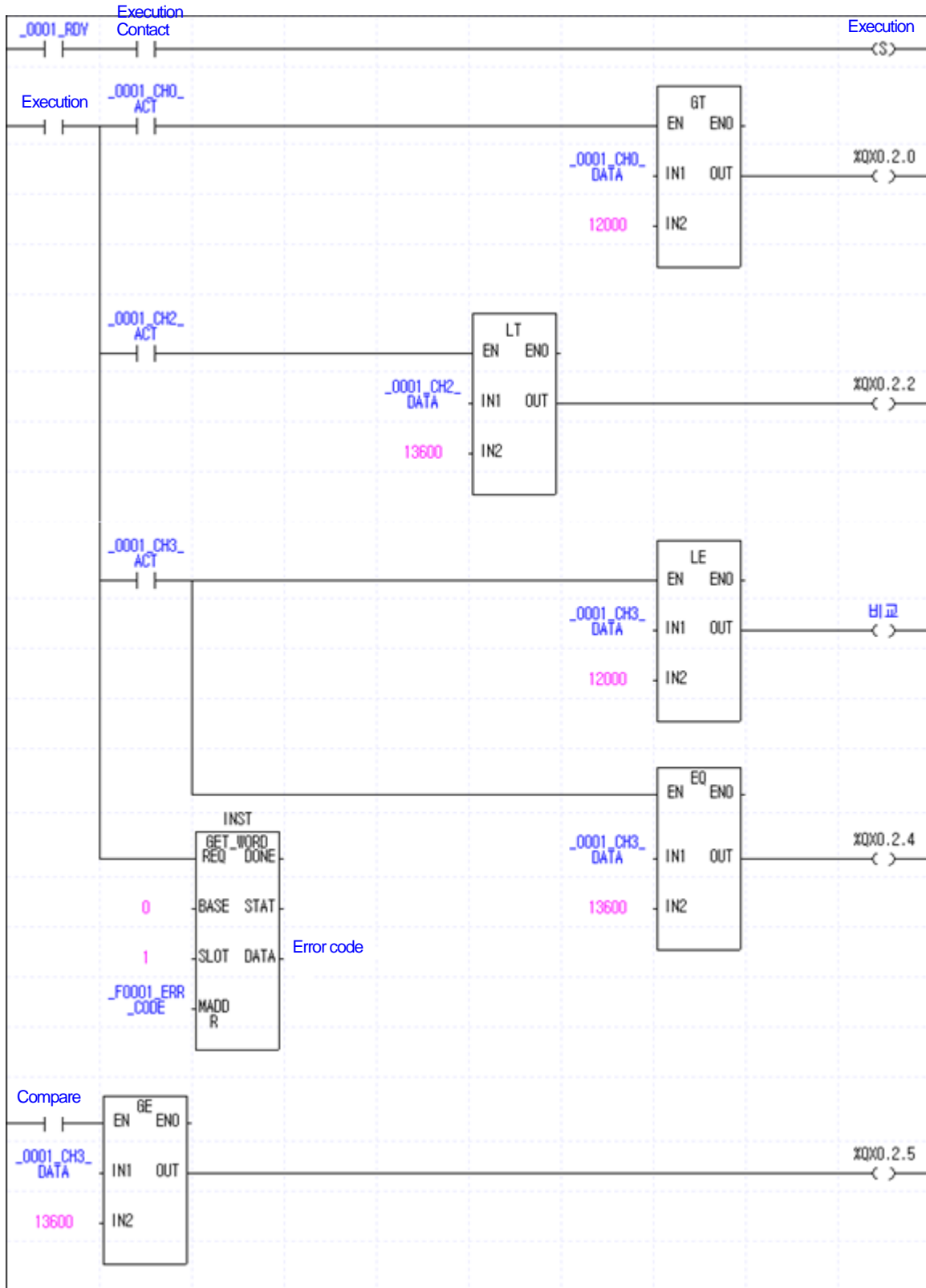

### 8.2.2 The Program That Outputs the Error Code of the Analog Input Module through BCD Display

(1) System configuration

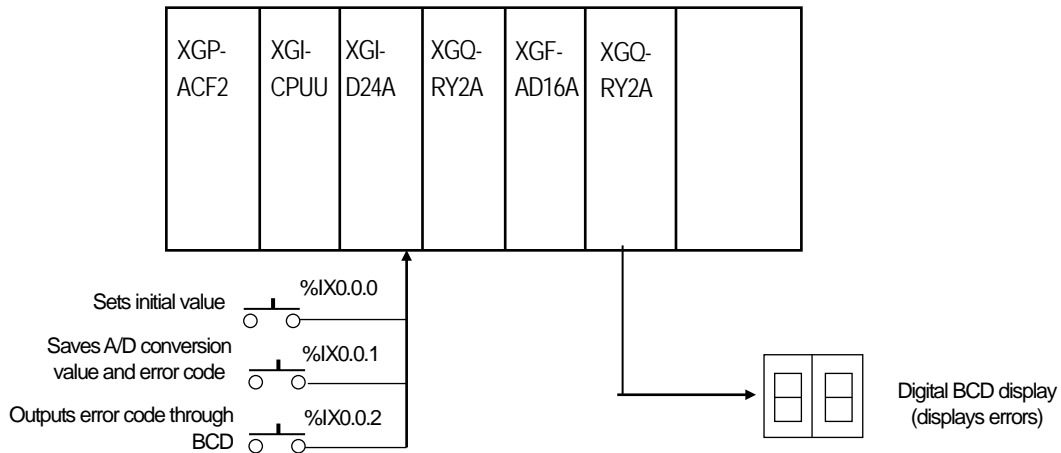

(2) Initial setting

- (a) Channel in use: channel 0
- (b) Analog input current range: DC 4 ~ 20 mA
- (c) Time average processing: 100 (ms)
- (d) Digital output data range: 0 ~ 16000

(3) Program description

- (a) When %IX.0.0.1 is On, the A/D conversion value and error code are respectively saved as conversion value and error code.
- (b) When %IX.0.0.2 is On, the error code is output in the digital BCD display ( %QW.0.3.0).

(4) Program

- (a) An example of the program that uses [I/O parameter] setting

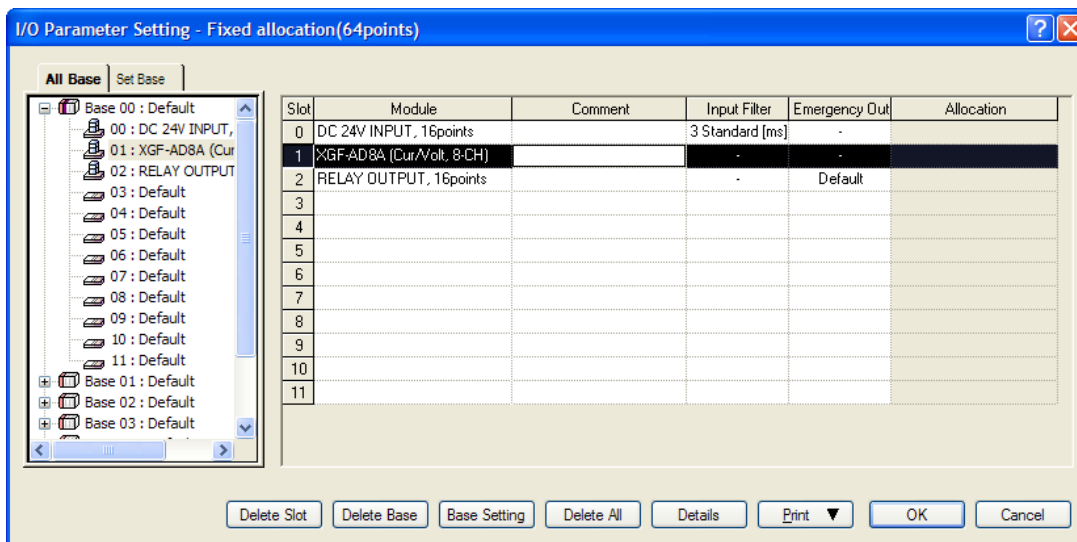

XGF-AD8A (Cur/Volt, 8-CH)

| Parameter                                   | CH 0     | CH 1     | CH 2     | CH 3     | CH 4     | CH 5     | CH 6     | CH 7     |
|---|----------|----------|----------|----------|----------|----------|----------|----------|
| <input type="checkbox"/> Channel status     | Enable   | Disable  | Disable  | Disable  | Disable  | Disable  | Disable  | Disable  |
| <input type="checkbox"/> Input range        | 4~20mA   | 4~20mA   | 4~20mA   | 4~20mA   | 4~20mA   | 4~20mA   | 4~20mA   | 4~20mA   |
| Output type                                 | 0~16000  | 0~16000  | 0~16000  | 0~16000  | 0~16000  | 0~16000  | 0~16000  | 0~16000  |
| <input type="checkbox"/> Average processing | Time-Avr | Sampling | Sampling | Sampling | Sampling | Sampling | Sampling | Sampling |
| Average value                               | 100      | 0        | 100      | 200      | 0        | 0        | 0        | 0        |
| <input type="checkbox"/> Hold last value    | Disable  | Disable  | Disable  | Disable  | Disable  | Disable  | Disable  | Disable  |

4~16000

OK Cancel

(b) An example of the program that uses [I/O parameter] setting

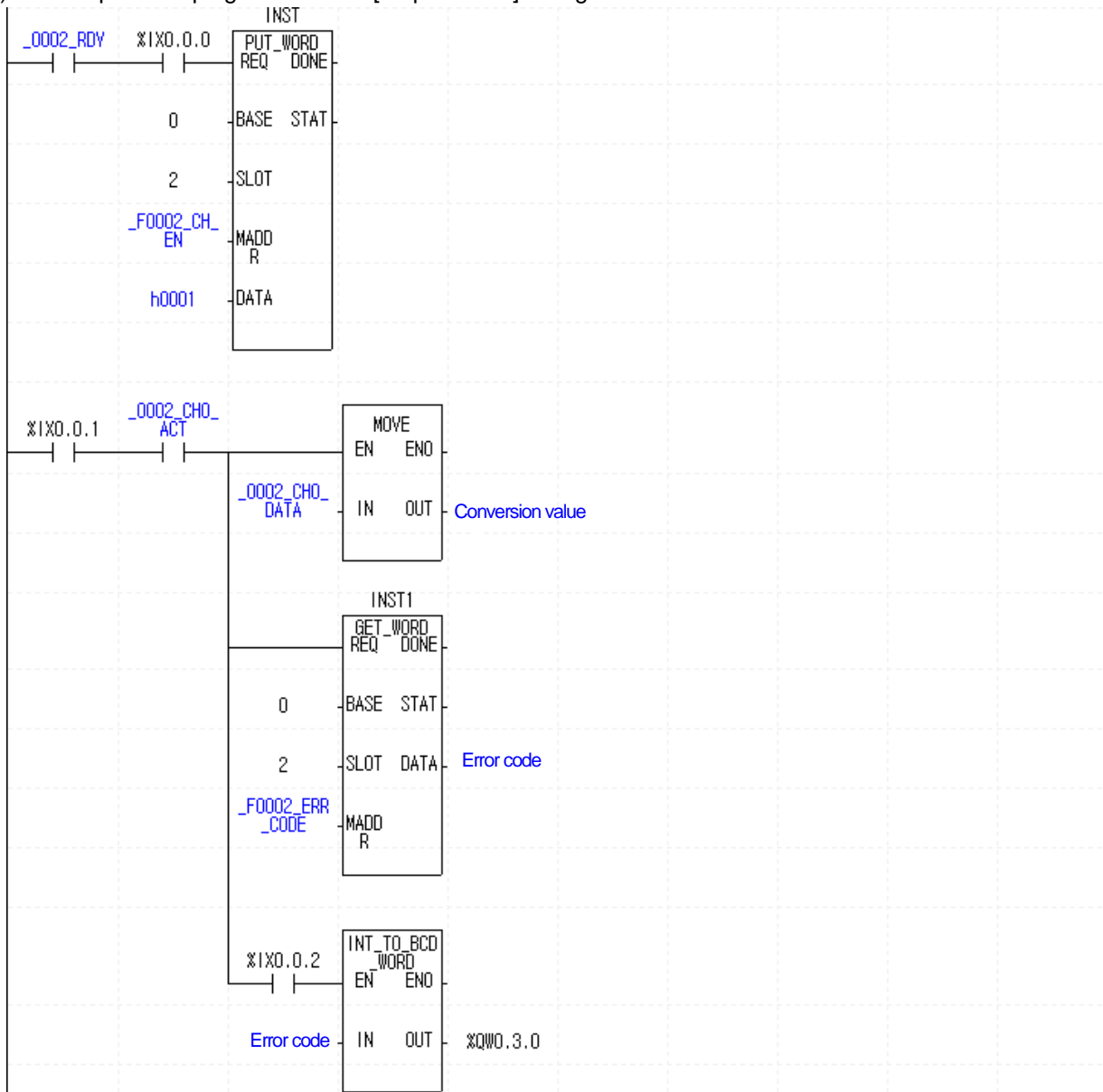



## Chapter 9 Failure Check

This chapter provides information on the errors and failure check of the analog input module.

### 9.1 Error Code

Table 9.1 shows the errors that occur when the RUN LED of the analog input module flashes.

The error code detected in the analog input module is saved in address 25.

[Table 9. 1] Error code list

| Error code (Decimal) | Description of the error   | RUN LED                          |
|----------------------|--|----------------------------------|
| 10                   | module error (ASIC Reset Error)  | RUN LED flashes every 0.2 second |
| 11                   | module error (ASIC RAM or Register Error)  |                                  |
| 20                   | module error (A/D Conversion Error)  |                                  |
| 40#                  | module error (The offset value of 4 ~ 20 mA is larger than or equal to the gain value)   | RUN LED flashes every second     |
| 41#                  | module error (The offset value of 0 ~ 20 mA is larger than or equal to the gain value.)  |                                  |
| 42#                  | module error (The offset value of 1 ~ 5 V is larger than or equal to the gain value.)    |                                  |
| 43#                  | module error (The offset value of 0 ~ 5 V is larger than or equal to the gain value.)    |                                  |
| 44#                  | module error (The offset value of 0 ~ 10 V is larger than or equal to the gain value.)   |                                  |
| 45#                  | module error (The offset value of -10 ~ 10 V is larger than or equal to the gain value.) |                                  |
| 50#                  | Beyond the time average setting range  |                                  |
| 60#                  | Beyond the number average setting range  |                                  |
| 70#                  | Beyond the weighted average setting range  |                                  |
| -                    | Disconnection detected   | RUN LED flashes every 2 second   |

#### Note

- (1) # of the error code means the channel where the error occurred.
- (2) If there are two or more errors, the module saves the error code that happened first and does not save the following error codes.
- (3) If you use an error clear request flag, you can delete the error code in the sequence program (see 5.2.5).

## 9.2 Failure Check

### 9.2.1 RUN LED Flashes.

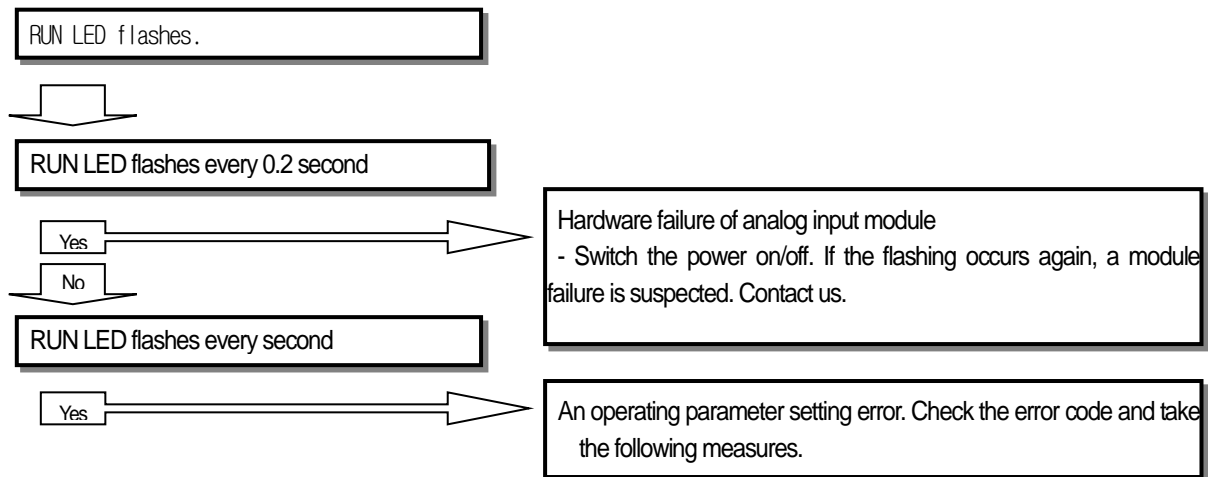

| Error code (Decimal) | Description of the error                  | Action   |
|----------------------|---|--|
| 40#                  | Module offset/gain error                  | Hardware failure of analog input module<br>- Switch the power on/off. If the flashing occurs again, a module failure is suspected. Contact us. |
| 41#                  |   |  |
| 42#                  |   |  |
| 43#                  |   |  |
| 44#                  |   |  |
| 45#                  |   |  |
| 50#                  | Beyond the time average setting range     | Change the set value to 4 ~ 16000.   |
| 60#                  | Beyond the number average setting range   | Change the set value to 2 ~ 64000.   |
| 70#                  | Beyond the weighted average setting range | Change the set value to 1 ~ 99.  |

※ # of the error code means the channel where the error occurred.

9.2.2 RUN LED is Off.

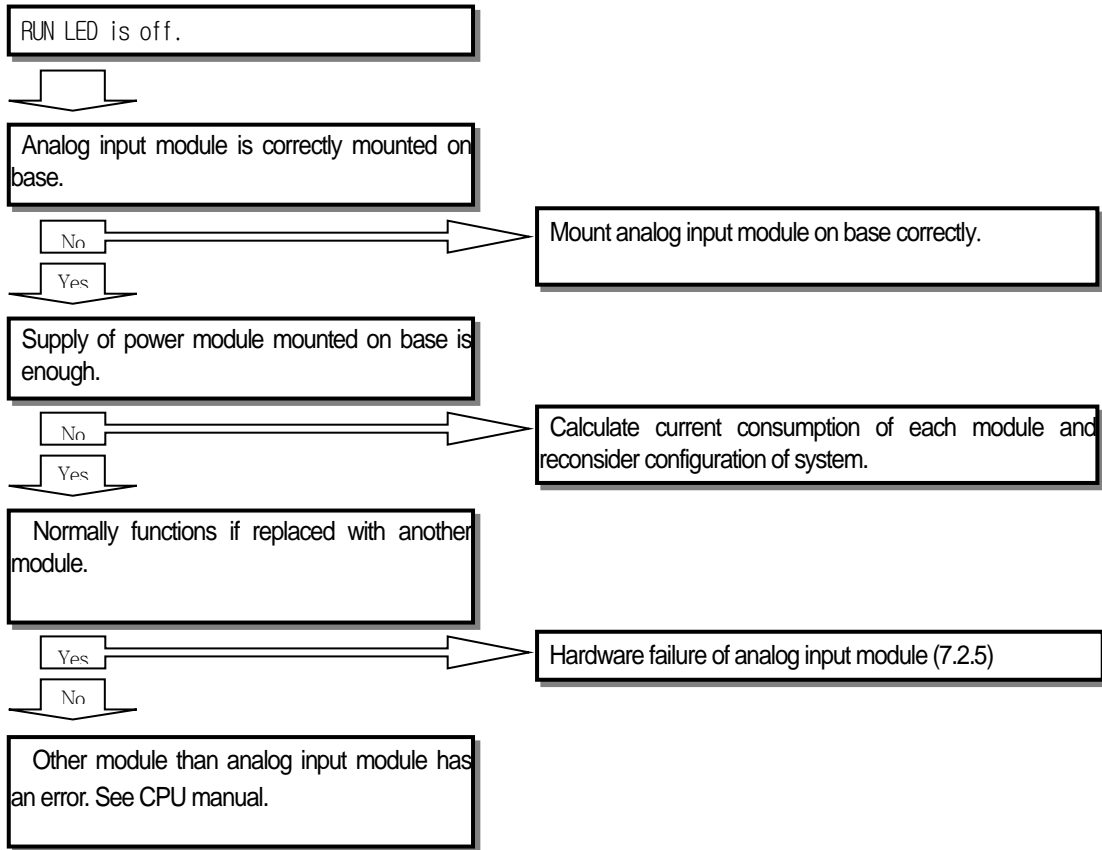

9.2.3 CPU Module Cannot Read A/D Conversion Values.

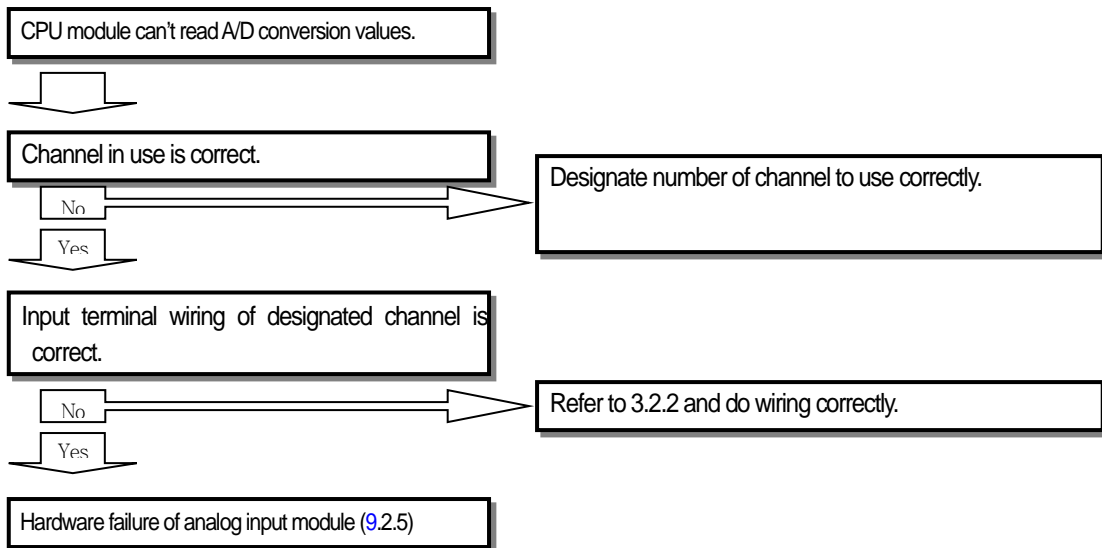

## 9.2.4 The Analog Input Value Inconsistent with Digital Output Value

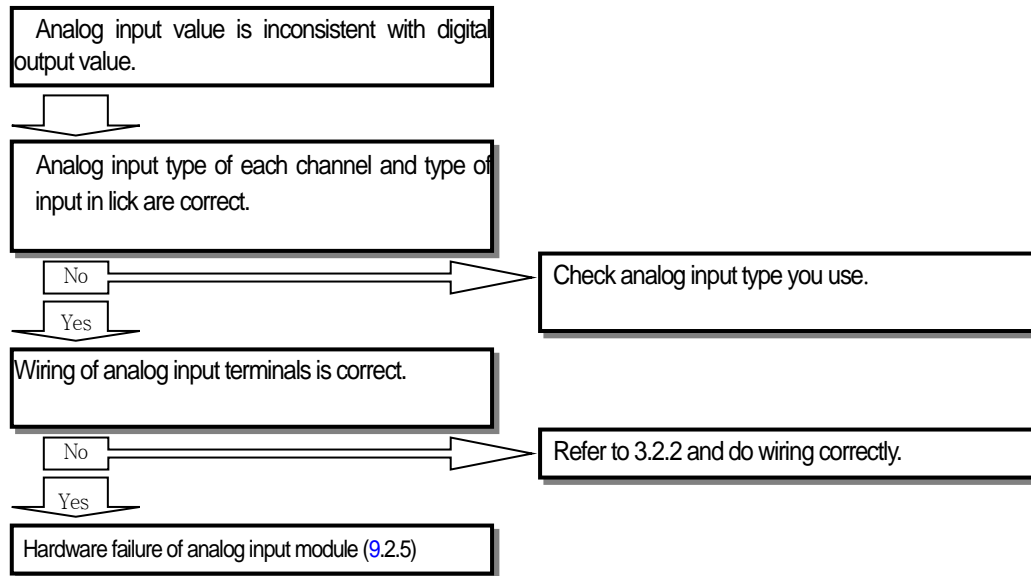

## 9.2.5 Hardware Failure of the Analog Input Module

Switch on/off the power. If it occurs again, a module failure is suspected. Contact us.

## 9.2.6 Check of Analog Input Module Status by XG5000 System Monitor

You can check the module type, information, OS version and status of the analog input module by system monitor of XG5000.

### (1) Sequence

You can do the job either ways.

- (a) [Monitor] -> [System monitor] -> press right button of mouse on module figure -> [module information]
- (b) [Monitor] -> [System monitor] -> double-click on module figure

### (2) Module information

- (a) Module type: displays the information of the currently mounted module.
- (b) Module information: displays the OS version information of the analog input module.
- (c) OS version: displays the data when the analog input module OS was configured.
- (d) Module status: displays the current error code (for details, see Table 7.1).

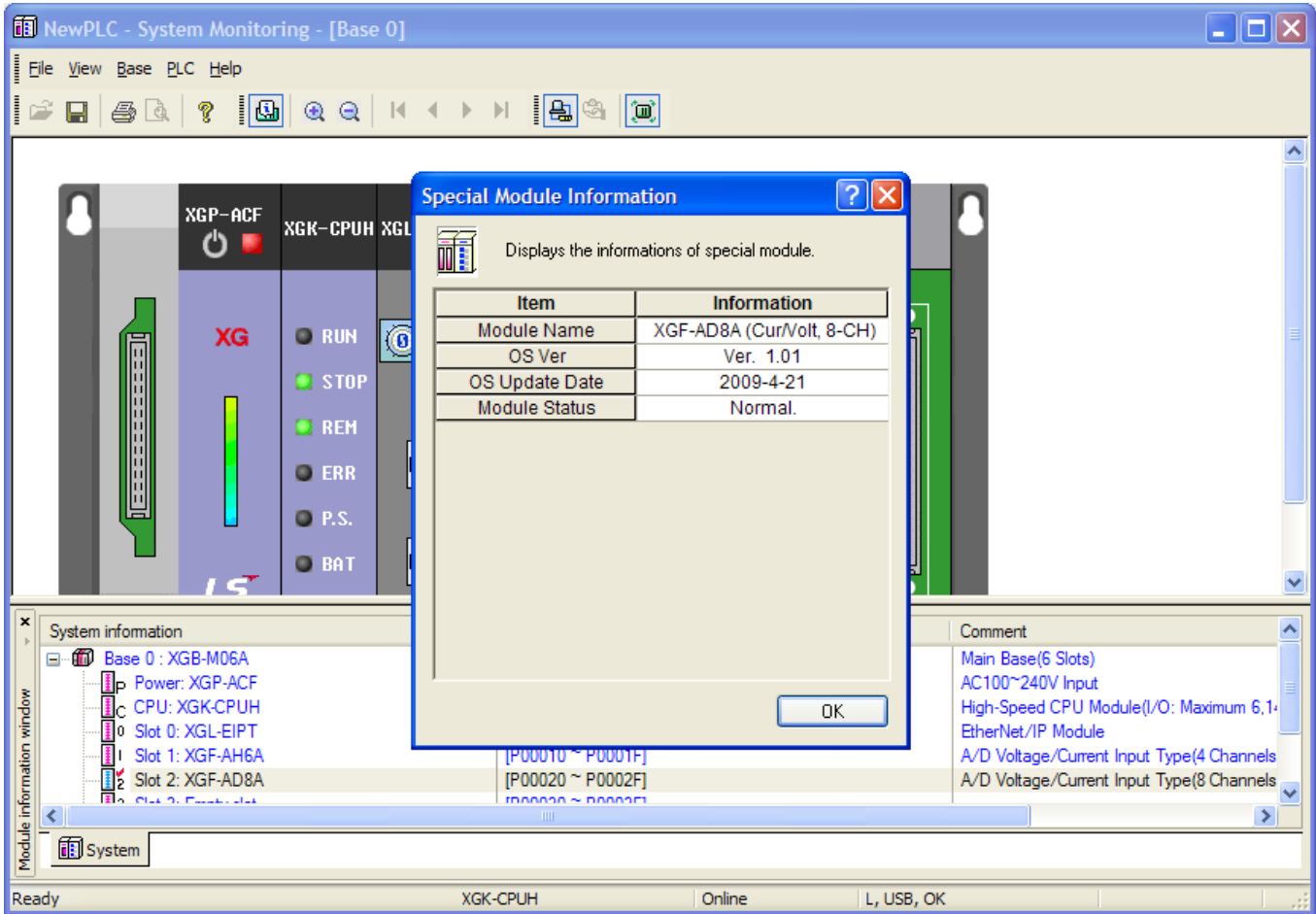



### Appendix 1 Glossary

The following glossary covers the manual and the entire analog module.

- **A/D converter:** converts the analog input signals into digital values in proportion to the magnitude of the signals.
- **Analog input module:** The module that has a circuit which converts analog voltage/current input signals into digital values. It has 14 or 16 bit resolutions according to the converter.
- **Channel:** Related to the terminals of the analog input/output module, each channel is linked to various current/voltage input and output devices and has the functions of data and check.
- **Conversion time:** The time it takes for the analog input module samples and converts the analog signals and then for the processor in the module to receive the converted digital values. In addition, this is the time for the digital values from the processor in the module to be converted into analog output signals and transmitted to the output channel.
- **D/A converter:** Performs the function of producing analog voltage and current signals of continuous size in proportion to the digital value.
- **Full scale:** The magnitude of voltage and current at which normal function is performed.
- **Full scale error:** The difference between an ideal analog conversion value and real analog conversion value on the graph.
- **Full scale range:** The difference between the maximum and minimum of the analog inputs.
- **LSB (Least Significant Bit):** The minimum of the unit bit line.

- **Linearity error:** The analog inputs and outputs being related to continuous voltage/current and digital values, ideal inputs and outputs are defines as a straight line within minimum 1LSB of voltage/current. The difference between an ideal analog conversion value and real analog conversion value on the graph is referred to as a linearity error.

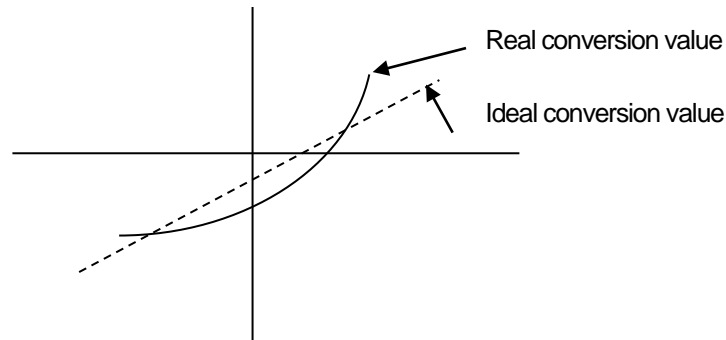

- **Multiplexer:** The switching circuit where multiple circuits share a single A/D converter or D/A converter.
- **Analog output module:** The module that has an output module which converts the analog DC voltage or current signals in proportion to the digital values transmitted from the processor to the module.
- **Resolution:** The minimum value that can be recognized in the measure. It is expressed in engineering units (1mV or number of Bits) in general. That is, 14 Bit is capable of 16383 types of outputs.
- **Filter:** The device that softens the change of digital conversion values of an analog circuit produced from a sudden change of external noise or inputs. It has two methods of SW and HW filters.
- **Precision:** The maximum deviation of the ideal output voltage and current against the pre-output range. With respect to the outputs, it is expressed as the maximum difference between the ideal value in the whole input range and the digital conversion value of the input signals. It is mainly expressed in percentage to the full scale. The error includes the gain, offset and linearity errors.
- **Output precision:** The difference between an real analog output voltage/current value and ideal conversion value on the graph. It is expressed against the full scale, and the error includes the gain, offset and linearity errors. It is expressed respectively in room temperature (25°C) and use temperature ranges.

Appendix 2 Dimension

Unit : mm

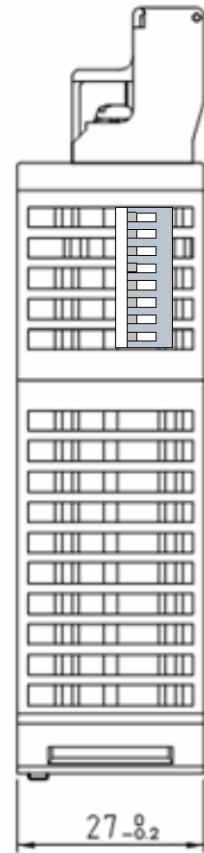
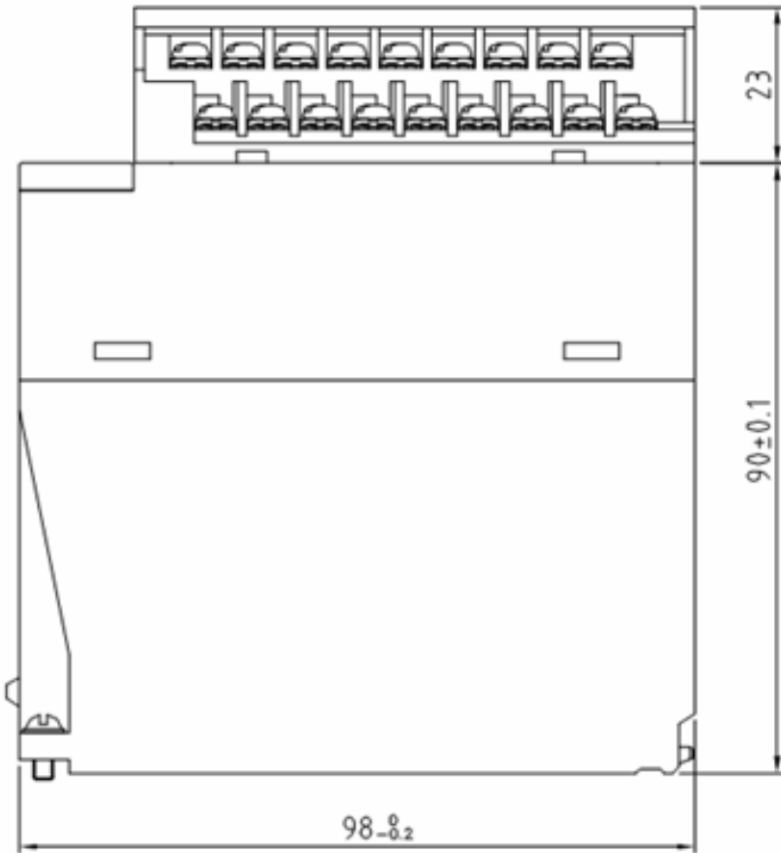
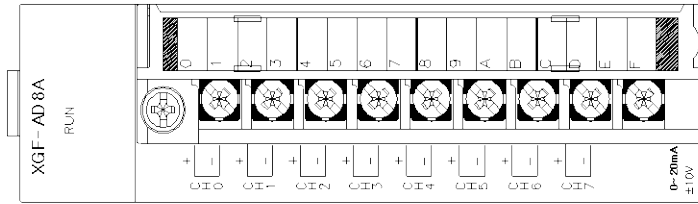



## Warranty

1. Warranty Period

The product you purchased will be guaranteed for 18 months from the date of manufacturing.

2. Scope of Warranty

Any trouble or defect occurring for the above-mentioned period will be partially replaced or repaired. However, please note the following cases will be excluded from the scope of warranty.

- (1) Any trouble attributable to unreasonable condition, environment or handling otherwise specified in the manual,
- (2) Any trouble attributable to others' products,
- (3) If the product is modified or repaired in any other place not designated by the company,
- (4) Due to unintended purposes
- (5) Owing to the reasons unexpected at the level of the contemporary science and technology when delivered.
- (6) Not attributable to the company; for instance, natural disasters or fire

3. Since the above warranty is limited to PLC unit only, make sure to use the product considering the safety for system configuration or applications.

## Environmental Policy

LS ELECTRIC Co., Ltd supports and observes the environmental policy as below.

### Environmental Management

LS ELECTRIC considers the environmental preservation as the preferential management subject and every staff of LS ELECTRIC use the reasonable endeavors for the pleasurable environmental preservation of the earth.

### About Disposal

LS ELECTRIC' PLC unit is designed to protect the environment. For the disposal, separate aluminum, iron and synthetic resin (cover) from the product as they are reusable.





[www.ls-electric.com](http://www.ls-electric.com)

## LS ELECTRIC Co., Ltd.

### ■ Headquarter

LS-ro 127(Hogye-dong) Dongan-gu, Anyang-si, Gyeonggi-Do, 14119, Korea

### ■ Seoul Office

LS Yongsan Tower, 92, Hangang-daero, Yongsan-gu, Seoul, 04386, Korea

Tel: 82-2-2034-4033, 4888, 4703 Fax: 82-2-2034-4588

E-mail: [automation@ls-electric.com](mailto:automation@ls-electric.com)

### ■ Overseas Subsidiaries

#### • LS ELECTRIC Japan Co., Ltd. (Tokyo, Japan)

Tel: 81-3-6268-8241 E-Mail: [japan@ls-electric.com](mailto:japan@ls-electric.com)

#### • LS ELECTRIC (Dalian) Co., Ltd. (Dalian, China)

Tel: 86-411-8730-6495 E-Mail: [china.dalian@lselectric.com.cn](mailto:china.dalian@lselectric.com.cn)

#### • LS ELECTRIC (Wuxi) Co., Ltd. (Wuxi, China)

Tel: 86-510-6851-6666 E-Mail: [china.wuxi@lselectric.com.cn](mailto:china.wuxi@lselectric.com.cn)

#### • LS ELECTRIC Middle East FZE (Dubai, U.A.E.)

Tel: 971-4-886-5360 E-Mail: [middleeast@ls-electric.com](mailto:middleeast@ls-electric.com)

#### • LS ELECTRIC Europe B.V. (Hoofddorp, Netherlands)

Tel: 31-20-654-1424 E-Mail: [europartner@ls-electric.com](mailto:europartner@ls-electric.com)

#### • LS ELECTRIC America Inc. (Chicago, USA)

Tel: 1-800-891-2941 E-Mail: [sales.us@lselectricamerica.com](mailto:sales.us@lselectricamerica.com)

#### • LS ELECTRIC Turkey Co., Ltd.

Tel: 90-212-806-1225 E-Mail: [turkey@ls-electric.com](mailto:turkey@ls-electric.com)

### ■ Overseas Branches

#### • LS ELECTRIC Tokyo Office (Japan)

Tel: 81-3-6268-8241 E-Mail: [tokyo@ls-electric.com](mailto:tokyo@ls-electric.com)

#### • LS ELECTRIC Beijing Office (China)

Tel: 86-10-5095-1631 E-Mail: [china.auto@lselectric.com.cn](mailto:china.auto@lselectric.com.cn)

#### • LS ELECTRIC Shanghai Office (China)

Tel: 86-21-5237-9977 E-Mail: [china.auto@lselectric.com.cn](mailto:china.auto@lselectric.com.cn)

#### • LS ELECTRIC Guangzhou Office (China)

Tel: 86-20-3818-2883 E-Mail: [china.auto@lselectric.com.cn](mailto:china.auto@lselectric.com.cn)

#### • LS ELECTRIC Chengdu Office (China)

Tel: 86-28-8670-3201 E-Mail: [china.auto@lselectric.com.cn](mailto:china.auto@lselectric.com.cn)

#### • LS ELECTRIC Qingdao Office (China)

Tel: 86-532-8501-2065 E-Mail: [china.auto@lselectric.com.cn](mailto:china.auto@lselectric.com.cn)

#### • LS ELECTRIC Nanjing Office (China)

Tel: 86-25-8467-0005 E-Mail: [china.auto@lselectric.com.cn](mailto:china.auto@lselectric.com.cn)

#### • LS ELECTRIC Bangkok Office (Thailand)

Tel: 66-90-950-9683 E-Mail: [thailand@ls-electric.com](mailto:thailand@ls-electric.com)

#### • LS ELECTRIC Jakarta Office (Indonesia)

Tel: 62-21-2933-7614 E-Mail: [indonesia@ls-electric.com](mailto:indonesia@ls-electric.com)

#### • LS ELECTRIC Moscow Office (Russia)

Tel: 7-499-682-6130 E-Mail: [info@lselectric-ru.com](mailto:info@lselectric-ru.com)

#### • LS ELECTRIC America Western Office (Irvine, USA)

Tel: 1-949-333-3140 E-Mail: [america@ls-electric.com](mailto:america@ls-electric.com)

### Disclaimer of Liability

LS ELECTRIC has reviewed the information in this publication to ensure consistency with the hardware and software described. However, LS ELECTRIC cannot guarantee full consistency, nor be responsible for any damages or compensation, since variance cannot be precluded entirely. Please check again the version of this publication before you use the product.

© LS ELECTRIC Co., Ltd 2006 All Right Reserved.

2022.08