

The right choice for the ultimate yield!

LS ELECTRIC strives to maximize your profits in gratitude for choosing us as your partner.

Programmable Logic Control

Analog Input Module

(Isolated type for 2 wire transmitter)

XGT Series

User Manual

XGF-AW4S



Safety Instructions

- Read this manual carefully before installing, wiring, operating, servicing or inspecting this equipment.
- Keep this manual within easy reach for quick reference.

LSELECTRIC

Before using the product ...

For your safety and effective operation, please read the safety instructions thoroughly before using the product.

- ▶ Safety Instructions should always be observed in order to prevent accident or risk with the safe and proper use the product.
- ▶ Instructions are divided into “Warning” and “Caution”, and the meaning of the terms is as follows.



This symbol indicates the user is expected risk of death or serious injury in case of incorrect handling



This symbol indicates the user is expected risk of injury or property damage only in case of incorrect handling

Moreover, even classified events under its caution category may develop into serious accidents relying on situations. Therefore we strongly advise users to observe all precautions properly just like warnings.

- ▶ The marks displayed on the product and in the user’s manual have the following meanings.

 Be careful! Danger may be expected.

 Be careful! Electric shock may occur.

- ▶ The user’s manual even after read shall be kept available and accessible to any user of the product.

Safety Instructions for design process

Warning

- ▶ **Please install a protection circuit on the exterior of PLC so that the whole system may operate safely regardless of failures from external power or PLC.** Any abnormal output or operation from PLC may cause serious problems to safety in whole system.
 - Install protection units on the exterior of PLC like an interlock circuit that deals with opposite operations such as emergency stop, protection circuit, and forward/reverse rotation or install an interlock circuit that deals with high/low limit under its position controls.
 - If any system error (watch-dog timer error, module installation error, etc.) is detected during CPU operation in PLC, all output signals are designed to be turned off and stopped for safety. However, there are cases when output signals remain active due to device failures in Relay and TR which can't be detected. Thus, you are recommended to install an addition circuit to monitor the output status for those critical outputs which may cause significant problems.

- ▶ **Never overload more than rated current of output module nor allow to have a short circuit.** Over current for a long period time may cause a fire.

- ▶ **Never let the external power of the output circuit to be on earlier than PLC power,** which may cause accidents from abnormal output or operation.

- ▶ **Please install interlock circuits in the sequence program for safe operations in the system when exchange data with PLC or modify operation modes using a computer or other external equipments** Read specific instructions thoroughly when conducting control operations with PLC.

Safety Instructions for design process

Caution

- ▶ **I/O signal or communication line shall be wired at least 100mm away from a high-voltage cable or power line.** Fail to follow this instruction may cause malfunctions from noise

Safety Instructions on installation process

Caution

- ▶ **Use PLC only in the environment specified in PLC manual or general standard of data sheet.** If not, electric shock, fire, abnormal operation of the product may be caused.
- ▶ **Before install or remove the module, be sure PLC power is off.** If not, electric shock or damage on the product may be caused.
- ▶ **Be sure that every module is securely attached after adding a module or an extension connector.** If the product is installed loosely or incorrectly, abnormal operation, error or dropping may be caused. In addition, contact failures under poor cable installation will be causing malfunctions as well.
- ▶ **Be sure that screws get tighten securely under vibrating environments.** Fail to do so will put the product under direct vibrations which will cause electric shock, fire and abnormal operation.
- ▶ **Do not come in contact with conducting parts in each module,** which may cause electric shock, malfunctions or abnormal operation.

Safety Instructions for wiring process

Warning

- ▶ **Prior to wiring works, make sure that every power is turned off.** If not, electric shock or damage on the product may be caused.
- ▶ **After wiring process is done, make sure that terminal covers are installed properly before its use.** Fail to install the cover may cause electric shocks.

Caution

- ▶ **Check rated voltages and terminal arrangements in each product prior to its wiring process.** Applying incorrect voltages other than rated voltages and misarrangement among terminals may cause fire or malfunctions.
- ▶ **Secure terminal screws tightly applying with specified torque.** If the screws get loose, short circuit, fire or abnormal operation may be caused. Securing screws too tightly will cause damages to the module or malfunctions, short circuit, and dropping.
- *
 - ▶ **Be sure to earth to the ground using Class 3 wires for PE terminals which is exclusively used for PLC.** If the terminals not grounded correctly, abnormal operation or electric shock may be caused.
 - ▶ **Don't let any foreign materials such as wiring waste inside the module while wiring,** which may cause fire, damage on the product or abnormal operation.
 - ▶ **Make sure that pressed terminals get tighten following the specified torque. External connector type shall be pressed or soldered using proper equipments.**

Safety Instructions for test-operation and maintenance

Warning

- ▶ **Don't touch the terminal when powered.** Electric shock or abnormal operation may occur.
- ▶ **Prior to cleaning or tightening the terminal screws, let all the external power off including PLC power.** If not, electric shock or abnormal operation may occur.
- ▶ **Don't let the battery recharged, disassembled, heated, short or soldered.** Heat, explosion or ignition may cause injuries or fire.

Caution

- ▶ **Do not make modifications or disassemble each module.** Fire, electric shock or abnormal operation may occur.
- ▶ **Prior to installing or disassembling the module, let all the external power off including PLC power.** If not, electric shock or abnormal operation may occur.
- ▶ **Keep any wireless equipment such as walkie-talkie or cell phones at least 30cm away from PLC.** If not, abnormal operation may be caused.
- ▶ **When making a modification on programs or using run to modify functions under PLC operations, read and comprehend all contents in the manual fully.** Mismanagement will cause damages to products and accidents.
- ▶ **Avoid any physical impact to the battery and prevent it from dropping as well.** Damages to battery may cause leakage from its fluid. When battery was dropped or exposed under strong impact, never reuse the battery again. Moreover skilled workers are needed when exchanging batteries.

Safety Instructions for waste disposal



Caution

- ▶ **Product or battery waste shall be processed as industrial waste.** The waste may discharge toxic materials or explode itself.

Revision History

Version	Date	Remark	Revised position
V 1.0	2010.5	1. First Edition	-
V1.1	2015.7	1. Domain address and CI changed 2. General specifications changed by reason of changed IEC specifications	2-1
V1.3	2020.7	1. Format and contents modification according to the change of company name(LSIS → LS ELECTRIC)	
V1.4	2022.6	1. Add disconnection LED display function	2-3

Thank you for purchasing PLC of LS ELECTRIC Co., Ltd.

Before use, make sure to carefully read and understand the User's Manual about the functions, performances, installation and programming of the product you purchased in order for correct use and importantly, let the end user and maintenance administrator to be provided with the User's Manual.

The User's Manual describes the product. If necessary, you may refer to the following description and order accordingly. In addition, you may connect our website (<http://www.ls-electric.com/>) and download the information as a PDF file.

Relevant User's Manuals

Title	Description
XG5000 User's Manual (for XGK, XGB)	XG5000 software user manual describing online function such as programming, print, monitoring, debugging by using XGK, XGB CPU
XG5000 User's Manual (for XGI, XGR)	XG5000 software user manual describing online function such as programming, print, monitoring, debugging by using XGI, XGR CPU
XGK/XGB Instructions & Programming User's Manual	User's manual for programming to explain how to use instructions that are used PLC system with XGK, XGB CPU.
XGI/XGR/XEC Instructions & Programming User's Manual	User's manual for programming to explain how to use instructions that are used PLC system with XGI, XGR, XEC CPU.
XGK CPU User's Manual (XGK-CPUA/CPUE/CPUH/CPUS/CPUU)	XGK-CPUA/CPUE/CPUH/CPUS/CPUU user manual describing about XGK CPU module, power module, base, IO module, specification of extension cable and system configuration, EMC standard
XGI CPU User's Manual (XGI-CPUU/CPUH/CPUS)	XGI-CPUU/CPUH/CPUS user manual describing about XGI CPU module, power module, base, IO module, specification of extension cable and system configuration, EMC standard
XGR redundant series User's Manual	XGR- CPUH/F, CPUH/T user manual describing about XGR CPU module, power module, extension drive, base, IO module, specification of extension cable and system configuration, EMC standard

The User's Manual is based on XGF-AW4S.

This manual is based on the following versions.

Product name	OS version
XGK-CPUH, CPUS, CPUA, CPUE, CPUU	V2,1
XGI-CPUU, CPUH, CPUS	V2.1
XGR-CPUH/F, CPUH/T	V1.6
XG5000(XG-PD)	V3.1

© Table of Content ©

Chapter 1 Overview 1-1 ~ 1-3

1.1 Characteristics	1-1
1.2 Glossary	1-2
1.2.1 Analog Quantity - A	1-2
1.2.2 Digital Quantity - D	1-2
1.2.3 The Characteristics of Analog-Digital Conversion	1-3

Chapter 2 Specification 2-1 ~ 2-15

2.1 General Specifications	2-1
2.2 Performance Specifications	2-2
2.3 Description of the Parts	2-3
2.3.1 XGF-AW4S	2-3
2.4 Characteristics of Input/Output Conversion	2-4
2.4.1 Characteristics of Input/Output	2-4
2.4.2 Precision	2-8
2.5 Functions of the Analog Input Module	2-9
2.5.1 Average Processing	2-9
2.5.2 Alarm Function	2-12
2.5.3 Input Disconnection Detection	2-14

Chapter 3 Installation and Wiring 3-1 ~ 3-4

3.1 Installation	3-1
3.1.1 Installation Environment	3-1
3.1.2 Precautions in Handling	3-1
3.2 Wiring	3-2
3.2.1 Precautions in Wiring	3-2
3.2.2 An Example of Wiring	3-2

Chapter 4 Operating Setting 4-1 ~ 4-18

4.1 The Operating Setting Flowchart	4-1
4.2 Operating Parameter Setting	4-2
4.2.1 Setting Items	4-2
4.2.2 How to Use [I/O parameter].....	4-3
4.3 Functions of the Special Module Monitor	4-9
4.4 Precautions	4-10
4.5 How to Use the Special Module Monitor	4-11
4.5.1 Starting [Special module monitor].....	4-11
4.5.2 How to Use [Special module monitor].....	4-11
4.6 Automatic Registration of U Device	4-15
4.6.1 Automatic Registration of U Device.....	4-15
4.6.2 Saving Variables	4-17
4.6.3 Viewing Variables in the Program	4-17

Chapter 5 Configuration and Function of Internal Memory (XGK) 5-1 ~ 5-13

5.1 The Configuration of the Internal Memory	5-1
5.1.1 Input and Output Data of the 2-Wire Analog Input Module	5-1
5.1.2 Operating Parameter Setting Range	5-3
5.2 A/D Conversion Data Input/Output Ranges	5-4
5.2.1 Module READY/ERROR Flag	5-4
5.2.2 Operating channel flag	5-4
5.2.3 Digital output value	5-4
5.2.4 Process alarm detection flag	5-5
5.2.5 Change rate alarm detection flag	5-5
5.2.6 Disconnection detection flag	5-6
5.2.7 Error clear request flag	5-6
5.3 Operating Parameter Setting Ranges	5-7
5.3.1 Designation of the channel to use (address 0)	5-7
5.3.2 Output Voltage/Current Ranges (Addresses 1).....	5-7
5.3.3 Output Data Ranges (Address 2).....	5-8
5.3.4 Average Processing (Address 3).....	5-8

5.3.5 Average Value (Addresses 4~7)	5-9
5.3.6 Alarm Processing (Address 8)	5-10
5.3.7 Process alarm setting values (Address 9 ~ 24)	5-10
5.3.8 Change rate alarm detection cycle (Addresses 25 ~ 28)	5-11
5.3.9 Change rate alarm setting value (Addresses 29 ~ 36)	5-12
5.3.10 Error Code (Address 37)	5-13

Chapter 6 Programming (XGK)	6-1 ~ 6-10
--	-------------------

6.1 Read/Write of the Operating Parameter Setting Ranges	6-1
6.1.1 Reading the Operating Parameter Setting Ranges (GET, GETP commands)	6-1
6.1.2 Reading Operating Parameter Setting Ranges (PUT, PUTP commands)	6-2
6.2 The Basic Program	6-3
6.2.1 XGF-AW4S	6-3
6.3 Applied Program	6-6
6.3.1 The Program Distinguishing A/D Conversion Values	6-6
6.3.2 The Program That Outputs the Error Code of the 2 Wire Input Analog Input Module through BCD Display	6-8

Chapter 7 Configuration and Function of Global Variable (XGI/XGR)	7-1 ~ 7-19
--	-------------------

7.1 Global Variables (Data Areas)	7-1
7.1.1 Input and Output Ranges of the 2-Wire Input Analog Input Module	7-1
7.1.2 How to Use Global Variables	7-2
7.2 PUT/GET Function Block Ranges (Parameter Area)	7-10
7.2.1 PUT/GET Function Block Ranges (Parameter Area)	7-10
7.2.2 PUT/GET Commands	7-10
7.2.3 Examples of Use of PUT/GET Commands	7-13

Chapter 8 Programming (XGI/XGR)	8-1 ~ 8-10
--	-------------------

8.1 The Basic Program	8-1
8.1.1 Basic program of XGF-AW4S	8-1
8.2 Applied Program	8-6
8.2.1 The Program Distinguishing A/D Conversion Values	8-6

8.2.2 The Program That Outputs the Error Code of the Analog Input Module through BCD Display 8-9

Chapter 9 Failure Check 9-1 ~ 9-5

9.1 Error Code 9-1

9.2 Failure Check 9-2

 9.2.1 RUN LED Flashes 9-2

 9.2.2 RUN LED Is Off 9-3

 9.2.3 CPU Module Cannot Read A/D Conversion Values 9-3

 9.2.4 The Analog Input Value Inconsistent with Digital Output Value 9-4

 9.2.5 Values Cannot Be Monitored during Transmitter Wiring Work 9-4

 9.2.6 Hardware Failure of the 2-Wire Analog Input Module 9-4

 9.2.7 Check of Analog Input Module Status by XG5000 System Monitor 9-5

Appendix 1 Glossary A1-1 ~ A1-2

Appendix 2 Dimension A2-1

Warranty and Environmental Policy

Chapter 1 Overview

This manual describes the specifications, handling, and programming of the XGF-AW4S type 2-wire input analog input module (hereinafter XGF-AW4S), which is used in combination with the CPU module of the XGT PLC series. XGF-AW4S is hereafter referred to as the 2-wire input analog input module. The 2-wire input analog input module is for converting the analog signals (voltage or current input) from a PLC external device into digital values of the signed 16 bit binary data.

1.1 Characteristics

(1) Inter-channel Insulation

Channels are insulated from each other.

(2) High resolution of 1/64000

The resolution of the digital values can be set at 1/64000.

(3) High precision

The conversion precision is $\pm 0.05\%$ (surrounding temperature 25°C) and the temperature coefficient is 70 ppm/°C.

(4) 2-wire transmitter power supply

2-wire transmitter power is supplied. On/Off of the transmitter power hangs on the operation/stop of the channel.

(5) Operating parameter setting and monitoring by GUI(Graphical User Interface)

The operating setting, which was conducted by commands, can be manipulated by using [I/O parameter setting] with improved user interface, which increased the user's convenience. You can reduce the sequence program by using I/O parameter setting. Furthermore, you can easily monitor the A/D converted values using [Special module monitor] function.

(6) A variety of digital output data formats

3 types of digital output data format are supported. The output type of the digital data can be defined as follows.

- Signed value: -32000 ~ 32000
- Precise value: see Chapter 2.2.
- Percentile value: 0 ~ 10000

(7) A variety of A/D conversion methods

Sample processing and average processing (time, frequency, moving and weighted average) are provided.

(8) Alarm function

Process and change rate alarms are provided.

(9) Short circuit detection

A short circuit of the input circuit can be detected when the analog input sign range of 4 ~ 20 mA, 1 ~ 5 V is used.

1.2 Glossary

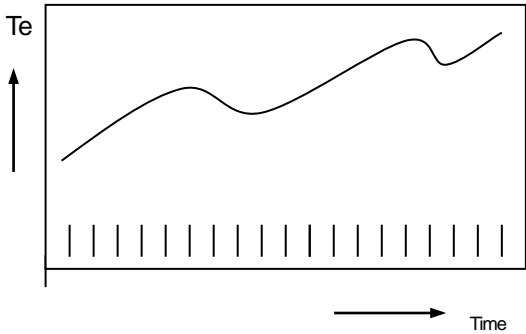

[Fig.1.1] Analog quantity

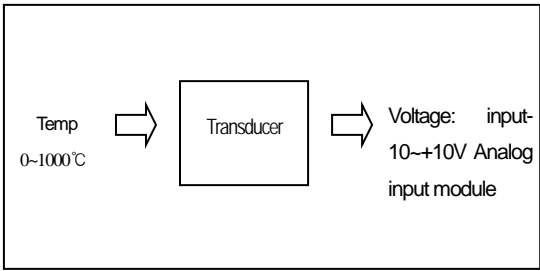

[Fig.1.2] An example of the transducer

1.2.1 Analog Quantity - A

Analog quantity refers to when a physical value is continuous. As analog values are unbroken, there is always a median value. Physical properties in general such as voltage, current, velocity, pressure and flow fall into the analog quantity. For example, the temperature is seamless over time as shown in Fig. 1.1, because the temperature cannot be input directly into the Analog input module, it needs to be relayed by a transducer that converts input signals of analog properties into electrical signals.

1.2.2 Digital Quantity - D

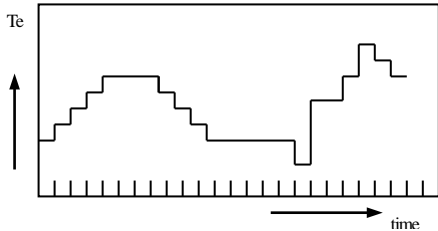

[Fig. 1.3] Digital quantity

The data consisting of integers or the physical properties in figures are referred to as digital properties (Fig. 1.3). The digital properties are the electronic method of creating, storing and processing the data in only 0 and 1. The data transmitted or stored by digital technology is expressed in a string of 0 and 1. For example, the on and off signals can be expressed in 0 and 1 digital values, and the BCD or binary values are also digital values.

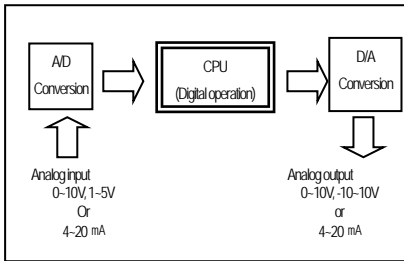

[Fig. 1.4] Process at PLC

Analog values cannot be directly input in the PLC CPU for an operation. That is why the analog values are converted in digital values when they are input in the PLC CPU as shown in Fig. 1.4. This is carried out by the Analog input module. In addition, for the analog values to be output to the outside, the PLC CPU digital values should be converted into analog values, this function is conducted by the Analog output module.

1.2.3. The Characteristics of Analog-Digital Conversion

(1) Voltage input

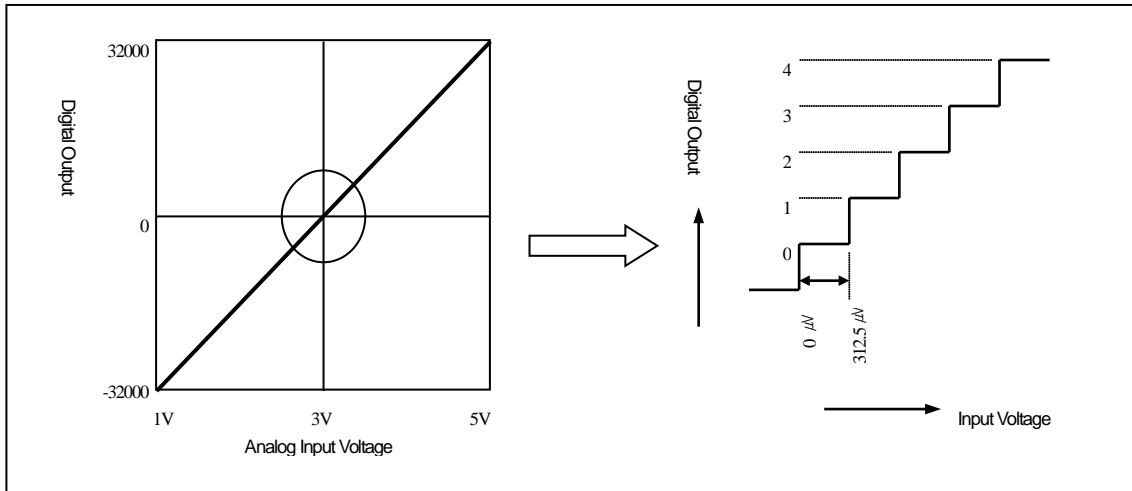

[Fig.1.5] A/D conversion characteristics (voltage input)

The Analog input module converts the analog electric signals that are input from an external device into digital values, which makes operations possible in the PLC CPU. When 1 ~ 5 V is used as the analog input range in the voltage Analog input module, the analog input quantity of 1V is digital value -32000, and that of 5V is digital value 32000. Therefore this case analog input 312.5 μV corresponds to digital value 1 (Fig. 1.5).

(2) Current input

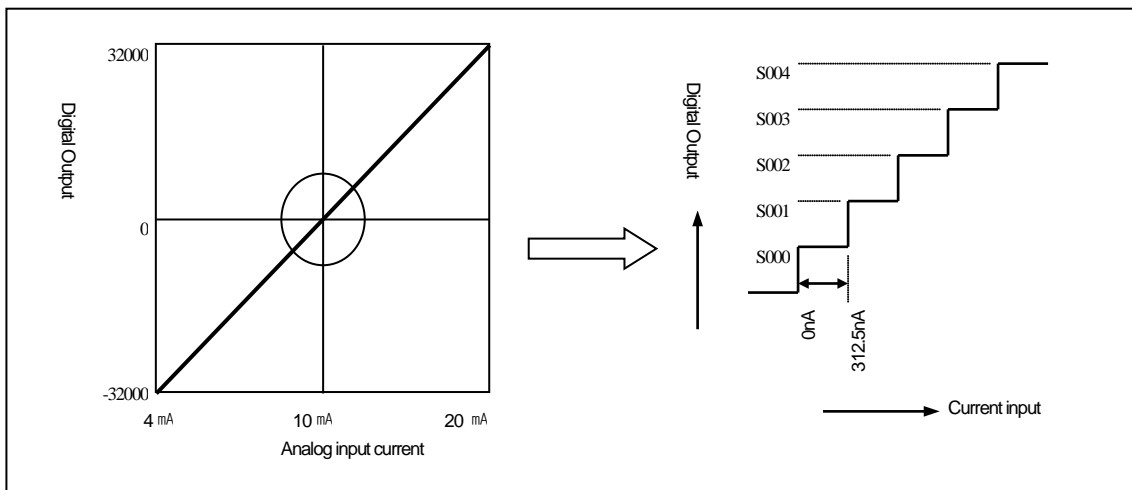

[Fig.1.6] A/D conversion characteristics (current input)

If 4 ~ 20 mA is used as the analog input range in a current Analog input module, the analog input value of 4 mA is output as digital value -32000, and the analog input value of 20mA is digital 32000. In this case, analog input 312.5 nA corresponds to digital value 1 (Fig. 1.6).

Chapter 2 Specification

2.1 General Specifications

Table 2.1 shows the general specifications of XGT series.

[Table 2.1] General specifications

No.	Item	Specifications	Related specifications		
1	Ambient temperature	0 ~ 55 °C	-		
2	Storage temperature	-25 ~ +70 °C	-		
3	Ambient humidity	5 ~ 95%RH (Non-condensing)	-		
4	Storage humidity	5 ~ 95%RH (Non-condensing)	-		
5	Vibration resistance	Occasional vibration		-	
		Frequency	Acceleration	Amplitude	How many times 10 times each directions (X, Y and Z)
		$5 \leq f < 8.4\text{Hz}$	-	3.5mm	
		$8.4 \leq f \leq 150\text{Hz}$	9.8 m/s^2 (1G)	-	
		For continuous vibration			
		Frequency	Acceleration	Amplitude	
		$5 \leq f < 8.4\text{Hz}$	-	1.75mm	
		$8.4 \leq f \leq 150\text{Hz}$	4.9 m/s^2 (0.5G)	-	
6	Shock resistance	<ul style="list-style-type: none"> Peak acceleration: 147 m/s^2(15G) Duration: 11ms Half-sine, 3 times each direction per each axis 	IEC61131-2		
7	Noise resistance	Square wave Impulse noise	AC: $\pm 1,500\text{V}$, DC: $\pm 900\text{V}$	LS ELECTRIC standard	
		Electrostatic discharge	Voltage : 4kV (contact discharging)	IEC 61131-2, IEC 61000-4-2	
		Radiated electromagnetic field noise	80 ~ 1,000 MHz, 10V/m	IEC 61131-2, IEC 61000-4-3	
		Fast transient /bust noise	Segment Voltage	Power supply module 2kV	Digital/analog input/output communication interface 1kV
8	Environment	Free from corrosive gasses and excessive dust	-		
9	Altitude	Up to 2,000 ms	-		
10	Pollution degree	Less than equal to 2	-		
11	Cooling	Air-cooling	-		

Note

(1) IEC (International Electrotechnical Commission):

An international nongovernmental organization which promotes internationally cooperated standardization in electric/electronic field, publishes international standards and manages applicable estimation system related with.

(2) Pollution degree:

An index indicating pollution degree of the operating environment which decides insulation performance of the devices. For instance, Pollution degree 2 indicates the state generally that only non-conductive pollution occurs. However, this state contains temporary conduction due to dew produced.

2.2 Performance Specifications

Table 2.2 shows the performance specifications of the 2-wire input analog input module.

[Table 2.2] Performance specifications

	Specifications										
	Current	Voltage									
Number of channel	4 channels										
Analog input range	DC 4 ~ 20 mA (input resistance 250 Ω)	DC 1 ~ 5 V (input resistance: 1 MΩ min.)									
Transmitter power supply	Supply voltage	24V DC ± 15%									
	Maximum supply current	30 mA									
	Short circuit protection	Yes (current limit: 25~35 mA)									
Digital output	(1) Current										
	<table border="1"> <tr> <td>Analog input</td> <td>4 ~ 20 mA</td> </tr> <tr> <td>Digital output</td> <td></td> </tr> <tr> <td>Signed value</td> <td>-32000 ~ 32000</td> </tr> <tr> <td>Precise value</td> <td>4000 ~ 20000</td> </tr> <tr> <td>Percentile value</td> <td>0 ~ 10000</td> </tr> </table>		Analog input	4 ~ 20 mA	Digital output		Signed value	-32000 ~ 32000	Precise value	4000 ~ 20000	Percentile value
Analog input	4 ~ 20 mA										
Digital output											
Signed value	-32000 ~ 32000										
Precise value	4000 ~ 20000										
Percentile value	0 ~ 10000										
Digital output	(2) Voltage										
	<table border="1"> <tr> <td>Analog input</td> <td>1 ~ 5 V</td> </tr> <tr> <td>Digital output</td> <td></td> </tr> <tr> <td>Signed value</td> <td>-32000 ~ 32000</td> </tr> <tr> <td>Precise value</td> <td>1000 ~ 5000</td> </tr> <tr> <td>Percentile value</td> <td>0 ~ 10000</td> </tr> </table>		Analog input	1 ~ 5 V	Digital output		Signed value	-32000 ~ 32000	Precise value	1000 ~ 5000	Percentile value
Analog input	1 ~ 5 V										
Digital output											
Signed value	-32000 ~ 32000										
Precise value	1000 ~ 5000										
Percentile value	0 ~ 10000										
The digital output data format can be set through the user program or the [I/O parameter] of XG5000 for each channel.											
Maximum resolution	1 / 64000										
Precision	Reference precision is below: ±0.05% (room temperature, 25°C) Temperature factor: ±70 ppm/°C (0.007% /°C)										
Maximum conversion speed	10 ms/4 channels										
Absolute maximum input	±30 mA	±6 V									
Analog input	4 channels/1 module										
Insulation		Insulation	Insulation voltage	Insulation resistance							
	Inter-channel	Transformer	500 V AC, 50/60 Hz, leakage current per minute less than 10 mA	Over 500 V DC, 10 MΩ							
	Btw input terminal and PLC power supply	Photo coupler									
External power supply	24VDC + 20%, -15%										
Access terminal	18 point terminal block										
Input and output occupancy point	Fixed type: 64, adjustable type: 16 points										
Current consumption	Inside	DC 5V : 180 mA									
	Outside	DC 24V : 480 mA									
Weight	145 g										

Note

- (1) The 2-wire input type analog input module has the offset and gain values set for each analog input range when it is manufactured. The user cannot change the values.
- (2) Offset value: the analog input value of which the digital output value is -32000 when the digital output type is set as an unsigned value
- (3) Gain value: the analog input value of which the digital output value is 32000 when the digital output type is set as an unsigned value

2.3 Description of the Parts

This section is about the name of each part.

2.3.1 XGF-AW4S

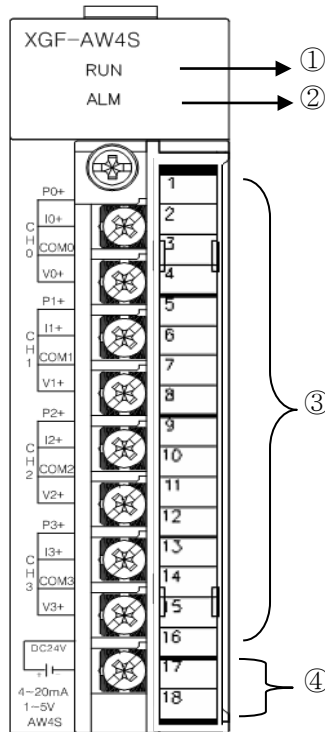

No.	Name and description
①	<p>RUN LED</p> <ul style="list-style-type: none"> ▶ Displays the operating status of XGF-AW4S On: operating normally Flickering: error (for details, see 7.1) Off: DC 5V disconnection, XGF-AW4S module failure
②	<p>ALM LED</p> <ul style="list-style-type: none"> ▶ Alarm of XGF-AW4S On: alarm detection (process alarm, change rate alarm) Off: operates within the set alarm value range Flickering: Disconnection detection (However, when using process alarm or change rate alarm, disconnection detection and display through LED is not displayed)
③	<p>Terminal block</p> <ul style="list-style-type: none"> ▶ The terminal block connected to an external device for each channel for analog value current/voltage to be input
④	<p>External 24V terminal block</p> <ul style="list-style-type: none"> ▶ External 24V supply terminal block

2.4 Characteristics of Input/Output Conversion

The characteristics of input/output conversion is the slope of the straight line connecting the offset and the gain values when the analog signals (current or voltage input) from the PLC external device into digital values.
 Below are the characteristics of input/output conversion of the 2-wire input type analog input module.

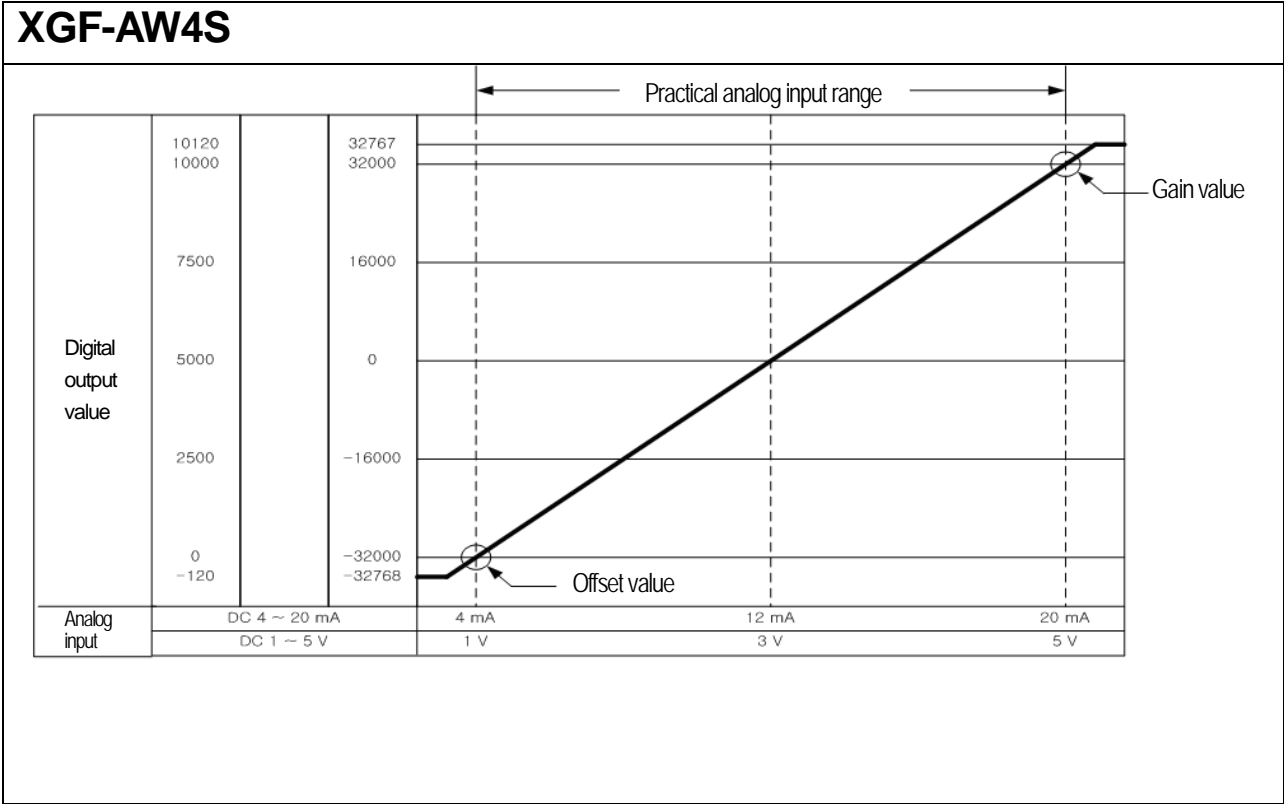

2.4.1 Characteristics of Input/Output

Being a 4 channel 2-wire input type analog input module, the offset/gain of XGF-AW4S cannot be set by the user. The voltage/current input range can be set for each channel by using the user program or [I/O parameter]. The output type of the digital data is defined as follows.

- (a) Signed Value
- (b) Precise Value
- (c) Percentile Value

In the range of DC 4 ~ 20 mA

(1) Set [Input range] at 4 ~ 20 mA in [I/O parameter] of XG5000.

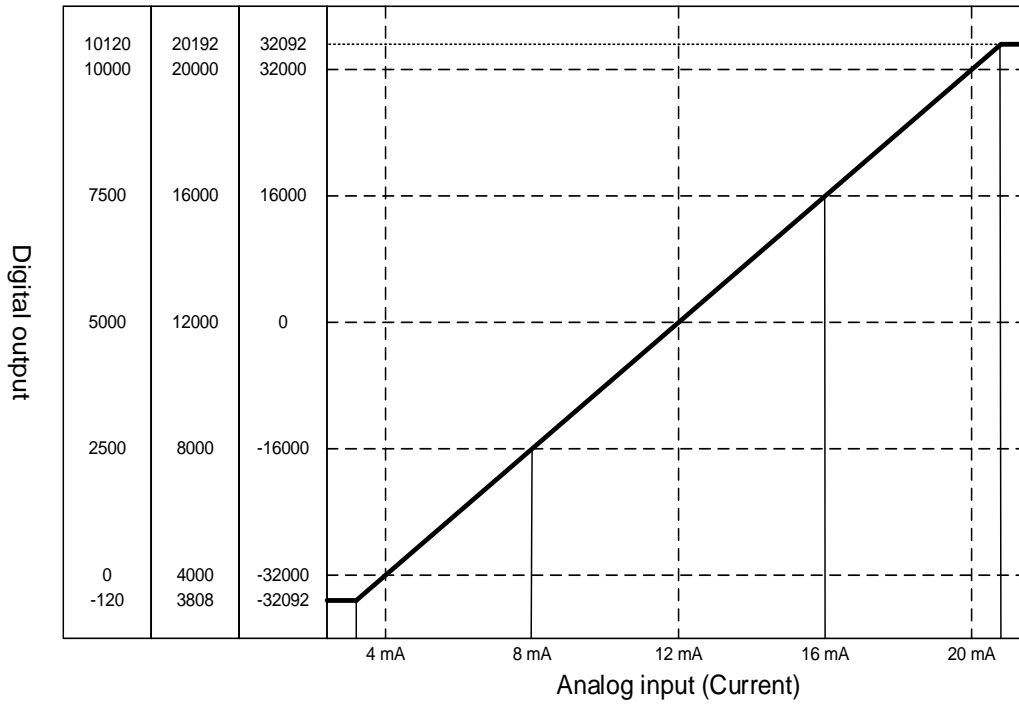
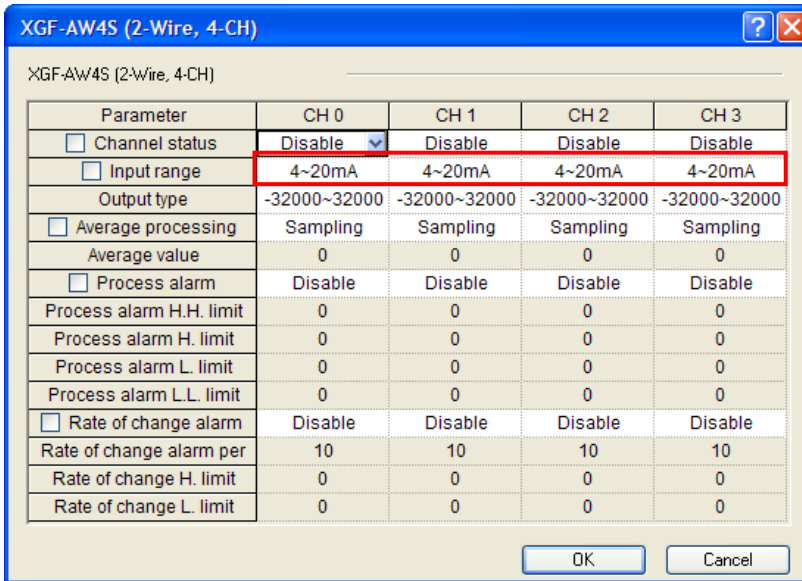

- ▶ The digital output values for the current input characteristics are as follows.
(Resolution (for 1/16000): 250 μ A)

Digital output range	Analog input current (mA)						
	3.808	4	8	12	16	20	20.192
Signed value (-32768 ~ 32767)	-32092	-32000	-16000	0	16000	32000	32092
Precise value (3808 ~ 20192)	3808	4000	8000	12000	16000	20000	20192
Percentile value (-120 ~ 10120)	-120	0	2500	5000	7500	10000	10120

In the range of DC 1 ~ 5 V

- (2) Set [Input range] at 1 ~ 5 V in [I/O parameter] of XG5000.

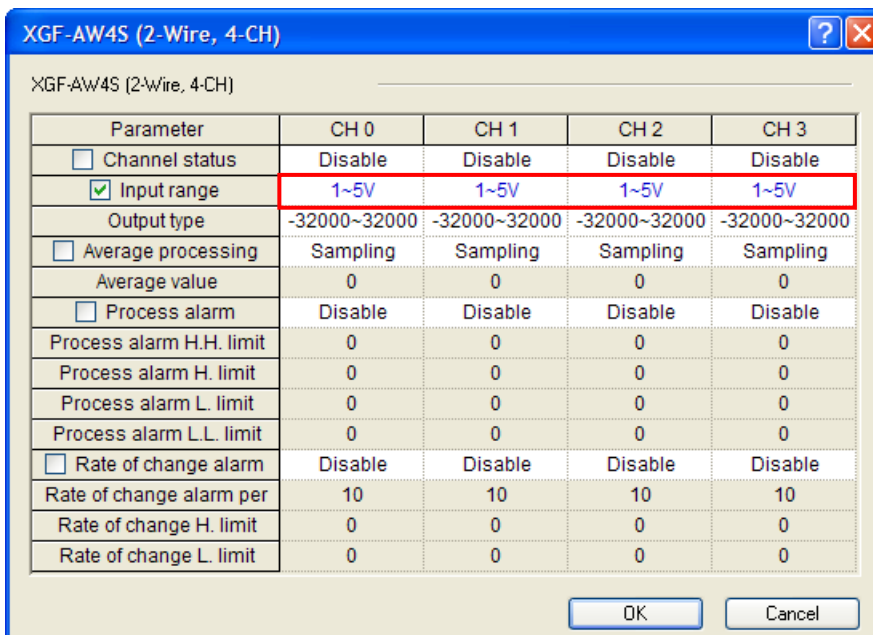

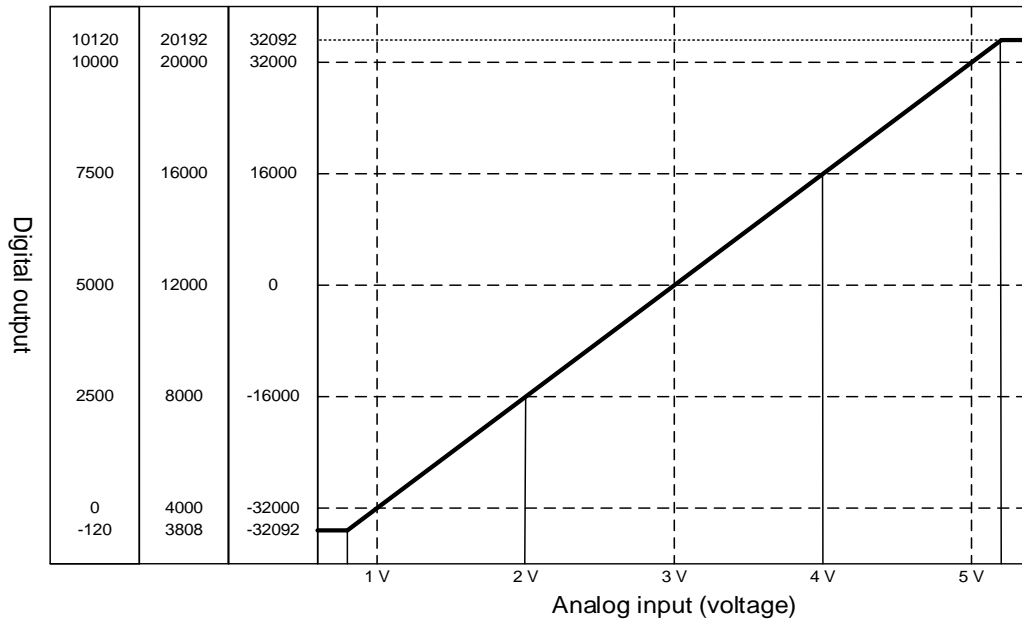

► The digital output values for the current input characteristics are as follows. (resolution (for 1/64000): 62.5 μ V)

Digital output range	Analog input voltage (V)						
	0.952	1	2	3	4	5	5.048
Signed value (-32768 ~ 32767)	-32092	-32000	-16000	0	16000	32000	32092
Precise value (952 ~ 5048)	952	1000	2000	3000	4000	5000	5048
Percentile value (-120 ~ 10120)	-120	0	2500	5000	7500	10000	10120

Note

- (1) When a value out of the digital output range is input as the analog input value, the digital output value is maintained as the maximum or the minimum value that fall within the set output range. For example, when the digital output range is set as the signed value (-32768 ~ 32767), and an analog value that exceed 32767 or -32768 is entered as the digital output value, the digital output value is fixed at 32767 or -32768.
- (2) Do not set the current and voltage out of ± 30 mA and ± 6 V respectively. It might cause a failure due to the heat.
- (3) Offset/gain setting of XGF-AW4S cannot be done by the user.

2.4.2 Precision

The precision for the digital output value does not change if the input range is changed. Fig 2.1 shows the range of precision at surrounding temperatures of 25 when the analog input range and digital output type are set at 1 ~ 5 V and signed value respectively. The precision is $\pm 0.05\%$ when the temperature is 25 and the temperature factor is $70 \text{ ppm}/^\circ\text{C}$.

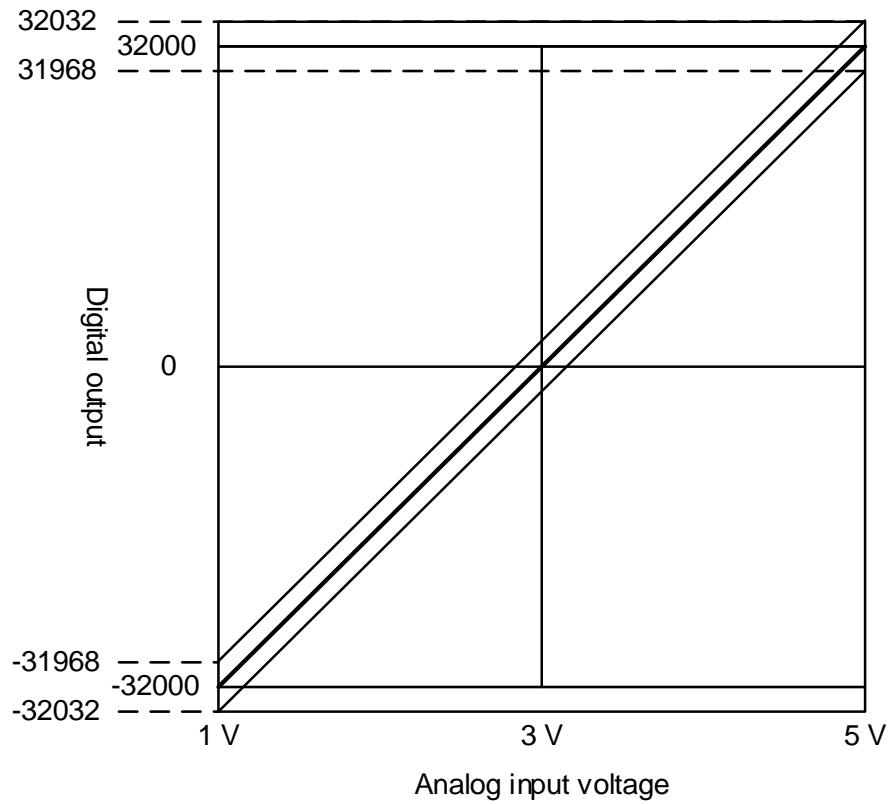

[Fig. 2.1] Precision

2.5 Functions of the Analog Input Module

[Table 2.3] explains the functions of the analog conversion module.

[Table 2.3] List of functions

Functions	Description
Set channel operating/stop	Sets the operating/stop of the channel to conduct A/D conversion.
Set input voltage/current ranges	Sets the analog input range you want to use. The ranges of current and voltage are 4~20 mA and 1~5V respectively.
Set the output data type	(1) Sets the digital output type. (2) 3 output data types are provided in this module.
A/D conversions type	(1) Sampling processing Sampling processing when no A/D conversion method is specified (2) Average processing (a) Time processing Outputs the average of the A/D conversion value for the set period of time (b) Count average Outputs the average of the A/D conversion value the set number of times (c) Moving average Outputs the average of the A/D conversion value in the sampling sequence the set number of times (d) Weighted average Slows a sudden change of the input A/D conversion value
Alarm	(1) Process alarm Switches on the process alarm flag at values less or more than the set process alarm value. (2) Change rate alarm Sets the A/D conversion sampling cycle and detects the change rate
Detection of an input disconnection	(1) When there is a short circuit of the analog inputs that have ranges of 4 ~ 20 mA and 1 ~ 5 V, it can be detected in the user program.
Power supply ON/OFF	(1) Can switch on/off the transmitter power supply for each channel. (2) On and off when the channel is running or stops respectively.

2.5.1 Average Processing

The A/D conversion of a designated channel is conducted a set times or for a set time and the average of the sum is stored in the memory. Whether to conduct average processing and the time and number of times can be set for each channel by setting the user program or [I/O parameter].

(1) Why is average processing used?

Abnormal analog input signals such as noise can be A/D converted to a value close to a normal analog input signal.

(2) Types of average processing

Average processing divides into time, number and weighted averages.

(a) Time average processing

- 1) Settable range: 20 ~ 5000(ms)
- 2) The number of average processing processes is the set time/10 (times)

E.g.) when the time is set at 68ms

$$\text{Number of average processing} = \frac{68 \text{ ms}}{10 \text{ ms}} = 6.8 \text{ times}$$

In this case, the numbers below the decimal point are dropped. Therefore it is averaged to 6 times.

- *1: If the time is set below 20, it is processed to 20 and if over 5000, it is processed to 5000.
- *2: If the average time is not set within 20~5000, RUN LED flashes every second. If you want to turn RUN LED On, reset the average time within 20~5000 and turn PLC CPU from STOP to RUN. If you want to end the error through modification, you must use the clear request flag (UXY.11.0).
- *3: In case of an error of the number average value setting, the set value is saved as 20, which is the initial value

- 3) The time average is converted into number average within the Analog input module. There can be a remainder after the set time is converted into the number of times. The remainder is dropped and the average number of processing is (set time)/(conversion speed).

E.g.) When the time is set at 151ms,

$$151 \text{ ms} \div (10 \text{ ms}) = 15.1 \text{ times} \dots\dots \text{remainder } 1 \rightarrow 15 \text{ times}$$

(b) Number average processing

- 1) Settable range: 2 ~ 500 (times)
- 2) When you use the number average, the time it takes for the average value to be saved in the memory differs according to the number of the channels being used

$$\text{The processing time} = \text{the set number of times} \times 10(\text{ms})$$

E.g.) When the number of times of average processing is 50,

$$50 \times (10 \text{ ms}) = 500 \text{ ms}$$

- *1: If the number average is set below 2, it is processed to 2 and if over 500, it is processed to 500
- *2: If the average time is not set within 2~500, RUN LED flashes every second. If you want to turn RUN LED On, reset the average time within 2~500 and turn PLC CPU from STOP to RUN. If you want to end the error through modification, you must use the clear request flag (UXY.11.0).
- *3: In case of an error of the number average value setting, the set value is saved as the initial value.

(c) Moving average processing

- 1) Settable range: 2~100 (times)
- 2) The sampled A/D conversion value is saved in the memory as many times as the number of time set within the settable range. The average of the following stored data will be calculated. Every time the most recently sampled A/D conversion

values enter the memory, the oldest sampled A/D conversion data is dropped one after another with the new average calculated each time. Fig. 7.2 shows an example when the moving average processing is set at 4.

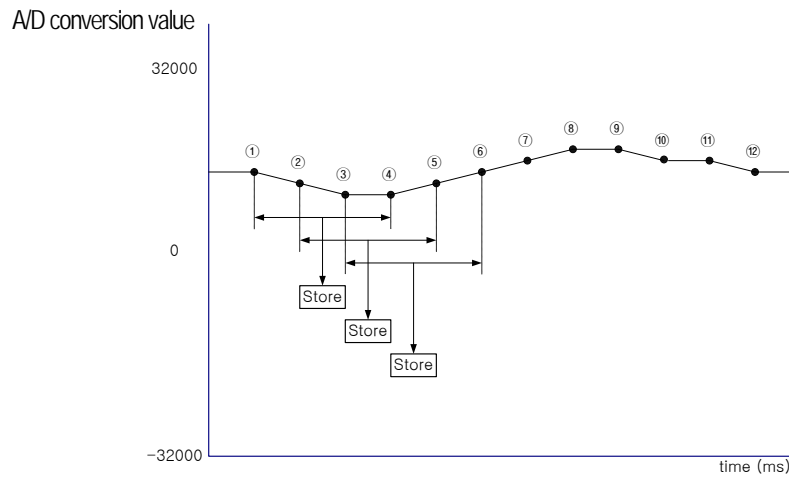

[Fig. 7.2] Moving average

$$\text{Store 1} = (\textcircled{1} + \textcircled{2} + \textcircled{3} + \textcircled{4}) / 4$$

$$\text{Store 2} = (\textcircled{2} + \textcircled{3} + \textcircled{4} + \textcircled{5}) / 4$$

$$\text{Store 3} = (\textcircled{3} + \textcircled{4} + \textcircled{5} + \textcircled{6}) / 4$$

(d) Weighted average processing

Weighted average processing is for getting stable digital output values by filtering sudden changes of the noise or input values. The weighted average constant can be set for each channel by setting the user program or I/O parameter.

1) Settable range: 1 ~ 99(%)

$$F[n] = (1 - \alpha) \times A[n] + \alpha \times F[n - 1]$$

$F[n]$: the current weighted average output value
 $A[n]$: the current A/D conversion value
 $F[n-1]$: the previous weighted average output value
 α : weighted average constant (0.01 ~ 0.99: weighted value of the previous value)

*1: If the weighted average is set below 1, it is processed as 1 and if over 99, processed as 99.

*2: If you do not set the time average within 1~99, RUN LED flashes every second. If you want to keep RUN LED on, reset the time average within 4 ~ 16000 and switch the operating mode of the CPU module from STOP to RUN. If you want to end the error through modification, you must use the clear request flag (UXY.11.0).

*3: In case of an error of the number average value setting, the set value is saved as 1, which is the initial value.

2) Voltage input

- The analog input range is set at DC 1 ~ 5 V and the digital output range is set at -32000 ~ 32000.
- When the analog input value changes 1 V → 5 V (-32000 → 32000), the weighted average output value according to α is as follows

α value	Weighted average output value				Note
		1 scan	2 scans	3 scans	
*1) 0.01	0	31360	31993	31999	1% biased toward previous value
*2) 0.5	0	0	16000	24000	50% biased toward previous value
*3) 0.99	0	-31360	-30726	-30099	99% biased toward previous value

*1) 32000 output after about 4 scans

*2) 32000 output after about 24 scans

*3) 32000 output after about 1629 scans (16.29 s)

3) Current input

- The analog input range is set at DC 4 ~ 20 mA and the digital output range is set at -32000 ~ 32000.
- When the analog input value changes 4mA → 12 mA (-32000 → 16000), the weighted average output value according to α is as follows.

α value	Weighted average output value				Note
		1 scan	2 scans	3 scans	
*1) 0.01	0	15520	15995	15999	1% biased toward previous value
*2) 0.5	0	-8000	4000	10000	50% biased toward previous value
*3) 0.99	0	-31520	-31044	-30574	99% biased toward previous value

*1) 16000 output after about 4 scans

*2) 16000 output after about 24 scans

*3) 16000 output after 1600 scans (16 s)

- If you do not use the weighted average processing, the current A/D conversion value is directly output. Weighted processing is getting data by putting a weighted value between the current and the previous A/D conversion values, and the weighted value can be decided by the average value. If there is much wavering of the output data, set the average value high.

2.5.2 Alarm Function

(1) Process alarm

If the digital output value is greater than the process alarm further upper limit or smaller than the process alarm further lower limit, switch on the alarm flag and the alarm LED. If the digital output value is greater than the process alarm further upper limit and smaller than the process alarm upper limit, the alarm ends. And if the digital output value is smaller than the process alarm further lower limit or greater than the process alarm further lower limit, the alarm also ended.

(2) Change rate alarm

The A/D conversion value is sampled in the cycle set as 'Change rate detection cycle.' The (N-1)th sampled A/D conversion value and the Nth one are compared. The unit of the values set as the upper and lower limits of the change rate alarm is %/s.

(a) The setting range of the change rate alarm detection cycle

The setting range of the change rate alarm detection cycle is 10 ~ 5000(ms). When the change rate detection cycle is set at 1000, the A/D conversion value is detected every second for comparison of the change rates.

(b) The setting range of the upper and lower limits of the change rate alarm

The setting range of the upper and lower limits of the change rate alarm is -32768 ~ 32767(-3276.8%/s ~ 3276.7%/s).

(c) The cut-off value per change rate alarm detection cycle

The cut-off value per change rate alarm detection cycle = the upper or lower limits of the change rate alarm X 0.001 X 64000 X change rate alarm detection cycle ÷ 1000

(d) Example of change rate setting 1 (detection of the increase rate)

- 1) The change rate alarm detection cycle of channel 0: 10(ms)
- 2) The upper limit of the change rate alarm of channel 0: 100(10.0%)
- 3) The lower limit of the change rate alarm of channel 0: 90(9.0%)
- 4) The cut-off value per change rate alarm detection cycle against the upper limit of the change rate alarm of channel 0 = $100 \times 0.001 \times 64000 \times 10 \div 1000 = 64(\text{digit})$
- 5) The cut-off value per change rate alarm detection cycle against the lower limit of the change rate alarm of channel 0 = $90 \times 0.001 \times 64000 \times 10 \div 1000 = 57.6 = 57(\text{digit})$
- 6) If ([n]th A/D conversion value) – ([n-1]th A/D conversion) is greater than 64 digits, the change rate detection upper flag of channel 0 (CH0 H) is On.
- 7) If ([n]th A/D conversion value) – ([n-1]th A/D conversion) is greater than 57 digits, the change rate detection lower flag of channel 0 (CH0 H) is On.

(e) Example of change rate setting 2 (detection of the decrease rate)

- 1) The change rate alarm detection cycle of channel 0: 100(ms)
- 2) The upper limit of the change rate alarm of channel 0: -10 (-1.0%)
- 3) The lower limit of the change rate alarm of channel 0: -20 (-2.0%)
- 4) The cut-off value per change rate alarm detection cycle against the upper limit of the change rate alarm of channel 0 = $-10 \times 0.001 \times 64000 \times 100 \div 1000 = -64(\text{digit})$
- 5) The cut-off value per change rate alarm detection cycle against the lower limit of the change rate alarm of channel 0 = $-20 \times 0.001 \times 64000 \times 100 \div 1000 = -128(\text{digit})$
- 6) If ([n]th A/D conversion value) – ([n-1]th A/D conversion) is greater than -64 digits, the change rate detection upper flag of channel 0 (CH0 H) is On.
- 7) If ([n]th A/D conversion value) – ([n-1]th A/D conversion) is greater than -128 digits, the change rate detection lower flag of channel 0 (CH0 H) is On.

(f) Example of change rate setting 3 (detection of change rate)

- 1) The change rate alarm detection cycle of channel 0: 1000(ms)
- 2) The upper limit of the change rate alarm of channel 0: 2(0.2%)
- 3) The lower limit of the change rate alarm of channel 0: -2(-0.2%)
- 4) The cut-off value per change rate alarm detection cycle against the upper limit of the change rate alarm of channel 0 = 2
 $X 0.001 \times 64000 \times 1000 \div 1000 = 128(\text{digit})$
- 5) The cut-off value per change rate alarm detection cycle against the lower limit of the change rate alarm of channel 0 = -2
 $X 0.001 \times 64000 \times 1000 \div 1000 = -128(\text{digit})$
- 6) If ([n]th A/D conversion value) – ([n-1]th A/D conversion) is greater than 128 digits, the change rate detection upper flag of channel 0 (CH0 H) is On
- 7) If ([n]th A/D conversion value) – ([n-1]th A/D conversion) is greater than -128 digits, the change rate detection lower flag of channel 0 (CH0 H) is On

2.5.3 Input Disconnection Detection

(1) Settable range

You can detect disconnection of the input circuit when you use the input signal range of 4 ~ 20 mA, 1 ~ 5 V. The conditions for detection of each input signal range is as shown in the table below.

Input signal range	Current/voltage values perceived as disconnection
4 ~ 20 mA	Below 0.8 mA
1 ~ 5 V	Below 0.2 V

(2) Display of disconnection by channel

The disconnection detection signal for each input channel is saved in UXY.10. (X represents the base number and Y the slot number)

Bit	15	14	13	12	11	10	9	8	7	6	5	4	3	2	1	0
Initial value	0	0	0	0	0	0	0	0	0	0	0	0	0	0	0	0
Allocate	-	-	-	-	-	-	-	-	-	-	-	-	CH 3	CH 2	CH 1	CH 0

BIT	Description
0	Normal
1	Disconnected

(3) Action

Each bit is set as 1 when a disconnection is detected of an allocated channel, and recovers to 0 when the disconnection is restored. Each bit can be used for detecting disconnection in the user program as shown in the table of conditions above.

(4) An example of the program

If a module is mounted in base 0, slot 1, below is an example of using the disconnection detection flag. If a disconnection is detected of the channel, the detected channel number is written in the P area.

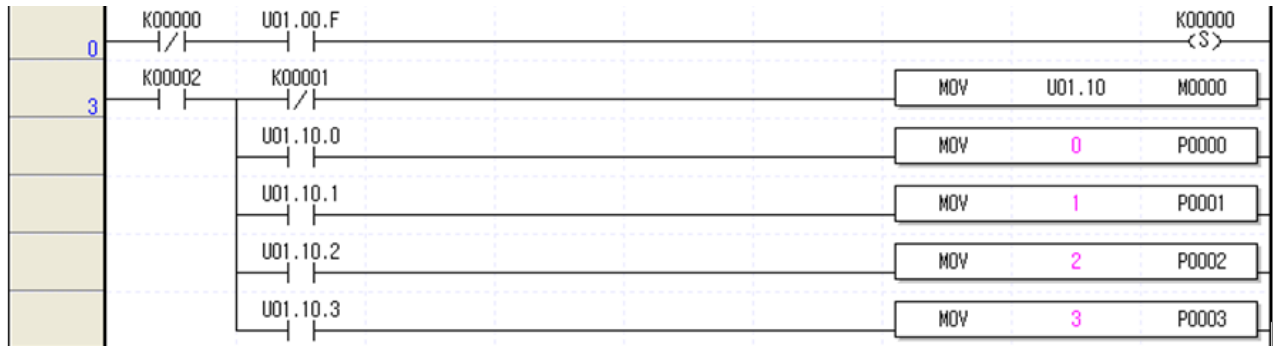

Note

- (1) If it is used wired with a transmitter, you need the time for stabilizing the transmitter outputs and warm-up of the transmitter. If you don't count the time, the precision might not be met.
- (2) Precision of XGF-AW4S is affected by that of transmitter.

Chapter 3 Installation and Wiring

3.1 Installation

3.1.1 Installation Environment

Although this device has high reliability regardless of the environment where it is mounted, pay attention to the following conditions for reliability and stability of the system.

- (1) Environment conditions
 - (a) Mount on a water-proof and vibration proof controlling board.
 - (b) Where there are no continuous shocks or vibrations
 - (c) Where there is no direct sunlight
 - (d) Where there is no condensation caused by sudden changes of the temperature
 - (e) Where the temperature remains between 0-55°C
- (2) Installation work
 - (a) Do not leave wiring remnants in the PLC when boring screws holes or doing wiring work.
 - (b) Install in a place where you can easily manipulate it.
 - (c) Do not install with a high voltage device in the same panel
 - (d) Keep at least 50mm from a duct or module.
 - (e) Connect to ground where the noise environment is good.

3.1.2 Precautions in Handling

This section provides information on the precautions in from opening to installing the XGF-AW4S module.

- (1) Do not drop or hit hard.
- (2) Do not separate the PCB from the case. It may cause a failure.
- (3) Be careful not to let foreign substances such as the wiring remnants in the upper part of the module when doing the wiring work.
- (4) Do not mount or dismount when the power is on.
- (5) You can't use compression terminal with Sleeve. Proper compression terminal to connect terminal block is as follows.



- (6) For cable connecting terminal block, use stranded wire 0.3~0.75mm², diameter 2.8mm or below. Allowable current may be different according to insulation thickness.
- (7) For torque of screw, refer to the following table.

Screw	Torque range
Screw in terminal block (M3 screw)	42 ~ 58 N.cm
Screw for fixing terminal block (M3 screw)	66 ~ 89 N.cm

Notes

- (1) For XGR system, XGF-AW4S can be used in expansion base. Namely, it can't be used in main base.

3.2 Wiring

3.2.1 Precautions in Wiring

- (1) Do not put an AC power supply line near an external input signal line of an analog input module. Keep them apart enough not to be affected by the surge or induced noise from the AC side.
- (2) Consider the surrounding temperature and allowed current when choosing the cable. A cable should be larger in maximum diameter than AWG22(0.3mm²).
- (3) If the cable is placed too close to a hot device or material or put in direct contact with oil, for example, it may cause a short circuit and result in damage or malfunction.
- (4) Check the polarity when wiring the terminal block.
- (5) When cables are wired with high voltage lines or power supply cords, an induction failure may occur resulting in malfunction or a failure.

3.2.2 Example of Wiring

Channel	Polarity	Terminal no.
CH0	P0+	1
	I0+	2
	COM0	3
	V0+	4
CH1	P1+	5
	I1+	6
	COM1	7
	V1+	8
CH2	P2+	9
	I2+	10
	COM2	11
	V2+	12
CH3	P3+	13
	I3+	14
	COM3	15
	V3+	16
DC24V	DC 24V+	17
	DV 24V-	18

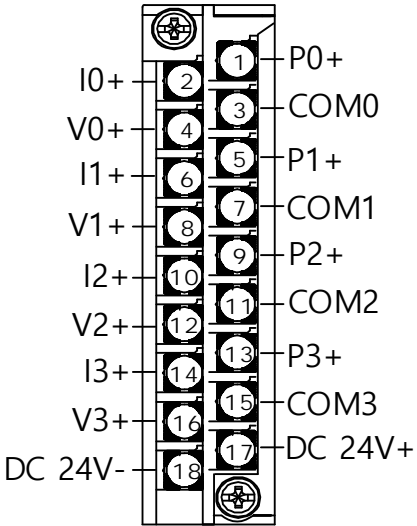

(1) 2-Wire sensor/transmitter wiring (current inputs)

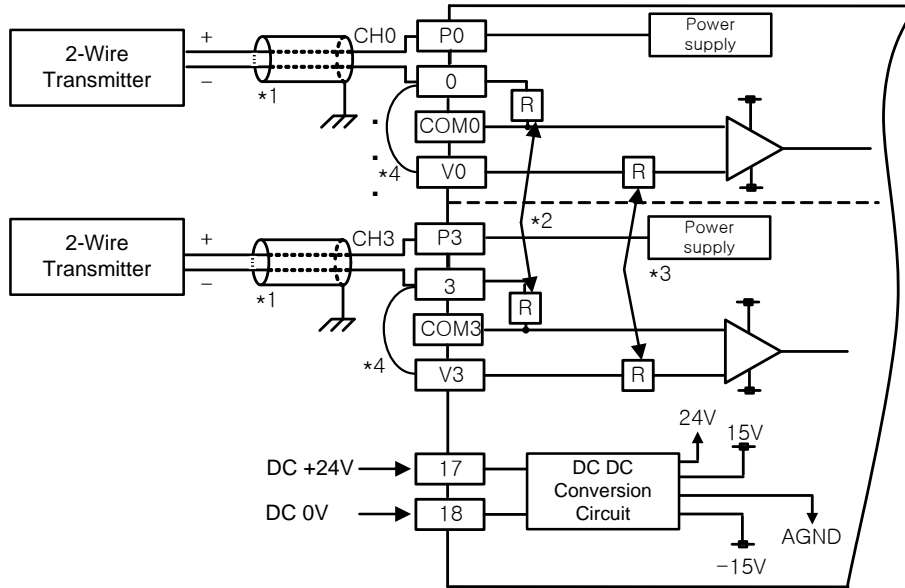

- (a) Set only the channel you are using at channel operation.
- (b) The XGF-AW4S module supplies power for input devices such as the transmitter.

(2) Example of 4-Wire sensor/transmitter wiring (current inputs)

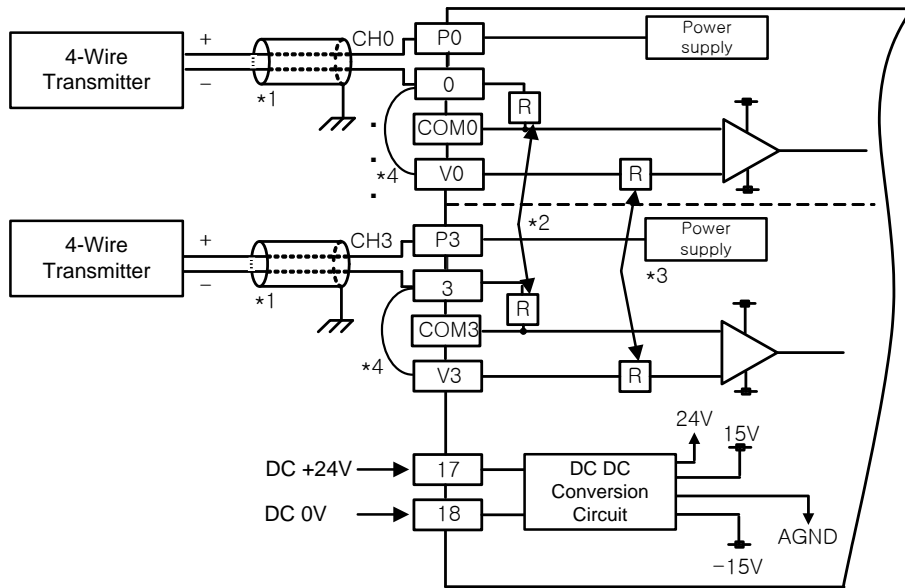

- (a) Set only the channel you are using at channel operation.
- (b) The XGF-AW4S module supplies power for input devices such as the transmitter.

- *1) Use 2 core twist shield cable. AWG 22 is recommended for the size of the cable.
- *2) 250 Ω (typ.) as the current input resistance of the analog input module.
- *3) 1 MΩ (min.) as the voltage input resistance of the analog input module.
- *4) In case of current input, connect V terminal to I terminal.

(3) Current inputs

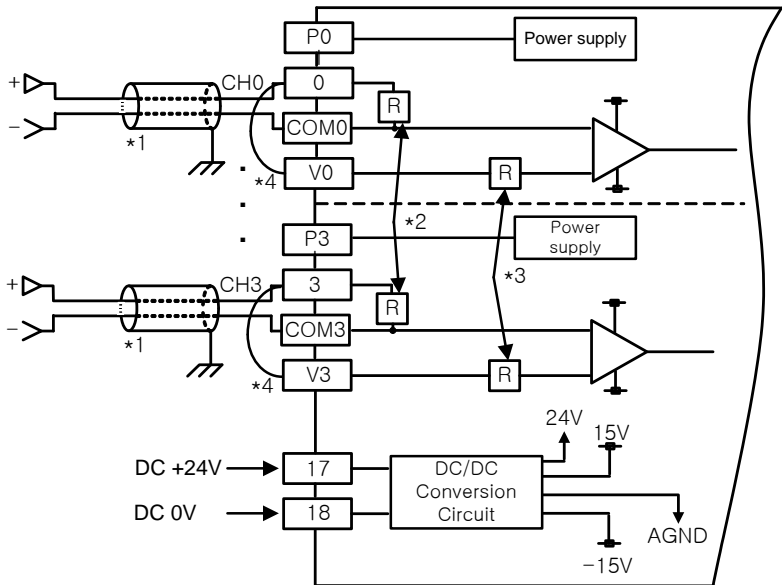

(4) Voltage inputs

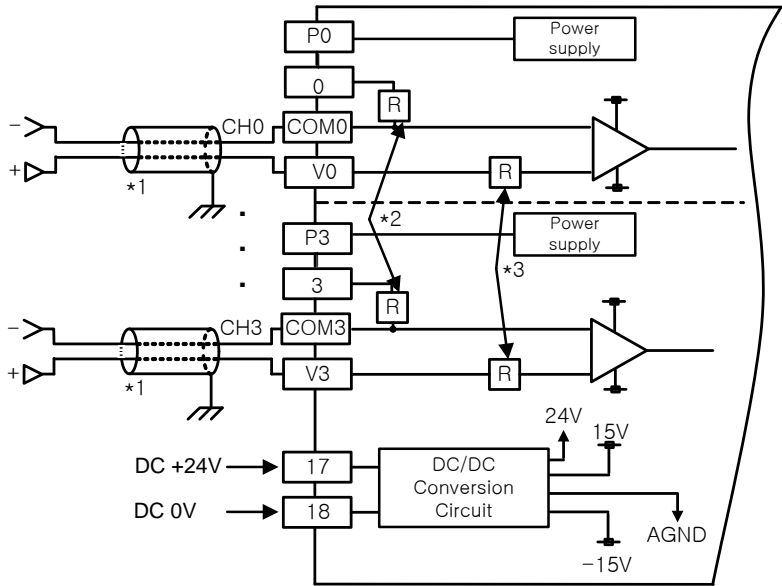

- *1) Use 2 core twist shield cable. AWG 22 is recommended for the size of the cable.
- *2) 250 Ω (typ.) as the current input resistance of the analog input module.
- *3) 1 MΩ (min.) as the voltage input resistance of the analog input module.
- *4) In case of current input, connect V terminal to I terminal.

(5) The relation between the voltage input precision and wiring length

The wiring length between the transmitter or sensor and the module in voltage inputs affect the digital conversion values of the module as shown below.

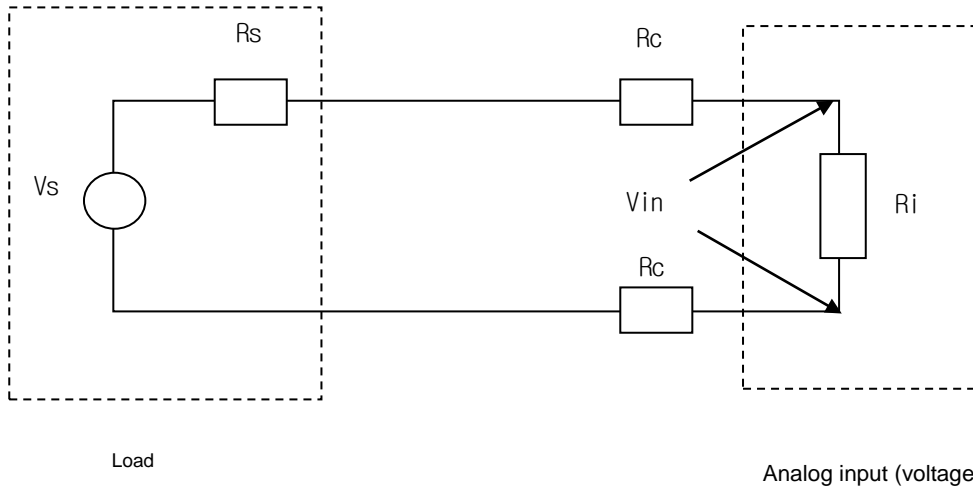

In the figure,

V_s : the analog output of the transmitter or sensor

R_c : the loop resistance of the cable

R_s : the internal resistance of the transmitter or sensor

R_i : the internal resistance of the module ($1M\Omega$) when the voltage is input

V_{in} : the voltage supplied to the analog input module

% V_i : the error (%) of the conversion values resulting from the source and cable lengths in voltage inputs

$$V_{in} = \frac{R_i \times V_s}{[R_s + (2 \times R_c) + R_i]}$$

$$\% V_i = \left(1 - \frac{V_{in}}{V_s}\right) \times 100\%$$

Note

There is no precision error from the cable length and the internal resistance of the source in current inputs.

Chapter 4 Operating Setting

4.1 The Operating Setting Flowchart

Fig. 4.1 illustrates the operating setting flowchart.

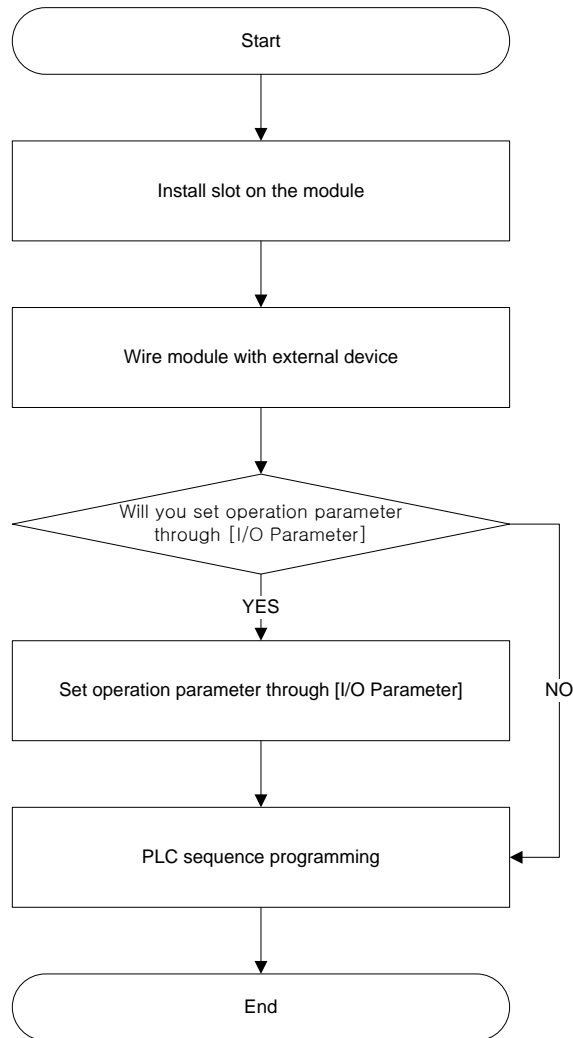

[Fig. 4. 1] Operating setting flowchart

4.2 Operating Parameter Setting

The operating parameters of the analog input module can be set in [I/O parameter] of XG 5000.

You can set the operating parameters of the 2-wire input analog input module through [I/O parameter] of XG5000.

4.2.1 Setting Items

XG5000 provides GUI (Graphical User Interface) type parameter setting of the analog input module in order to enhance the user's convenience. Table 4.1 shows the items that can be set through [I/O parameter] in the project window of XG5000.

[Table 4. 1] Functions of [I/O parameter]

	Description
[I/O parameter]	<p>(1) The following items are set that are necessary for operating the module.</p> <ul style="list-style-type: none"> - channel run/stop - analog input range - digital output data type - average processing method - average value - allow/block process alarm - further upper/upper/lower/further lower/ limits of process alarm - allow/block change rate alarm - cycle of detecting change rate - upper/lower limit of change rate alarm <p>(2) The data set by the user in [I/O parameter] is stored in the analog input module when [special module parameter] is downloaded. That is, when [special module parameter] is stored in the analog input module is not related to the RUN or STOP of PLC CPU.</p>

4.2.2 How to Use [I/O parameter]

This section provides information on how to use [I/O parameter].

- (1) Start XG5000 and create a project.
(For how to create a project, see the program manual of XG5000)
- (2) Double-click on [I/O parameter] in the project window.

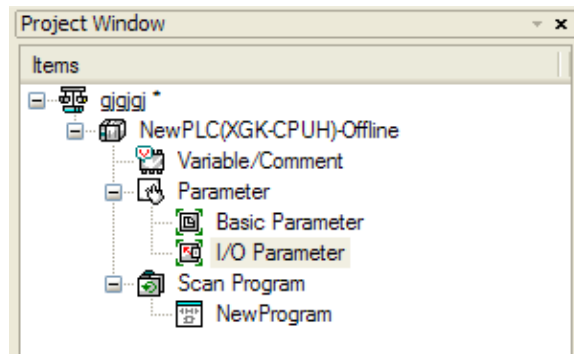

- (3) Click on the slot of the base where the module is mounted in the [set I/O parameter] window. In this illustration is the 2 wire input analog input module mounted in slot 4, base 0.

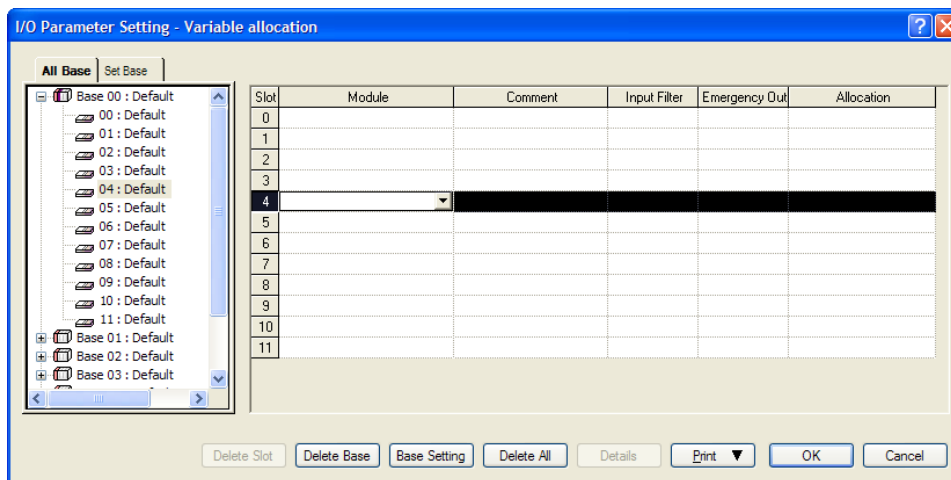

- (4) Click on the arrow button and then a window will appear where you can choose a desired module. Find and choose a desired module.

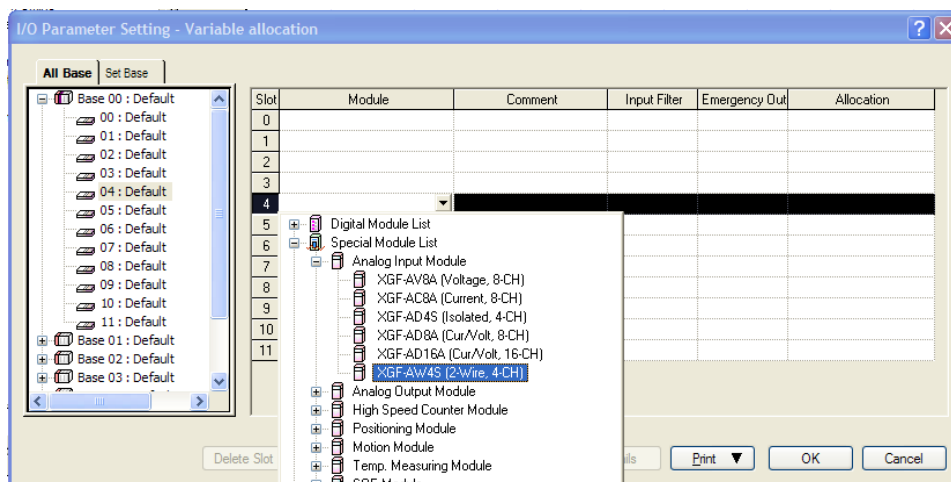

(5) Click on [Detail] button with the module chosen.

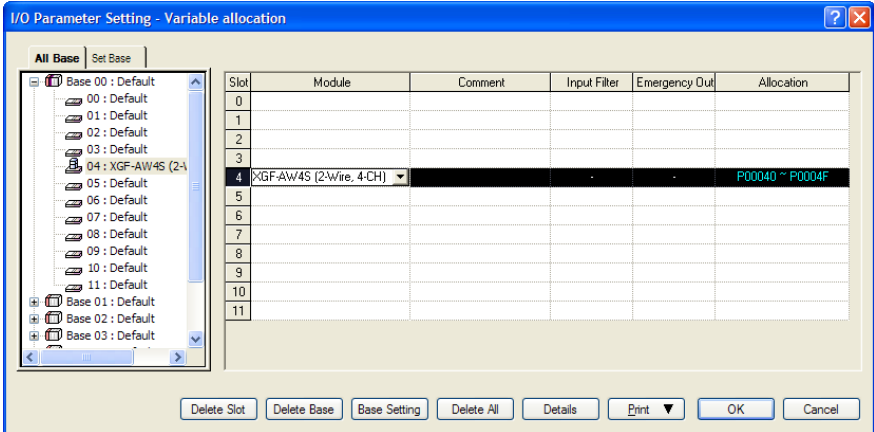

(6) A window will appear where you can set the parameters for each channel as shown below. If you click on the item you want to set, the parameters that you can set will be displayed.

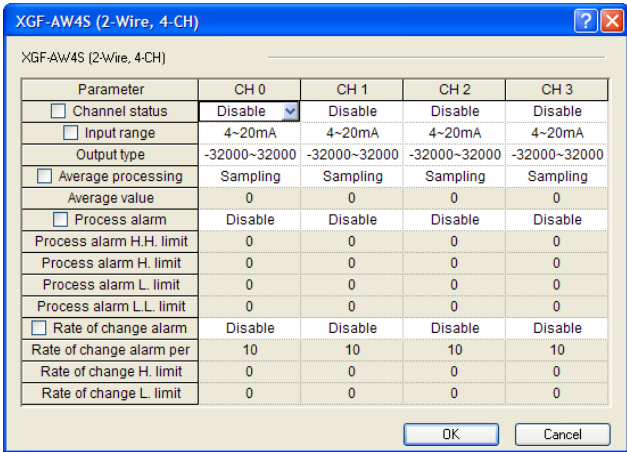

(a) Operating channel: chooses run or stop.

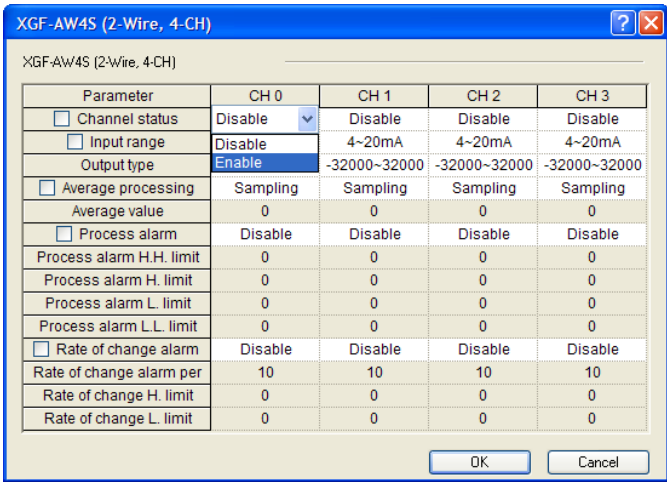

- (b) Input range: chooses the range of the analog input voltage you want to use.
 XGF-AW4S provides 1 current input range and 1 voltage input range.

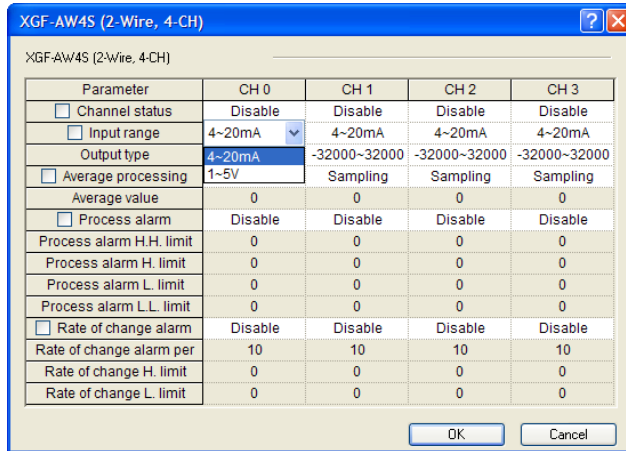

- (c) The output data type: chooses the output data type. You have 3 options.

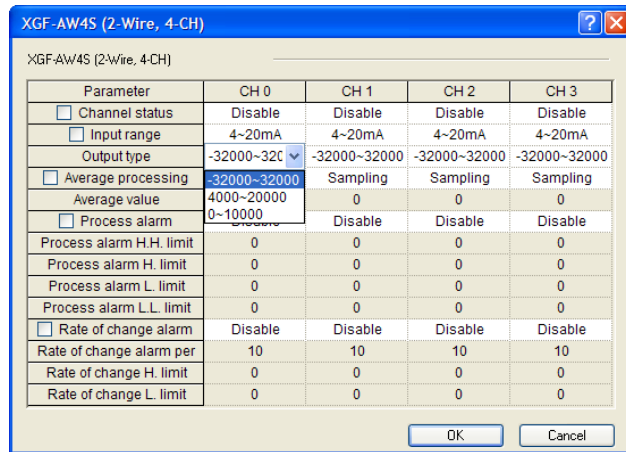

- (d) Average processing: you can choose the average processing type.

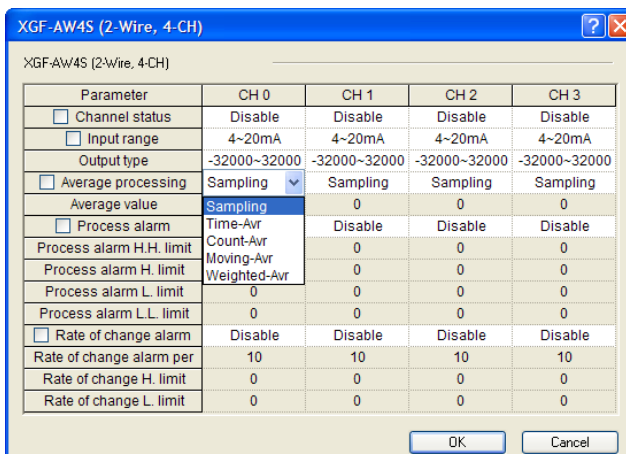

(e) Average: you can enter the average in this field only when you have set average processing as other values than [Sampling processing]. If you double-click on the average value with the average processing chosen, you can enter a value. The range of the values you can enter in this field is shown in Table 7.3.

[Table 7.3] The range of average processing setting

Average processing method	Range of values
Time	20 ~ 5000(ms)
Count	2 ~ 500(times)
Moving average	2 ~ 100(times)
Weighted average	1 ~ 99(%)

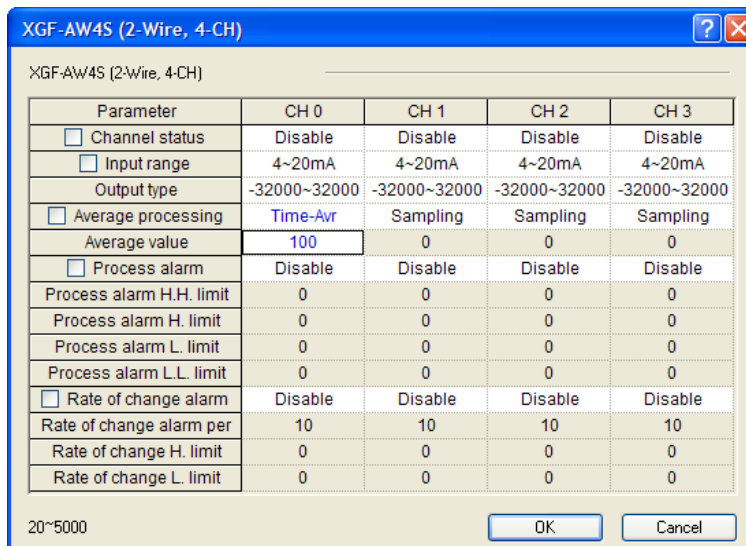

(f) Process alarm: you can enable or disable the process alarm.

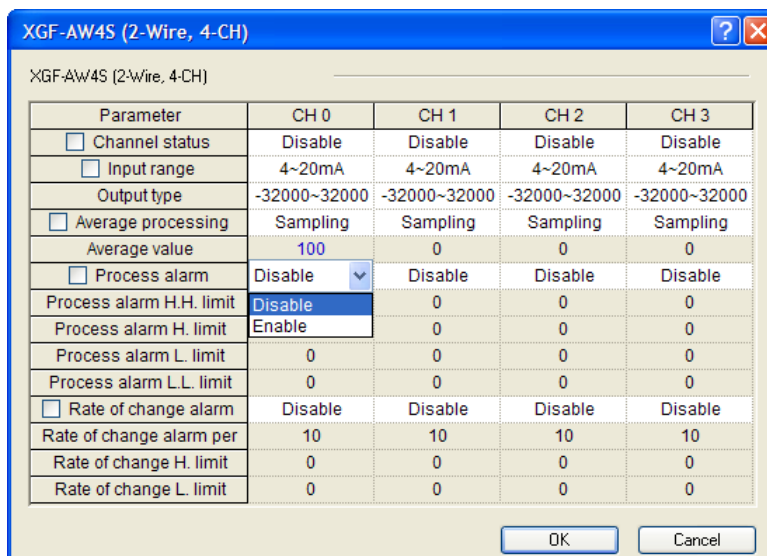

(g) Further upper ~ further lower limits of the process alarm: you can only change the values when the process alarm is set as [Allow]. The range of the input values is the same as that of the output data type.

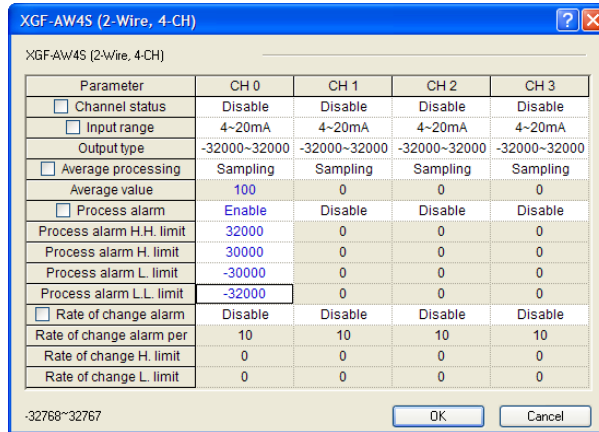

(h) Setting the change rate alarm: you can set the change rate alarm as allow or block.

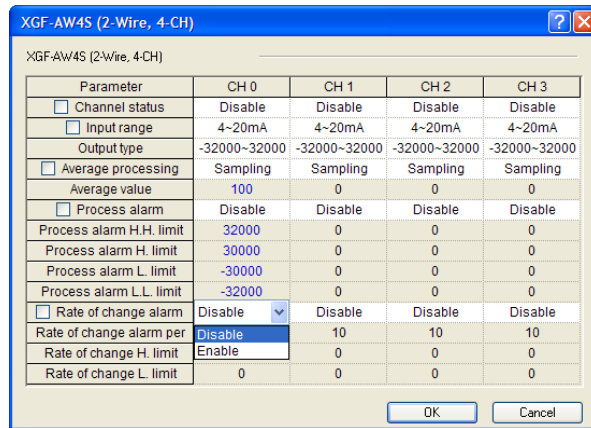

(i) Change rate alarm detection cycle: In this field, you can change the value only when the change rate alarm is set as [Allow]. If you double-click on the average value, you can enter a value in the field. The range of the values you can enter in this field is 10 (ms) ~ 5000 (ms). You cannot enter a value beyond this range.

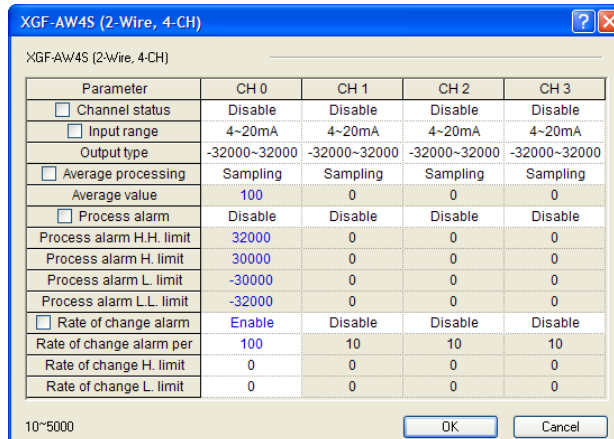

(j) Upper and lower limits of the change rate: In this field, you can change the value only when the change rate alarm is set as [Allow]. The range of the entered value is the same as that of the output data type.

(7) Change all parameter in line

If you want to change all the channels to the same set value, check the radio button in the parameter row. Then, if you change the parameter of a channel, the parameters of all the channels will change at the same time. Fig. 4.2 gives an example in which the operating channel is changed to all channel operating by using this function.

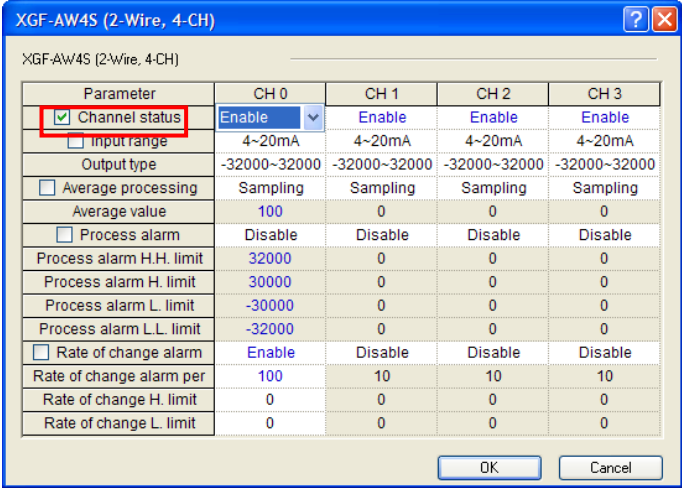

[Fig. 4.2] Change all channel parameters

4.3 Functions of the Special Module Monitor

Table 4.2 shows the functions of the special module monitor.

[Table 4. 2] The functions of the special module monitor

Item	Description	Note
[Special module monitor]	<p>(1) Monitor/test You can monitor the A/D conversion value or test the operating of the 2 wire input analog input module through the menu connected to [Monitor] of XG5000 -> [Special module monitor].</p> <p>(2) Minimum/maximum monitor You can monitor the minimum and maximum values of a running channel. The values you can see are the current values displayed on the screen. Therefore the minimum and maximum values are not saved when you close the [Monitoring/test] window.</p>	

Note

If there are not enough system resources of the PC you are using, the display may not be normally functioning. In such a case, close the window, end other applications and restart XG5000.

4.4 Precautions

- The parameters you set to test the Analog input module in the [Special module monitor] window are gone as soon as the [Special module monitor] window is closed. That is, the parameters of the analog input module set in the [Special module monitor] window are not saved in [I/O parameter] on the left tab of XG5000.

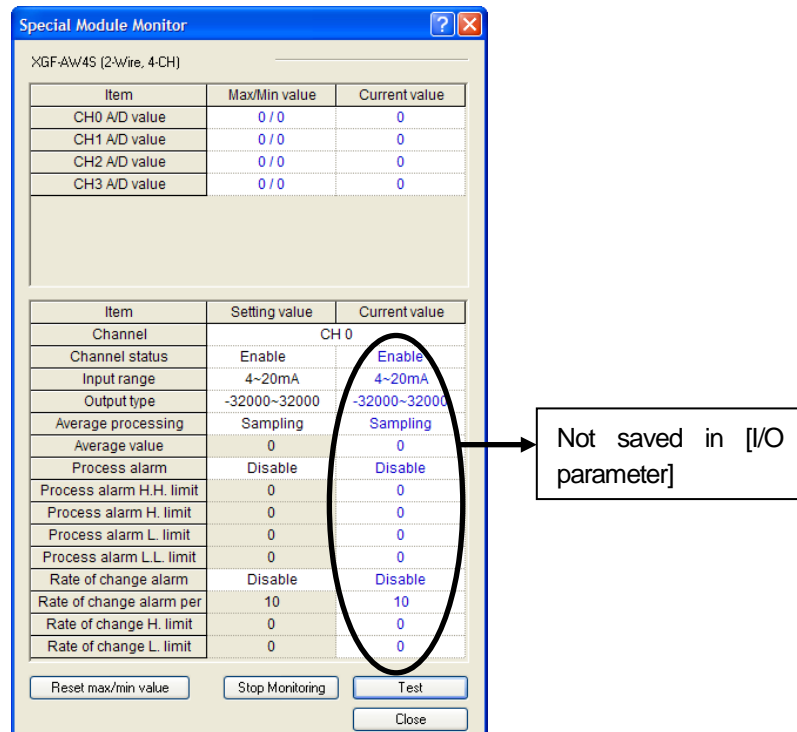

The test function of the [Special module monitor] is for checking whether the module operates normally when no sequence program has been configured. If you use the conversion module for other purposes than testing, it is recommended you use the parameter setting function in [I/O parameter].

4.5 How to Use the Special Module Monitor

This section gives information on how to use the special module monitor of the XGF-AW4S.

4.5.1 Starting [Special module monitor]

Go [Online] -> [Access], and then [Monitor] -> [Special module monitor]. If you are not in the [Online] status, the [Special module monitor] menu will not be activated.

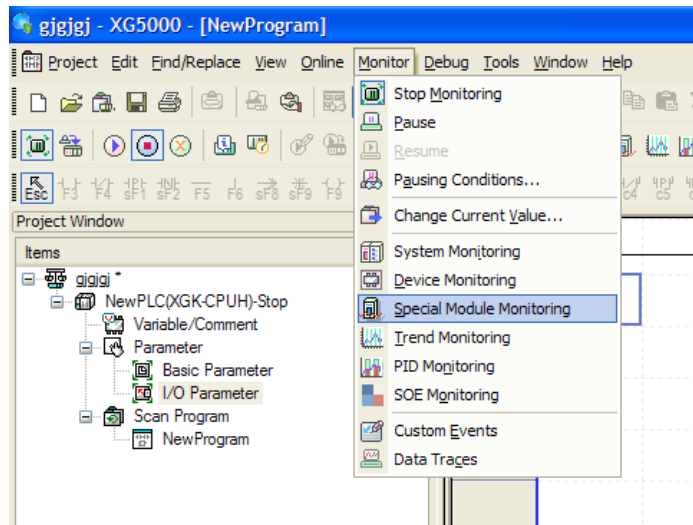

4.5.2 How to Use [Special module monitor]

(1) Click on [Monitor] -> [Special module monitor] with XG5000 connected to the PLC CPU module. Then the [Special module list] window will appear displaying the base/slot information along with the types of the special module as in [Fig. 5.1]. The list dialog box displays the module currently mounted in the PLC system.

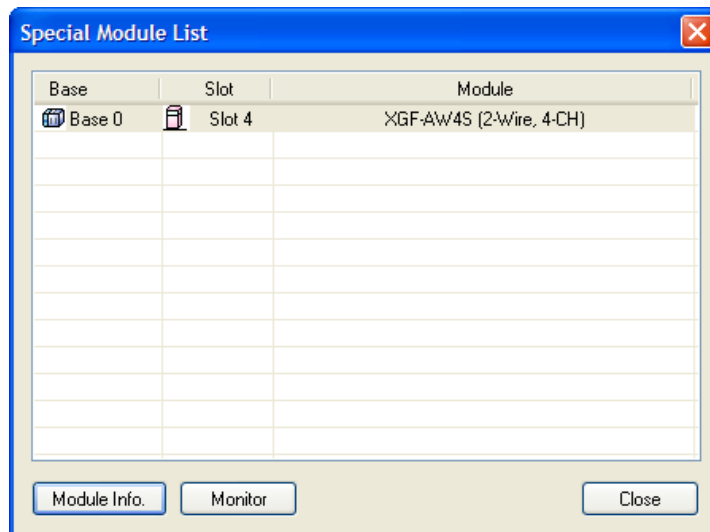

[Fig. 5. 1] [Select special module]

- (2) Select the special module and click on [Module information] in Fig. 5.1., and then the [Special module information] will appear as in Fig. 5.2.

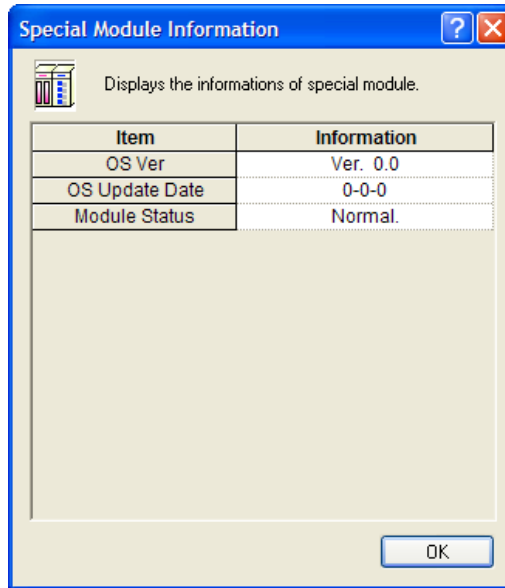

[Fig. 5. 2] [Select module information]

- (3) Click on the [Monitor] button in the [Special module list] in Fig. 5.1, and then the [Special module monitor] window will appear as in [Fig. 5.3].

There are 4 buttons of [Reset max/min], [Start monitoring], [Start test] and [Close] in this window. The monitor at the top of the screen displays the outputs of the analog input module and maximum/minimum values. In the test window at the bottom of the screen, you can configure the parameter items discretely of each module.

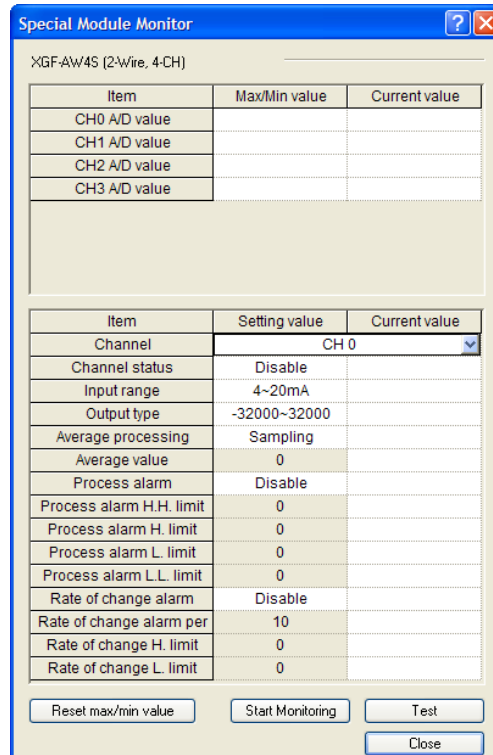

[Fig. 5. 3] [Special module monitor]

- (a) [Start monitor]: If you click on [Start monitor], the A/D conversion value of the currently running channel will be displayed. Fig. 5.4 is the monitoring that you see when AW4S is all channel stop status. The current value field at the bottom of the window displays the parameter of the currently set module.

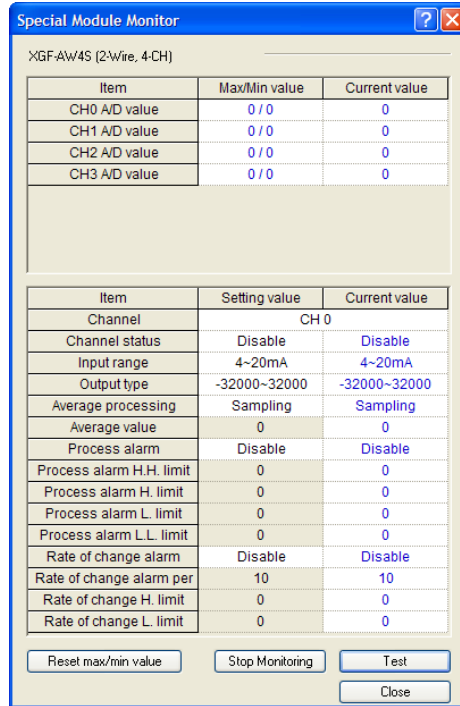

[Fig. 5. 4] The display of [Start monitor]

- (b) [Start test]: [Start test] is used when you want to change the parameter of the currently set module. You can change the parameter by clicking on the set value in the field at the bottom of the window. Fig. 5.5 is when you execute [Start test] after changing the input voltage range of channel 0 to 4 ~ 20mA.

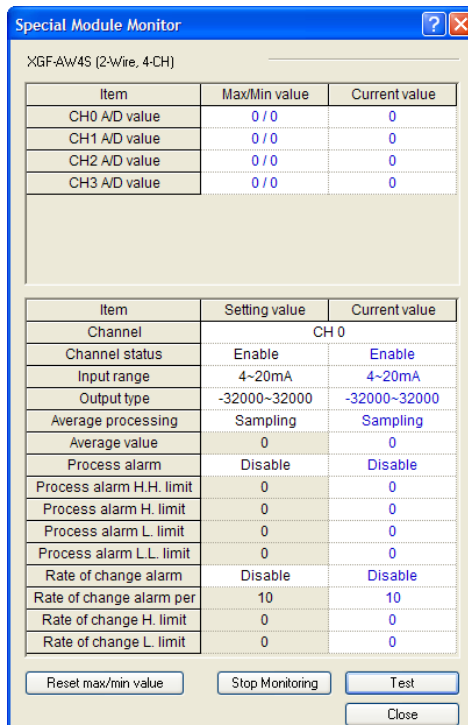

[Fig. 5. 5] [Start test]

- (c) [Reset max/min]: shows the maximum and minimum A/D conversion values at the top of the window. If you click on it, the maximum and minimum values are reset. Fig. 5.6 is when you click on [Reset max/min] in Fig. 5.5. As shown, the A/D conversion value of channel 0 has been reset.

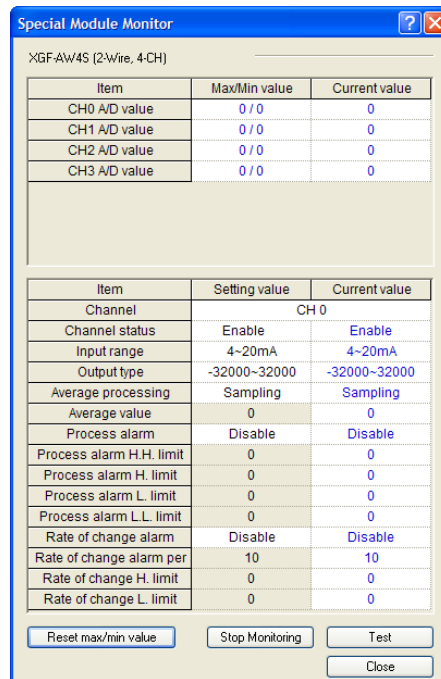

[Fig. 5. 6] [Reset max/min]

- (d) [Close]: used when you want to close the monitoring or test window. When you close the windows, the maximum, minimum and current values are not saved.

4.6 Automatic Registration of U Device

This section provides information on the automatic registration of U device of XG5000.

4.6.1 Automatic Registration of U Device

The variables for each module are automatically registered referring to the information of the special module set in [I/O parameter]. The user can modify the variables and the descriptions.

[Sequence]

- (1) Set the special module in the slot in [I/O parameter].

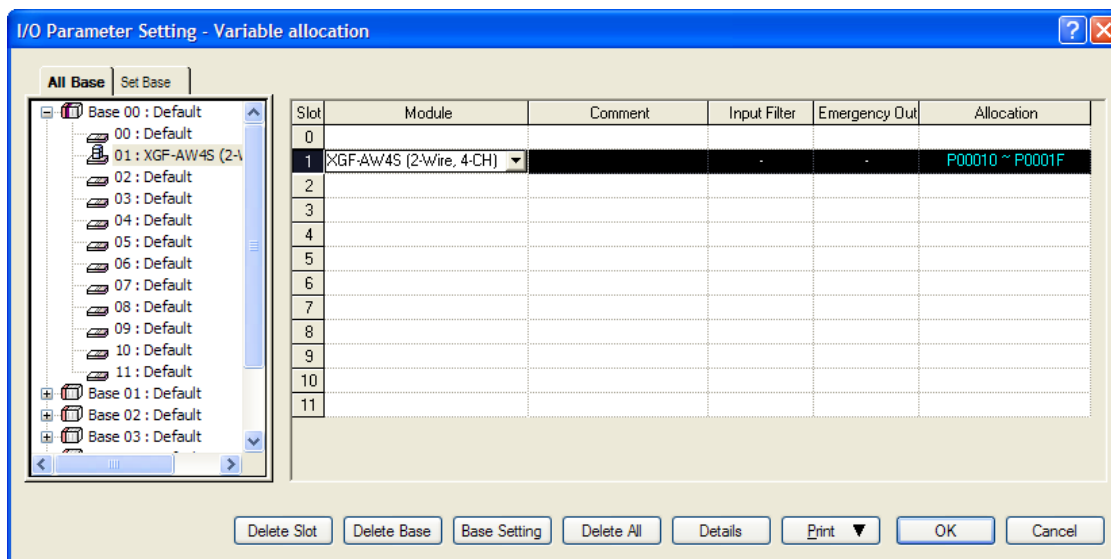

- (2) Double-click on [Variable/description].

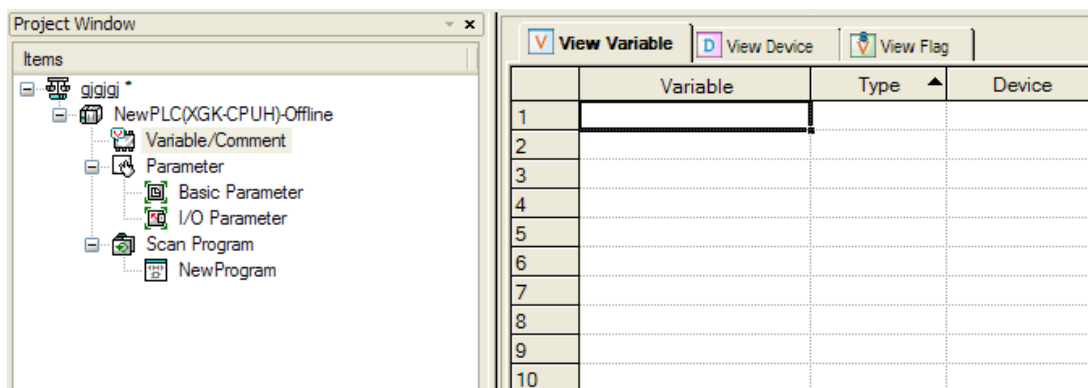

(3) Choose 'Automatic registration of U device' in [Edit] in the menu.

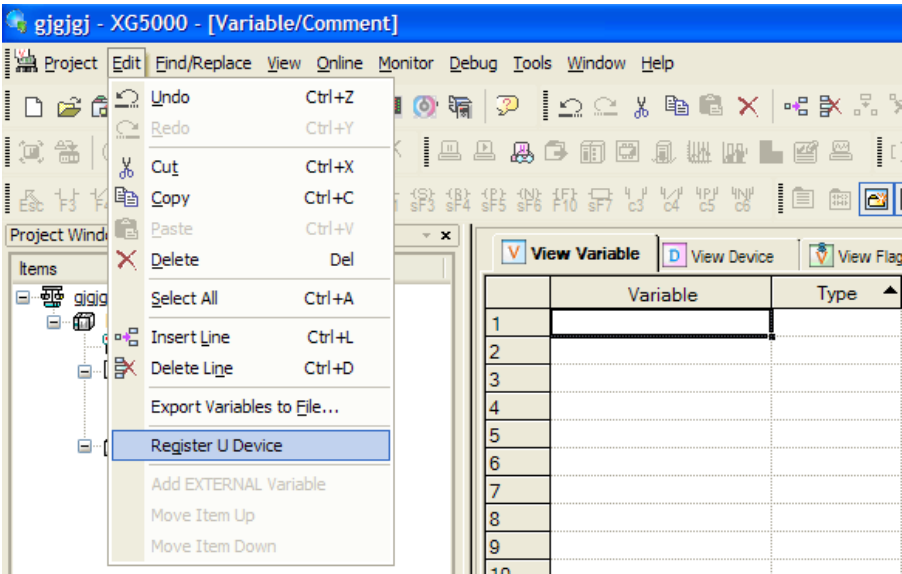

(4) Click on 'Yes.'

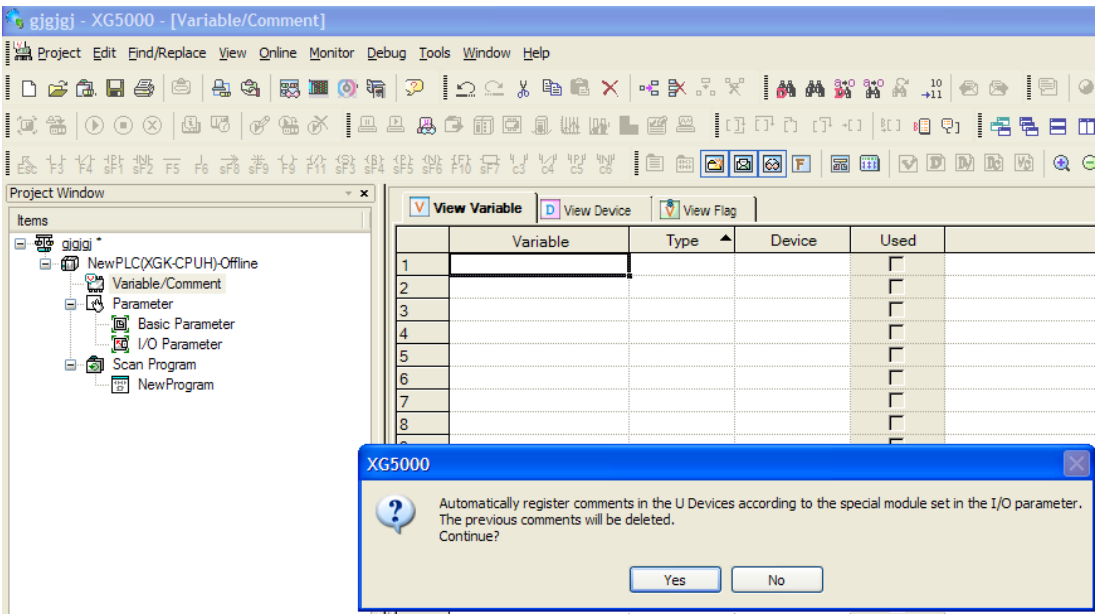

(5) The variables are registered as below.

View Variable View Device View Flag					
	Variable	Type	Device	Used	Comment
1	_01_ERR	BIT	U01.00.0	<input type="checkbox"/>	2-Wire Analog Input Module: Module Error
2	_01_RDY	BIT	U01.00.F	<input type="checkbox"/>	2-Wire Analog Input Module: Module Ready
3	_01_CH0_ACT	BIT	U01.01.0	<input type="checkbox"/>	2-Wire Analog Input Module: CH0 Running
4	_01_CH1_ACT	BIT	U01.01.1	<input type="checkbox"/>	2-Wire Analog Input Module: CH1 Running
5	_01_CH2_ACT	BIT	U01.01.2	<input type="checkbox"/>	2-Wire Analog Input Module: CH2 Running
6	_01_CH3_ACT	BIT	U01.01.3	<input type="checkbox"/>	2-Wire Analog Input Module: CH3 Running
7	_01_CH0_PALL	BIT	U01.08.0	<input type="checkbox"/>	2-Wire Analog Input Module: CH0 Process Alarm Low I
8	_01_CH0_PAL	BIT	U01.08.1	<input type="checkbox"/>	2-Wire Analog Input Module: CH0 Process Alarm Low I
9	_01_CH0_PAH	BIT	U01.08.2	<input type="checkbox"/>	2-Wire Analog Input Module: CH0 Process Alarm High
10	_01_CH0_PAHH	BIT	U01.08.3	<input type="checkbox"/>	2-Wire Analog Input Module: CH0 Process Alarm High
11	_01_CH1_PALL	BIT	U01.08.4	<input type="checkbox"/>	2-Wire Analog Input Module: CH1 Process Alarm Low I
12	_01_CH1_PAL	BIT	U01.08.5	<input type="checkbox"/>	2-Wire Analog Input Module: CH1 Process Alarm Low I
13	_01_CH1_PAH	BIT	U01.08.6	<input type="checkbox"/>	2-Wire Analog Input Module: CH1 Process Alarm High
14	_01_CH1_PAHH	BIT	U01.08.7	<input type="checkbox"/>	2-Wire Analog Input Module: CH1 Process Alarm High
15	_01_CH2_PALL	BIT	U01.08.8	<input type="checkbox"/>	2-Wire Analog Input Module: CH2 Process Alarm Low I
16	_01_CH2_PAL	BIT	U01.08.9	<input type="checkbox"/>	2-Wire Analog Input Module: CH2 Process Alarm Low I
17	_01_CH2_PAH	BIT	U01.08.A	<input type="checkbox"/>	2-Wire Analog Input Module: CH2 Process Alarm High
18	_01_CH2_PAHH	BIT	U01.08.B	<input type="checkbox"/>	2-Wire Analog Input Module: CH2 Process Alarm High
19	_01_CH3_PALL	BIT	U01.08.C	<input type="checkbox"/>	2-Wire Analog Input Module: CH3 Process Alarm Low I

4.6.2 Saving Variables

- (1) The content in the 'View variable' tab can be saved in text files.
- (2) Click on 'Save in text file' in 'Edit' in the menu.
- (3) The content in the 'View variable' tab is saved in a text file.

4.6.3 Viewing Variables in the Program

(1) The example program of XG5000 is as follows.

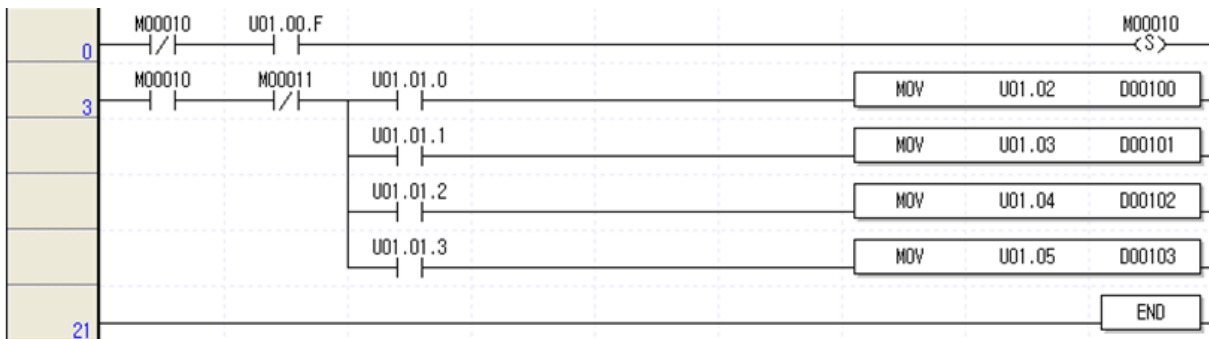

(2) Click on 'View variable' in 'View' in the menu. The devices become variables.

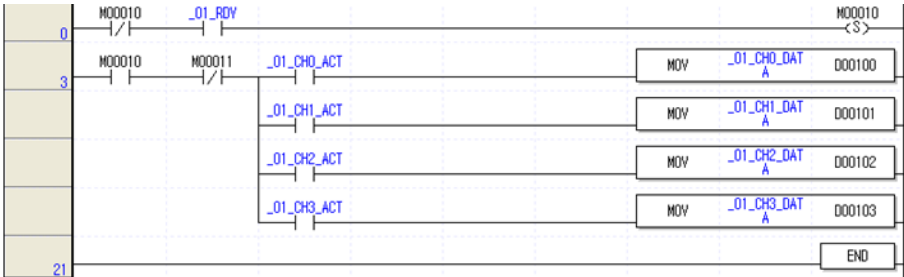

(3) Click on 'View device/variable' in 'View' in the menu. You can view the device and variable together at a time.

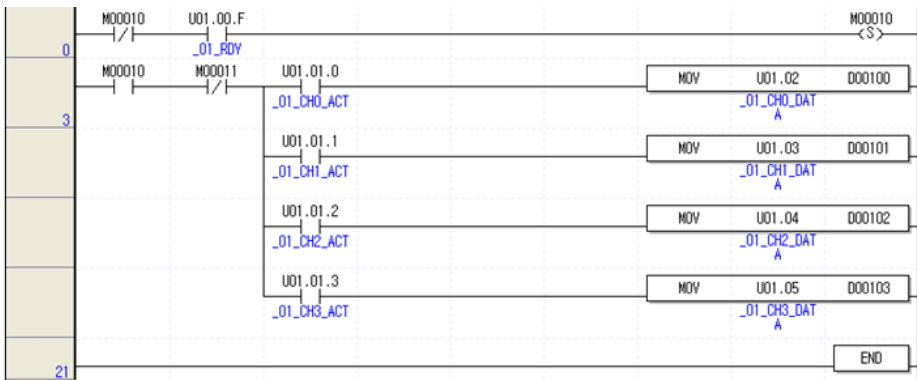

(4) Click on 'View device/description' in 'View' in the menu. You can view the device and description together at a time.

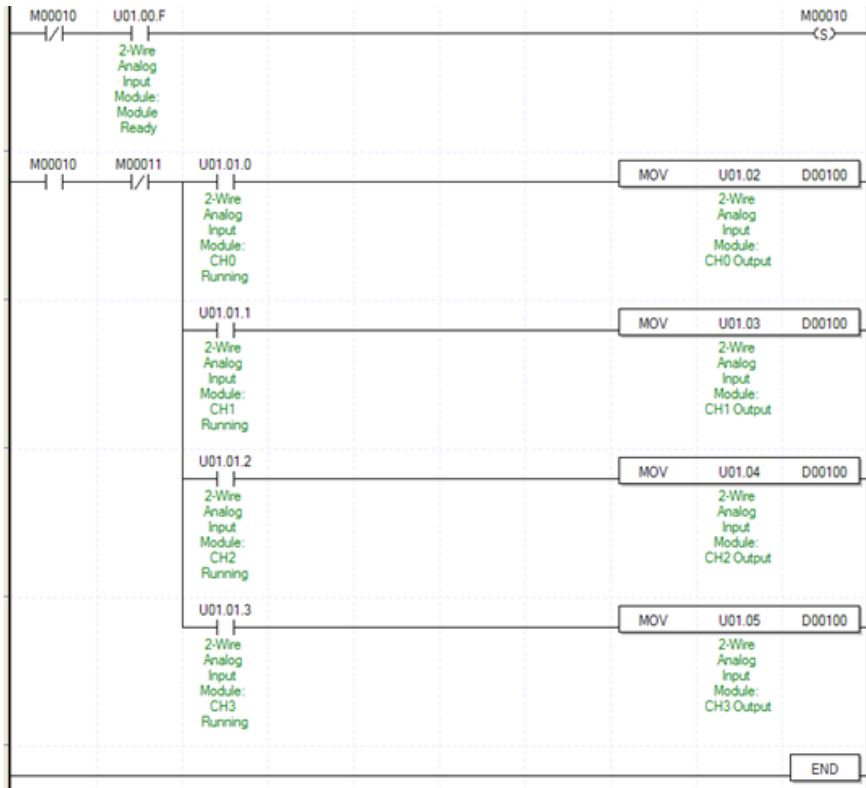

(5) Click on 'Variables/Comments' in 'View' in the menu. You can view the variables and comments together at a time.

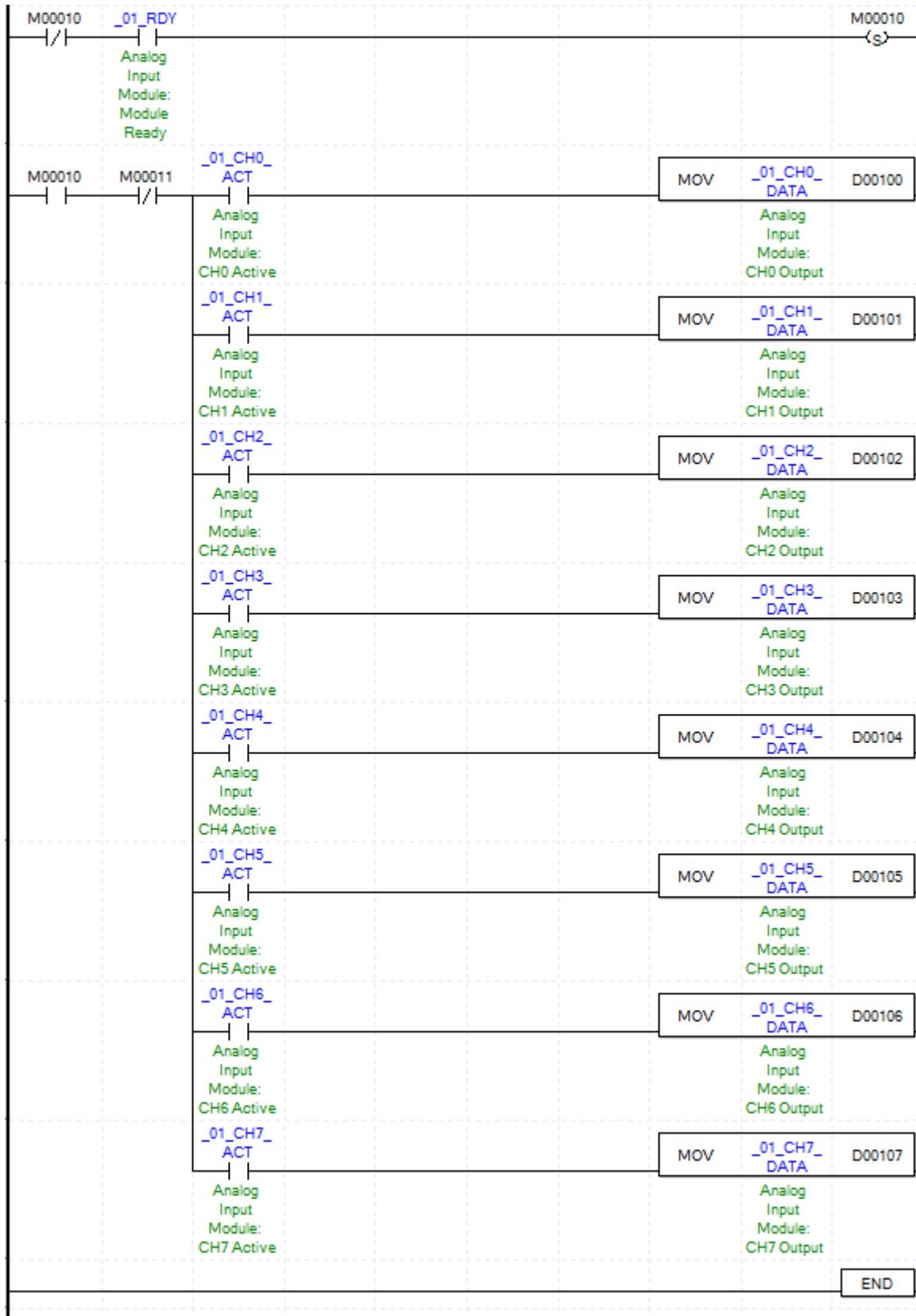

Chapter 5 Configuration and Functions of Internal Memory

The 2 wire analog input module has an internal memory for transmitting and receiving data with the PLC CPU.

5.1 The Configuration of the Internal Memory

This section gives information on the configuration of the internal memory.

5.1.1 Input and Output Data of the 2-Wire Analog Input Module

Table 5.1 shows the input and output ranges of the A/D conversion data.

[Table 5. 1] Input and output ranges of A/D conversion data

Device allocation	Description	R/W	Signal direction
UXY.00.0 UXY.00.F	Module ERROR flag Module READY flag	R	A/D → CPU
UXY.01.0 UXY.01.1 UXY.01.2 UXY.01.3	channel0 operating flag channel1 operating flag channel2 operating flag channel3 operating flag	R	A/D → CPU
UXY.02	Channel 0 digital output value	R	A/D → CPU
UXY.03	Channel 1 digital output value	R	
UXY.04	Channel 2 digital output value	R	
UXY.05	Channel 3 digital output value	R	
UXY.06	Unused	R	
UXY.07	Unused	R	
UXY.08.0 UXY.08.1 UXY.08.2 UXY.08.3 UXY.08.4 UXY.08.5 UXY.08.6 UXY.08.7 UXY.08.8 UXY.08.9 UXY.08.A UXY.08.B UXY.08.C UXY.08.D UXY.08.E UXY.08.F	Channel 0 process alarm further lower limit detection flag (LL) Channel 0 process alarm lower limit detection flag (L) Channel 0 process alarm upper limit detection flag (H) Channel 0 process alarm further upper limit detection flag (HH) Channel 1 process alarm further lower limit detection flag (LL) Channel 1 process alarm lower limit detection flag (L) Channel 1 process alarm upper limit detection flag (H) Channel 1 process alarm further upper limit detection flag (HH) Channel 2 process alarm further lower limit detection flag (LL) Channel 2 process alarm lower limit detection flag (L) Channel 2 process alarm upper limit detection flag (H) Channel 2 process alarm further upper limit detection flag (HH) Channel 3 process alarm further lower limit detection flag (LL) Channel 3 process alarm lower limit detection flag (L) Channel 3 process alarm upper limit detection flag (H) Channel 3 process alarm further upper limit detection flag (HH)	R	

Device allocation	Description	R/W	Signal direction
UXY.09.0 UXY.09.1 UXY.09.2 UXY.09.3 UXY.09.4 UXY.09.5 UXY.09.6 UXY.09.7	Channel 0 change rate alarm lower limit detection flag (L) Channel 0 change rate alarm upper limit detection flag (H) Channel 1 change rate alarm lower limit detection flag (L) Channel 1 change rate alarm upper limit detection flag (H) Channel 2 change rate alarm lower limit detection flag (L) Channel 2 change rate alarm upper limit detection flag (H) Channel 3 change rate alarm lower limit detection flag (L) Channel 3 change rate alarm upper limit detection flag (H)	R	
UXY.10.0 UXY.10.1 UXY.10.2 UXY.10.3	Channel 0 disconnection detection flag (1 ~ 5V or 4 ~ 20mA) Channel 1 disconnection detection flag (1 ~ 5V or 4 ~ 20mA) Channel 2 disconnection detection flag (1 ~ 5V or 4 ~ 20mA) Channel 3 disconnection detection flag (1 ~ 5V or 4 ~ 20mA)	R	A/D → CPU
UXY.11.0	Error clear request flag	W	CPU → A/D

- (1) In device allocation, X means the number of the base where the module is mounted and Y the number of the slot where the module is mounted.
- (2) The 'channel1 digital output value' of the module mounted in base 0 slot 4 is expressed as U04.03.

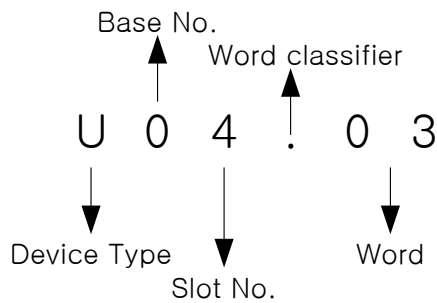

- (3) The channel 3 disconnection detection flag of the module mounted in base 0 slot 5 is expressed as U05.10.3.

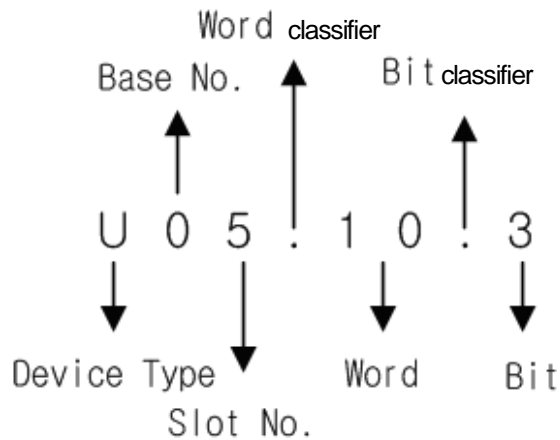

5.1.2 Operating Parameter Setting Range

Table 5.2 shows the operating parameter setting range of the 2 wire input analog input module

[Table 5. 2] Operating parameter setting ranges

Memory address		Description	R/W	Note
Hexadecimal	Decimal			
0H	0	Specify the channel in use	R/W	PUT
1H	1	Input voltage/current ranges	R/W	PUT
2H	2	Output data range	R/W	PUT
3H	3	Average processing	R/W	PUT
4H	4	Channel 0 average	R/W	PUT
5H	5	Channel 1 average		
6H	6	Channel 2 average		
7H	7	Channel 3 average		
8H	8	Alarm processing	R/W	PUT
9H	9	channel 0 process alarm further upper limit (HH)	R/W	PUT
AH	10	channel 0 process alarm upper limit (H)		
BH	11	channel 0 process alarm lower limit (L)		
CH	12	channel 0 process alarm further lower limit (LL)		
DH	13	channel 1 process alarm further upper limit (HH)		
EH	14	channel 1 process alarm upper limit (H)		
FH	15	channel 1 process alarm lower limit (L)		
10H	16	channel 1 process alarm further lower limit (LL)		
11H	17	channel 2 process alarm further upper limit (HH)		
12H	18	channel 2 process alarm upper limit (H)		
13H	19	channel 2 process alarm lower limit (L)		
14H	20	channel 2 process alarm further lower limit (LL)		
15H	21	channel 3 process alarm further upper limit (HH)		
16H	22	channel 3 process alarm upper limit (H)		
17H	23	channel 3 process alarm lower limit (L)		
18H	24	channel 3 process alarm further lower limit (LL)		
19H	25	channel 0 change rate alarm detection cycle	R/W	PUT
1AH	26	channel 1 change rate alarm detection cycle		
1BH	27	channel 2 change rate alarm detection cycle		
1CH	28	channel 3 change rate alarm detection cycle		
1DH	29	channel 0 change rate alarm upper limit	R/W	PUT
1EH	30	channel 0 change rate alarm lower limit		
1FH	31	channel 1 change rate alarm upper limit		
20H	32	channel 1 change rate alarm lower limit		
21H	33	channel 2 change rate alarm upper limit		
22H	34	channel 2 change rate alarm lower limit		
23H	35	channel 3 change rate alarm upper limit		
24H	36	channel 3 change rate alarm lower limit		
25H	37	Error code	R/W	GET

※ R/W means Read/write from the PLC program.

5.2 A/D Conversion Data Input/Output Ranges

5.2.1 Module READY/ERROR Flag (UXY.00, X: base number, Y: slot number)

- (1) **UXY.00.F** : On when the A/D conversion is ready with the PLC CPU supplied with power or reset, and conducts A/D conversion
- (2) **UXY.00.0** : the flag displaying errors of the module.

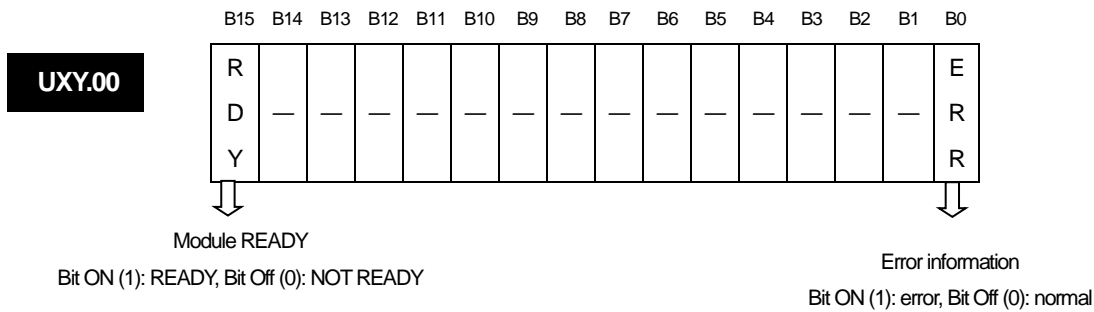

5.2.2 Operating channel flag (UXY.01, X: base number, Y: slot number)

This is the area where the operating information for each channel is stored.

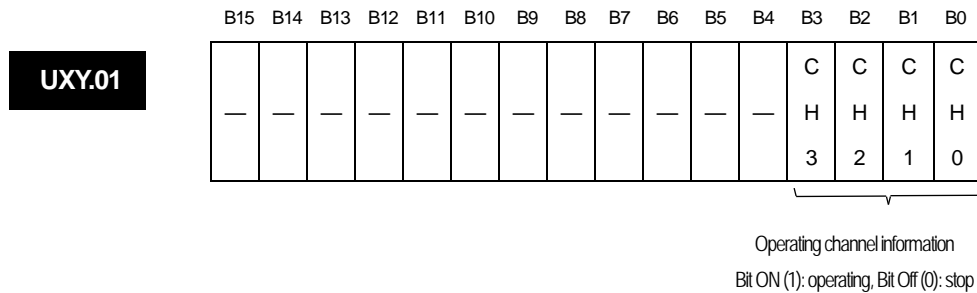

5.2.3 Digital output value (UXY.02 ~ UXY.05, X: base number, Y: slot number)

- (1) The A/D converted digital output value is output for each channel in the buffer memory address 2 ~ 9(UXY.02 ~ UXY.09).
- (2) The digital output values are saved in binary numbers of 16 bit.

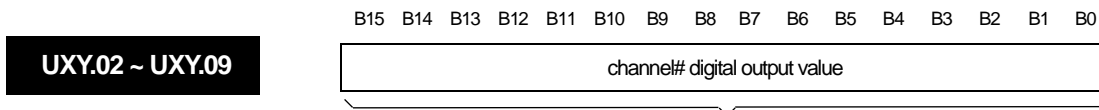

Address	Description
2	channel0 digital output value
3	channel1 digital output value
4	channel2 digital output value
5	channel3 digital output value

5.2.4 Process alarm detection flag (UXY.08.Z, X: base number, Y: slot number, Z: threshold alarm bit for channel)

- (1) The process alarm detection signal for each input channel is saved in UXY.08.
- (2) Each bit is set as 1 when a process alarm is detected for the allocated channel, and returns to 0 when the process alarm detection is restored. In addition, each bit can be used for process alarm detection in the user program as the execution conditions.

	B15	B14	B13	B12	B11	B10	B9	B8	B7	B6	B5	B4	B3	B2	B1	B0
UXY.08	C	C	C	C	C	C	C	C	C	C	C	C	C	C	C	C
	H	H	H	H	H	H	H	H	H	H	H	H	H	H	H	H
	3	3	3	3	2	2	2	2	1	1	1	1	0	0	0	0
	H	H	L	L	H	H	L	L	H	H	L	L	H	H	L	L
	H			L	H			L	H			L	H			L

BIT	Description
0	Within the setting range
1	Beyond the setting range

5.2.5 Change rate alarm detection flag (UXY.09.Z, X: base number, Y: slot number, Z: threshold alarm bit for channel)

- (1) The change rate alarm detection signal for each input channel is saved in UXY.09.
- (2) Each bit is set as 1 when a change rate alarm is detected for the allocated channel, and returns to 0 when the change rate alarm detection is restored. In addition, each bit can be used for change rate alarm detection in the user program as the execution conditions

	B15	B14	B13	B12	B11	B10	B9	B8	B7	B6	B5	B4	B3	B2	B1	B0
UXY.09	—	—	—	—	—	—	—	—	Channel 3H	Channel 3L	Channel 2H	Channel 2L	Channel 1H	Channel 1L	Channel 0H	Channel 0L
	—	—	—	—	—	—	—	—	—	—	—	—	—	—	—	—

BIT	Description
0	Within the setting range
1	Beyond the setting range

5.2.6 Disconnection detection flag (UXY.10.Z, X: base number, Y: slot number, Z: channel number)

- (1) The disconnection detection signals for each input channel is stored in UXY.10.
- (2) Each bit is set as 1 when a disconnection is detected for the allocated channel, and turns into 0 when the disconnection is recovered. Each bit can be used for disconnection detection in the user program as the operating conditions.

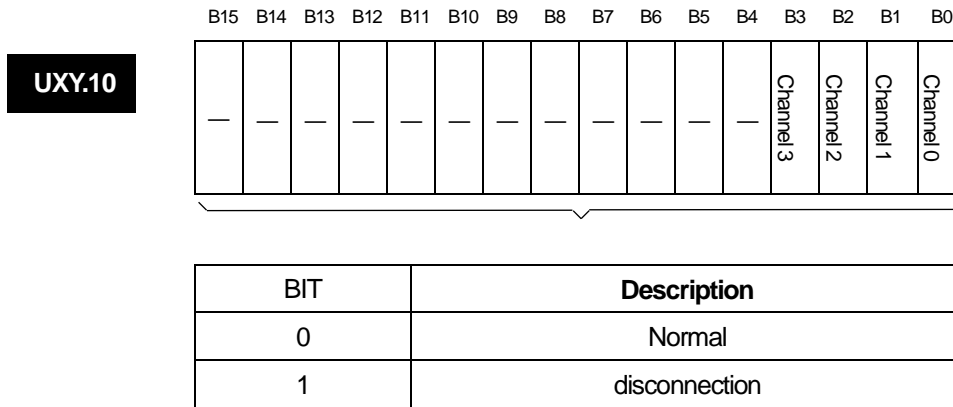

5.2.7 Error clear request flag (UXY.11.0, X: base number, Y: slot number)

- (1) When there is a parameter setting error, the error code of address 37 is not automatically deleted even if you change the parameter to a correct value. If you turn on the error clear request bit, the error displayed in [System monitor] of XG5000 is deleted. RUN LED also turns to On from Flashing
- (2) You have to use the error clear request flag along with UXY.00.0 for normal operating as shown in Fig. 5.1.

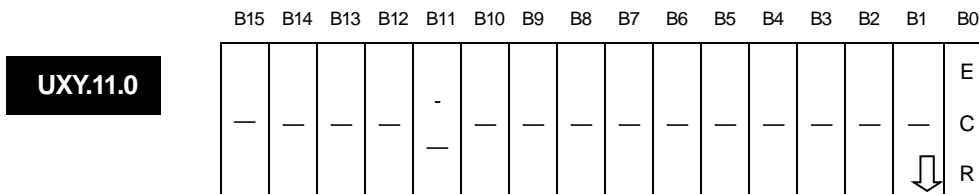

Error clear request flag (UXY.11.0)
Bit ON (1): error clear request, Bit Off (0): error clear stand-by

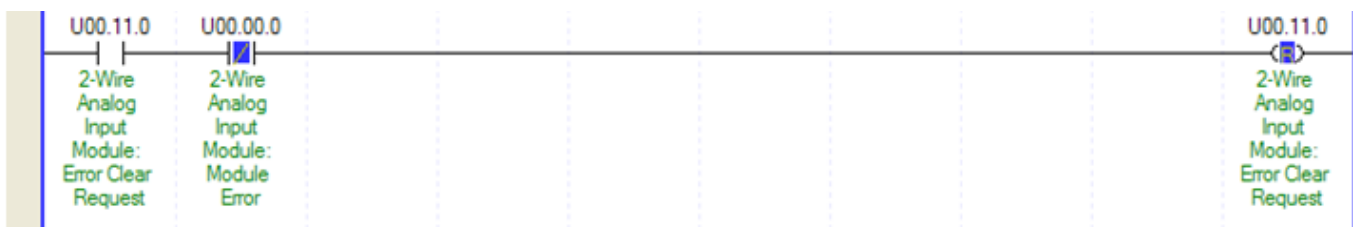

[Fig. 5. 1] How to use the error clear request flag

5.3 Operating Parameter Setting Ranges

- ▶ Each address of the internal memory is occupied by 1 word, which can be expressed in 16 bit. Each function can be used by setting the 16 bit that comprises the address at 1 when On for each bit and at 0 when Off for each bit.

5.3.1 Designation of the channel to use (address 0)

- (1) You can set whether to allow/block A/D conversion for each channel.
- (2) When no channel is designated for use, all the channels are set as not used.
- (3) Allow/block of A/D conversion is as follows.

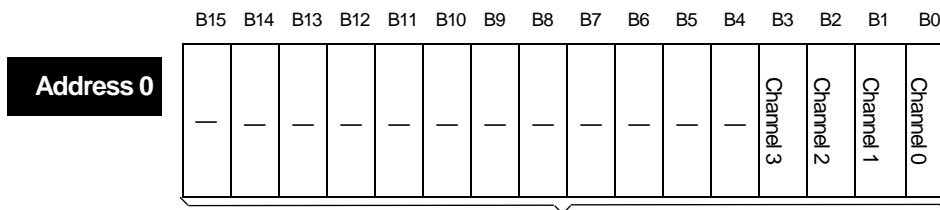

BIT	Description
0	Stop
1	Running

- (4) The values set at B4 ~ B15 will be ignored.

5.3.2 Output Voltage/Current Ranges (Addresses 1)

- (1) You can set the ranges of the analog input voltage/current for each channel.
- (2) When no analog input range is specified, all the channels are set as 4 ~ 20 mA.
- (3) The ranges of the analog input voltage/current are set as follows.

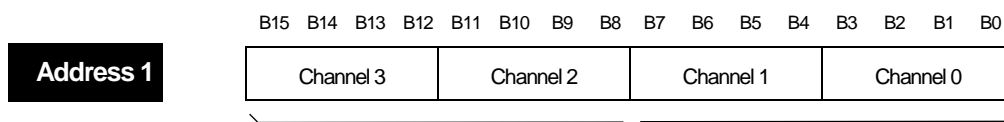

BIT	Ranges
0000	4 mA ~ 20 mA
0001	1 V ~ 5 V

5.3.3 Output Data Ranges (Address 2)

- (1) You can set the ranges of the digital output data for analog input for each channel.
- (2) When no output data range is specified, all the channels are set as -32000 ~ 32000.
- (3) The ranges of the digital output data are as follows.

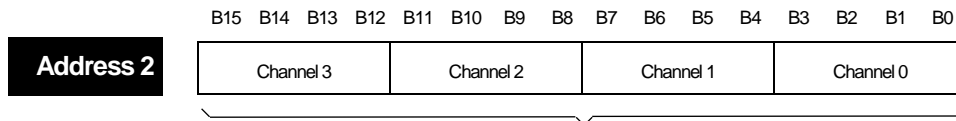

BIT	Description
00	-32000 ~ 32000
01	Precise Value
10	0 ~ 10000

The precise values have the following digital output ranges for the analog input range.

(a) Current

Analog input	4 ~ 20 mA
Digital output	
Precise Value	4000 ~ 20000

(b) Voltage

Analog input	1 ~ 5 V
Digital output	
Precise Value	1000 ~ 5000

5.3.4 Average Processing (Address 3)

- (1) You can set the average processing method for each channel.
- (2) When no average processing method is designated, all the channels conduct sampling processing.
- (3) The average processing is designated as follows.

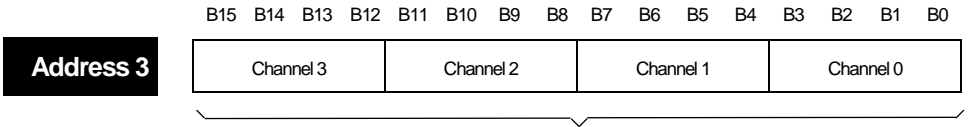

BIT	Description
0000	Sampling processing
0001	Time average
0010	Number average
0011	Moving average
0100	Weighted average

5.3.5 Average Value (Addresses 4~7)

- (1) The initial value of the average range is 0.
- (2) The setting ranges of averages are as follows.

Average processing method	ranges
Time average	20 ~ 5000(ms)
Number average	2 ~ 500 (number of times)
Moving average	2 ~ 100 (number of times)
Weighted average	0 ~ 99(%)

- (3) If you set a value beyond the setting range, the error code display address (address 37) is displays the error code. Then the A/D conversion value remains the previous data (# of the error code means the channel where the error occurred).
- (4) The setting of the average values is as follows.

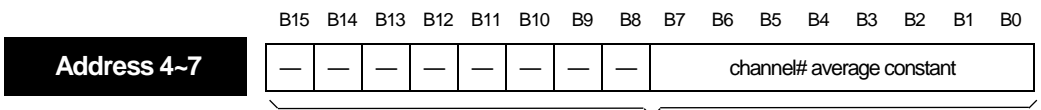

The setting ranges of the averages differ according to the average processing method.

Address	Description
Address 4	Sets the average of channel 0
Address 5	Sets the average of channel 1
Address 6	Sets the average of channel 2
Address 7	Sets the average of channel 3

Note

For the average to be effective, you need to designate the average processing method in advance.

5.3.6 Alarm Processing (Address 8)

- (1) This is the area where you designate whether to allow/block alarm processing for each channel.
- (2) The initial value of alarm processing is 0.
- (3) The setting of the alarm processing is as follows.

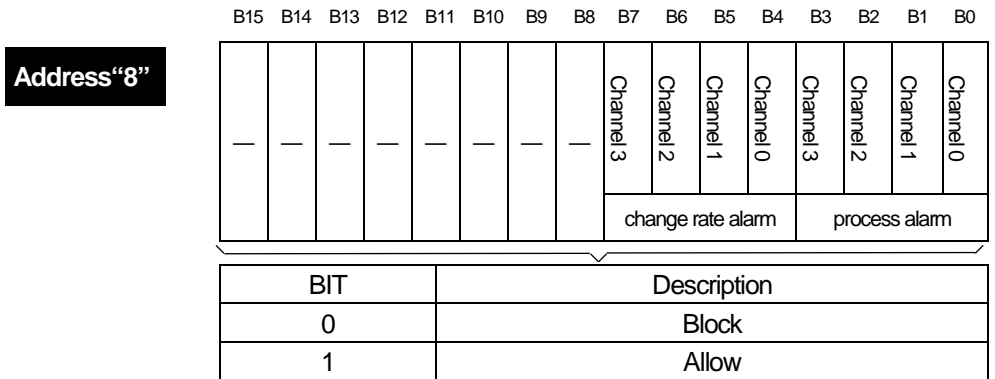

5.3.7 Process alarm setting values (Address 9 ~ 24)

- (1) This is the area where you designate the process alarm setting values for each channel. The ranges differ according to that of the output data.

- 1) Signed value: -32768 ~ 32767
- 2) Precise value

4 ~ 20 mA	3808 ~ 20192
1 ~ 5 V	952 ~ 5048

- 3) Percentile value: -120 ~ 10120

- (2) For details of the process alarm function, see 2.5.2.

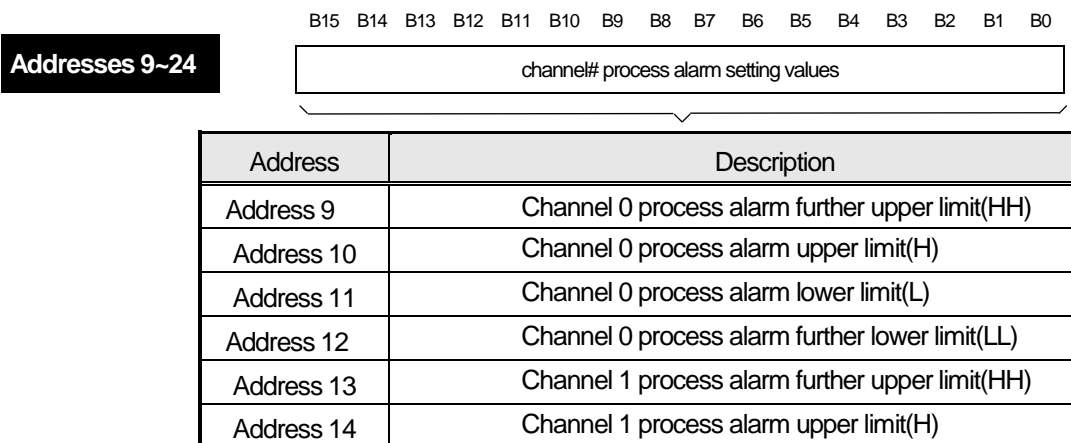

Address	Description
Address 15	Channel 1 process alarm lower limit(L)
Address 16	Channel 1 process alarm further lower limit(LL)
Address 17	Channel 2 process alarm further upper limit(HH)
Address 18	Channel 2 process alarm upper limit(H)
Address 19	Channel 2 process alarm lower limit(L)
Address 20	Channel 2 process alarm further lower limit(LL)
Address 21	Channel 3 process alarm further upper limit(HH)
Address 22	Channel 3 process alarm upper limit(H)
Address 23	Channel 3 process alarm lower limit(L)
Address 24	Channel 3 process alarm further lower limit(LL)

Note

You should set the process alarm at allow in advance if you want to set the process alarm value.

5.3.8 Change rate alarm detection cycle (Addresses 25 ~ 28)

- (1) The setting range of the change rate alarm detection cycle is 10 ~ 5000(ms).
- (2) If you set a value beyond the setting range, the error code 60# is displayed in the error code display address. Then the change rate alarm detection cycle is calculated with the initial value (10) applied.
- (3) The setting of the change rate alarm detection cycle is as follows.

B15 B14 B13 B12 B11 B10 B9 B8 B7 B6 B5 B4 B3 B2 B1 B0

Addresses 25~28

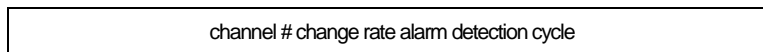

The change rate alarm detection cycle setting range is 10 ~ 5000(ms).

Address	Description
Address 25	Channel 0 change rate alarm detection cycle
Address 26	Channel 1 change rate alarm detection cycle
Address 27	Channel 2 change rate alarm detection cycle
Address 28	Channel 3 change rate alarm detection cycle

Note

When you designate the change rate alarm detection cycle, you should set the Address 25 processing as Allow. Also, designate the change rate alarm upper limit/lower limit.

5.3.9 Change rate alarm setting value (Addresses 29 ~ 36)

- (1) The range of the change rate alarm setting values is -32768 ~ 32767(-3276.8% ~ 3276.7%).
- (2) The designation of the change rate alarm setting values is as follows.

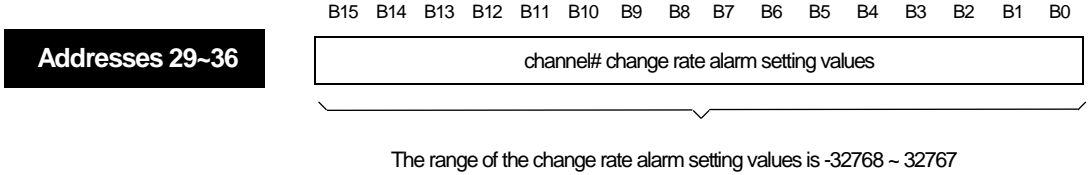

Addresses	Description
Address 29	channel 0 change rate alarm upper limit(H)
Address 30	channel 0 change rate alarm lower limit(L)
Address 31	channel 1 change rate alarm upper limit(H)
Address 32	channel 1 change rate alarm lower limit(L)
Address 33	channel 2 change rate alarm upper limit(H)
Address 34	channel 2 change rate alarm lower limit(L)
Address 35	channel 3 change rate alarm upper limit(H)
Address 36	channel 3 change rate alarm lower limit(L)

Note
 When you designate the change rate alarm detection cycle, you should set the change rate alarm processing as Allow. Also, designate the change rate alarm upper limit/lower limit.

5.3.10 Error Code (Address 37)

- (1) This saves the error code detected by the Analog input module.
- (2) The types and descriptions of the errors are as follows.



For the details of the error codes, see the table below.

Error code (Decimal)	Description of the error	Note
0	Normal operation	RUN LED on
10	module error (ASIC Reset Error)	RUN LED flashes every 0.2 second
11	module error (ASIC RAM or Register Error)	
20#	Beyond the time average setting range	RUN LED flashes every second
30#	Beyond the number average setting range	
40#	Beyond the moving average setting range	
50#	Beyond the weighted average setting range	
60#	Beyond the change rate alarm detection cycle setting range	
80#	Offset/gain error within range of 4~20mA	
81#	Offset/gain error within range of 1~5V	

※ # of the error code means the channel where the error occurred.

※ For details of the error codes, see 7.1.

- (3) If there are two or more errors, the module saves the error code that happened first and does not save the following error codes
- (4) If there is an error, you should use the error clear request flag (see 5.2.7) or turn the power supply Off → On after the error is corrected so that the LED stops flashing and the error code is deleted

Chapter 6 Programming (XGK)

6.1 Read/Write of the Operating Parameter Setting Ranges

This chapter describes the configuration of the internal memory.

6.1.1 Reading the Operating Parameter Setting Ranges (GET, GETP commands)

Form

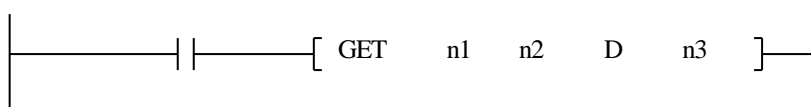

Form	Description	Available ranges
n1	The number of slot where special module is mounted	Integers
n2	The first address of special module operating parameter setting range to read the data	Integers
D	The first address of the device to save the data that is read	M, P, K, L, T, C, D, #D, Integer
n3	The number of words of the data to read	Integers

< Differences between GET and GETP commands >

GET: always executed with condition On()

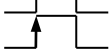
GETP: executed with condition started ()

E.g. When the 2 wire input analog input module is mounted in base 0 slot 3 and the data of the internal memory address 0 and 1 of the Analog input module are read through D0 and D1 of the CPU module

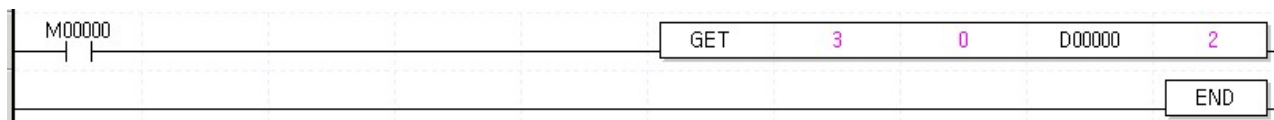
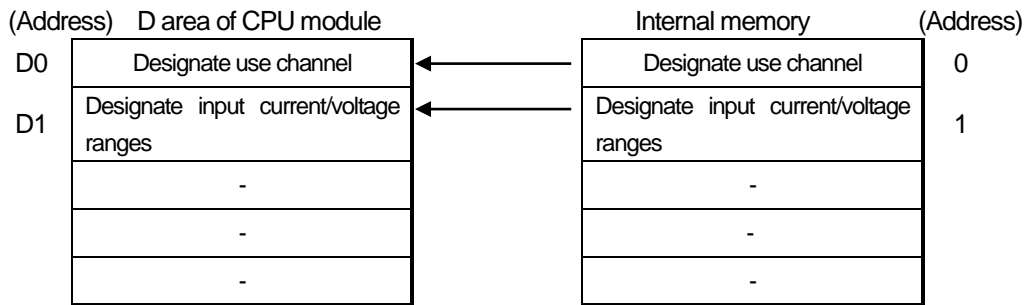

6.1.2 Reading Operating Parameter Setting Ranges (PUT, PUTP commands)

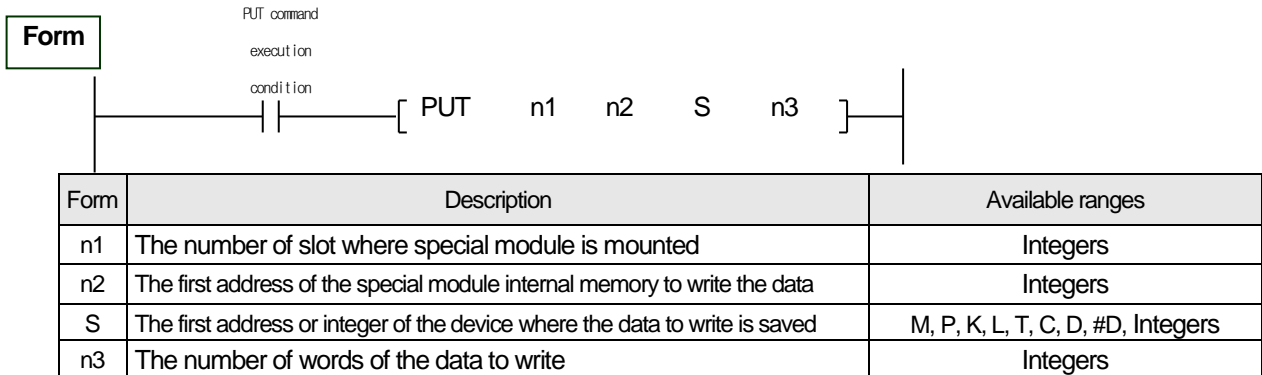

< Differences between PUT and PUTP commands >

PUT: always executed with condition On ()
 PUTP: executed with condition started ()

E.g. When the 2 wire input analog input module is mounted in base 0 slot 6 and the data D3 ~ D6 of the CPU module is written in internal memory addresses 3~6 of the 2 wire input analog input module

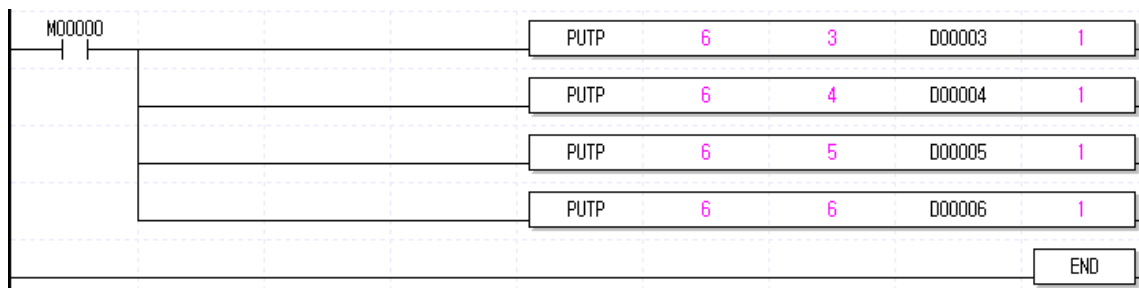
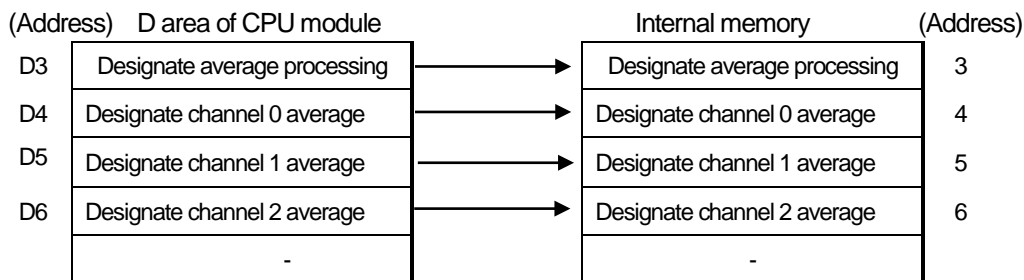

6.2 The Basic Program

- This chapter provides information on how to set the operating conditions for the internal memory of the 2 wire input analog input module.
- The 2 wire input analog input module is mounted in slot 2.
- The input and output occupancy point of the 2 wire input analog input module is 64 points (fixed).
- The initial setting condition is one time entry. The setting of the initial value is saved in the internal memory of the 2 wire input analog input module.

6.2.1 XGF-AW4S

- (1) An example of a program that uses [I/O parameter] setting

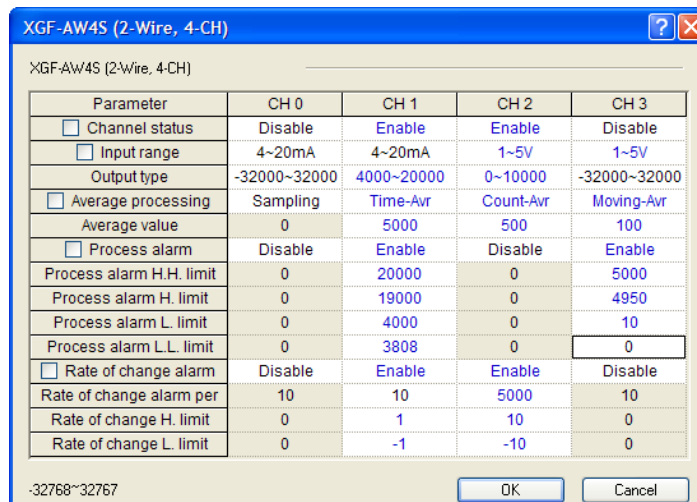
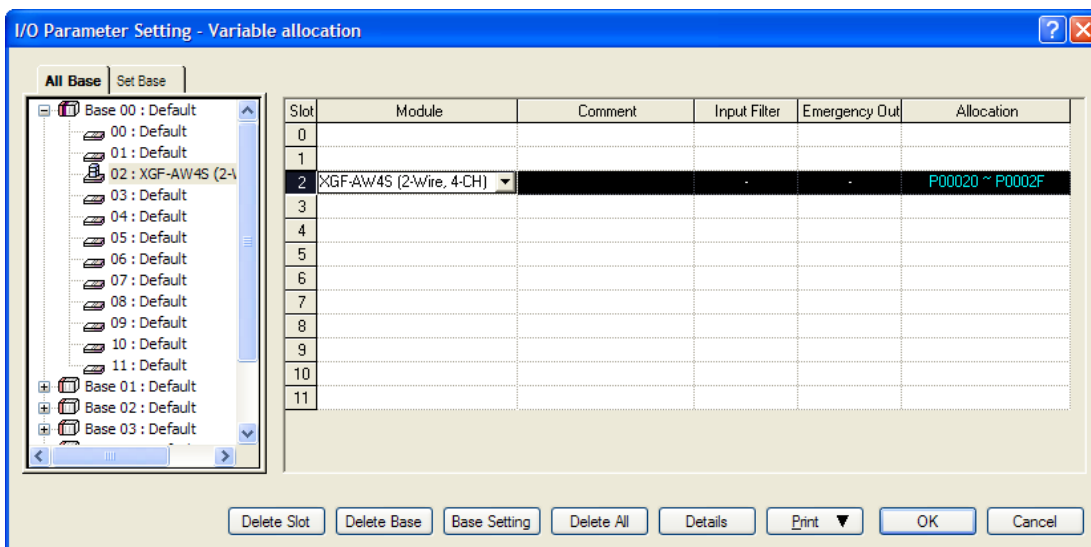

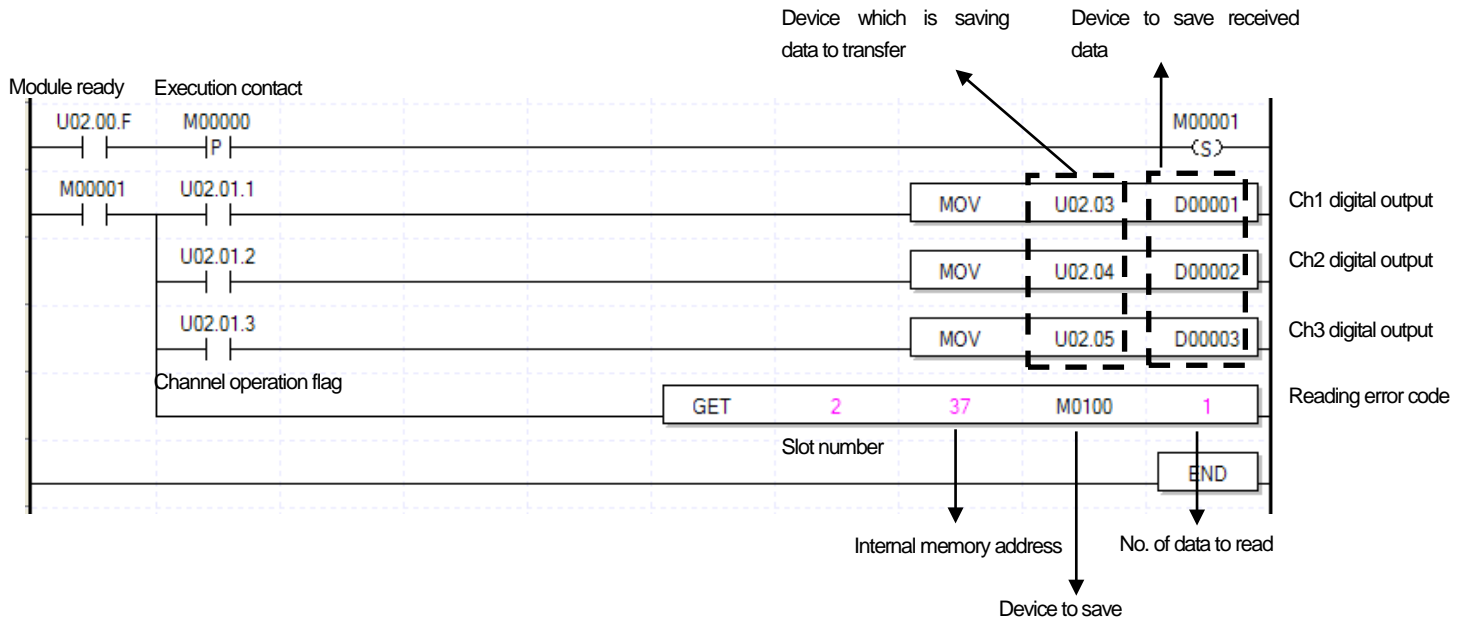

(2) An example of a program that uses PUT/GET commands

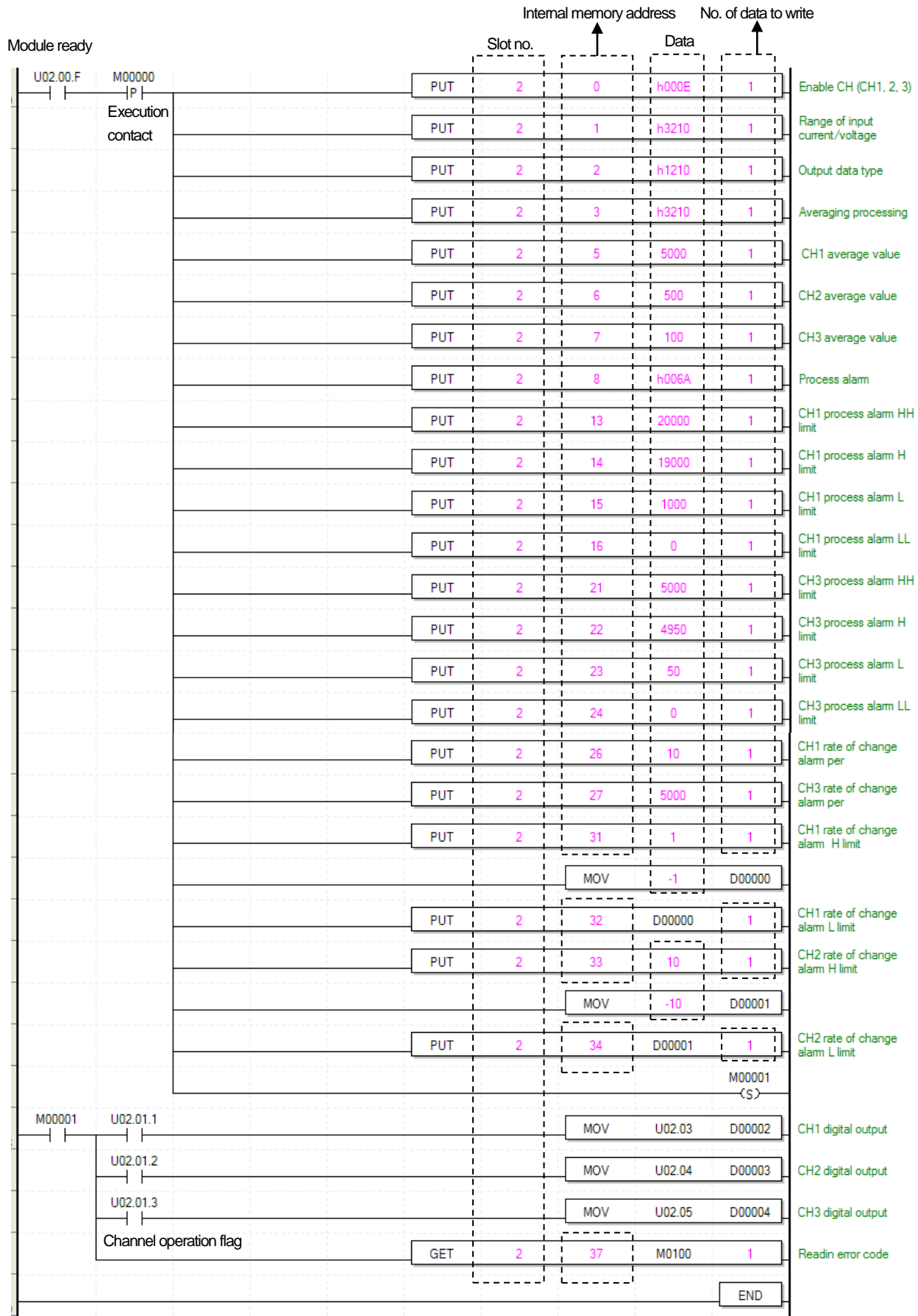

6.3 Applied Program

6.3.1 The Program Distinguishing A/D Conversion Values (I/O slot fixed point allocation: 64 points))

(1) System configuration

XGP- ACF2	XGK- CPUS	XGI- D22A	XGF- AW4S	XGQ- RY2A	
--------------	--------------	--------------	--------------	--------------	--

(2) Initial setting

No.	Item	Initial setting	Internal memory address	Values to write in internal memory
1	Channel in use	Channel 0, channel 2, channel 3	0	'h000D' or '13'
2	Input voltage range	1 ~ 5V	1	'h1101' or '4353'
3	Output data range	-32000 ~ 32000	2	'h0000' or '0'
4	Average processing	channel 0, 2, 3 (weighted, number, time)	3	'h1204' or '4612'
5	Average	Channel 0 weighted average: 50 (%)	4	'h0032' or '50'
6	Average	channel 2 number average: 100 (times)	6	'h0064' or '100'
7	Average	channel 3 time average: 200 (ms)	7	'h00C8' or '200'

(3) Program description

- When the digital value of channel 0 is smaller than 12000, contact point 0 (P00080) of the relay output module mounted in slot 2 is on.
- When the digital value of channel 2 is greater than 13600, contact point 2 (P00082) of the relay output module mounted in slot 2 is on.
- When the digital value of channel 3 is greater than or equal to 12000 and smaller than or equal to 13600, contact point 4 (P00086) of the relay output module mounted in slot 2 is On.
- When the digital value of channel 3 is 13600, contact point 5 (P00085) of the relay output module mounted in slot 2 is on.

(4) Program

(a) An example of the program that uses [I/O parameter] setting

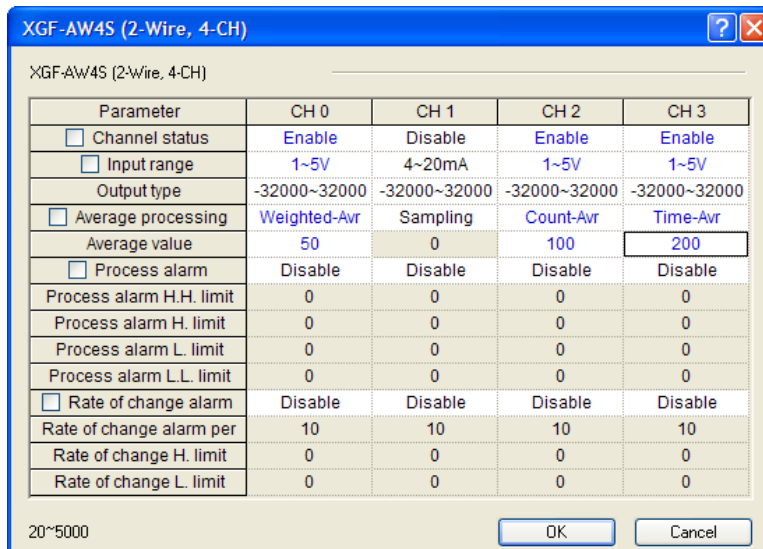
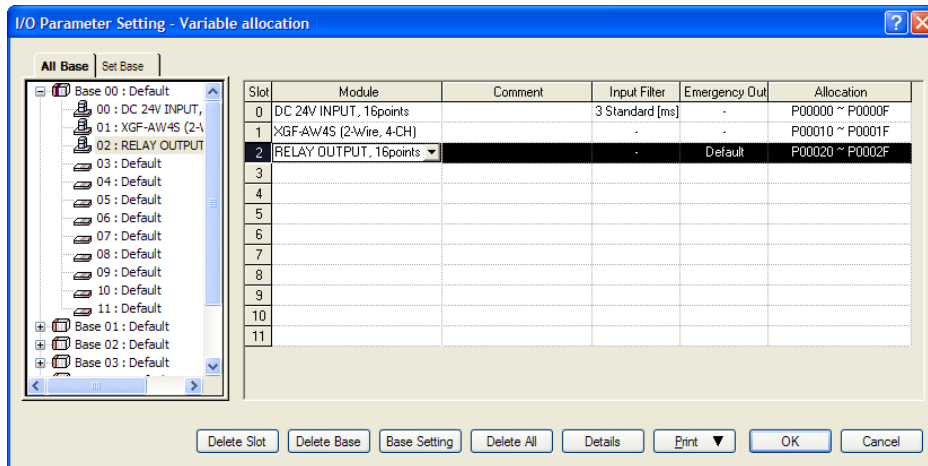
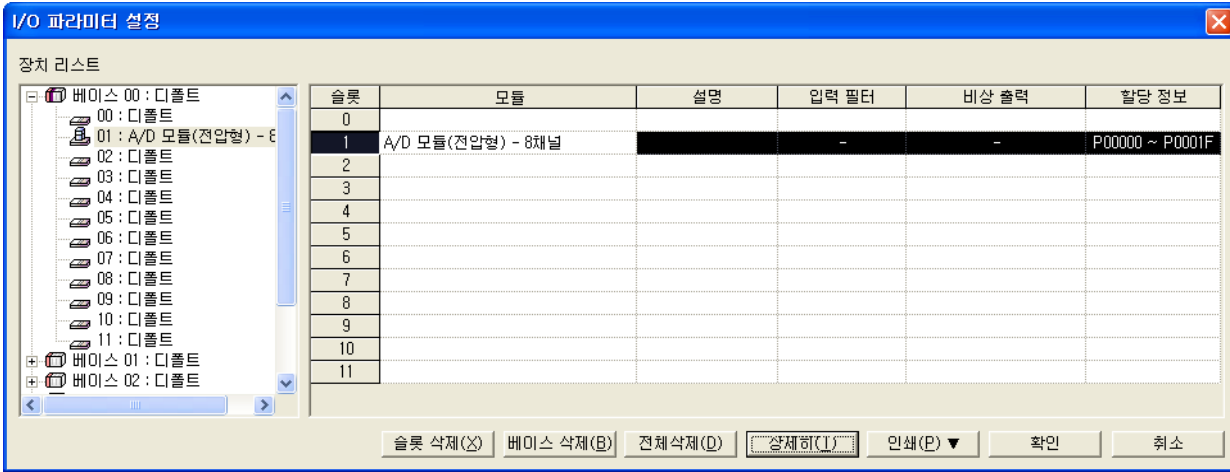

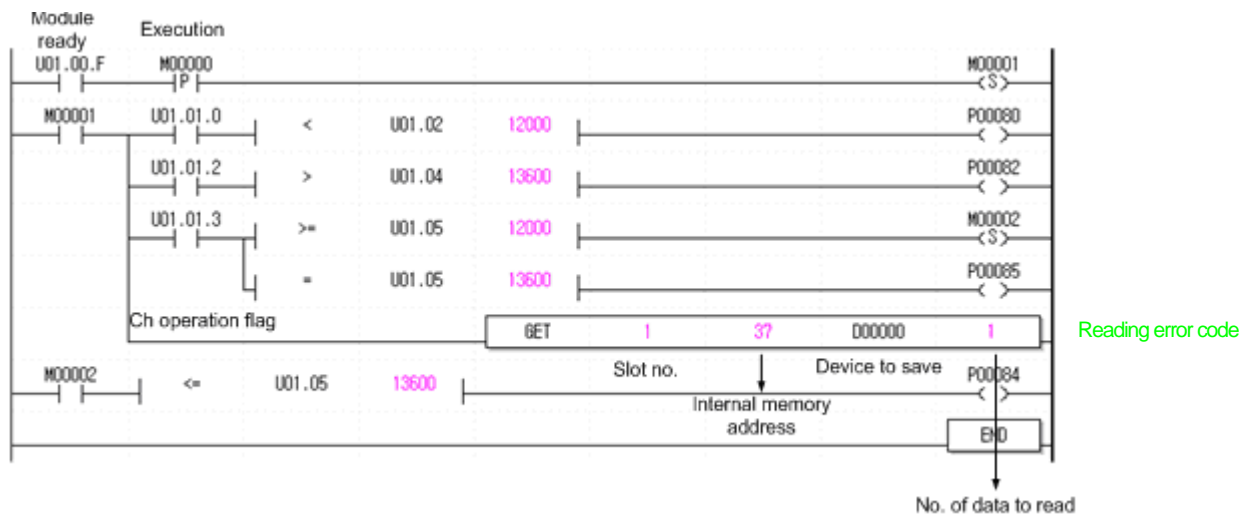

(b) An example of the program that uses PUT/GET command

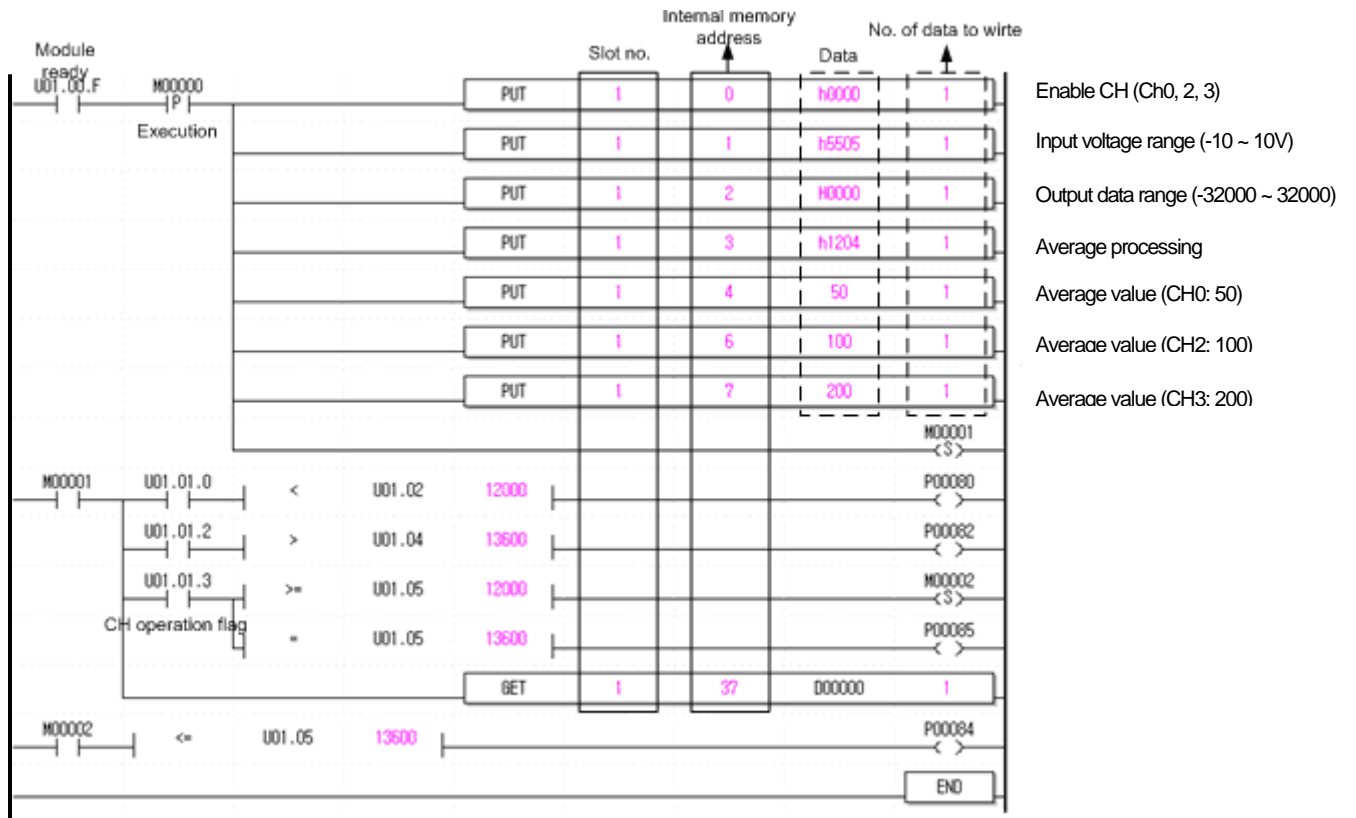

6.3.2 The Program That Outputs the Error Code of the 2 Wire Input Analog Input Module through BCD Display (I/O slot variable point allocation)

(1) System configuration

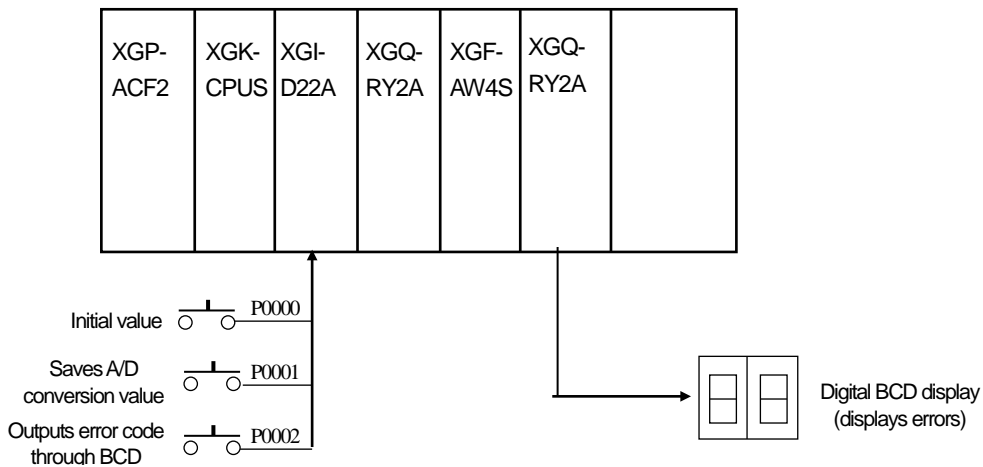

(2) Initial setting

- (a) Channel in use: channel 0
- (b) Analog input current range: DC 4 ~ 20 mA
- (c) Time average processing: 100 (ms)
- (d) Digital output data range: -32000~32000

(3) Program description

- (a) The A/D conversion value and error code are respectively saved in D00000 and D00001 when P00001 is On
- (b) The error code is displayed in the digital BCD display when P00002 is On (P00030 ~ P0003F).

(4) Program

- (a) An example of the program that uses [I/O parameter] setting

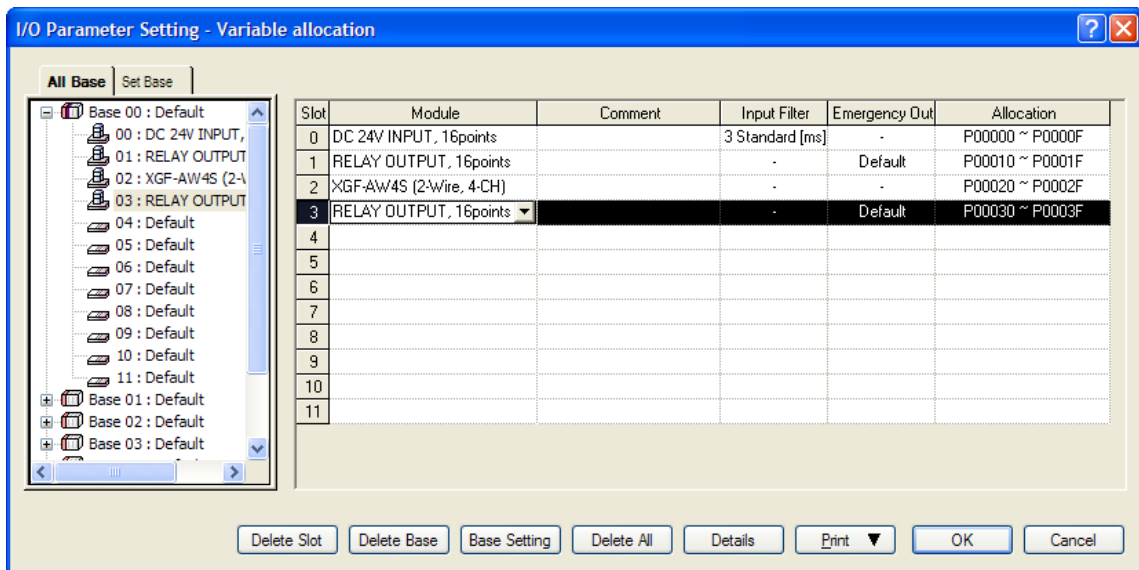

XGF-AW4S (2-Wire, 4-CH)

Parameter	CH 0	CH 1	CH 2	CH 3
<input type="checkbox"/> Channel status	Enable	Disable	Disable	Disable
<input type="checkbox"/> Input range	4~20mA	4~20mA	4~20mA	4~20mA
Output type	-32000~32000	-32000~32000	-32000~32000	-32000~32000
<input type="checkbox"/> Average processing	Time-Avr	Sampling	Sampling	Sampling
Average value	100	0	0	0
<input type="checkbox"/> Process alarm	Disable	Disable	Disable	Disable
Process alarm H.H. limit	0	0	0	0
Process alarm H. limit	0	0	0	0
Process alarm L. limit	0	0	0	0
Process alarm L.L. limit	0	0	0	0
<input type="checkbox"/> Rate of change alarm	Disable	Disable	Disable	Disable
Rate of change alarm per	10	10	10	10
Rate of change H. limit	0	0	0	0
Rate of change L. limit	0	0	0	0

20~5000

OK Cancel

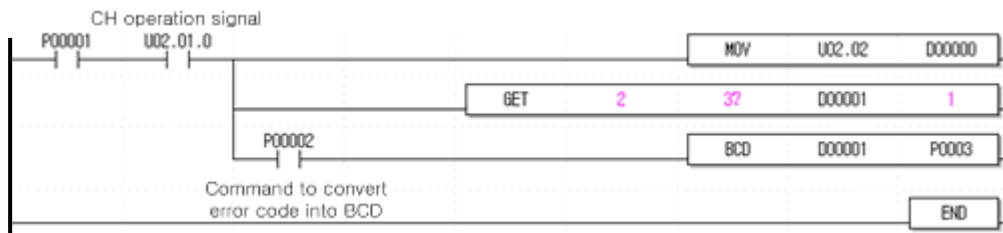

Saves A/D conversion value of CH0 in D0
 Saves error code of CH0 in D1
 Converts data in D1 into BCD and outputs to P30~P3F

(b) An example of the program that uses PUT/GET command

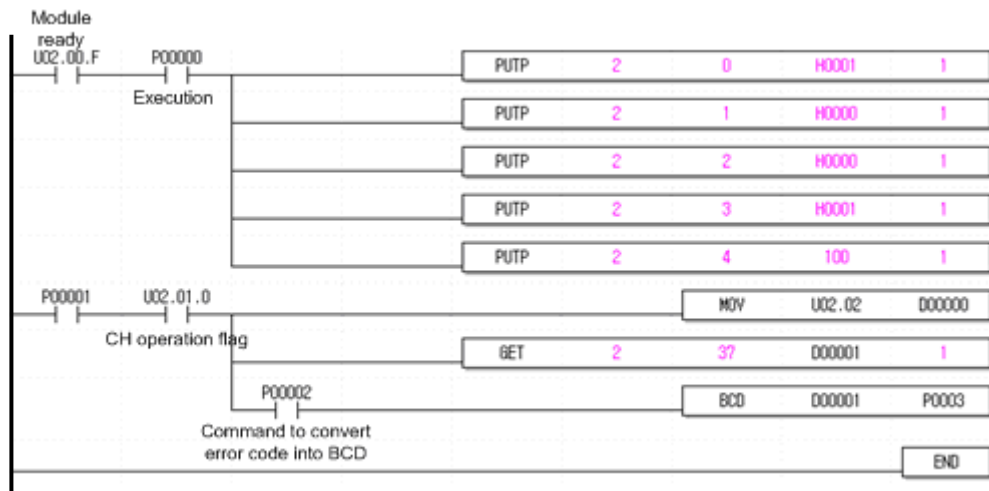

Enable CH (CH0)
 Input current range (4~20mA)
 Output data range (-32000~32000)
 Time average processing (CH0)
 Average value (CH0: 100)
 Saves A/D conversion value of CH0 in D0
 Saves error code of CH0 in D1
 Converts data in D1 into BCD and outputs to P30~P3F

Chapter 7 Configuration and Functions of Global Variable (XGI/XGR)

7.1 Global Variables (Data Areas)

7.1.1 Input and Output Ranges of the 2-Wire Input Analog Input Module

Table 7.1 shows the A/D conversion data input and output ranges.

[Table 7. 1] A/D conversion data input and output ranges

Global variables	Memory allocation	Description	R/W
_xxyy_ERR	%UXxx.yy.0	Module error flag	Read
_xxyy_RDY	%UXxx.yy.15	Module READY flag	
_xxyy_CH0_ACT	%UXxx.yy.16	channel 0 operating flag	Read
_xxyy_CH1_ACT	%UXxx.yy.17	channel 1 operating flag	
_xxyy_CH2_ACT	%UXxx.yy.18	channel 2 operating flag	
_xxyy_CH3_ACT	%UXxx.yy.19	channel 3 operating flag	
_xxyy_CH0_DATA	%UWxx.yy.2	channel 0 digital output value	Read
_xxyy_CH1_DATA	%UWxx.yy.3	channel 1 digital output value	
_xxyy_CH2_DATA	%UWxx.yy.4	channel 2 digital output value	
_xxyy_CH3_DATA	%UWxx.yy.5	channel 3 digital output value	
_xxyy_CH0_PALL	%UXxx.yy.128	channel 0 process alarm further lower limit detection flag (LL)	Read
_xxyy_CH0_PAL	%UXxx.yy.129	channel 0 process alarm lower limit detection flag (L)	
_xxyy_CH0_PAH	%UXxx.yy.130	channel 0 process alarm upper limit detection flag (H)	
_xxyy_CH0_PAHH	%UXxx.yy.131	channel 0 process alarm further upper limit detection flag (HH)	
_xxyy_CH1_PALL	%UXxx.yy.132	channel 1 process alarm further lower limit detection flag (LL)	
_xxyy_CH1_PAL	%UXxx.yy.133	channel 1 process alarm lower limit detection flag (L)	
_xxyy_CH1_PAH	%UXxx.yy.134	channel 1 process alarm upper limit detection flag (H)	
_xxyy_CH1_PAHH	%UXxx.yy.135	channel 1 process alarm further upper limit detection flag (HH)	
_xxyy_CH2_PALL	%UXxx.yy.136	channel 2 process alarm further lower limit detection flag (LL)	
_xxyy_CH2_PAL	%UXxx.yy.137	channel 2 process alarm lower limit detection flag (L)	
_xxyy_CH2_PAH	%UXxx.yy.138	channel 2 process alarm upper limit detection flag (H)	
_xxyy_CH2_PAHH	%UXxx.yy.139	channel 2 process alarm further upper limit detection flag (HH)	
_xxyy_CH3_PALL	%UXxx.yy.140	channel 3 process alarm further lower limit detection flag (LL)	
_xxyy_CH3_PAL	%UXxx.yy.141	channel 3 process alarm lower limit detection flag (L)	
_xxyy_CH3_PAH	%UXxx.yy.142	channel 3 process alarm upper limit detection flag (H)	
_xxyy_CH3_PAHH	%UXxx.yy.143	channel 3 process alarm further upper limit detection flag (HH)	
_xxyy_CH0_RAL	%UXxx.yy.144	channel 0 change rate alarm lower limit detection flag (L)	
_xxyy_CH0_RAH	%UXxx.yy.145	channel 0 change rate alarm upper limit detection flag (H)	
_xxyy_CH1_RAL	%UXxx.yy.146	channel 1 change rate alarm lower limit detection flag (L)	
_xxyy_CH1_RAH	%UXxx.yy.147	channel 1 change rate alarm upper limit detection flag (H)	
_xxyy_CH2_RAL	%UXxx.yy.148	channel 2 change rate alarm lower limit detection flag (L)	
_xxyy_CH2_RAH	%UXxx.yy.149	channel 2 change rate alarm upper limit detection flag (H)	
_xxyy_CH3_RAL	%UXxx.yy.150	channel 3 change rate alarm lower limit detection flag (L)	
_xxyy_CH3_RAH	%UXxx.yy.151	channel 3 change rate alarm upper limit detection flag (H)	

Global variables	Memory allocation	Description	R/W
_xxyy_CH0_IDD	%UXxx.yy.160	channel 0 disconnection detection flag (1 ~ 5V or 4 ~ 20mA)	Read
_xxyy_CH1_IDD	%UXxx.yy.161	channel 1 disconnection detection flag (1 ~ 5V or 4 ~ 20mA)	
_xxyy_CH2_IDD	%UXxx.yy.162	channel 2 disconnection detection flag (1 ~ 5V or 4 ~ 20mA)	
_xxyy_CH3_IDD	%UXxx.yy.163	channel 3 disconnection detection flag (1 ~ 5V or 4 ~ 20mA)	
_xxyy_ERR_CLR	%UXxx.yy.176	Error clear request flag	Write

※ Base number yy means the number of the slot where the module is mounted and xx the number of the base where the module is mounted.

(1) The channel 1 digital output value of Analog input module mounted in base 0 slot 4 is expressed as %UW0.4.3.

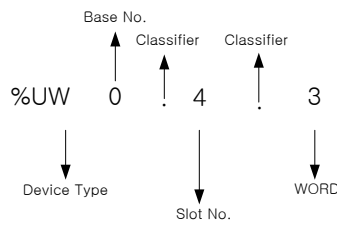

(2) The channel 3 disconnection detection flag of Analog input module mounted in base 0 slot 5 is expressed as %UX0.5.163.

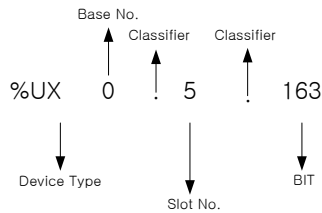

7.1.2 How to Use Global Variables

- You can register the global variables either by automatic registration after setting I/O parameters in the project window or registering them simultaneously after setting the I/O parameters.

(1) I/O parameter registration

- You can register the module you want to use in I/O parameter.

(a) Double click on the I/O parameter in the project window.

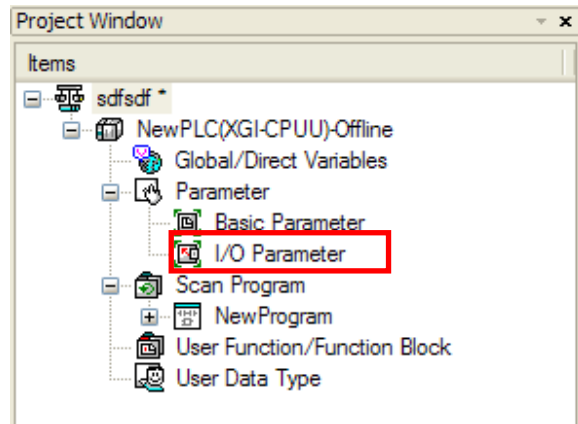

(b) Select XGF-AD8A module in the I/O parameter window.

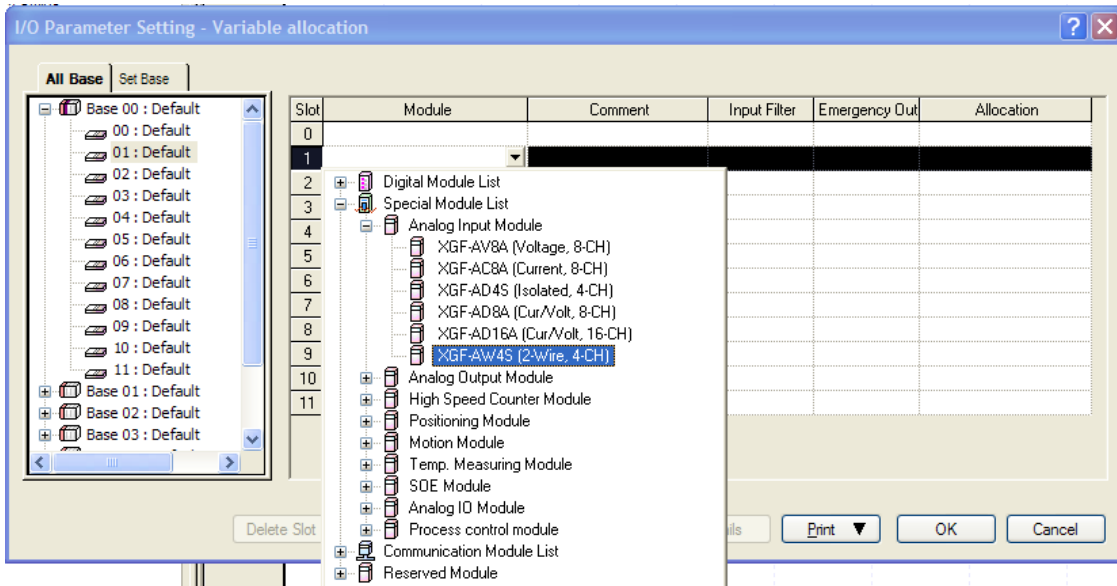

(c) Press the [Detail] button, set the parameter and choose OK.

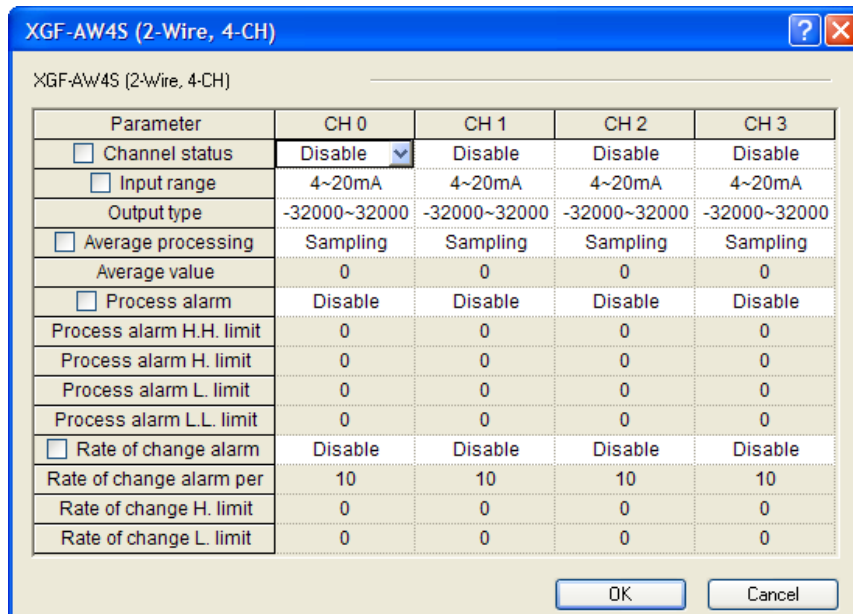

(d) Select [Y].

- The global variable of the module set in I/O parameter is automatically registered.

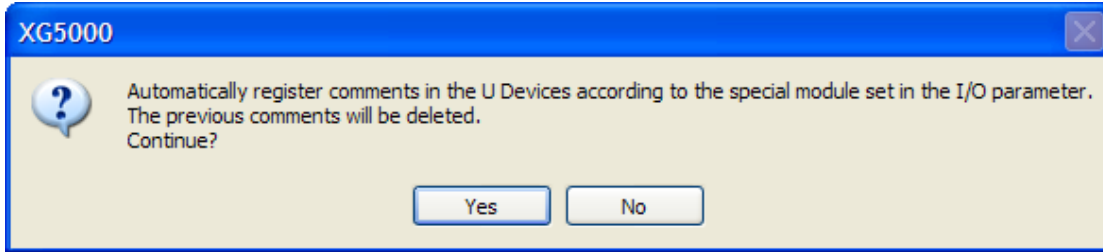

(e) Checking the automatic registration of the global variables

- Double-click on the global/direct variables in the project window.

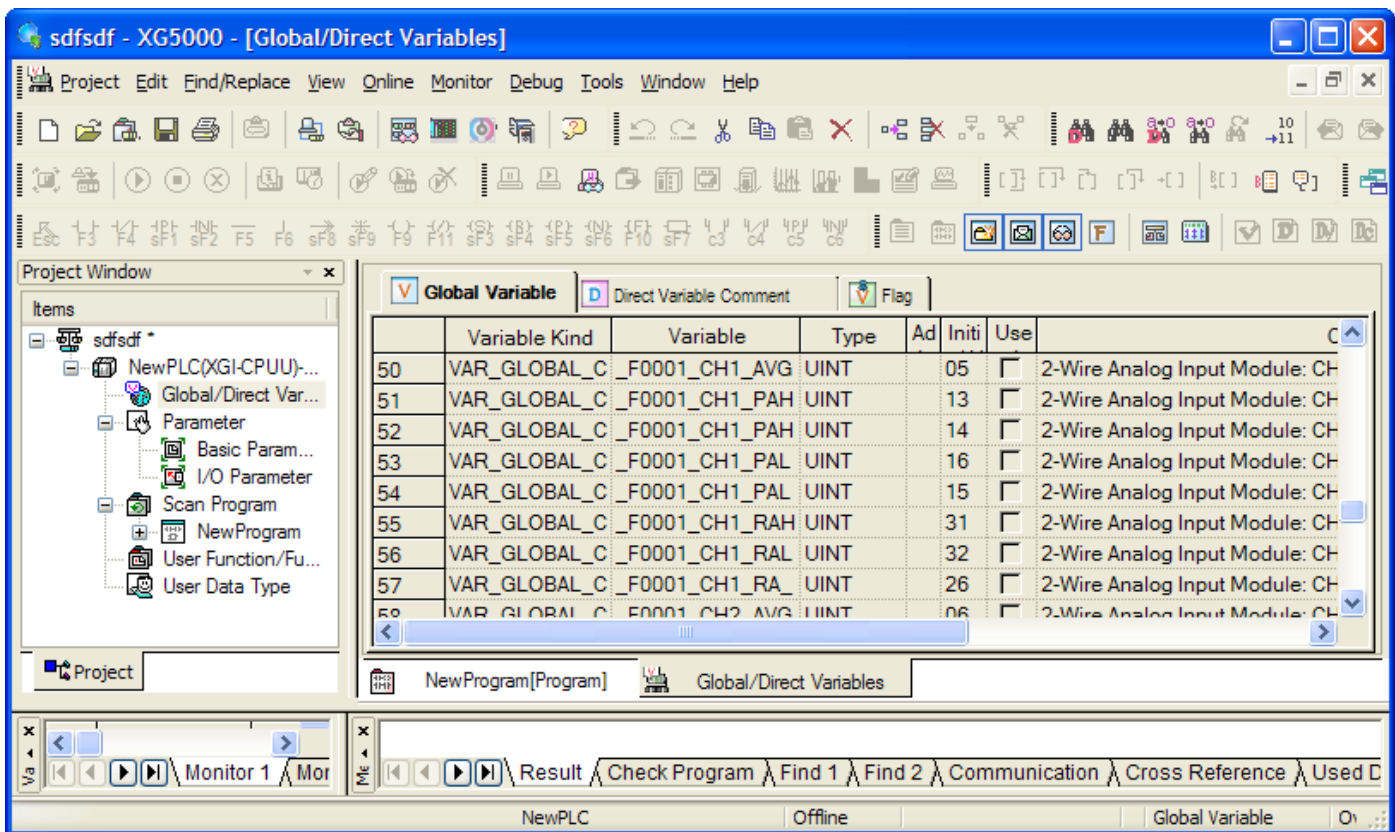
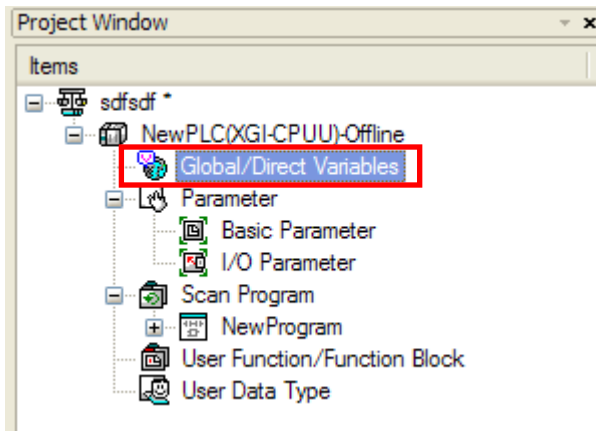

(3) Local variables registration

- You can register the registered global variables that you want to use as the local variables.

- (a) Double-click on the local variables of the program where you want to use the global variables in the scan program below.
- (b) Press the right button of the mouse in the right local variable window and select “Add external variable.”

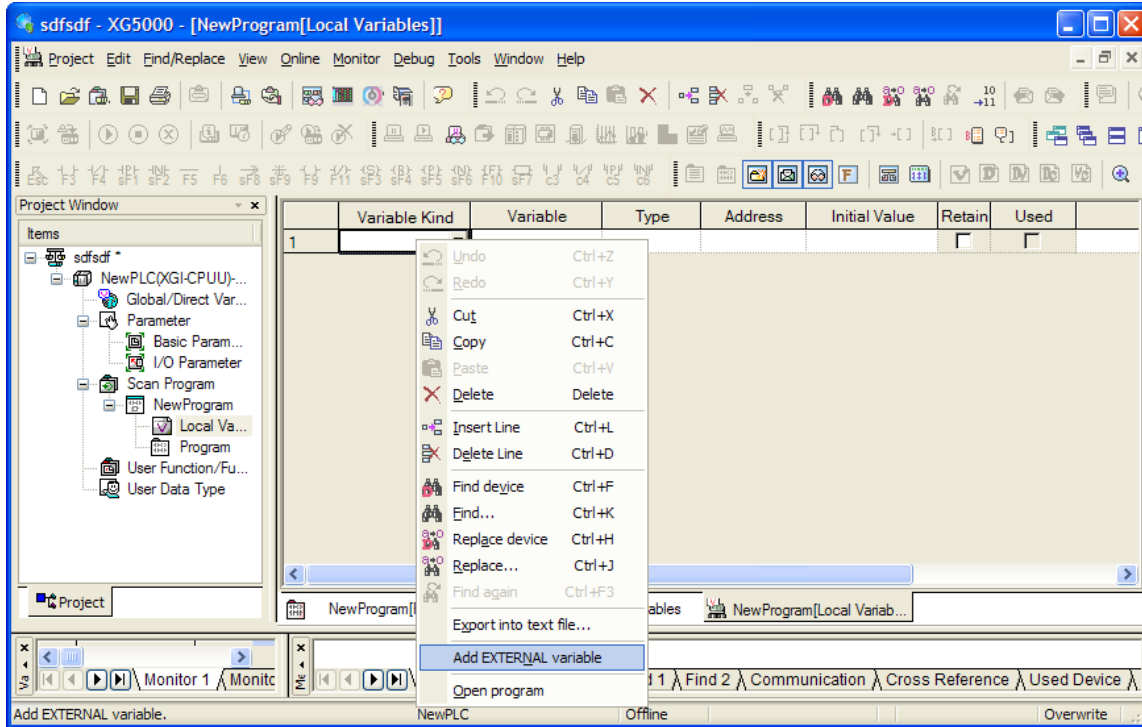

- (c) Select “all” or “base slot” in View global variables for the local variables that you want to add in the “External variable add window” below.

- View all

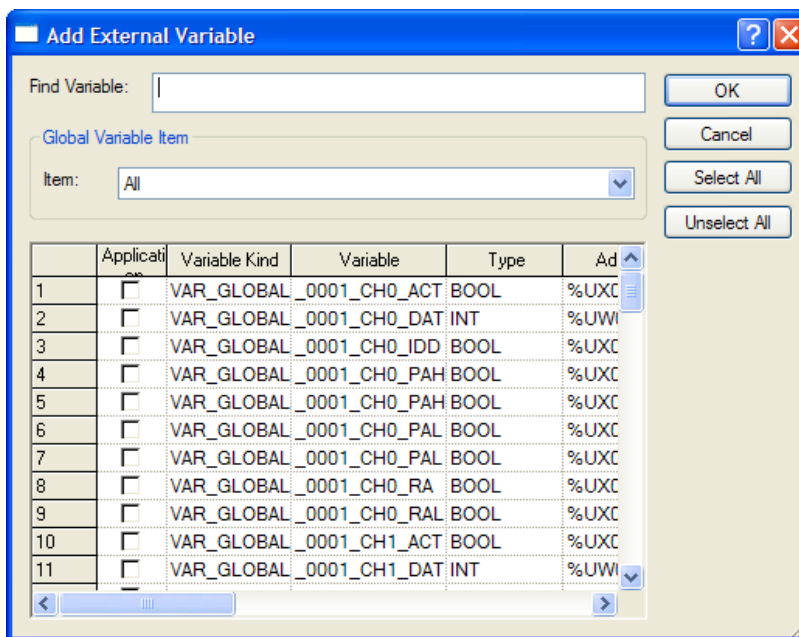

- View each base slot

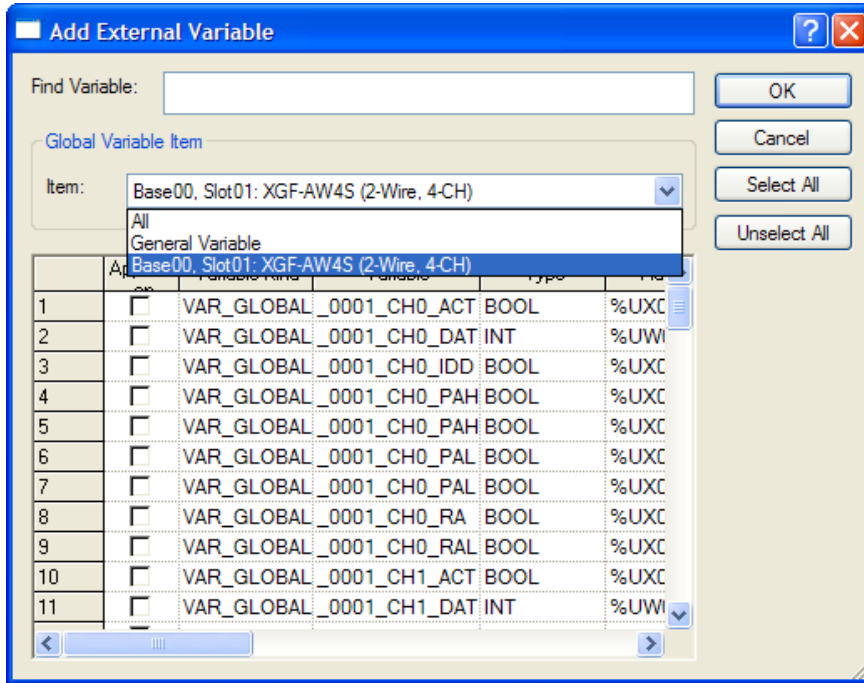

(d) The following is an example that the digital input value (_0000_CH0_DATA) of "base00 slot00" in View global variables.

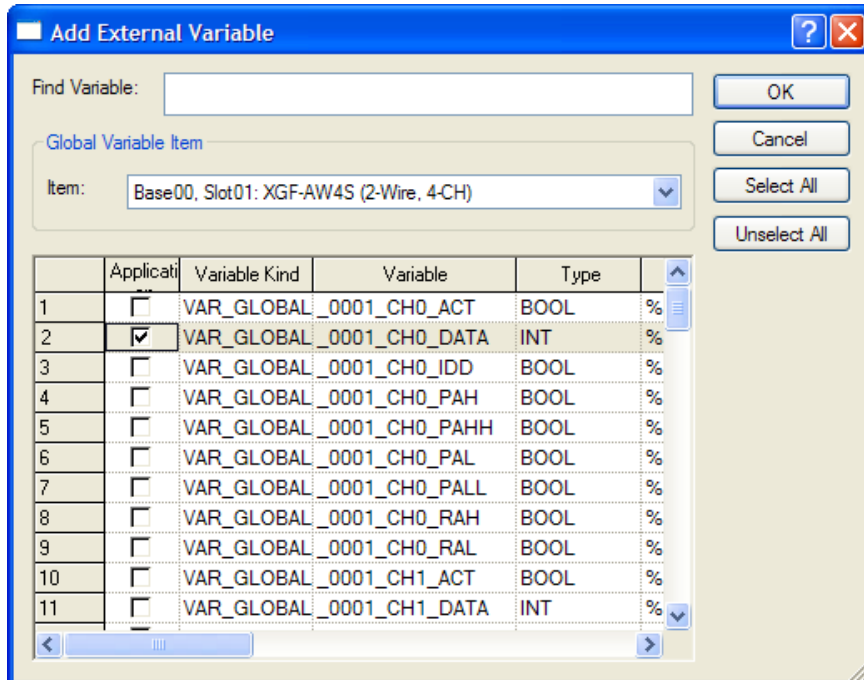

(4) How to use local variables in the program

- This section describes how to use the added global variables in the local program.
- The following is an example in which the conversion value of channel 0 of the Analog input module is brought to %MW0.

(a) Double click on the variable before IN in the area where the A/D conversion data is read as %MW0 by using the MOVE function below and invoke the variable selection window.

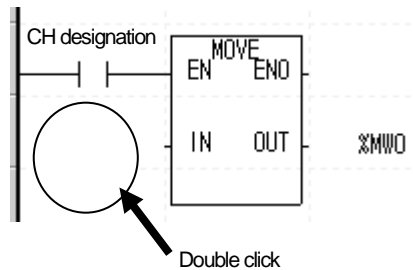

(b) Choose the global variable as the variable type in the variable selection window and then the corresponding base in the View global variable item (base 0, slot 1).

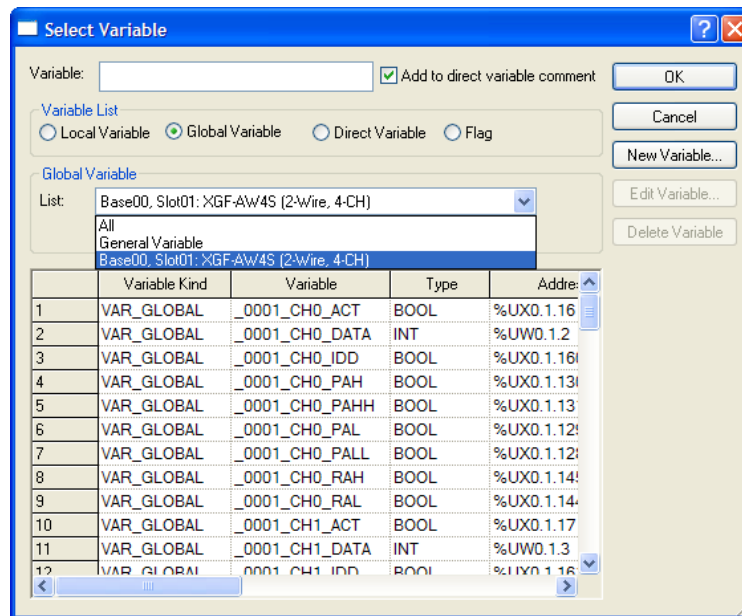

(c) Double-click on _0000_CH0_DATA that corresponds to the A/D conversion data of channel 0 and click on [OK].

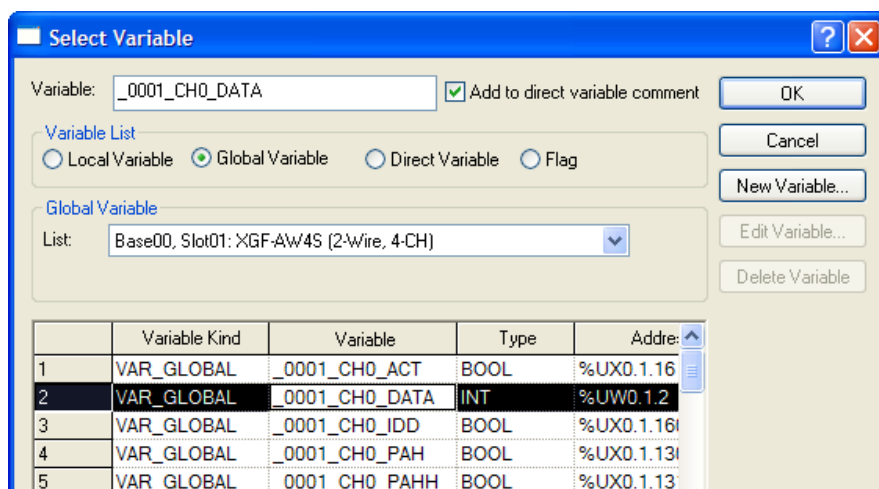

(d) The following is the result of adding the global variable corresponding to the A/D conversion data of channel 0.

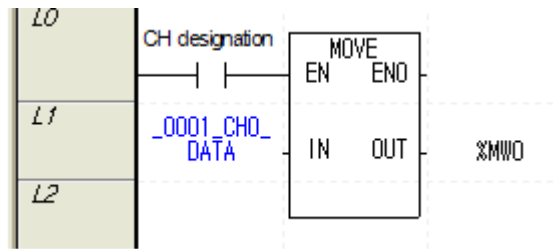

7.2 PUT/GET Function Block Ranges (Parameter Area)

7.2.1 PUT/GET Function Block Ranges (Parameter Area)

Table 7.2 shows the operating parameter setting ranges of the 2 lint input analog input module.

[Table 7. 2] Operating parameter setting ranges

Global variables	Designation	R/W	Command
_Fxyy_ALM_EN _Fxyy_AVG_SEL _Fxyy_CH_EN	Alarm processing Average processing method Channel to use	RW	PUT
_Fxyy_CH0_AVG_VAL _Fxyy_CH0_PAH_VAL _Fxyy_CH0_PAHH_VAL _Fxyy_CH0_PAL_VAL _Fxyy_CH0_PALL_VAL _Fxyy_CH0_RA_PERIOD _Fxyy_CH0_RAH_VAL _Fxyy_CH0_RAL_VAL	channel 0 average channel 0 process alarm upper limit set value channel 0 process alarm further upper limit set value channel 0 process alarm lower limit set value channel 0 process alarm further lower limit set value channel 0 change rate alarm detection cycle channel 0 change rate alarm upper limit set value channel 0 change rate alarm lower limit set value	RW	PUT
_Fxyy_CH1_AVG_VAL _Fxyy_CH1_PAH_VAL _Fxyy_CH1_PAHH_VAL _Fxyy_CH1_PAL_VAL _Fxyy_CH1_PALL_VAL _Fxyy_CH1_RA_PERIOD _Fxyy_CH1_RAH_VAL _Fxyy_CH1_RAL_VAL	channel 1 average channel 1 process alarm upper limit set value channel 1 process alarm further upper limit set value channel 1 process alarm lower limit set value channel 1 process alarm further lower limit set value channel 1 change rate alarm detection cycle channel 1 change rate alarm upper limit set value channel 1 change rate alarm lower limit set value	RW	PUT
_Fxyy_CH2_AVG_VAL _Fxyy_CH2_PAH_VAL _Fxyy_CH2_PAHH_VAL _Fxyy_CH2_PAL_VAL _Fxyy_CH2_PALL_VAL _Fxyy_CH2_RA_PERIOD _Fxyy_CH2_RAH_VAL _Fxyy_CH2_RAL_VAL	channel 2 average channel 2 process alarm upper limit set value channel 2 process alarm further upper limit set value channel 2 process alarm lower limit set value channel 2 process alarm further lower limit set value channel 2 change rate alarm detection cycle channel 2 change rate alarm upper limit set value channel 2 change rate alarm lower limit set value	RW	PUT
_Fxyy_CH3_AVG_VAL _Fxyy_CH3_PAH_VAL _Fxyy_CH3_PAHH_VAL _Fxyy_CH3_PAL_VAL _Fxyy_CH3_PALL_VAL _Fxyy_CH3_RA_PERIOD _Fxyy_CH3_RAH_VAL _Fxyy_CH3_RAL_VAL	channel 3 average channel 3 process alarm upper limit set value channel 3 process alarm further upper limit set value channel 3 process alarm lower limit set value channel 3 process alarm further lower limit set value channel 3 change rate alarm detection cycle channel 3 change rate alarm upper limit set value channel 3 change rate alarm lower limit set value	RW	PUT
_Fxyy_DATA_TYPE _Fxyy_IN_RANGE	Output data type Input current/voltage ranges	RW	PUT
_Fxyy_ERR_CODE	Error code	R	GET

※ In device allocation, xx and yy respectively mean the numbers of the base and slot where the module is mounted.

7.2.2 PUT/GET Commands

(1) PUT Command

PUT
Write data in special module

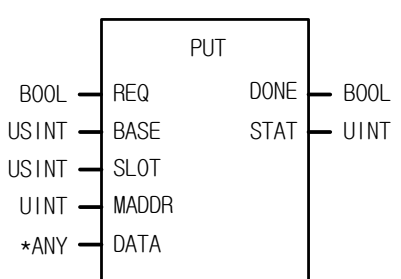
Function block	Description
	<p>Input</p> <p>REQ : performs function when 1 BASE : designates base location SLOT : designates slot location MADDR : module address DATA : data to save in module</p> <p>Output</p> <p>DONE : outputs 1 when normally functioning STAT : error information</p>

*ANY: WORD, DWORD, INT, USINT, DINT, UDINT types are available of ANY types.

■ Function

Reads data from the designated special module

Function block	ANY type	Function
PUT_WORD	WORD	Saves WORD data in the designated module address (MADDR).
PUT_DWORD	DWORD	Saves DWORD data in the designated module address (MADDR).
PUT_INT	INT	Saves INT data in the designated module address (MADDR).
PUT_UINT	UINT	Saves UINT data in the designated module address (MADDR).
PUT_DINT	DINT	Saves DINT data in the designated module address (MADDR).
PUT_UDINT	UDINT	Saves UDINT data in the designated module address (MADDR).

(2) GET command

GET
Read data in special module

Function block	Description
	<p>Input</p> <p>REQ : performs function when 1</p> <p>BASE : designates base location</p> <p>SLOT : designates slot location</p> <p>MADDR : module address 512(0x200) ~ 1023(0x3FF)</p> <p>Output</p> <p>DONE : outputs 1 when normally functioning</p> <p>STAT : error information</p> <p>DATA : data read from module</p>

*ANY: WORD, DWORD, INT, USINT, DINT, UDINT types are available of ANY types.

■ **Function**

Reads data from the designated special module

Function block	ANY type	Function
GET_WORD	WORD	Reads WORD data from the designated module address (MADDR).
GET_DWORD	DWORD	Reads DWORD data from the designated module address (MADDR).
GET_INT	INT	Reads INT data from the designated module address (MADDR).
GET_UINT	UINT	Reads UINT data from the designated module address (MADDR).
GET_DINT	DINT	Reads DINT data from the designated module address (MADDR).
GET_UDINT	UDINT	Reads UDINT data from the designated module address (MADDR).

7.2.3 Examples of Use of PUT/GET Commands

(1) Designation of channel to use

- (a) You can set Allow/block of A/D conversion for each channel.
- (b) You can shorten the conversion cycle for each channel by blocking conversion of the unused channel.
- (c) When no channel is designated for use, all channels are blocked from use.
- (d) Allow/block of A/D conversion is as follows.

B15	B14	B13	B12	B11	B10	B9	B8	B7	B6	B5	B4	B3	B2	B1	B0
—	—	—	—	—	—	—	—	—	—	—	—	C	C	C	C
—	—	—	—	—	—	—	—	—	—	—	—	H	H	H	H
												3	2	1	0

Bit	Description
0	Stop
1	Operating

16#0003 : 0000 0000 0000 0011
 ↓
 channel 3,channel 2,channel 1,channel 0

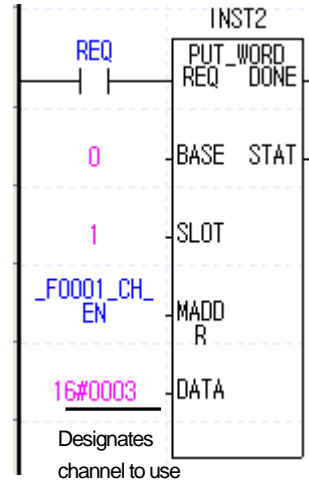

- (e) The values set between B4 ~ B15 will be ignored.
- (f) The illustration on the right side is an example of designating channels 0~1 as the use channel of the analog input module.

(2) Designation of Input Voltage/Current Ranges

- (a) You can designate the analog input voltage/current ranges for each channel.
- (b) When no analog input range is designated, all channels are set as 1 ~ 5 V (4 ~ 20 mA).
- (c) The setting of analog input voltage/current ranges is as follows.

- The following example is when channels 0~1 are 4~20 mA and channels 2~3 are 1~5V.

B15	B14	B13	B12	B11	B10	B9	B8	B7	B6	B5	B4	B3	B2	B1	B0
Channel 3				Channel 2				Channel 1				Channel 0			

BIT	Ranges
0000	4 mA ~ 20 mA
0001	1 V ~ 5 V

16#1100 : 0001 0001 0000 0000
 channel 3,channel 2,channel 1,channel 0

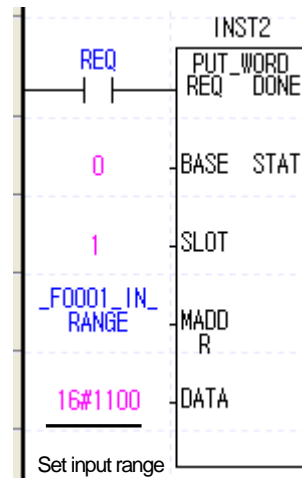

(3) Output data range setting

- (a) You can designate the digital output data ranges for analog input for each channel.
- (b) When no analog input range is designated, all channels are set as -32000~32000.
- (c) The setting of digital output data ranges is as follows.

B15	B14	B13	B12	B11	B10	B9	B8	B7	B6	B5	B4	B3	B2	B1	B0
Channel 3				Channel 2				Channel 1				Channel 0			
BIT		Ranges													
0000		-32000 ~ 32000													
0001		Precise Value													
0010		0 ~ 10000													

16#2012 : 0010 0000 0001 0010
 channel 3,channel 2,channel 1,channel 0

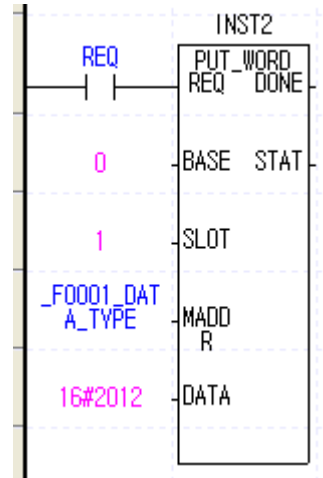

The precise value has the following digital output ranges for the analog input range.

1) Current

Analog input	4 ~ 20 mA
Digital output	
Precise Value	4000 ~ 20000

2) Voltage

Analog input	1 ~ 5 V
Digital output	
Precise Value	1000 ~ 5000

(4) Designation of filtering

- (a) You can set Allow/block of filtering for each channel.
- (b) When no filtering is designated, all channels conduct sampling processing.
- (c) The designation of filtering is as follows.
- (d) The following illustration is an example when time average is used for channel 1.

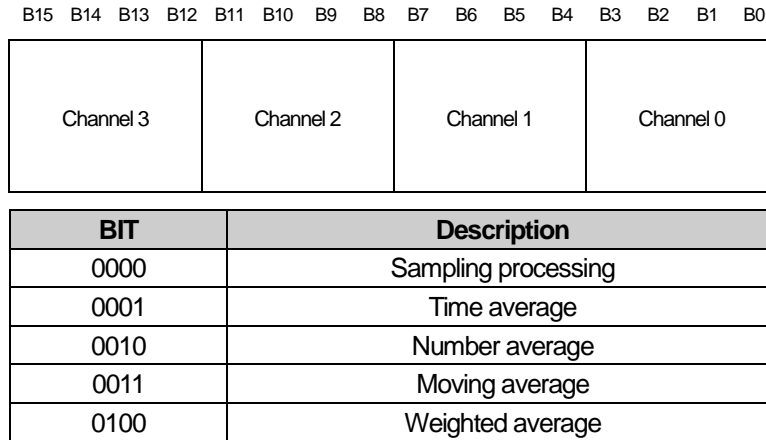

16#0010 : 0000 0000 0001 0000

channel 3,channel 2,channel 1,channel 0

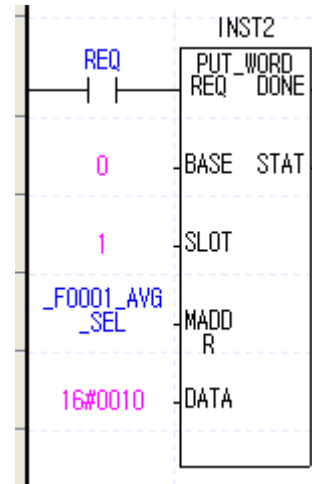

(5) Designation of average values

- (a) The initial value of the average designation range is 0.
- (b) The setting range of the average designation is as follows.

Average	Range
Time average	20 ~ 5000(ms)
Number average	2 ~ 500(times)
Moving average	2 ~ 100(times)
Weighted average	0 ~ 99(%)

(c) When a value beyond the range is designated, the error number is displayed in the error code display (`_F0001_ERR_CODE`).

Then the A/D conversion value remains the previous data. (# refers to the channel where the error occurred)

(d) The setting of the average is as follows.

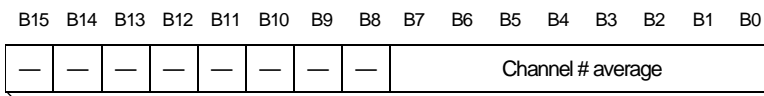

Average range differs to the method.

Variables	Description
<code>_Fxyy_CH0_AVG_VAL</code>	Sets the average of channel 0
<code>_Fxyy_CH1_AVG_VAL</code>	Sets the average of channel 1
<code>_Fxyy_CH2_AVG_VAL</code>	Sets the average of channel 2
<code>_Fxyy_CH3_AVG_VAL</code>	Sets the average of channel 3

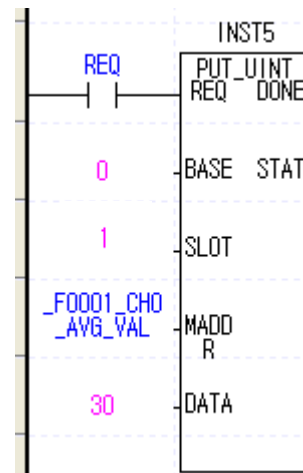

※ In device allocation, x and y respectively mean the numbers of the base and slot where the module is mounted.

Note

When you designate the time/number average processing values, set average processing as 'Allow' in advance. As for average processing, choose between time average and number average.

(6) Alarm processing designation

- (a) You can set Allow/block of filtering for each channel.
- (b) The initial value of the range is 0.
- (c) The designation of alarm processing is as follows.

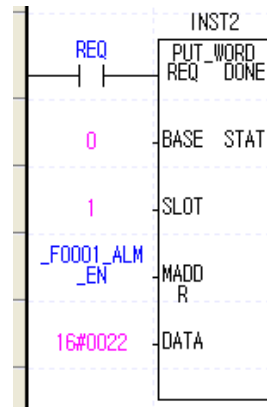
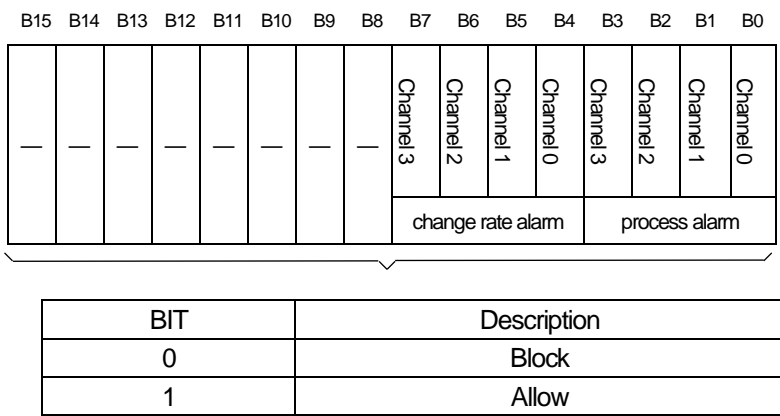

(7) Designation of process alarm setting values

- (a) This is the area where you designate the process alarm setting value for each channel. The setting ranges differs according to the range of the output data.

- 1) Signed value: -32768 ~ 32767
- 2) Precise value

Range	Values
4 ~ 20 mA	3808 ~ 20192
1 ~ 5 V	952 ~ 5048

- 3) Percentile value: -120 ~ 10120

- (b) For details, see 2.5.2.

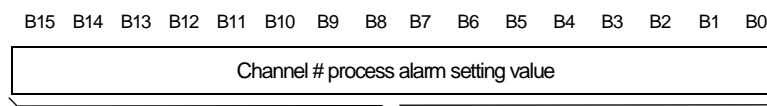

Variables	Description
_F0001_CH0_PAHH_VAL	channel 0 process alarm further upper limit(HH) set value
_F0001_CH0_PAH_VAL	channel 0 process alarm upper limit(H) set value
_F0001_CH0_PAL_VAL	channel 0 process alarm lower limit(L) set value
_F0001_CH0_PALL_VAL	channel 0 process alarm further lower limit(LL) set value
_F0001_CH1_PAHH_VAL	channel 1 process alarm further upper limit(HH) set value
_F0001_CH1_PAH_VAL	channel 1 process alarm upper limit(H) set value
_F0001_CH1_PAL_VAL	channel 1 process alarm lower limit(L) set value
_F0001_CH1_PALL_VAL	channel 1 process alarm further lower limit(LL) set value
_F0001_CH2_PAHH_VAL	channel 2 process alarm further upper limit(HH) set value
_F0001_CH2_PAH_VAL	channel 2 process alarm upper limit(H) set value
_F0001_CH2_PAL_VAL	channel 2 process alarm lower limit(L) set value
_F0001_CH2_PALL_VAL	channel 2 process alarm further lower limit(LL) set value
_F0001_CH3_PAHH_VAL	channel 3 process alarm further upper limit(HH) set value
_F0001_CH3_PAH_VAL	channel 3 process alarm upper limit(H) set value
_F0001_CH3_PAL_VAL	channel 3 process alarm lower limit(L) set value
_F0001_CH3_PALL_VAL	channel 3 process alarm further lower limit(LL) set value

Note
 Before you designate the process alarm set value, set process alarm processing at Allow.

(8) Designation of the change rate alarm detection cycle

- (a) The range of the change rate alarm detection cycle is 10 ~ 5000(ms).
- (b) If you enter a value beyond the range, error code 60# is displayed in the error code display address. Then the change rate alarm detection cycle is calculated with the initial value (10) applied.
- (c) The designation of the change rate alarm detection cycle is as follows.

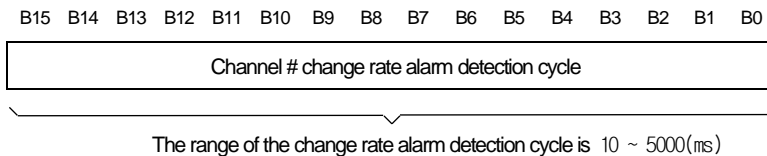

Variables	Description
_F0001_CH0_RA_PERIOD	Channel 0 change rate alarm detection cycle
_F0001_CH1_RA_PERIOD	Channel 1 change rate alarm detection cycle
_F0001_CH2_RA_PERIOD	Channel 2 change rate alarm detection cycle
_F0001_CH3_RA_PERIOD	Channel 3 change rate alarm detection cycle

Note
 Before you designate the change rate alarm detection cycle, set change rate alarm processing at Allow.
 Also, designate the change rate alarm upper limit/lower limit.

(10) Error code

- (a) Saves the error code detected Analog input module.
- (b) The types and descriptions of errors are as follows.
- (c) The following illustration is an example of reading the error code.

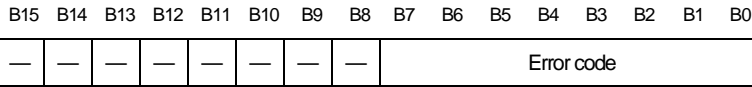

Error code (Decimal)	Description of the error	Note
0	Normal operation	RUN LED on
10	Module error (ASIC Reset Error)	RUN LED flashes every 0.2 second
11	Module error (ASIC RAM or Register Error)	
20#	Beyond the time average setting range	RUN LED flashes every second
30#	Beyond the number average setting range	
40#	Beyond the moving average setting range	
50#	Beyond the weighted average setting range	
60#	Change rate alarm detection cycle setting range exceeded	
80#	4~20mA range offset/gain error	
81#	1~5V range offset/gain error	

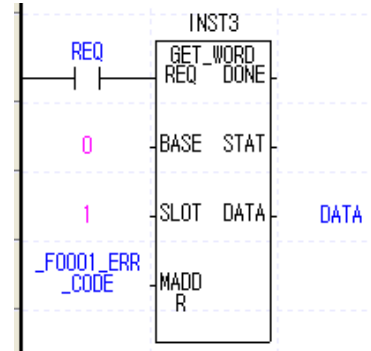

- ※ # of the error code means the channel where the error occurred.
- ※ For details of the error codes, see 9.1.

- (d) If there are two or more errors, the module saves the error code that happened first and does not save the following error codes.
- (e) If there is an error, you should use the error clear request flag (see 5.2.5) or turn the power supply Off → On after the error is corrected so that the LED stops flashing and the error code is deleted.

Chapter 8 Programming (XGI/XGR)

8.1 The Basic Program

8.1.1 Basic program of XGF-AW4S

- This chapter provides information on how to set the operating conditions for the internal memory of the Analog input module.
- The Analog input module is mounted in slot 1.
- The input and output occupancy point of the Analog input module is 16 points (variable).
- The initial setting condition is one time entry. The setting of the initial value is saved in the internal memory of the Analog input module.

(1) An Example of a Program That Uses [I/O Parameter]

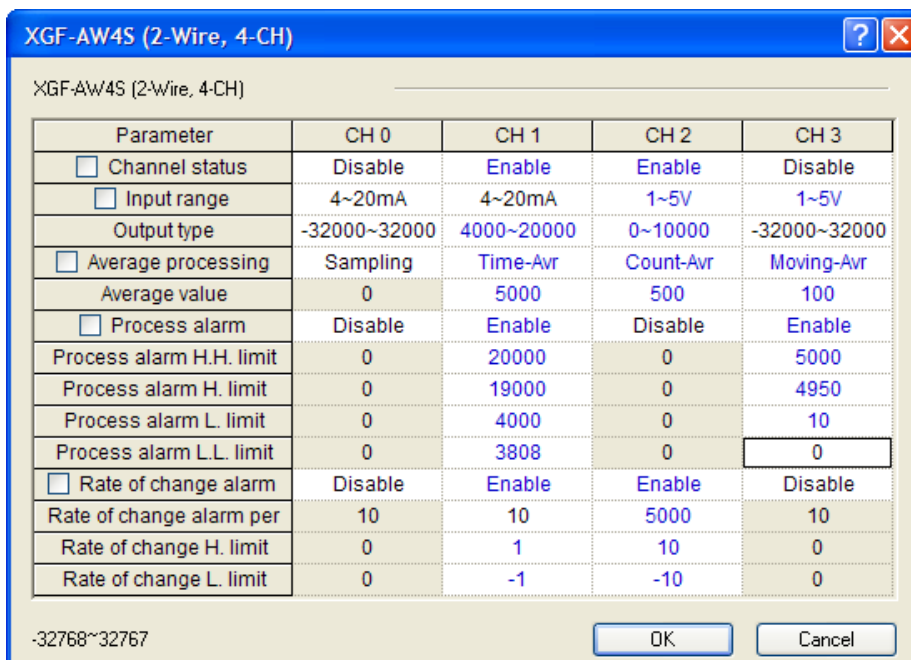
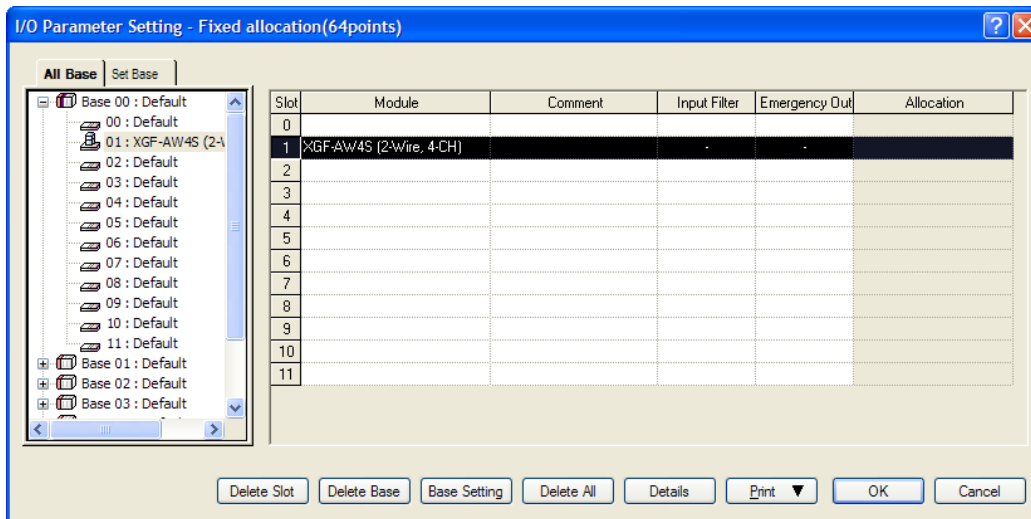

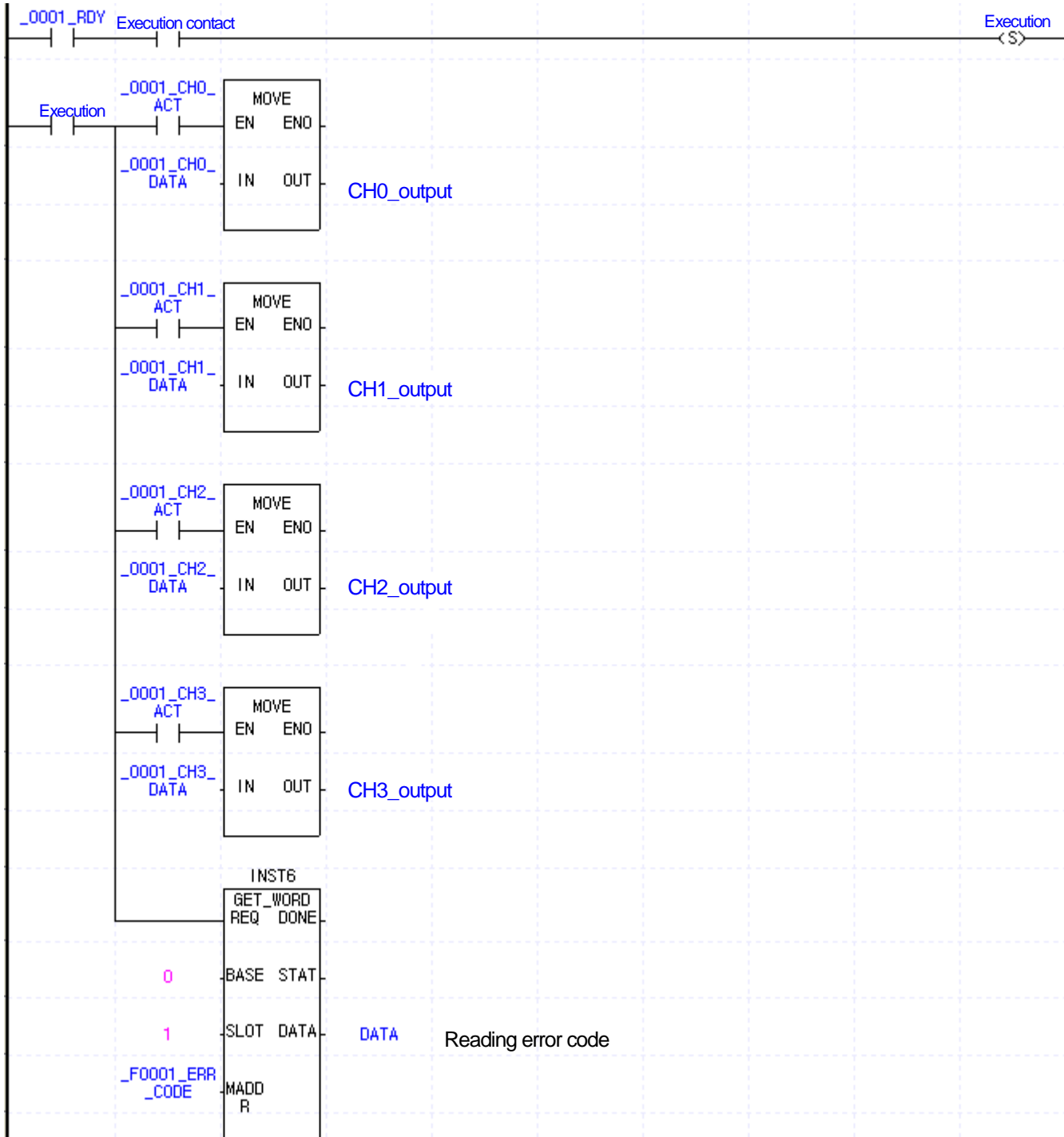

(2) An example of a program that uses the PUT/GET command

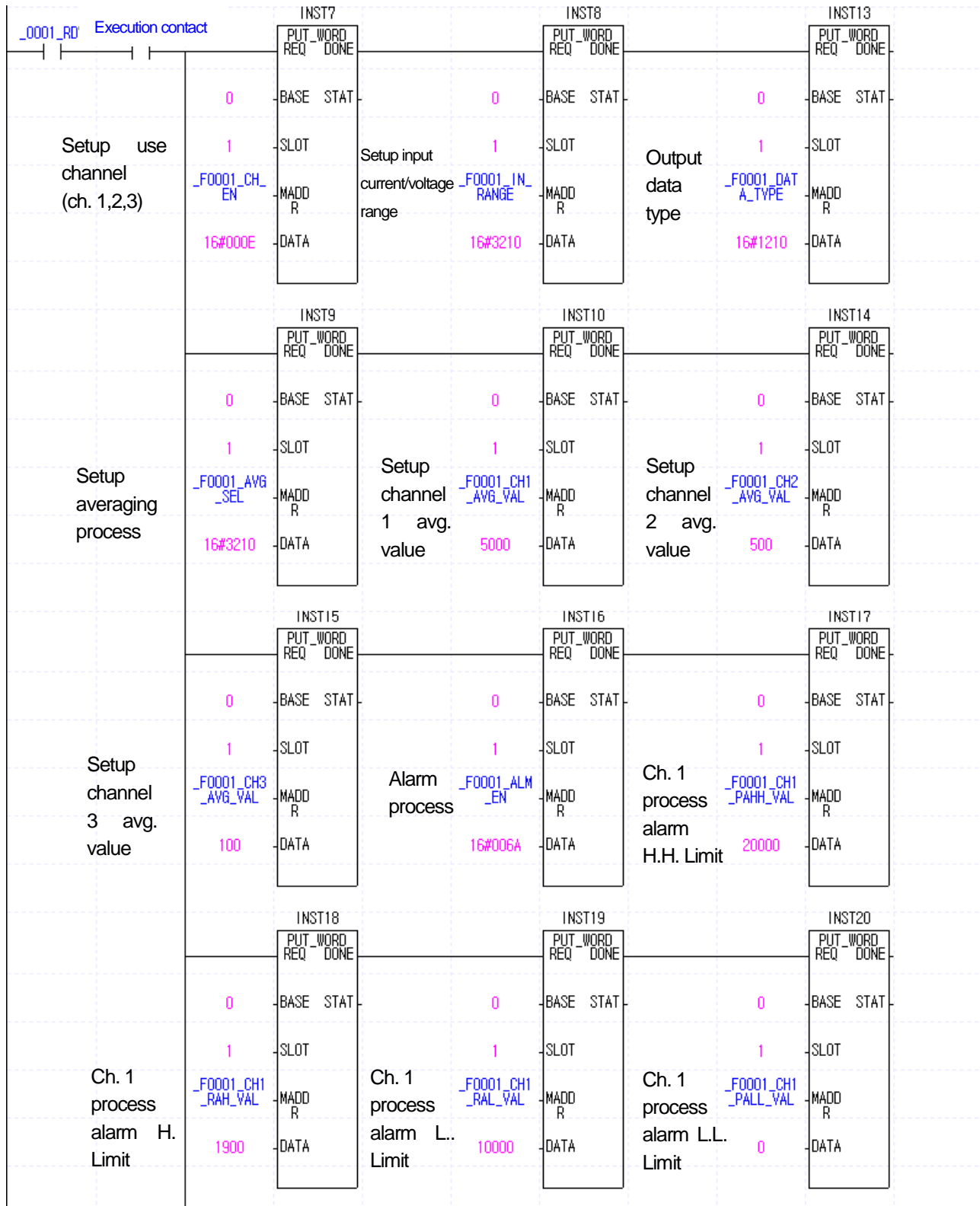

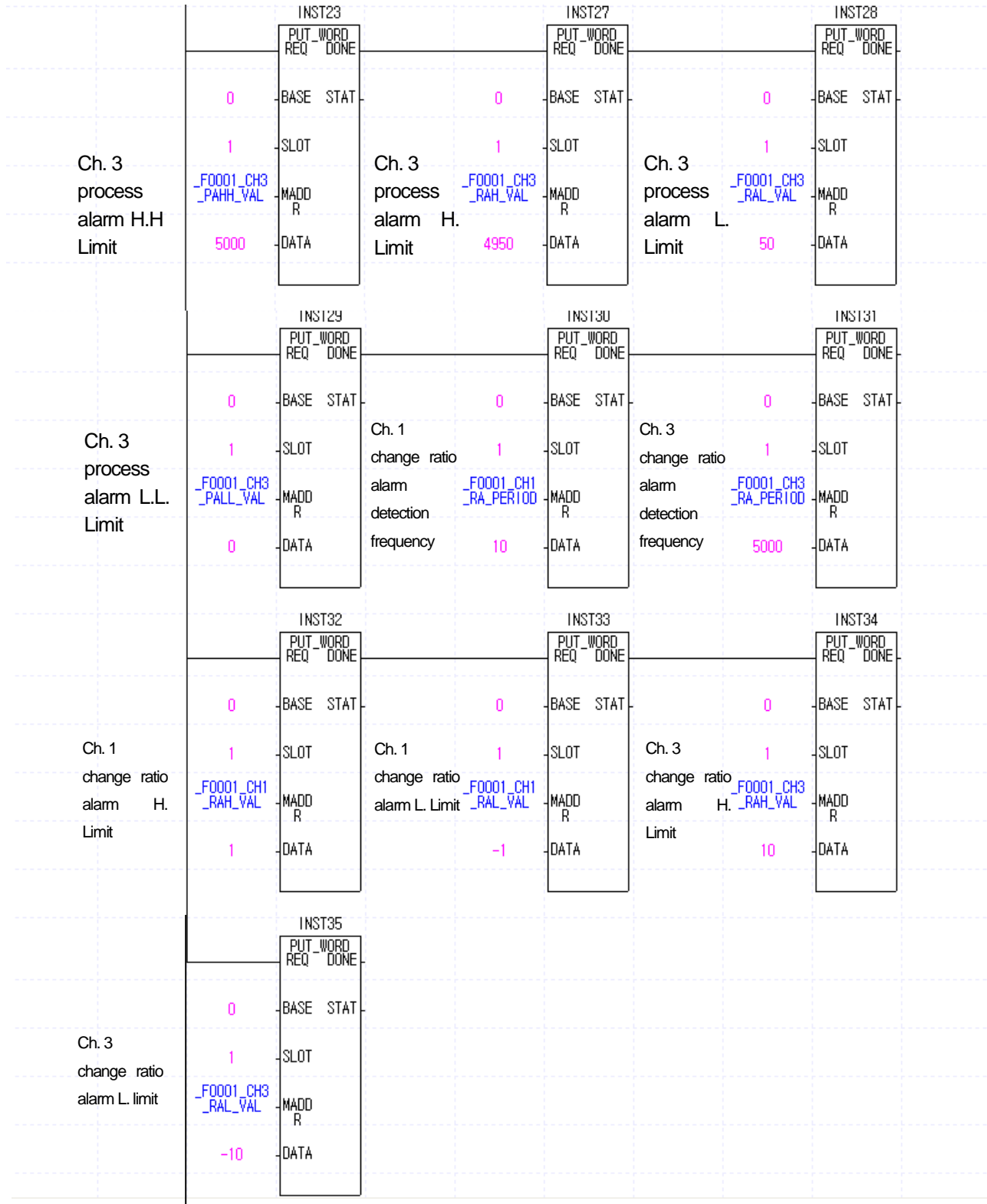

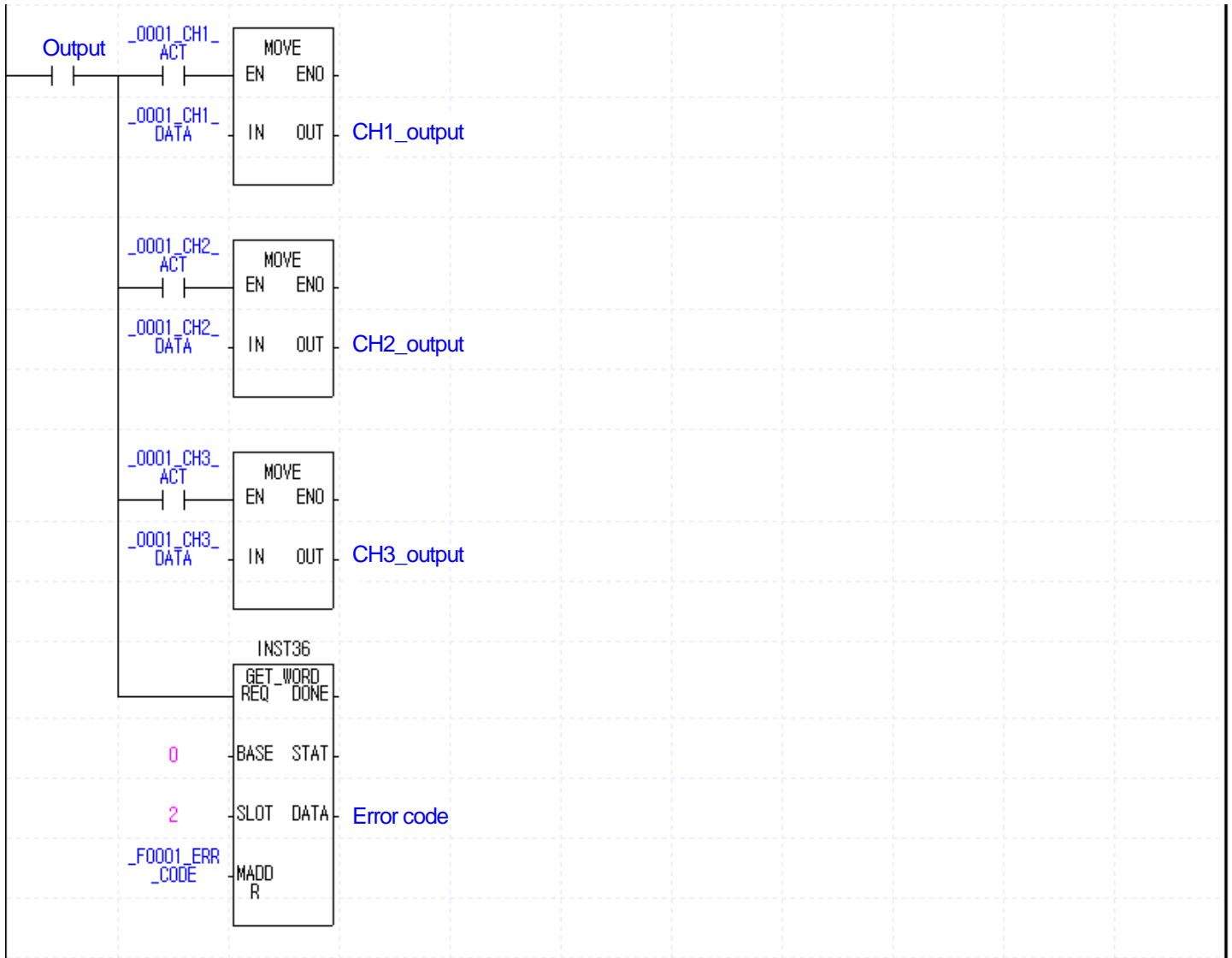

8.2 Applied Program

8.2.1 The Program Distinguishing A/D Conversion Values

(1) System configuration

XGP- ACF2	XGI- CPUU	XGI- D22A	XGF- AW4S	XGQ- RY2A	
--------------	--------------	--------------	--------------	--------------	--

(2) Initial setting

No.	Item	Initial setting	Internal memory address	Values to write in internal memory
1	Channel in use	channel 0, channel 2, channel 3	0	'h000D' or '13'
2	Input voltage range	1 ~ 5V	1	'h1 1 0 1' or '4 3 5 3'
3	Output data range	-32000 ~ 32000	2	'h0000' or '0'
4	Average processing	Channel 0,2,3(weighted, number, time)	3	'h1204' or '4612'
5	Average	Channel 0 weighted average: 50(%)	4	'h0032' or '50'
6	Average	Channel 2 number average: 100(times)	6	'h0064' or '100'
7	Average	Channel 3 time average: 200(ms)	7	'h00C8' or '200'

(3) Program description

- (a) When the digital value of channel 0 is smaller than 12000, contact point 0 (%QX0.2.0) of the relay output module mounted in slot 2 is On.
- (b) When the digital value of channel 2 is greater than 13600, contact point 2 (%QX0.2.2) of the relay output module mounted in slot 2 is On.
- (c) When the digital value of channel 3 is greater than or equal to 12000 and smaller than or equal to 13600, contact point 4 (QX0.2.4) of the relay output module mounted in slot 2 is On.
- (d) When the digital value of channel 3 is 13600, contact point 5 (QX0.2.5) of the relay output module mounted in slot 2 is On.

(4) Program

(a) An example of the program that uses [I/O parameter] setting

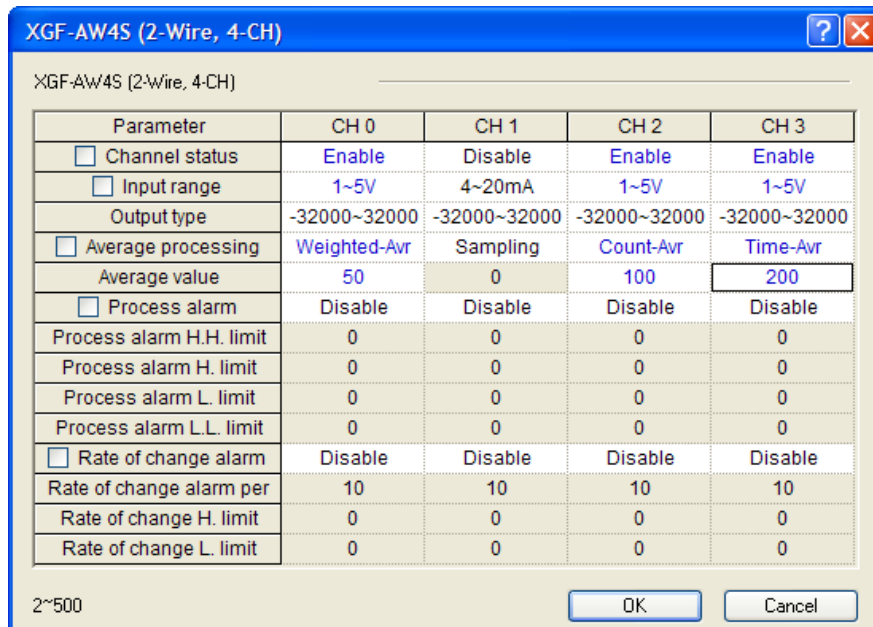
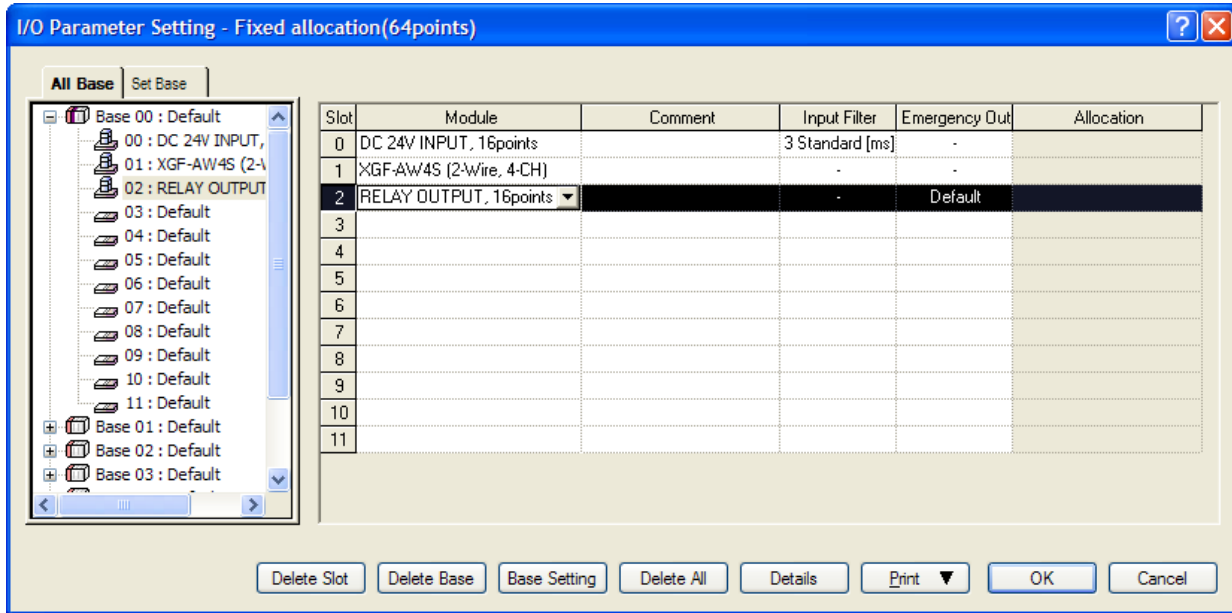

(b) An example of the program that uses [I/O parameter] setting

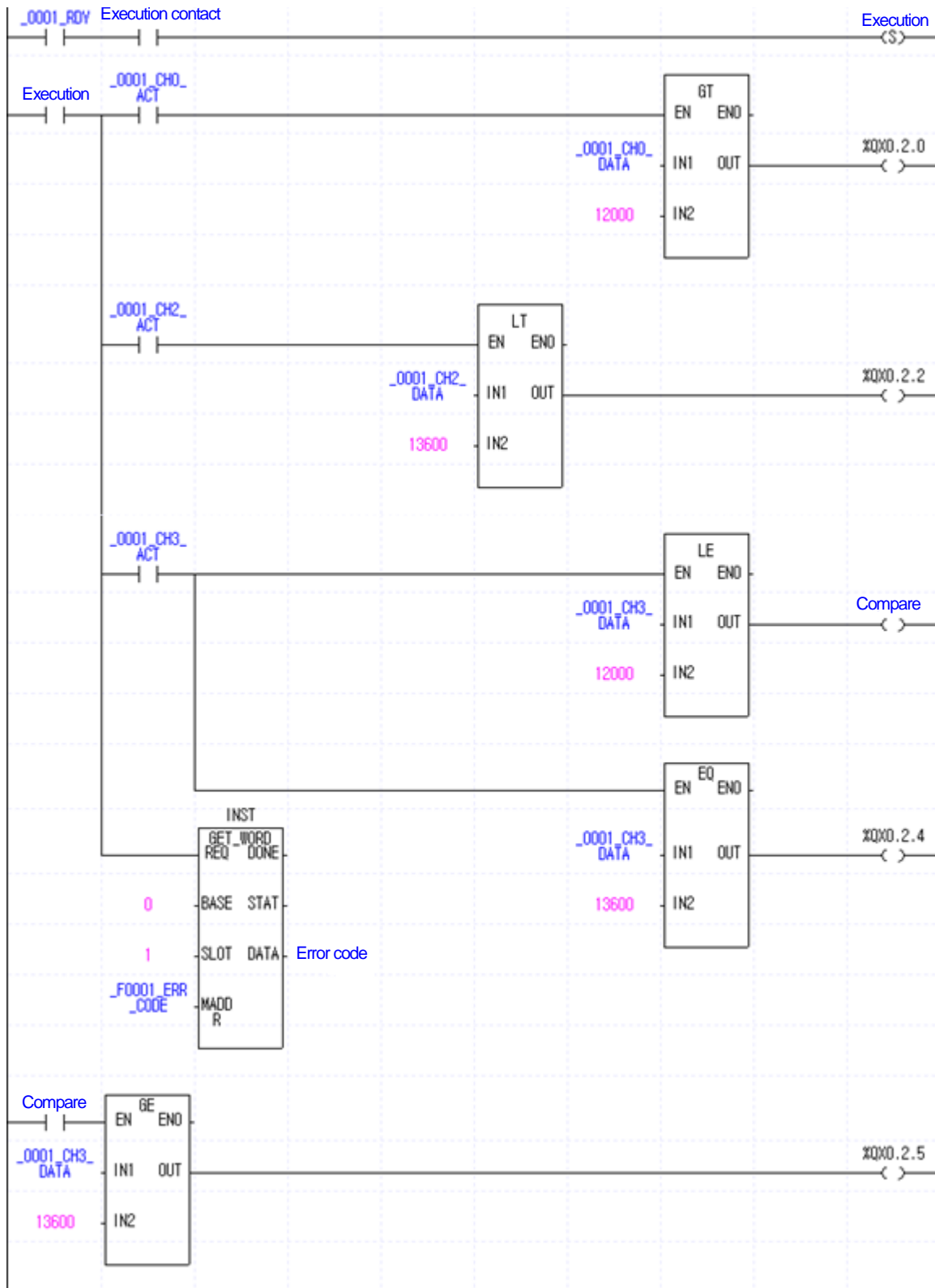

8.2.2 The Program That Outputs the Error Code of the Analog Input Module through BCD Display

(1) System configuration

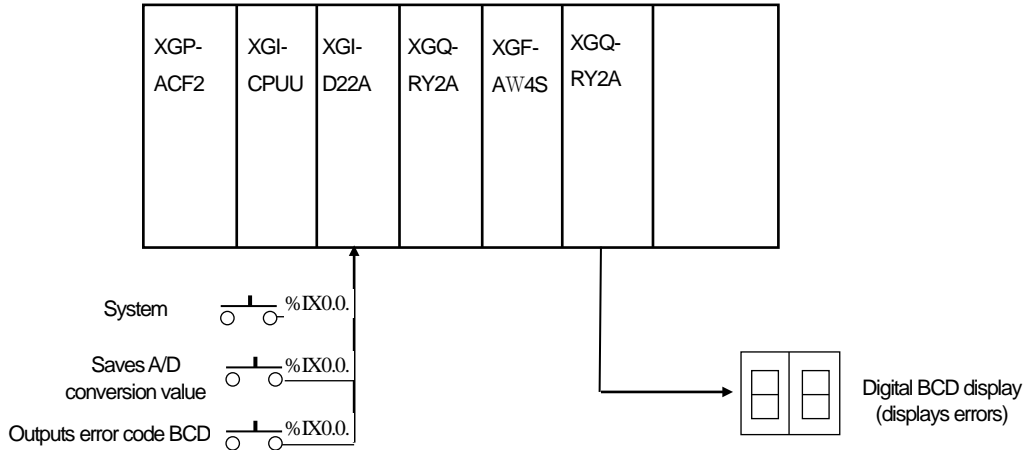

(2) Initial setting

- (a) Channel in use: channel 0
- (b) Analog input current range: DC 4 ~ 20 mA
- (c) Time average processing: 100 (ms)
- (d) Digital output data range: -32000~32000

(3) Program description

- (a) When %IX.0.0.1 is On, the A/D conversion value and error code are respectively saved as conversion value and error code.
- (b) When %IX.0.0.2 is On, the error code is output in the digital BCD display (%QW.0.3.0).

(4) Program

- (a) An example of the program that uses [I/O parameter] setting

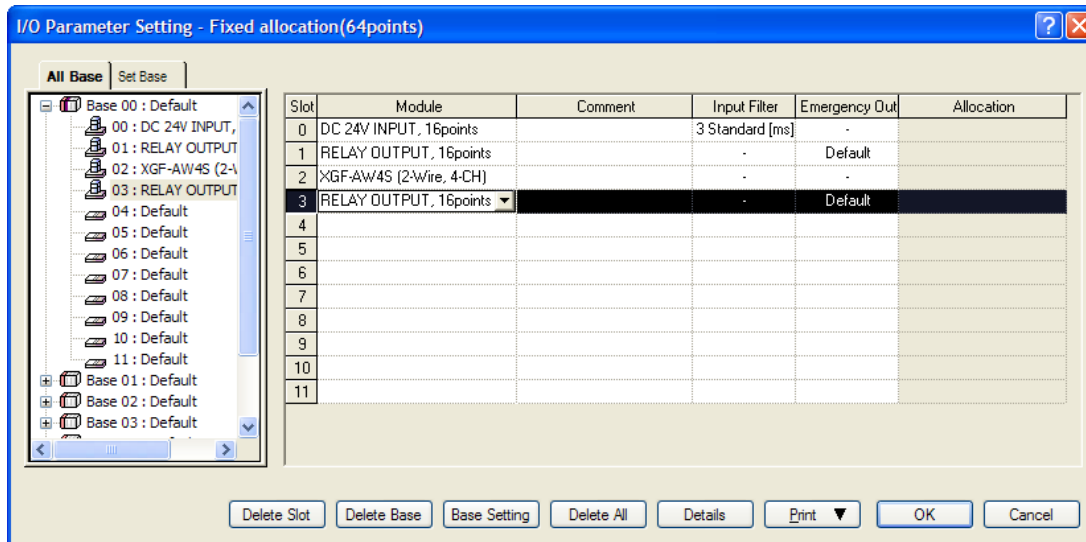

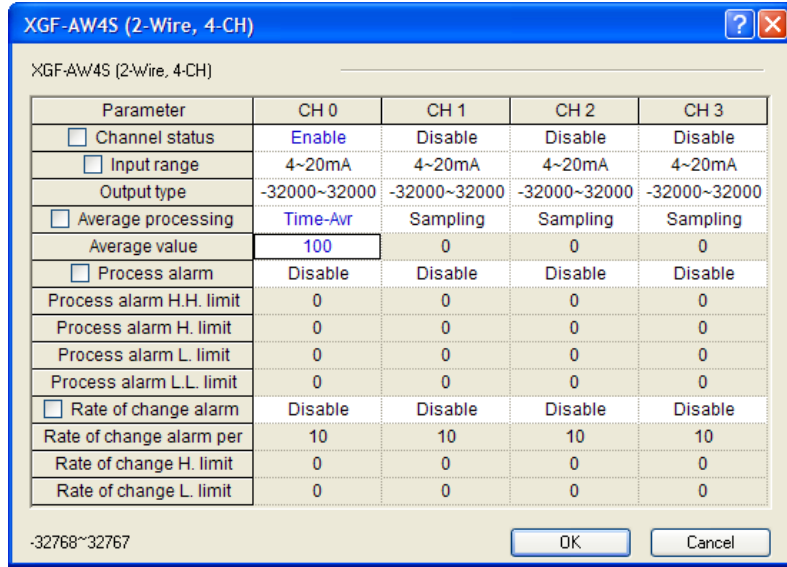

(b) An example of the program that uses [I/O parameter] setting

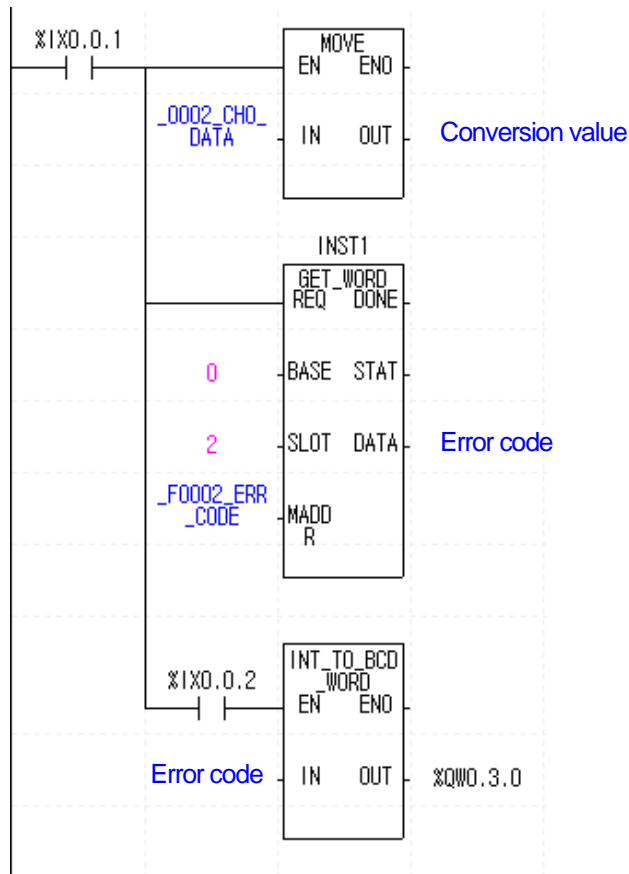

Chapter 9 Failure Check

This chapter provides information on the errors and failure check of the 2-wire analog input module.

9.1 Error Code

Table 9.1 shows the errors that occur when the RUN LED of the 2-wire analog input module flashes.

[Table 9. 1] Error code list

Error code (Decimal)	Description of the error	RUN LED
0	Normal operation	RUN LED on
10	module error (ASIC Reset Error)	RUN LED flashes every 0.2 second
11	module error (ASIC RAM or Register Error)	
20#	Beyond the time average setting range	RUN LED flashes every second
30#	Beyond the number average setting range	
40#	Beyond the moving average setting range	
50#	Beyond the weighted average setting range	
60#	Beyond the change rate detection cycle setting range	

Notes

- (1) # of the error code means the channel where the error occurred.
- (2) If there are two or more errors, the module saves the error code that happened first and does not save the following error codes.
- (3) If you use an error clear request flag, you can delete the error code in the sequence program (see 5.2.5).

9.2 Failure Check

9.2.1 RUN LED Flashes

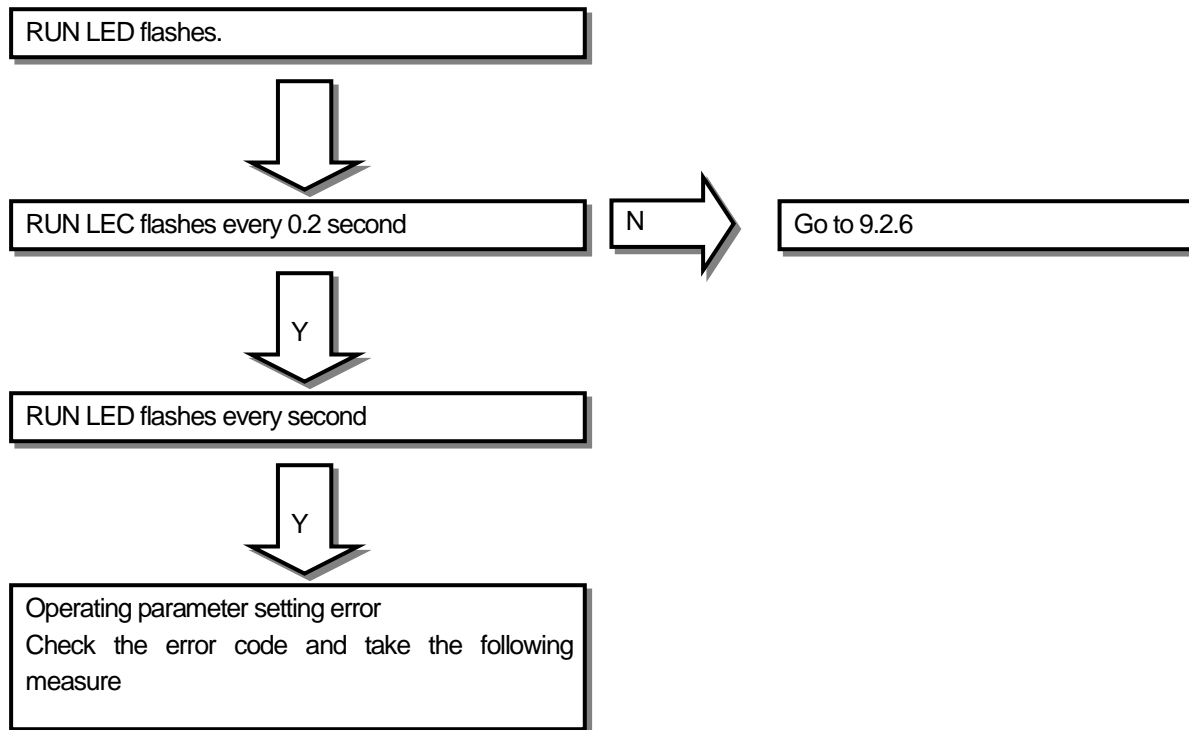

Error code (Decimal)	Description of the error	Action
20#	Beyond the time average setting range	Change the set value to 20 ~ 5000.
30#	Beyond the number average setting range	Change the set value to 2 ~ 500.
40#	Beyond the moving average setting range	Change the set value to 2 ~ 100.
50#	Beyond the weighted average setting range	Change the set value to 1 ~ 99.
60#	Beyond the change rate detection cycle setting range	Change the set value to 10 ~ 5000.

9.2.2 RUN LED Is Off

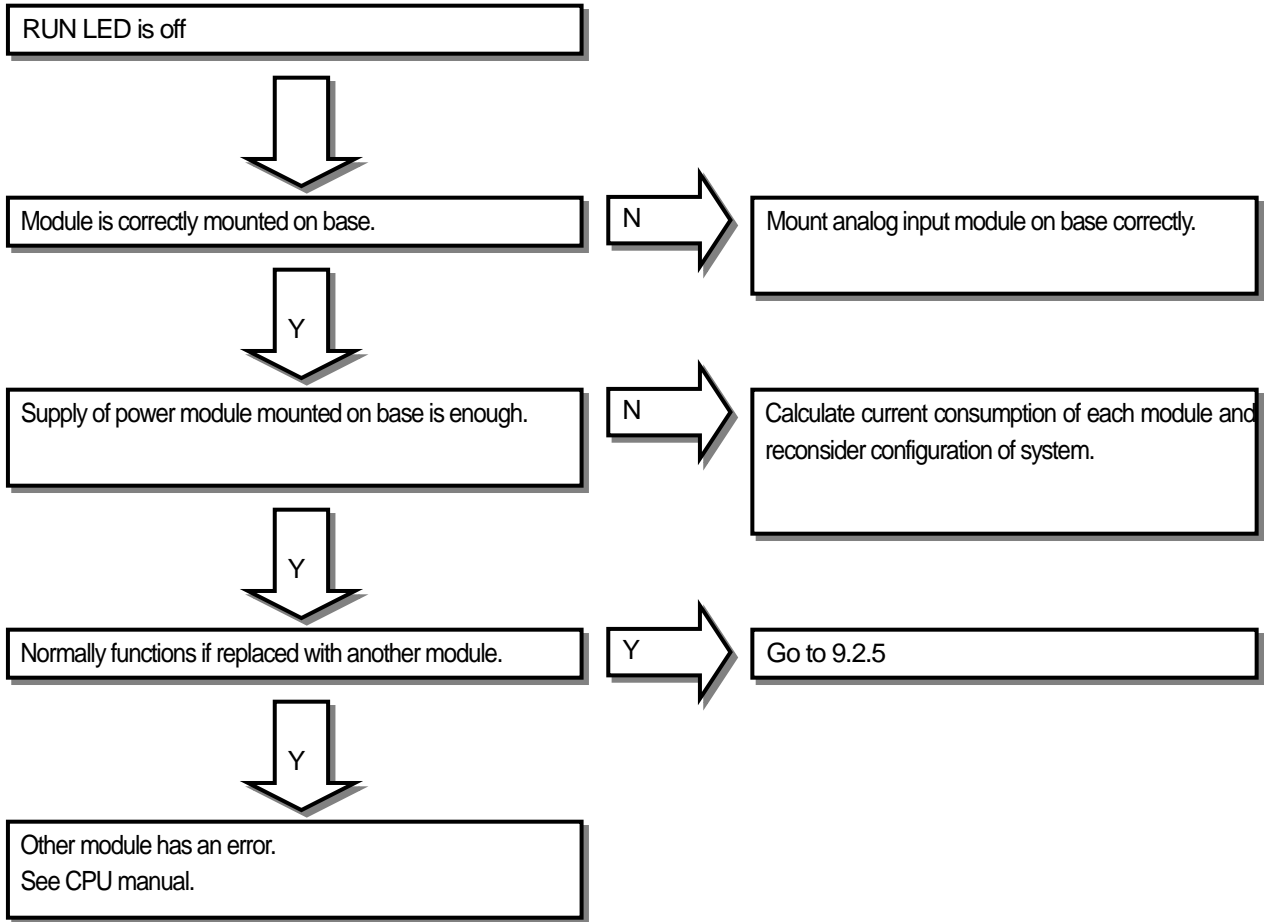

9.2.3 CPU Module Cannot Read A/D Conversion Values

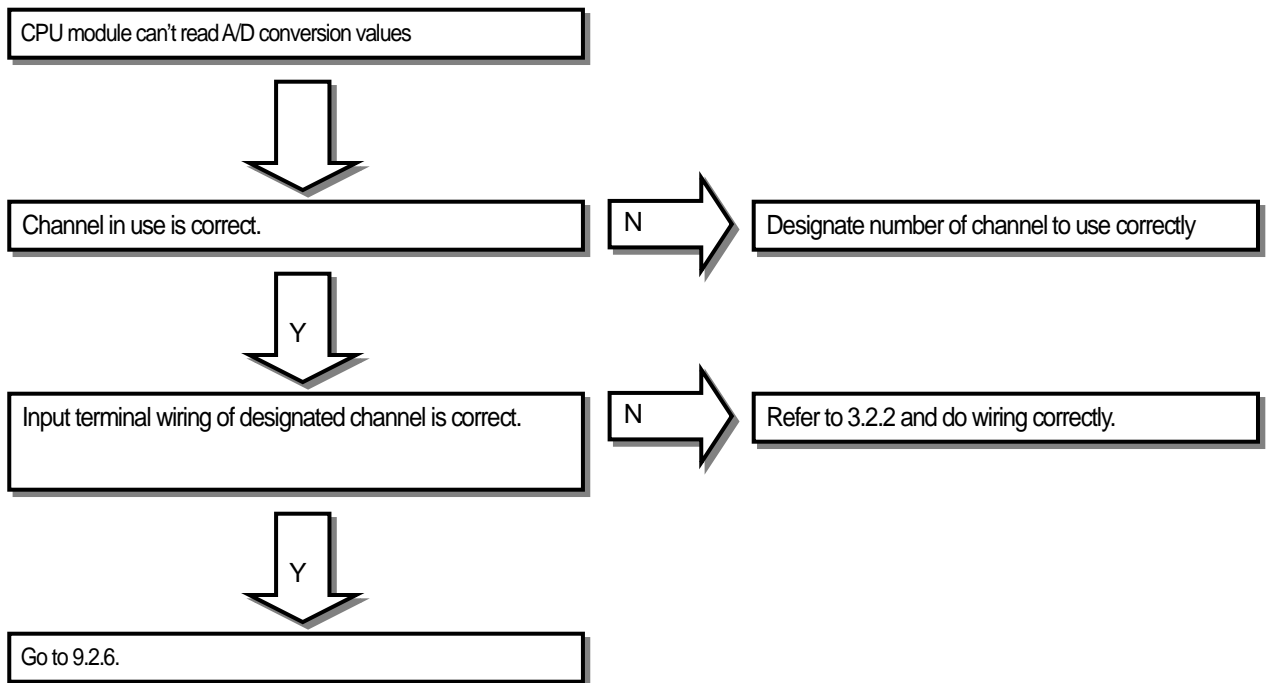

9.2.4 The Analog Input Value Inconsistent with Digital Output Value

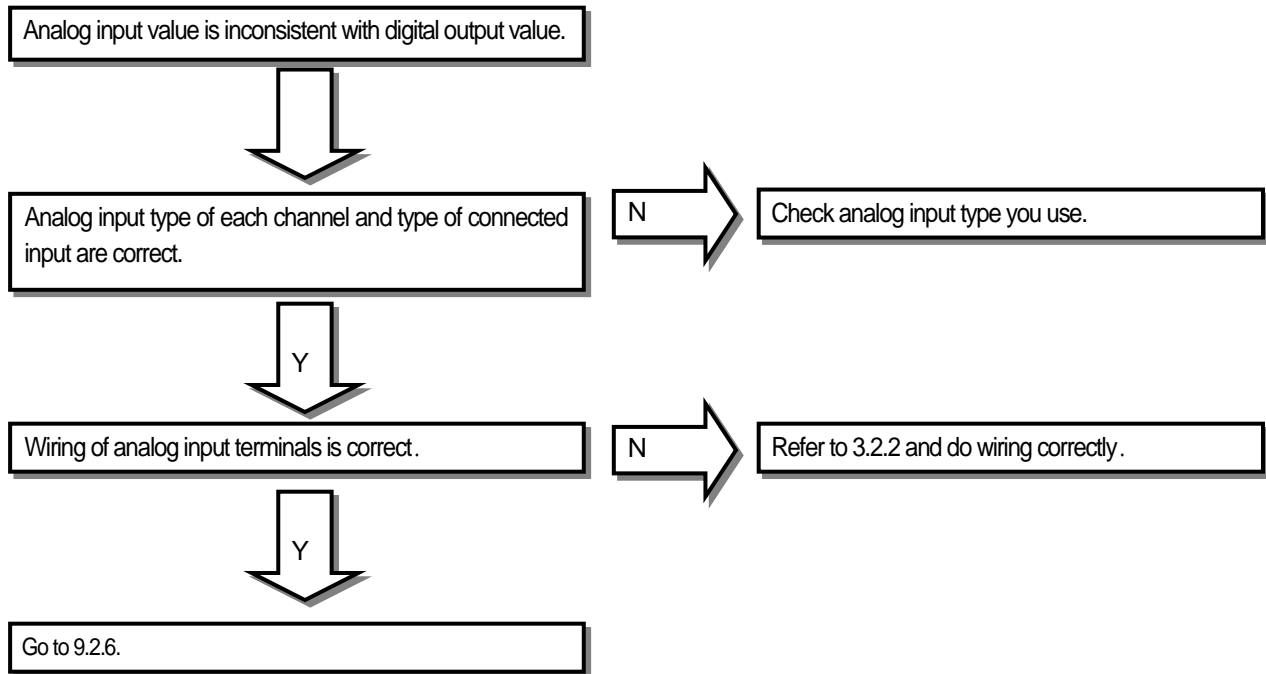

9.2.5 Values Cannot Be Monitored during Transmitter Wiring Work

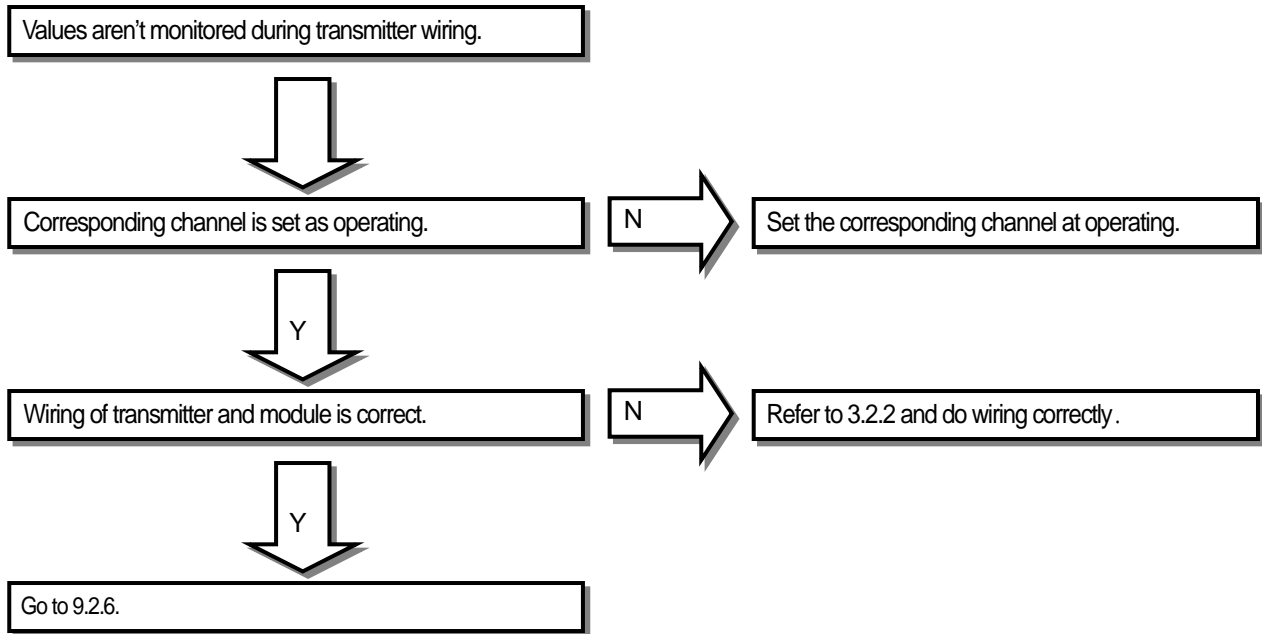

9.2.6 Hardware Failure of the 2-Wire Analog Input Module

Switch on/off the power. If it occurs again, a module failure is suspected. Contact us.

9.2.7 Check of Analog Input Module Status by XG5000 System Monitor

You can check the module type, information, OS version and status of the analog input module by system monitor of XG5000.

(1) Sequence

You can do the job either ways.

- (a) [Monitor] -> [System monitor] -> press right button of mouse on module figure -> [module information]
- (b) [Monitor] -> [System monitor] -> double-click on module figure

(2) Module information

- (a) Module type: displays the information of the currently mounted module.
- (b) Module information: displays the OS version information of the analog input module.
- (c) OS version: displays the data when the analog input module OS was configured.
- (d) Module status: displays the current error code (for details, see Table 9.1).

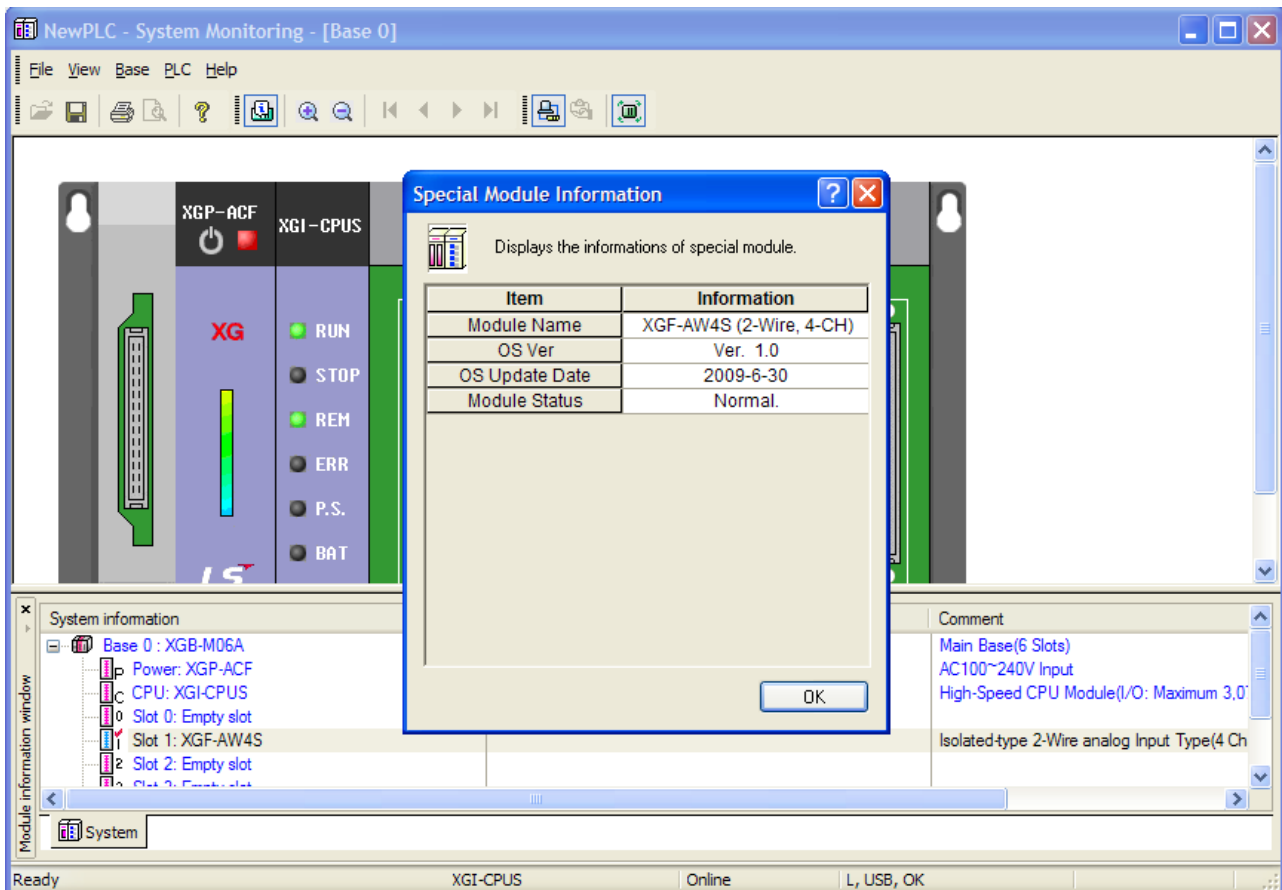

Appendix 1 Glossary

The following glossary covers the manual and the entire analog module.

- **A/D converter:** converts the analog input signals into digital values in proportion to the magnitude of the signals.
- **Analog input module:** The module that has a circuit which converts analog voltage/current input signals into digital values. It has 14 or 16 bit resolutions according to the converter.
- **Channel:** Related to the terminals of the analog input/output module, each channel is linked to various current/voltage input and output devices and has the functions of data and check.
- **Conversion time:** The time it takes for the analog input module samples and converts the analog signals and then for the processor in the module to receive the converted digital values. In addition, this is the time for the digital values from the processor in the module to be converted into analog output signals and transmitted to the output channel.
- **D/A converter:** Performs the function of producing analog voltage and current signals of continuous size in proportion to the digital value.
- **Full scale:** The magnitude of voltage and current at which normal function is performed.
- **Full scale error:** The difference between an ideal analog conversion value and real analog conversion value on the graph.
- **Full scale range:** The difference between the maximum and minimum of the analog inputs.
- **LSB (Least Significant Bit):** The minimum of the unit bit line.
- **Transmitter:** The circuit that receives signals or data and converts them into the form transmittable through media.

- **Linearity error:** The analog inputs and outputs being related to continuous voltage/current and digital values, ideal inputs and outputs are defines as a straight line within minimum 1LSB of voltage/current. The difference between an ideal analog conversion value and real analog conversion value on the graph is referred to as a linearity error.

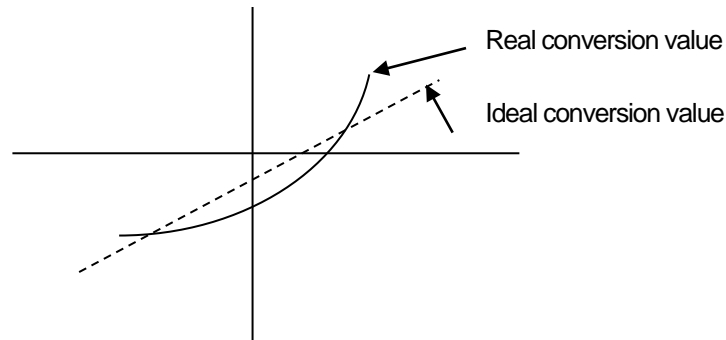

- **Multiplexer:** The switching circuit where multiple circuits share a single A/D converter or D/A converter.
- **Analog output module:** The module that has an output module which converts the analog DC voltage or current signals in proportion to the digital values transmitted from the processor to the module.
- **Resolution:** The minimum value that can be recognized in the measure. It is expressed in engineering units (1mV or number of Bits) in general. That is, 14 Bit is capable of 16383 types of outputs.
- **Filter:** The device that softens the change of digital conversion values of an analog circuit produced from a sudden change of external noise or inputs. It has two methods of SW and HW filters.
- **Precision:** The maximum deviation of the ideal output voltage and current against the pre-output range. With respect to the outputs, it is expressed as the maximum difference between the ideal value in the whole input range and the digital conversion value of the input signals. It is mainly expressed in percentage to the full scale. The error includes the gain, offset and linearity errors.
- **Output precision:** The difference between an real analog output voltage/current value and ideal conversion value on the graph. It is expressed against the full scale, and the error includes the gain, offset and linearity errors. It is expressed respectively in room temperature (25°C) and use temperature ranges.

Appendix 2 Dimension

Appendix2.1 Dimension of XGF-AW4S

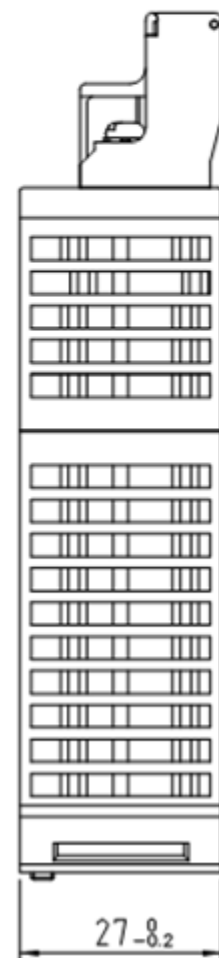
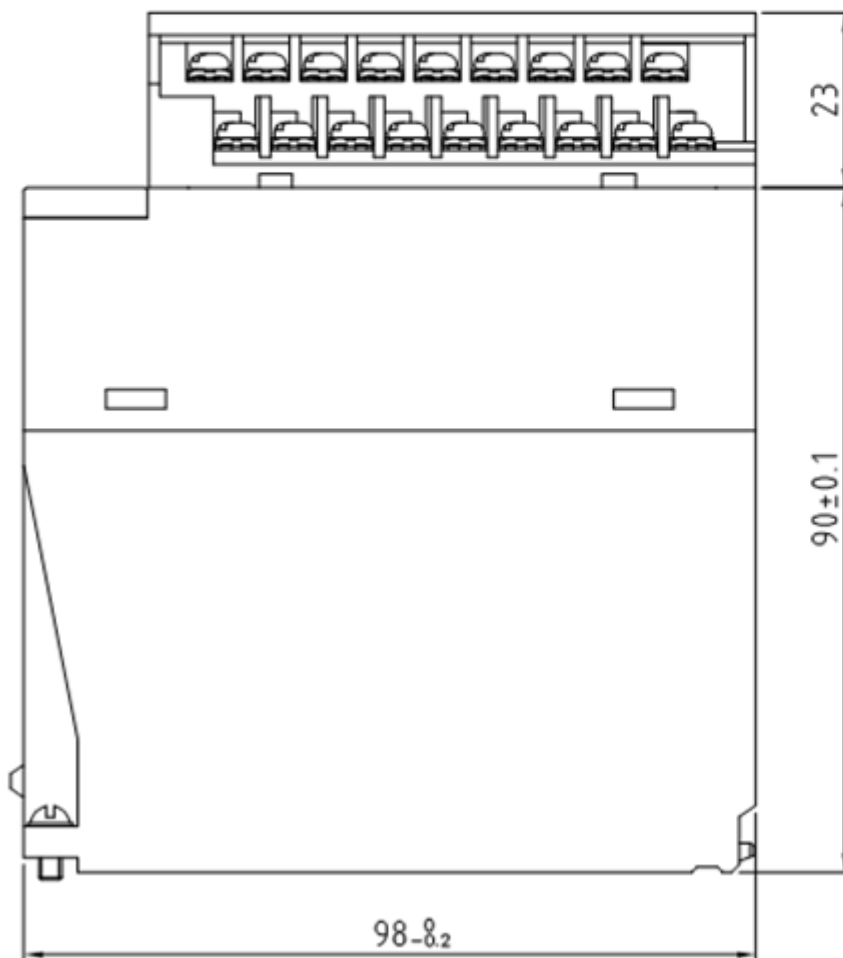
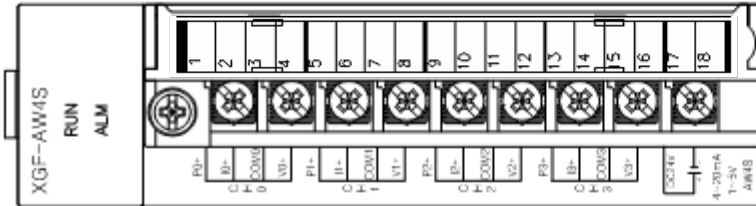

Warranty

1. Warranty Period

The product you purchased will be guaranteed for 18 months from the date of manufacturing.

2. Scope of Warranty

Any trouble or defect occurring for the above-mentioned period will be partially replaced or repaired. However, please note the following cases will be excluded from the scope of warranty.

- (1) Any trouble attributable to unreasonable condition, environment or handling otherwise specified in the manual,
- (2) Any trouble attributable to others' products,
- (3) If the product is modified or repaired in any other place not designated by the company,
- (4) Due to unintended purposes
- (5) Owing to the reasons unexpected at the level of the contemporary science and technology when delivered.
- (6) Not attributable to the company; for instance, natural disasters or fire

3. Since the above warranty is limited to PLC unit only, make sure to use the product considering the safety for system configuration or applications.

Environmental Policy

LS ELECTRIC Co., Ltd supports and observes the environmental policy as below.

Environmental Management

LS ELECTRIC considers the environmental preservation as the preferential management subject and every staff of LS ELECTRIC use the reasonable endeavors for the pleasurable environmental preservation of the earth.

About Disposal

LS ELECTRIC' PLC unit is designed to protect the environment. For the disposal, separate aluminum, iron and synthetic resin (cover) from the product as they are reusable.



www.ls-electric.com

LS ELECTRIC Co., Ltd.

■ Headquarter

LS-ro 127(Hogye-dong) Dongan-gu, Anyang-si, Gyeonggi-Do, 14119, Korea

■ Seoul Office

LS Yongsan Tower, 92, Hangang-daero, Yongsan-gu, Seoul, 04386, Korea

Tel: 82-2-2034-4033, 4888, 4703 Fax: 82-2-2034-4588

E-mail: automation@ls-electric.com

■ Overseas Subsidiaries

• LS ELECTRIC Japan Co., Ltd. (Tokyo, Japan)

Tel: 81-3-6268-8241 E-Mail: japan@ls-electric.com

• LS ELECTRIC (Dalian) Co., Ltd. (Dalian, China)

Tel: 86-411-8730-6495 E-Mail: china.dalian@lselectric.com.cn

• LS ELECTRIC (Wuxi) Co., Ltd. (Wuxi, China)

Tel: 86-510-6851-6666 E-Mail: china.wuxi@lselectric.com.cn

• LS ELECTRIC Middle East FZE (Dubai, U.A.E.)

Tel: 971-4-886-5360 E-Mail: middleeast@ls-electric.com

• LS ELECTRIC Europe B.V. (Hoofddorp, Netherlands)

Tel: 31-20-654-1424 E-Mail: europartner@ls-electric.com

• LS ELECTRIC America Inc. (Chicago, USA)

Tel: 1-800-891-2941 E-Mail: sales.us@lselectricamerica.com

• LS ELECTRIC Turkey Co., Ltd.

Tel: 90-212-806-1225 E-Mail: turkey@ls-electric.com

■ Overseas Branches

• LS ELECTRIC Tokyo Office (Japan)

Tel: 81-3-6268-8241 E-Mail: tokyo@ls-electric.com

• LS ELECTRIC Beijing Office (China)

Tel: 86-10-5095-1631 E-Mail: china.auto@lselectric.com.cn

• LS ELECTRIC Shanghai Office (China)

Tel: 86-21-5237-9977 E-Mail: china.auto@lselectric.com.cn

• LS ELECTRIC Guangzhou Office (China)

Tel: 86-20-3818-2883 E-Mail: china.auto@lselectric.com.cn

• LS ELECTRIC Chengdu Office (China)

Tel: 86-28-8670-3201 E-Mail: china.auto@lselectric.com.cn

• LS ELECTRIC Qingdao Office (China)

Tel: 86-532-8501-2065 E-Mail: china.auto@lselectric.com.cn

• LS ELECTRIC Nanjing Office (China)

Tel: 86-25-8467-0005 E-Mail: china.auto@lselectric.com.cn

• LS ELECTRIC Bangkok Office (Thailand)

Tel: 66-90-950-9683 E-Mail: thailand@ls-electric.com

• LS ELECTRIC Jakarta Office (Indonesia)

Tel: 62-21-2933-7614 E-Mail: indonesia@ls-electric.com

• LS ELECTRIC Moscow Office (Russia)

Tel: 7-499-682-6130 E-Mail: info@lselectric-ru.com

• LS ELECTRIC America Western Office (Irvine, USA)

Tel: 1-949-333-3140 E-Mail: america@ls-electric.com

Disclaimer of Liability

LS ELECTRIC has reviewed the information in this publication to ensure consistency with the hardware and software described. However, LS ELECTRIC cannot guarantee full consistency, nor be responsible for any damages or compensation, since variance cannot be precluded entirely. Please check again the version of this publication before you use the product.

© LS ELECTRIC Co., Ltd 2010 All Right Reserved.

2022.08