

The right choice for the ultimate yield!

LS ELECTRIC strives to maximize your profits in gratitude for choosing us as your partner.

# AC Variable Speed Drive

LSLV-SP100 series

User's Manual

5.5-18.5kW [200V] 5.5-55kW [400V]

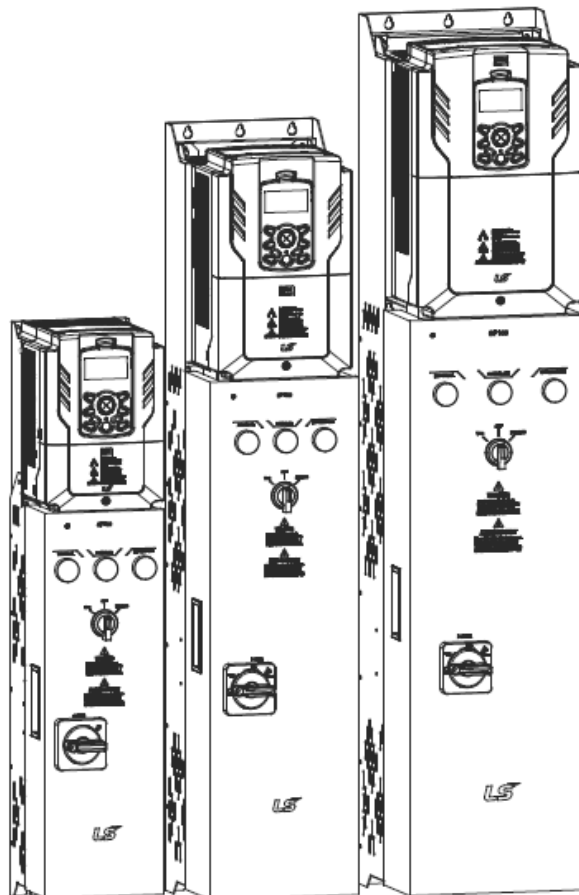

## Safety Instructions

- Read this manual carefully before installing, wiring, operating, servicing or inspecting this equipment.
- Keep this manual within easy reach for quick reference.

**LS**ELECTRIC

---

# Safety Information

Read and follow all safety instructions in this manual precisely to avoid unsafe operating conditions, property damage, personal injury, or death.

## Safety symbols in this manual

### Danger

Indicates an imminently hazardous situation which, if not avoided, will result in severe injury or death.

### Warning

Indicates a potentially hazardous situation which, if not avoided, could result in injury or death.

### Caution

Indicates a potentially hazardous situation that, if not avoided, could result in minor injury or property damage.

## Safety information

### Danger

- Do not open the cover of the equipment while it is on or operating. Likewise, do not operate the inverter while the cover is open. Exposure of high voltage terminals or charging area to the external environment may result in an electric shock. Do not remove any covers or touch the internal circuit boards (PCBs) or electrical contacts on the product when the power is on or during operation. Doing so may result in serious injury, death, or serious property damage.
- Do not open the cover of the equipment even when the power supply to the inverter has been turned off unless it is necessary for maintenance or regular inspection. Opening the cover may result in an electric shock even when the power supply is off.
- The equipment may hold charge long after the power supply has been turned off. Use a multi-meter to make sure that there is no voltage before working on the inverter, motor or motor cable.
- Supply earthing system: TT, TN, not suitable for corner-earthed systems

### Warning

- This equipment must be grounded for safe and proper operation.
- Do not supply power to a faulty inverter. If you find that the inverter is faulty, disconnect the power supply and have the inverter professionally repaired.
- The inverter becomes hot during operation. Avoid touching the inverter until it has cooled to avoid burns.
- Do not allow foreign objects, such as screws, metal chips, debris, water, or oil to get inside the inverter. Allowing foreign objects inside the inverter may cause the inverter to malfunction or result in a fire.
- Do not operate the inverter with wet hands. Doing so may result in electric shock.

### Caution

- Do not modify the interior workings of the inverter. Doing so will void the warranty.
- The inverter is designed for 3-phase motor operation. Do not use the inverter to operate a single phase motor.
- Do not place heavy objects on top of electric cables. Doing so may damage the cable and result in an electric shock.

# Table of Contents

<b>1 Introduction</b> .....	<b>4</b>
1.1 Purpose of the Manual .....	4
1.2 Product Identification .....	4
1.3 Part Names .....	6
1.4 Block Diagram.....	10
<b>2 Installation Instruction</b> .....	<b>11</b>
2.1 Installation Considerations .....	11
2.2 Product Weight .....	11
2.3 External Dimensions.....	13
2.4 Cable Selection.....	16
2.5 Peripheral Devices.....	19
2.6 Terminal Screw Specifications .....	20
2.7 Cable Wiring.....	21
2.8 Configuration and Wiring of Input/Output Control Terminal.....	24
2.9 Configuration and Descriptions of Indicators and Switches .....	27
<b>3 Start-Up Procedure</b> .....	<b>36</b>
3.1 Test Run .....	36
3.2 Parameter Settings .....	40
3.2.1 Table of Functions.....	40
3.2.2 Functions of SP100 .....	41
3.3 Examples of Set-Up for Advanced Operation .....	42
3.3.1 Basic Bypass Operation .....	42
3.3.2 Advanced Bypass Operation .....	44
<b>4 Fault Trips</b> .....	<b>46</b>
4.1 Trip Items during the Bypass Operation .....	46
4.2 Trip Items That Can Automatically Switch to the Bypass Operation during the Inverter Operation.....	47
<b>5 Technical Specification</b> .....	<b>48</b>
<b>6 Product Warranty</b> .....	<b>51</b>

# 1 Introduction

## 1.1 Purpose of the Manual

This instruction manual provides information for safe installation, and commissioning of the SP100 Series.

Read and follow the instruction manual in order to use the SP100 Series safely and professionally, and pay particular attention to the safety instructions and general warnings. Keep this instruction manual available with the SP100 Series at all times.

### Note

Detailed informations for each parameter is on technical manual.

## 1.2 Product Identification

Product name and specifications are detailed on the rating plate. Check the rating plate before installing the product and make sure that the product meets your requirements. For more detailed product specifications.

### Note

Check the product name, open the packaging, and then confirm that the product is free from defects. Contact your supplier if you have any issues or questions about your product.

Model Name

**LSLV0055SP100-2CEND3**

Power source specifications

INPUT 200-240 V 3 Phase 60 Hz

ND : 23.7A

Output Specifications

OUTPUT 0-Input V 3 Phase 0.01-400Hz

ND : 22A

Field Wiring Diagram : See Manual Page No, 15, 19, 44-46

Filed Provided Component : See Manual Page No, 17

SCCR : 5kA , Environmental Type : Type 1

Ser. No 12030100001 Inspected by K. D. Hong



**LSLV 0055 SP100 - 4 C E F D 3**

Motor capacity

0055 – 5.5kW	0220 – 22kW
0075 – 7.5kW	0300 – 30kW
0110 – 11kW	0370 – 37kW
0150 – 15kW	0450 – 45kW
0185 – 18.5kW	0550 – 55kW

Series name

Input voltage

2 – 3-Phase 200V  
4 – 3-Phase 400V

Keypad TYPE

C - LCD Keypad

UL TYPE

E - UL Type 1

EMC TYPE

F - Built-in EMC  
N - None-EMC

Reactor TYPE

A - Built-in AC Reactor  
D - Built-in DC Reactor

Contactor TYPE

3 – Three Contactor

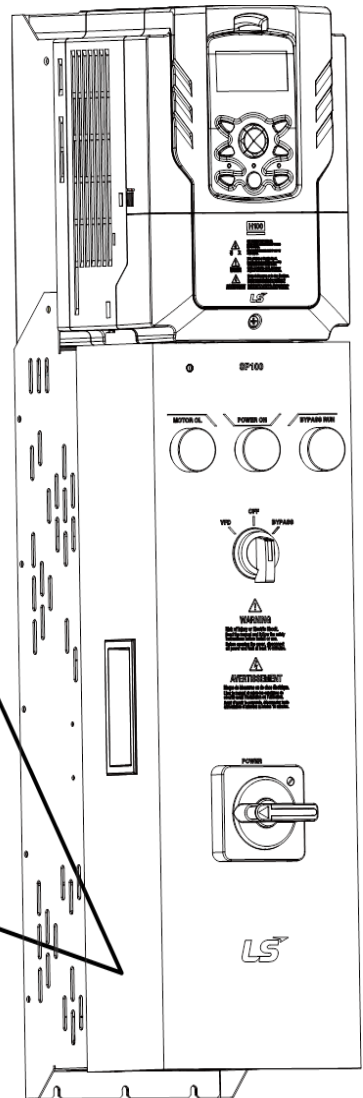

## 1.3 Part Names

The illustration below displays part names. Details may vary between product groups.

### 5.5–18.5 kW-200V Type

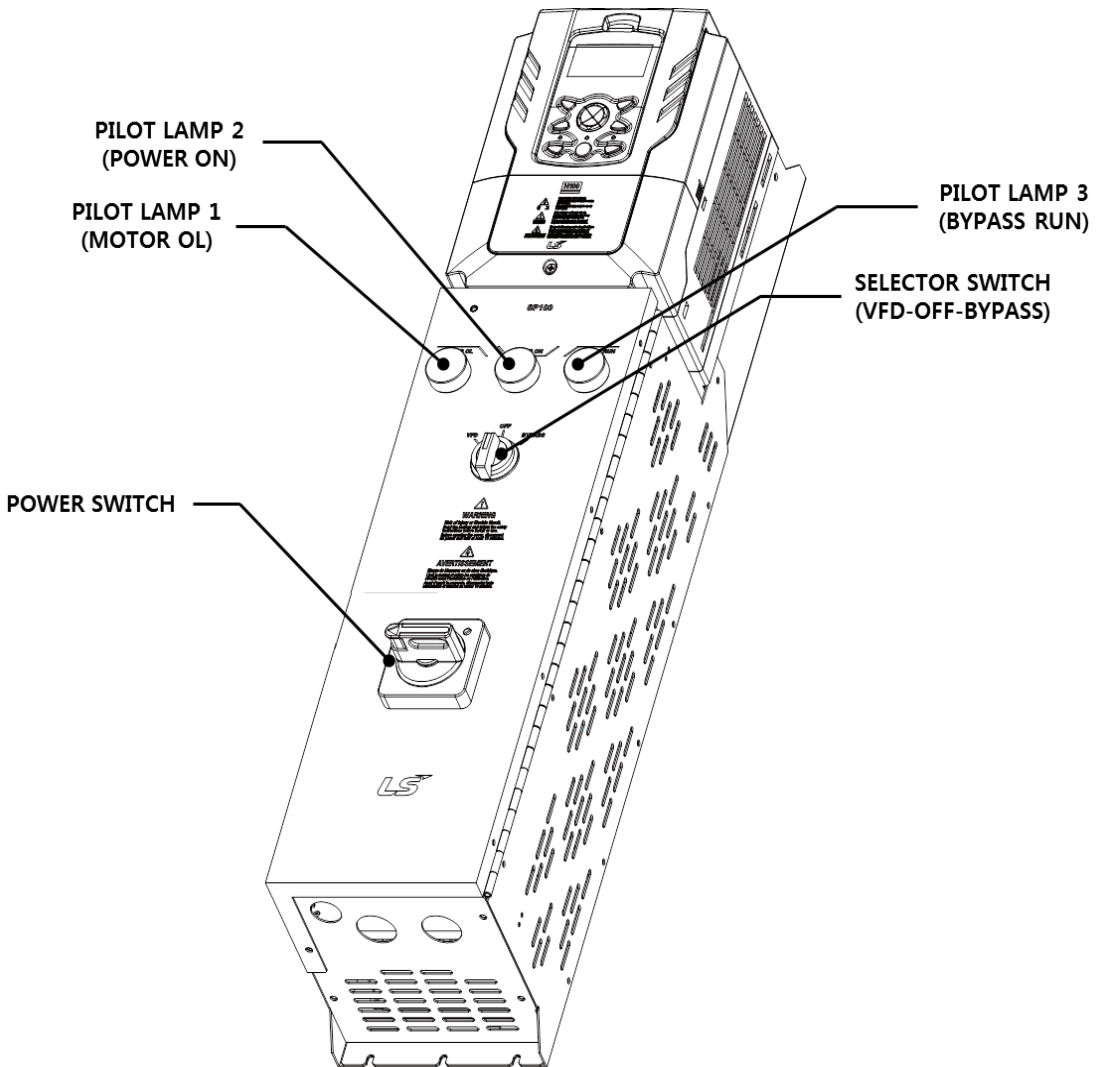

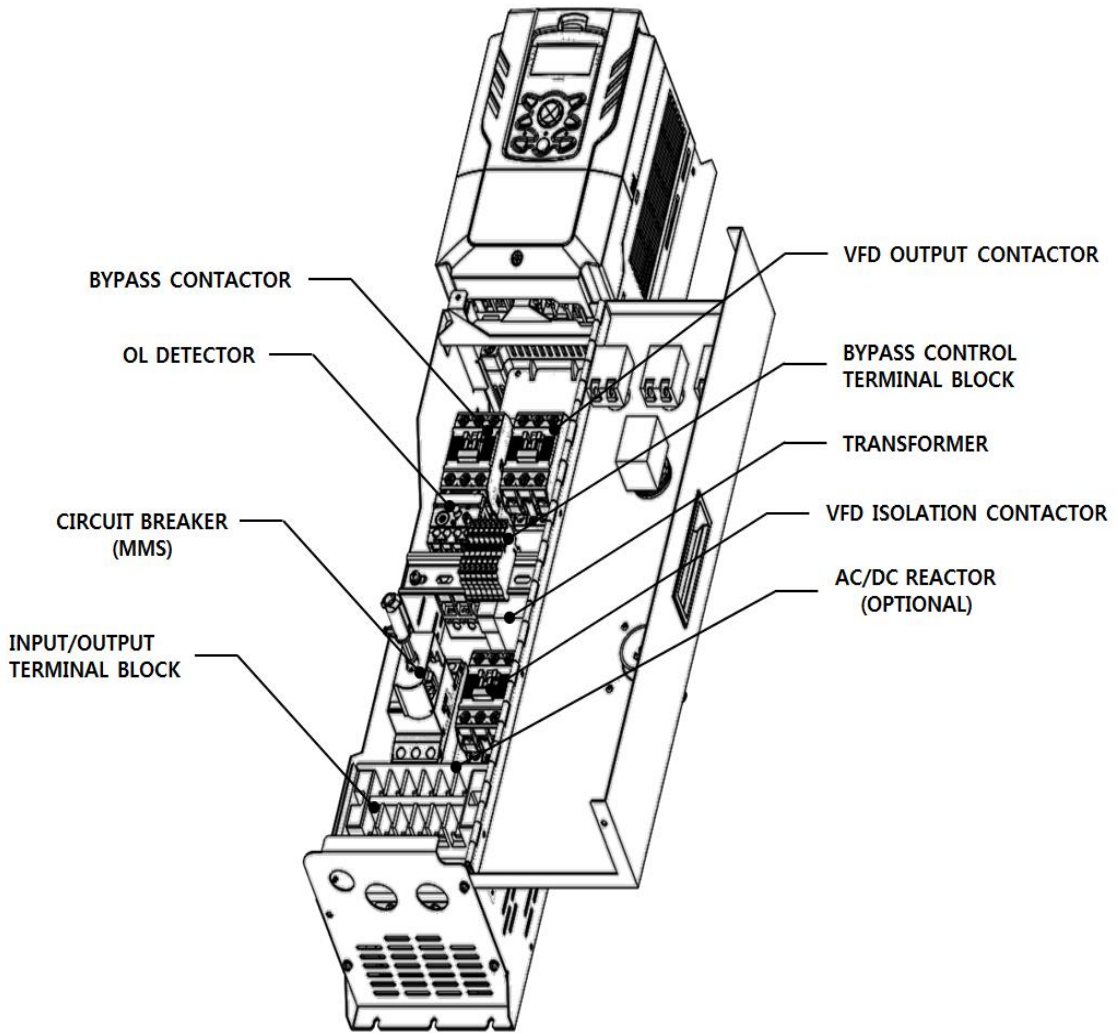

## 5.5–55 kW-400V Type

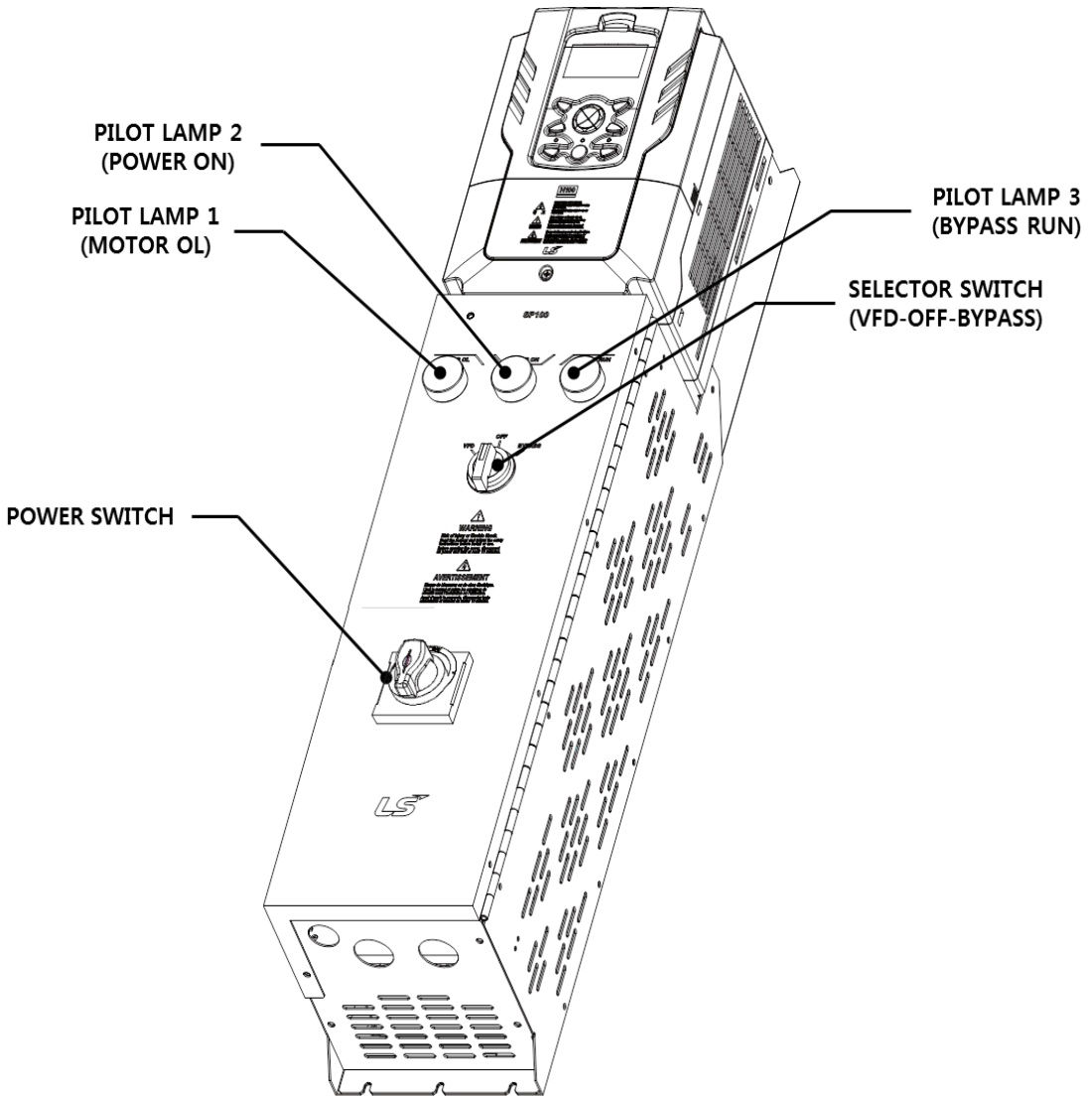

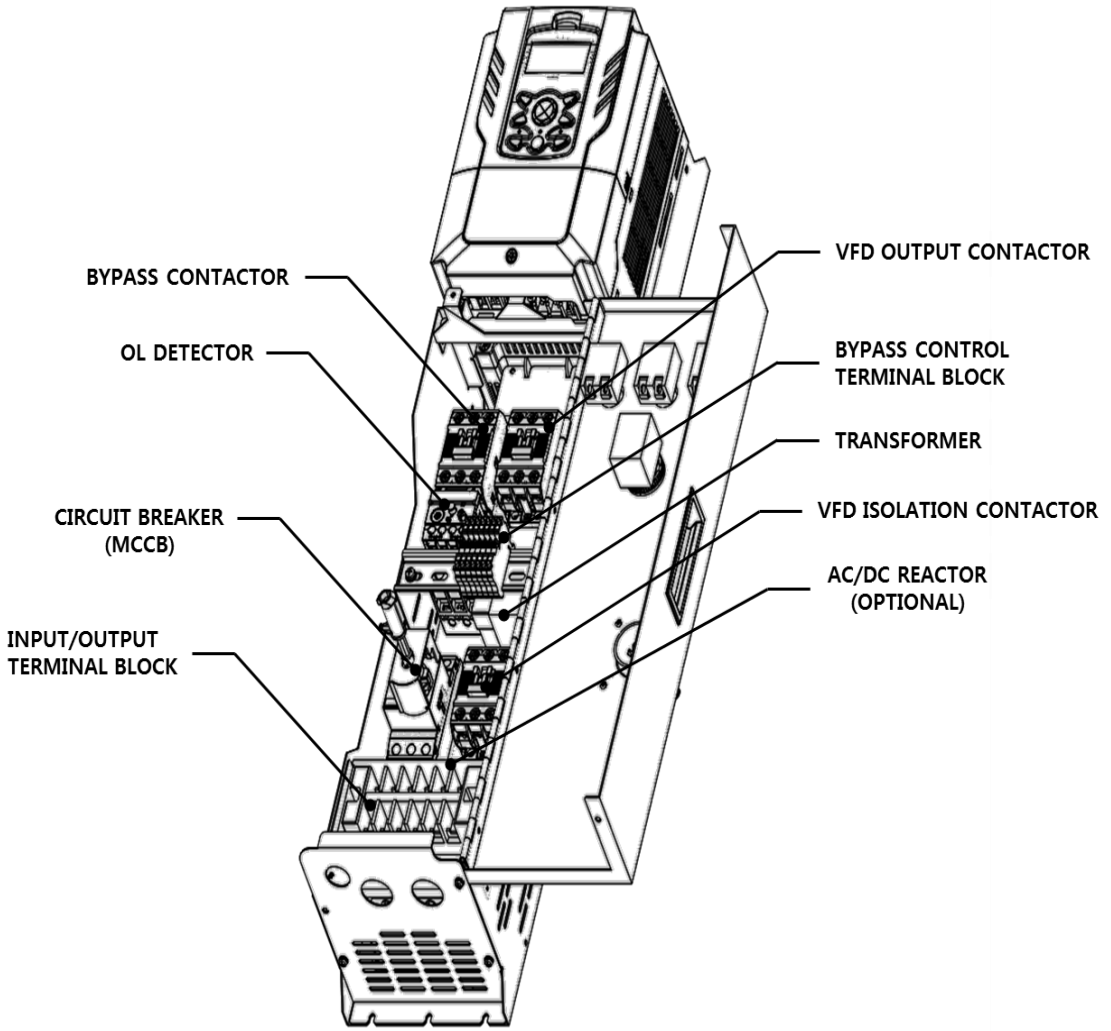

## 1.4 Block Diagram

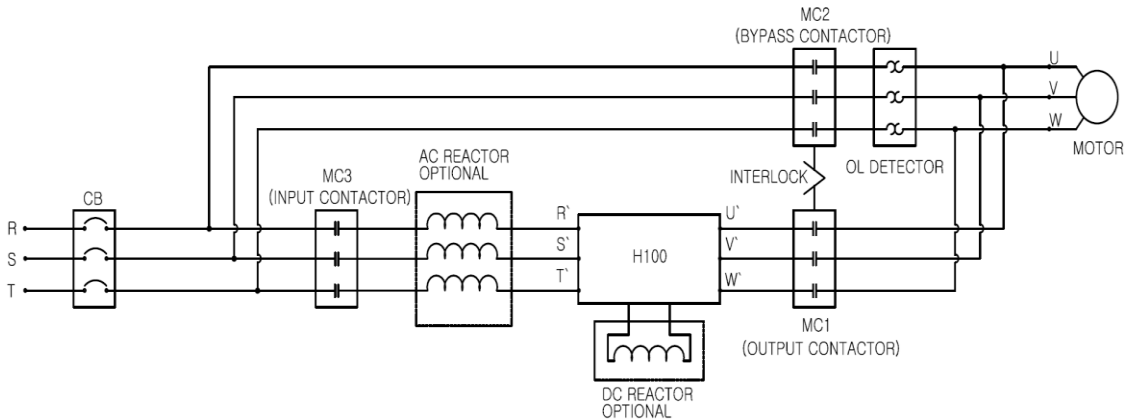

### Major parts labels and descriptions

Items	Name	Description
R, S, T	SP100 Line power input	3-phase AC line power supply to the adjustable frequency drive
U, V, W	SP100 Output to motor	Regulated 3-phase output power to the motor
R', S', T'	Inverter Line power input	No additional wiring is required
U', V', W'	Inverter Output to motor	No additional wiring is required
MC3	Input Contactor	Input Contactor for the inverter mode
MC2	Bypass Contactor	Bypass Contactor for the bypass mode
MC1	Output Contactor	Output Contactor for the inverter mode
AC Reactor (Optional)	AC Reactor	AC Reactor for the inverter mode
DC Reactor (Optional)	DC Reactor	DC Reactor for the inverter mode
CB	Manual Motor Starters or Molded Case Circuit Breakers	Circuit breaker for the SP100 input connections (200V Type : Manual Motor Starters 400V Type : Molded Case Circuit Breakers)

Items	Name	Description
OL Detector	Therminal Overload Relays	Protects inverter from motor overload

## 2 Installation Instruction

### 2.1 Installation Considerations

The table below details the ideal operation and installation conditions for the inverter.

Items	Description
Ambient Temperature	-10°C–40°C (14°F –104°F)
Ambient Humidity	90% relative humidity (no condensation)
Storage Temperature	-20°C–65°C (-4°F –149°F)
Environmental Factors	An environment free from corrosive or flammable gases, oil residue or dust
Altitude/Vibration	Lower than 3,280 ft (1,000 m) above sea level/less than 0.6 G (5.9 m/sec <sup>2</sup> )

### 2.2 Product Weight

The approximate weight of the SP100 products are as follows.

Frame Size	Weight in kg(lb)	
	DC Reactor (Optional)	AC Reactor (Optional)
A	17 (37.47)	19 (41.88)
B	37 (81.57)	38 (83.77)
C	44 (97.00)	45 (99.20)
D1 (37kW-4)	72 (158.73)	-
D2 (45kW,55kW-4)	82 (180.77)	-

#### Note

The actual weight may differ from the information above.

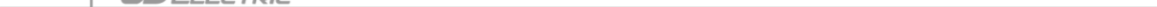
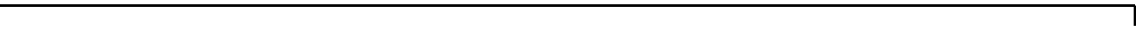

## 2.3 External Dimensions

### 5.5–30 kW (3-phase)

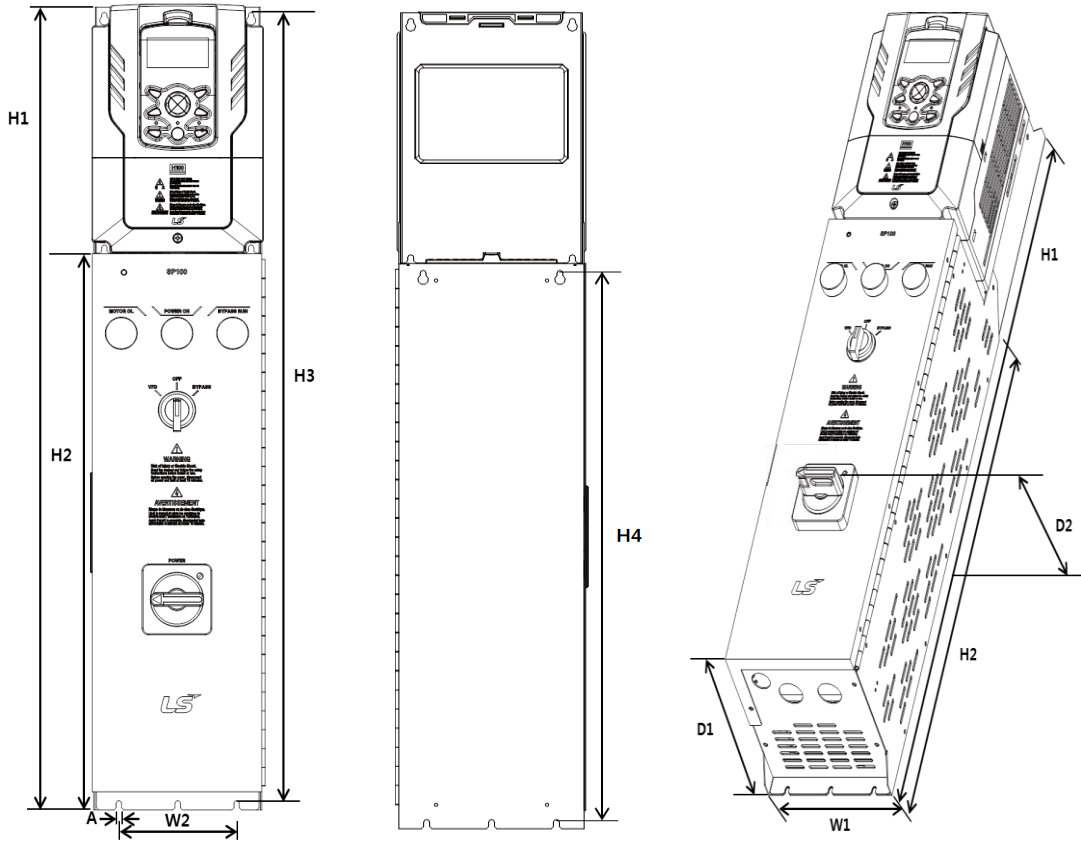

## 37–55 kW (3-phase)

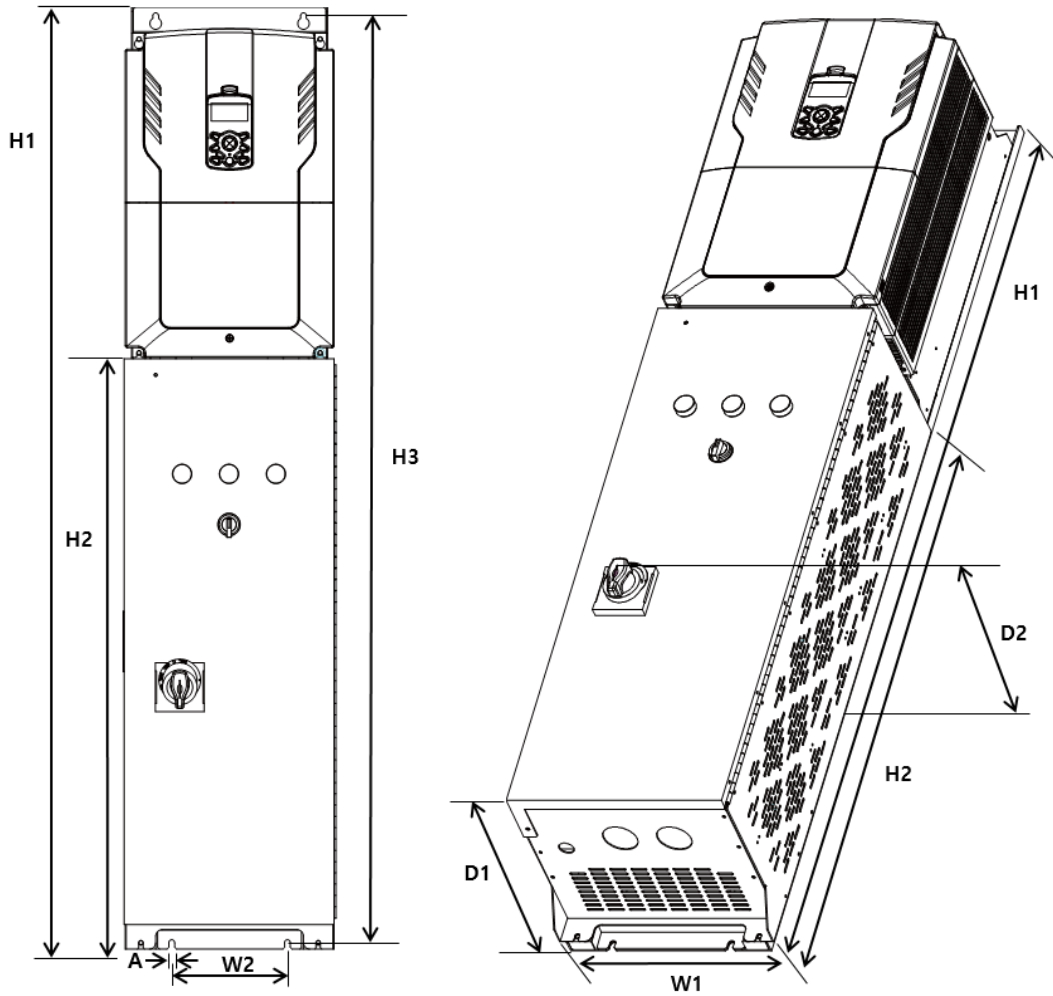

Units : mm

Items		W1	W2	H1	H2	H3	H4	D1	D2	A
3-phase 200 V	0055SP100-2	156.9	110.0	930.1	697.6	913.6	683.0	174.0	217.1	5.0
	0075SP100-2	156.9	110.0	930.1	697.6	913.6	683.0	174.0	217.1	5.0
	0110SP100-2	197.7	140.0	1178.7	866.7	1163.7	850.3	217.7	260.8	6.0
	0150SP100-2	197.7	140.0	1178.7	866.7	1163.7	850.3	217.7	260.8	6.0
	0185SP100-2	237.7	160.0	1312.0	941.2	1297.0	924.8	244.7	287.8	6.0
3-phase 400 V	0055SP100-4	156.9	110.0	930.1	697.6	913.6	683.0	174.0	217.5	5.0
	0075SP100-4	156.9	110.0	930.1	697.6	913.6	683.0	174.0	217.5	5.0
	0110SP100-4	156.9	110.0	930.1	697.6	913.6	683.0	174.0	217.5	5.0
	0150SP100-4	197.7	140.0	1178.7	866.7	1163.7	850.3	217.7	260.8	6.0
	0185SP100-4	197.7	140.0	1178.7	866.7	1163.7	850.3	217.7	260.8	6.0
	0220SP100-4	237.7	160.0	1312.0	941.2	1297.0	924.8	244.7	287.8	6.0
	0300SP100-4	237.7	160.0	1312.0	941.2	1297.0	924.8	244.7	287.8	6.0
	0370SP100-4	327.0	180.0	1460.0	915.4	1437.0	-	291.0	343.7	9.0
	0450SP100-4	327.0	180.0	1460.0	915.4	1437.0	-	291.0	343.7	9.0
	0550SP100-4	327.0	180.0	1460.0	915.4	1437.0	-	291.0	343.7	9.0

Units : inches

Items		W1	W2	H1	H2	H3	H4	D1	D2	A
3-phase 200 V	0055SP100-2	6.18	4.33	36.61	27.46	35.96	26.88	6.85	8.55	0.19
	0075SP100-2	6.18	4.33	36.61	27.46	35.96	26.88	6.85	8.55	0.19
	0110SP100-2	7.78	5.51	46.40	34.12	45.81	33.47	8.57	10.26	0.23
	0150SP100-2	7.78	5.51	46.40	34.12	45.81	33.47	8.57	10.26	0.23
	0185SP100-2	9.35	6.29	51.65	37.06	51.06	36.40	9.63	11.33	0.23
3-phase 400 V	0055SP100-4	6.18	4.33	36.61	27.46	35.96	26.88	6.85	8.56	0.19
	0075SP100-4	6.18	4.33	36.61	27.46	35.96	26.88	6.85	8.56	0.19
	0110SP100-4	6.18	4.33	36.61	27.46	35.96	26.88	6.85	8.56	0.19
	0150SP100-4	7.78	5.51	46.40	34.12	45.81	33.47	8.57	10.26	0.23
	0185SP100-4	7.78	5.51	46.40	34.12	45.81	33.47	8.57	10.26	0.23
	0220SP100-4	9.35	6.29	51.65	37.06	51.06	36.40	9.63	11.33	0.23
	0300SP100-4	9.35	6.29	51.65	37.06	51.06	36.40	9.63	11.33	0.23
	0370SP100-4	12.87	7.08	57.48	36.04	56.57	-	11.45	13.53	0.35

Items	W1	W2	H1	H2	H3	H4	D1	D2	A
0450SP100-4	12.87	7.08	57.48	36.04	56.57	-	11.45	13.53	0.35
0550SP100-4	12.87	7.08	57.48	36.04	56.57	-	11.45	13.53	0.35

## 2.4 Cable Selection

When you install power and signal cables in the terminal blocks, only use cables that meet the required specification for the safe and reliable operation of the product. Refer to the following information to assist you with cable selection.

### ⚠ Caution

- Wherever possible use cables with the largest cross-sectional area for mains power wiring, to ensure that voltage drop does not exceed 2%.
- Use copper cables rated for 600 V, 75°C for power terminal wiring.
- Use copper cables rated for 300 V, 75°C for control terminal wiring.
- The inverters in the range between 15 and 55 kW must be grounded conveniently with fixed connections.
- The inverters in the range between 5.5kW and 11kW must be grounded with and industrial connector according to IEC 60309.
- The minimum size of the protective earthing conductor shall comply with the local safety regulations for high protective earthing conductor current equipment.
- Only one conductor per terminal should be simultaneously connected

### Ground Cable and Power Cable Specifications

Load (kW)		Ground Wire		Input/Output Power Wire			
		mm <sup>2</sup>	AWG	mm <sup>2</sup>		AWG	
				R/S/T	U/V/W	R/S/T	U/V/W
3-phase 200 V	5.5	10	10	4	4	12	12
	7.5			6	6	10	10
	11			10	10	8	8
	15	14	6	16	16	6	6
	18.5			25	22	4	4
3-phase 400 V	5.5	4	12	2.5	2.5	14	14
	7.5			4	2.5	12	14
	11			4	4	12	12
	15	16	9	6	6	10	10
	18.5			16	10	6	8

Load (kW)		Ground Wire		Input/Output Power Wire			
	22	14	6	16	10	6	8
	30			25	16	4	6
	37	25	4	25	25	4	4
	45			25	25	4	4
	55			50	50	1/0	1/0

### Signal (Control) Cable Specifications

Terminals	Wire thickness <sup>1)</sup>	
	mm <sup>2</sup>	AWG
P1–P7/CM/VR/V1/I2/24/TI	0.33–1.25	16–22
AO1/AO2/CM/Q1/EG	0.33–2.0	14–22
A1/B1/C1/A2/C2/A3/C3/A4/C4/A5/C5	0.33–2.0	14–22
S+,S-,SG	0.75	18

1) Use STP (shielded twisted-pair) cables for signal wiring.

### Note

- Use STP (Shielded Twisted Pair) cables to connect a remotely located motor with the inverter. Do not use 3 core cables.
- Make sure that the total cable length does not exceed 492 ft (150 m). For inverters < = 3.7 kW capacity, ensure that the total cable length does not exceed 165 ft (50 m).
- Long cable runs can cause reduced motor torque in low frequency applications due to voltage drop. Long cable runs also increase a circuit's susceptibility to stray capacitance and may trigger over-current protection devices or result in malfunction of equipment connected to the inverter.
- Voltage drop is calculated by using the following formula:
- Voltage Drop (V) = [ $\sqrt{3}$  X cable resistance (mΩ/m) X cable length (m) X current (A)] / 1000
- Use cables with the largest possible cross-sectional area to ensure that voltage drop is minimized over long cable runs. Lowering the carrier frequency and installing a micro surge filter may also help to reduce voltage drop.

Distance	< 165 ft (50 m)	< 330 ft (100 m)	> 330 ft (100 m)
Allowed Carrier Frequency	<15 kHz	<5 kHz	<2.5 kHz

 Warning

Do not connect power to the inverter until installation has been fully completed and the inverter is ready to be operated. Doing so may result in electric shock.

## 2.5 Peripheral Devices

### Compatible Circuit Breaker Models (manufactured by LS ELECTRIC)

Product (kW)		3Phase 200V				
		5.5	7.5	11	15	18.5
Circuit Breaker	Model	UTE100				UTS150
	Rated Current	50	60	100	100	150

Product (kW)		3Phase 200V						
		5.5	7.5	11	15	18.5	22	30
Circuit Breaker	Model	UTE100					UTS150	
	Rated Current	50	50	60	80	100	125	125

Maximum allowed prospective short-circuit current at the input power connection is defined in IEC 60439-1 as 100 kA. LSLV-H100 is suitable for use in a circuit capable of delivering not more than 100kA RMS at the drive's maximum rated voltage, depending on the selected MCCB. RMS symmetrical amperes for recommended MCCB are the following table.

Working Voltage	UTE100 (E/N)	UTS150 (N/H/L)	UTS250 (N/H/L)	UTS400 (N/H/L)
240V(50/60Hz)	50/65kA	65/100/150kA	65/100/150kA	65/100/150kA
480V(50/60Hz)	25/35kA	35/65/100kA	35/65/100kA	35/65/100kA

## 2.6 Terminal Screw Specifications

### Input/Output Terminal Screw Specification

Product (kW)		Terminal Screw Size	Screw Torque (lbf·in / Nm)
3-Phase 200 V	5.5	M5	28.2~36.6 / 2.4~3.1
	7.5		
	11		
	15		
	18.5		
3-Phase 400 V	5.5	M5	28.2~36.6 / 2.4~3.1
	7.5		
	11		
	15		
	18.5		
	22	M8	70.5~105.8 / 6~9
	30		
	37		
	45		
55			

#### ⓘ Caution

Apply rated torques to the terminal screws. Loose screws may cause short circuits and malfunctions. Tightening the screw too much may damage the terminals and cause short circuits and malfunctions. Use copper wires only with 600V, 90°C rating for the power terminal wiring, and 300V, 75°C rating for the control terminal wiring.

## 2.7 Cable Wiring

### Wiring requirements

Refer to "2.3 Cable Wiring" in the LSLV-H100 User Manual. All requirements are same as LSLV-H100 products.

- 1 Loosen the front fixing bolt and the bottom fixing bolt, turn the switch to OFF position, and then open the cover of SP100.

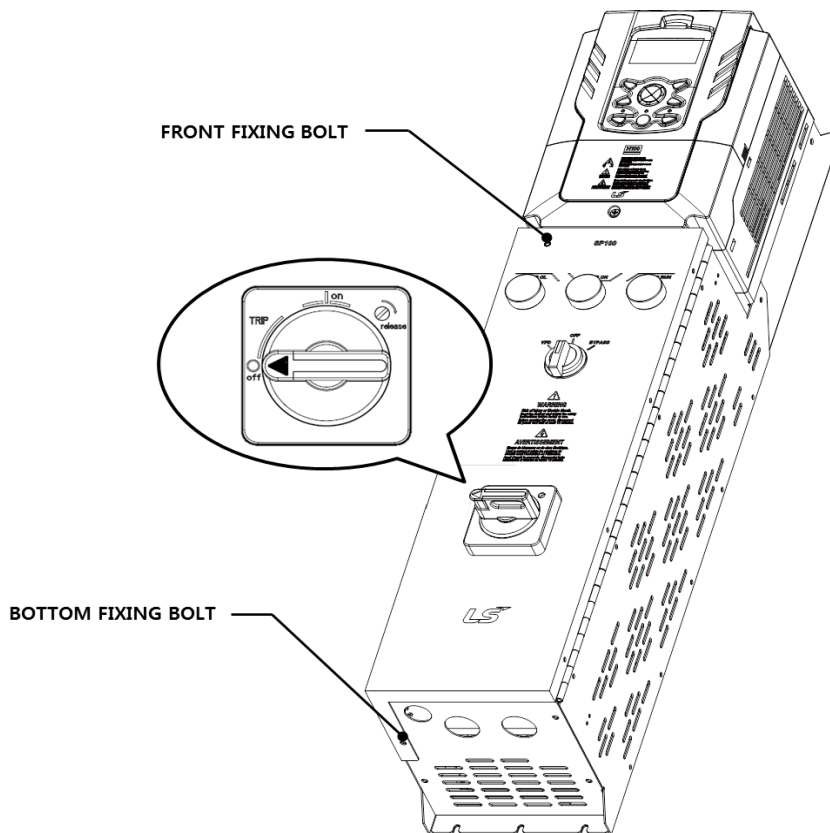

### ⓘ Caution

- The cover will not open if the position of the power switch is set to ON.
- Use cover handle at the left side when opening the cover. Holding the power switch when opening the cover may damage the SP100.

- 2 Remove the power terminal cover, and then connect the R/S/T input powers to the U/V/W motor output terminals.

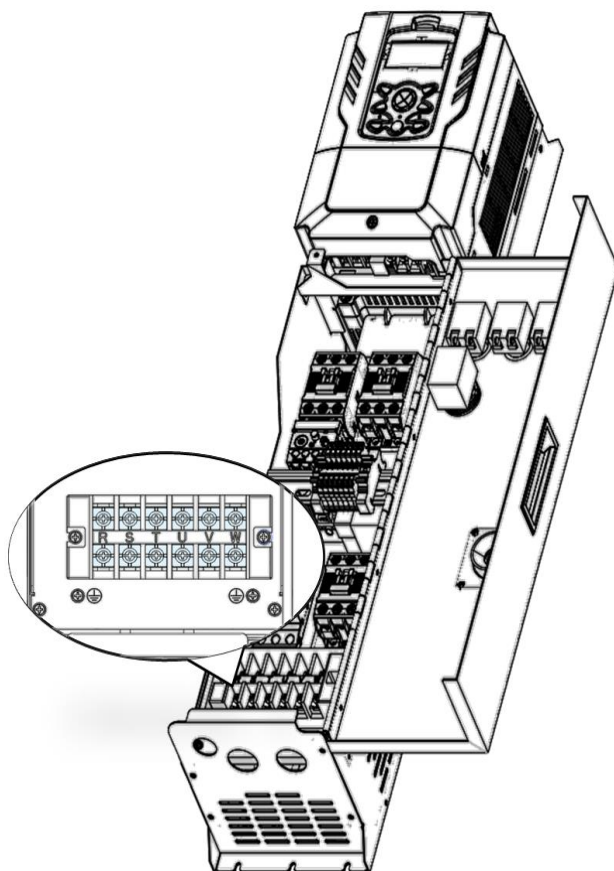

- 3 Connect the ground cables that are appropriate for your motor capacity to the ground terminals.

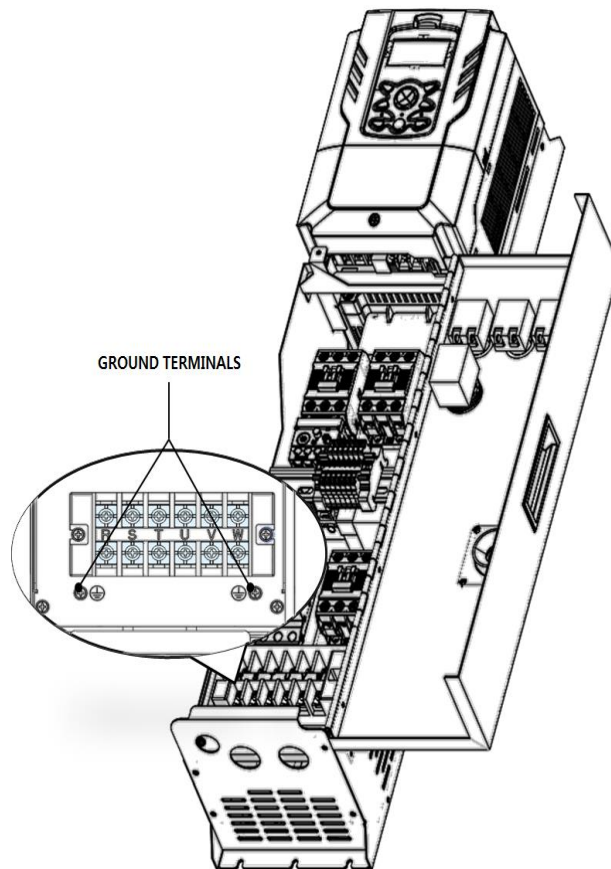

#### Note

- 200 V products require Class 3 grounding. Resistance to ground must be  $\leq 100 \Omega$ .
- 400 V products require Special Class 3 grounding. Resistance to ground must be  $\leq 10 \Omega$ .
- Keep the ground wire connections as short as possible.
- Do not ground one inverter to another in a “daisy chain” fashion.
- Follow the motor manufacturer wiring requirements.

#### Warning

Install ground connections for the inverter and the motor by following the correct specifications to ensure safe and accurate operation. Using the inverter and the motor without the specified grounding connections may result in electric shock.

## 2.8 Configuration and Wiring of Input/Output Control Terminal

The following diagram shows arrangement and configuration of the control terminal. Before wiring the control terminal, make sure that the cables you are using meets the requirements.

### Input and Output Control Terminal Block Wiring Diagram

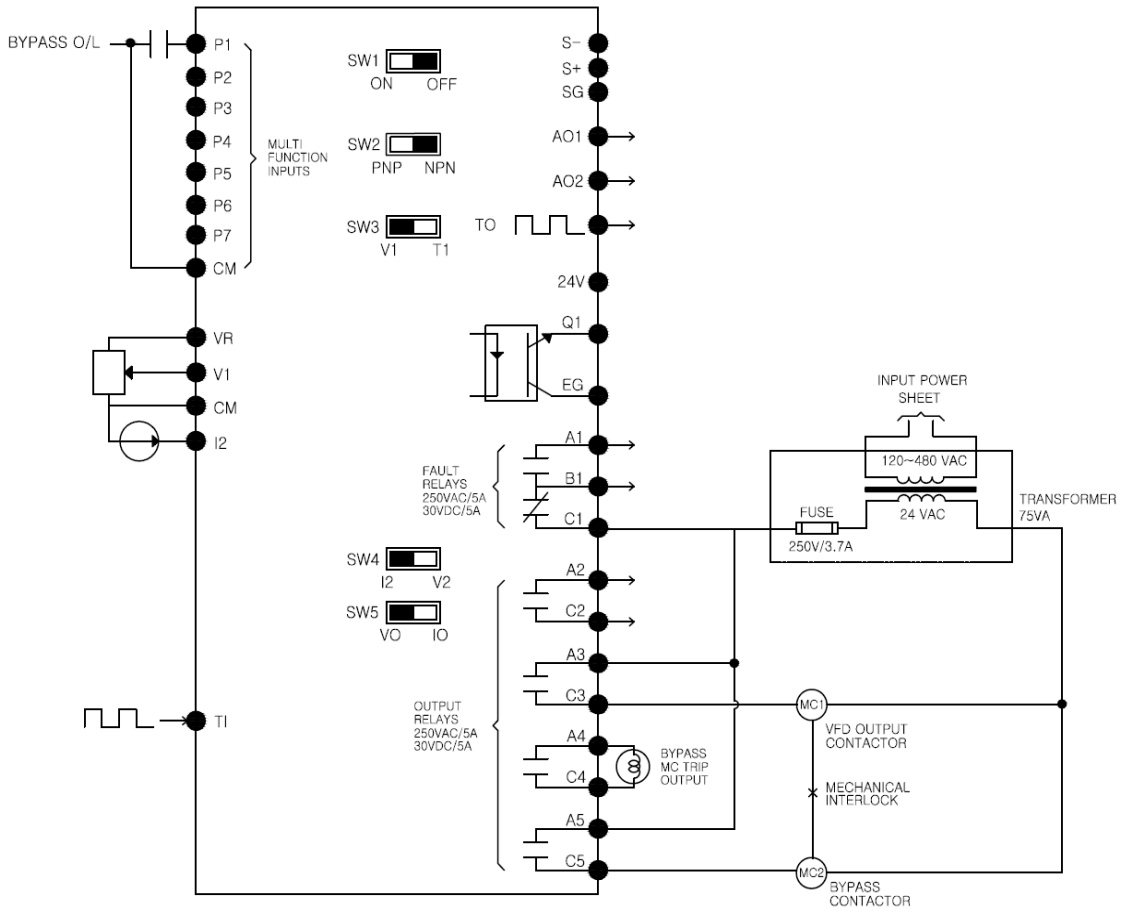

#### Note

Do not change the pre-connected control wiring because it is connected to the software. Use terminals that are not assigned when connecting additional control wires.

## Control Terminal Block Labels and Descriptions

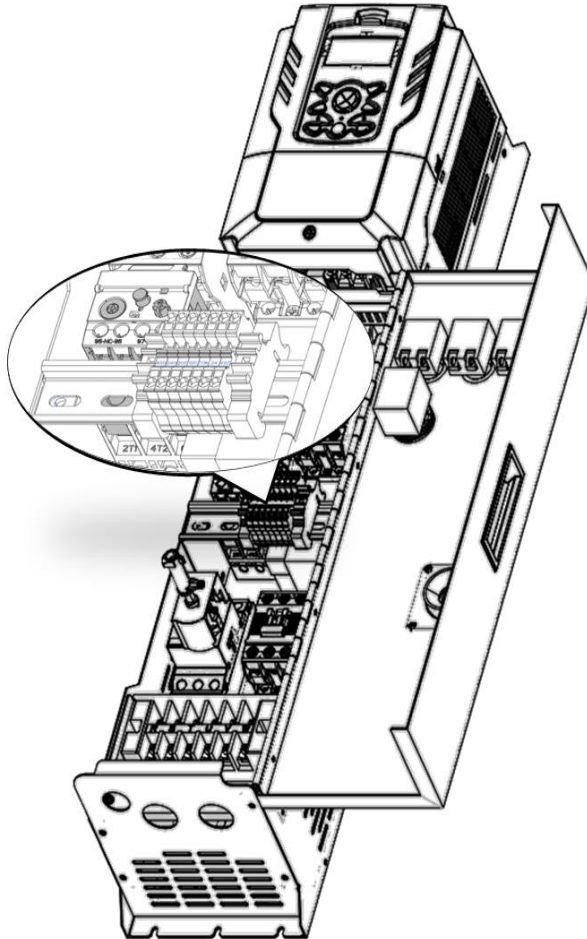

Terminal name	Description
480	Transformer AC 480 V Input
240	Transformer AC 240 V Input
A	Transformer AC 240 V Output
208	Transformer AC 208 V Output
120	Transformer AC 120 V Input (Not used)
COM	Transformer AC Common Input (Input T phase)
B	Transformer AC Common Output
24	Transformer AC 24 V Input

Terminal name	Description
VAC	Transformer AC Common Output for internal MC coil

#### Note

- When using 200V, 400 V products, use the default control wiring that is set to A according to the commercial voltage, and change to the 208 control terminal when using the voltage over 240V, 480 V
- While making wiring connections at the control terminals ensure that the total cable length does not exceed 165 ft (50 m).
- Ensure that the length of any safety related wiring does not exceed 100 ft (30 m).
- Use ferrite material to protect signal cables from electro-magnetic interference.
- Use caution when handling the internal control transformer input (480/240/A/208/B/120 /COM) to prevent electric shock because it is connected to the system power plug.

## 2.9 Configuration and Descriptions of Indicators and Switches

See the names and functions of indicators and switches of SP100.

### Indicators and switches

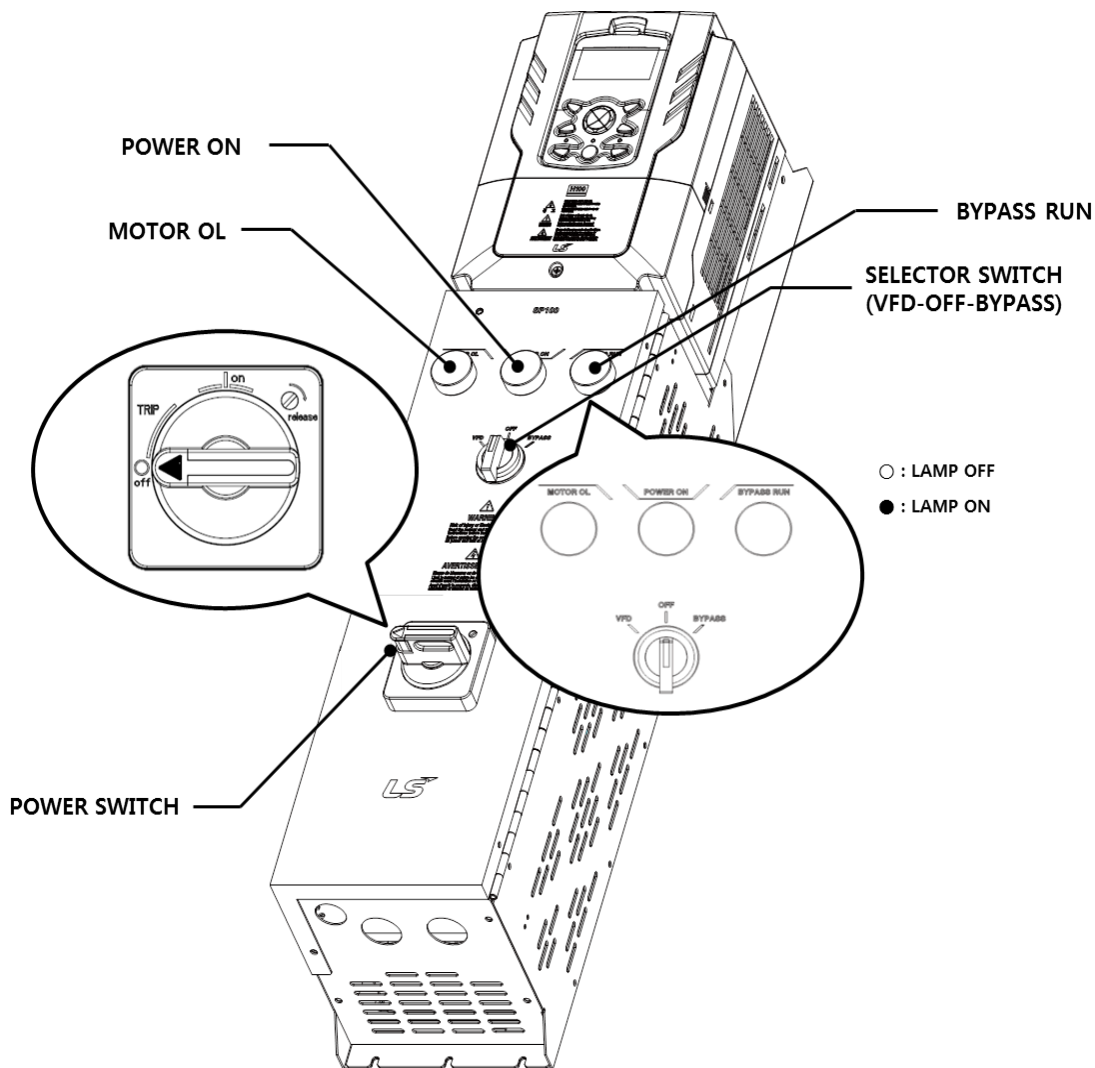

## Functions of indicators and switches

- When the power switch and selector switch are OFF

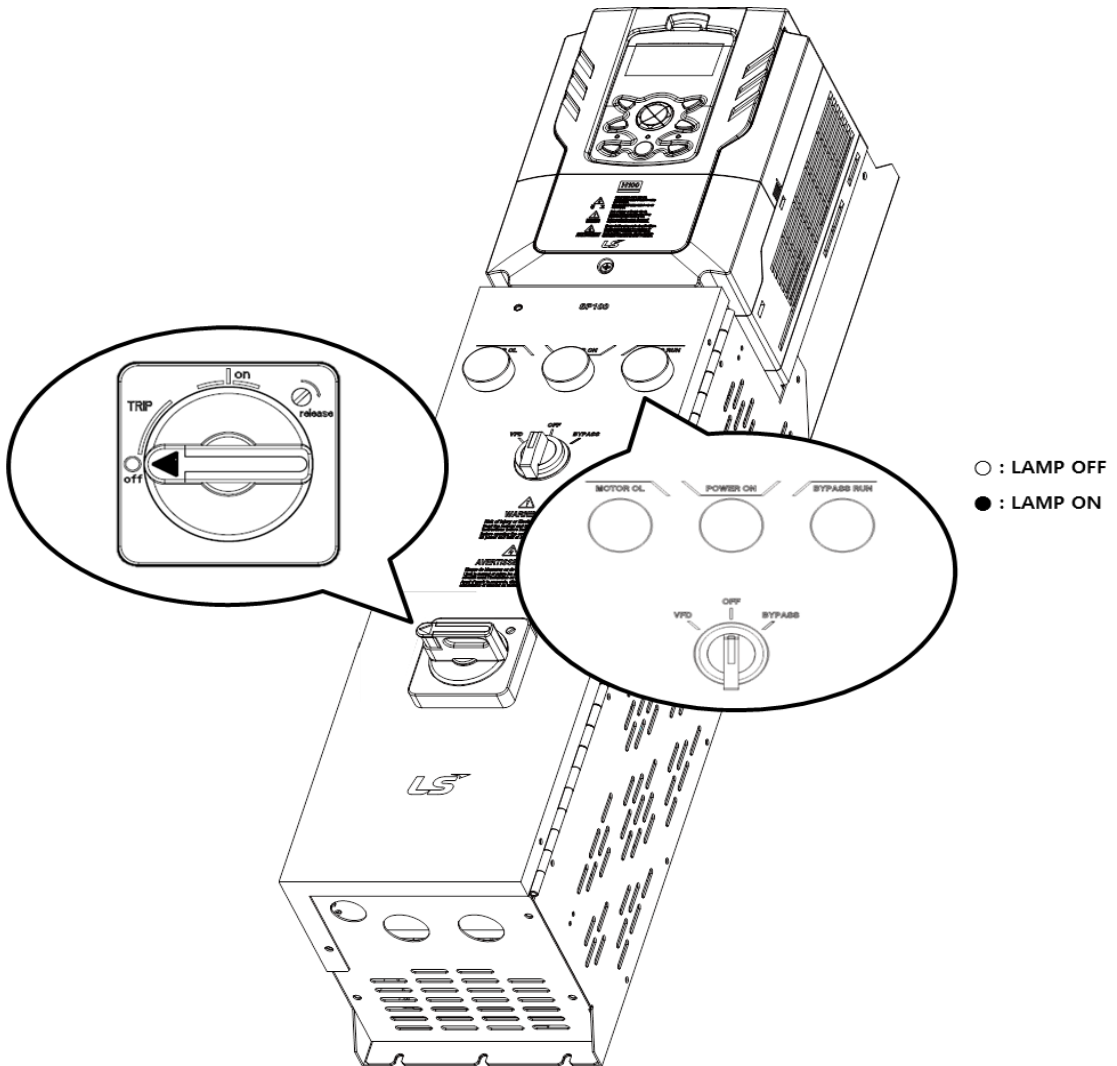

Switch position		Indicator			Description
POWER	SELECTOR	MOTOR OL	POWER ON	BYPASS RUN	
OFF	OFF	OFF	OFF	OFF	The power is OFF. No function is available.

■ When the power switch is ON and the selector switch is OFF

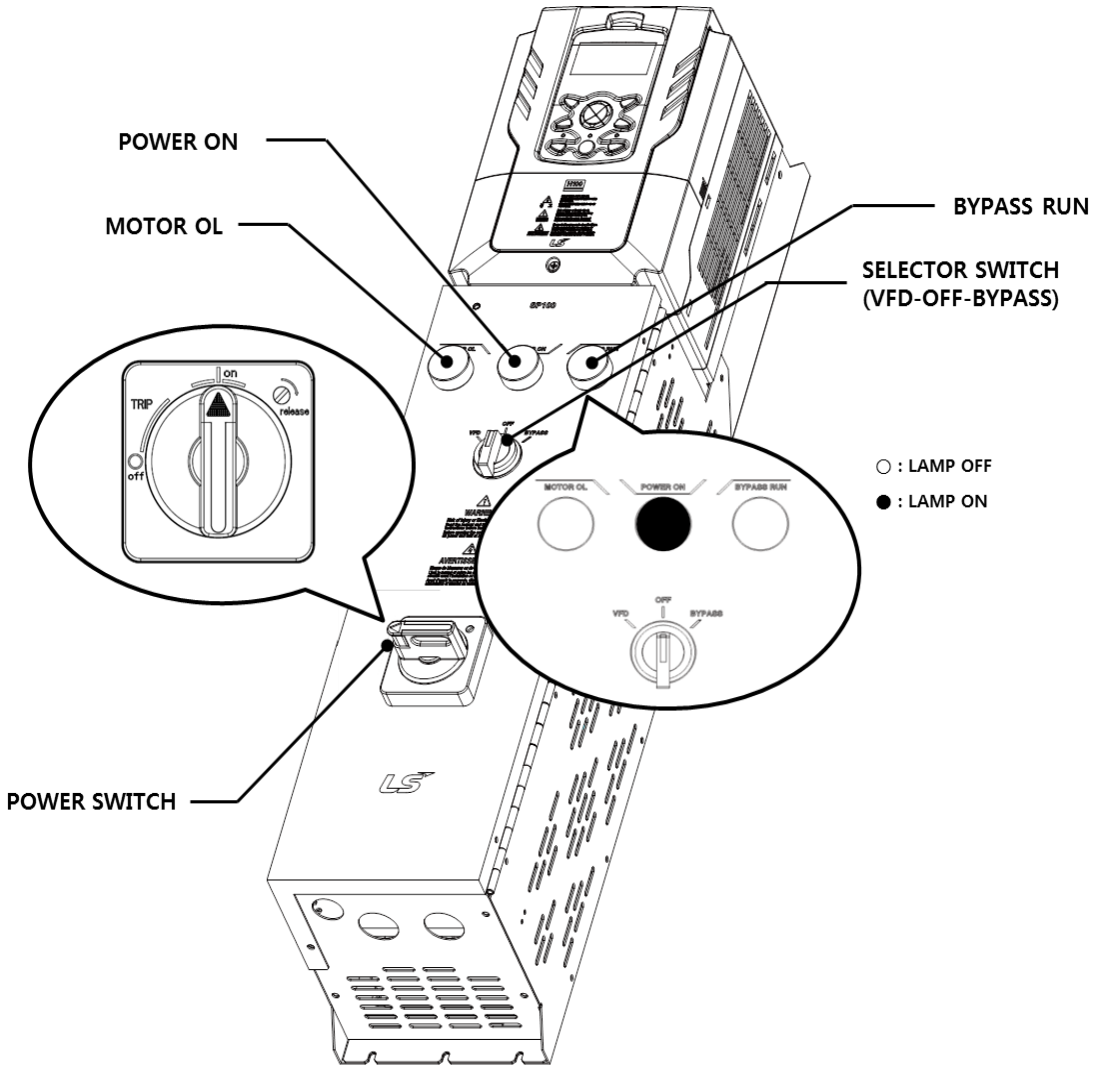

Switch position		Indicator			Description
POWER	SELECTOR	MOTOR OL	POWER ON	BYPASS RUN	
ON	OFF	OFF	ON	OFF	The power is ON. Use selector switch to change modes between the inverter mode and the manual bypass mode.

When the power switch is ON and the selector switch is VFD

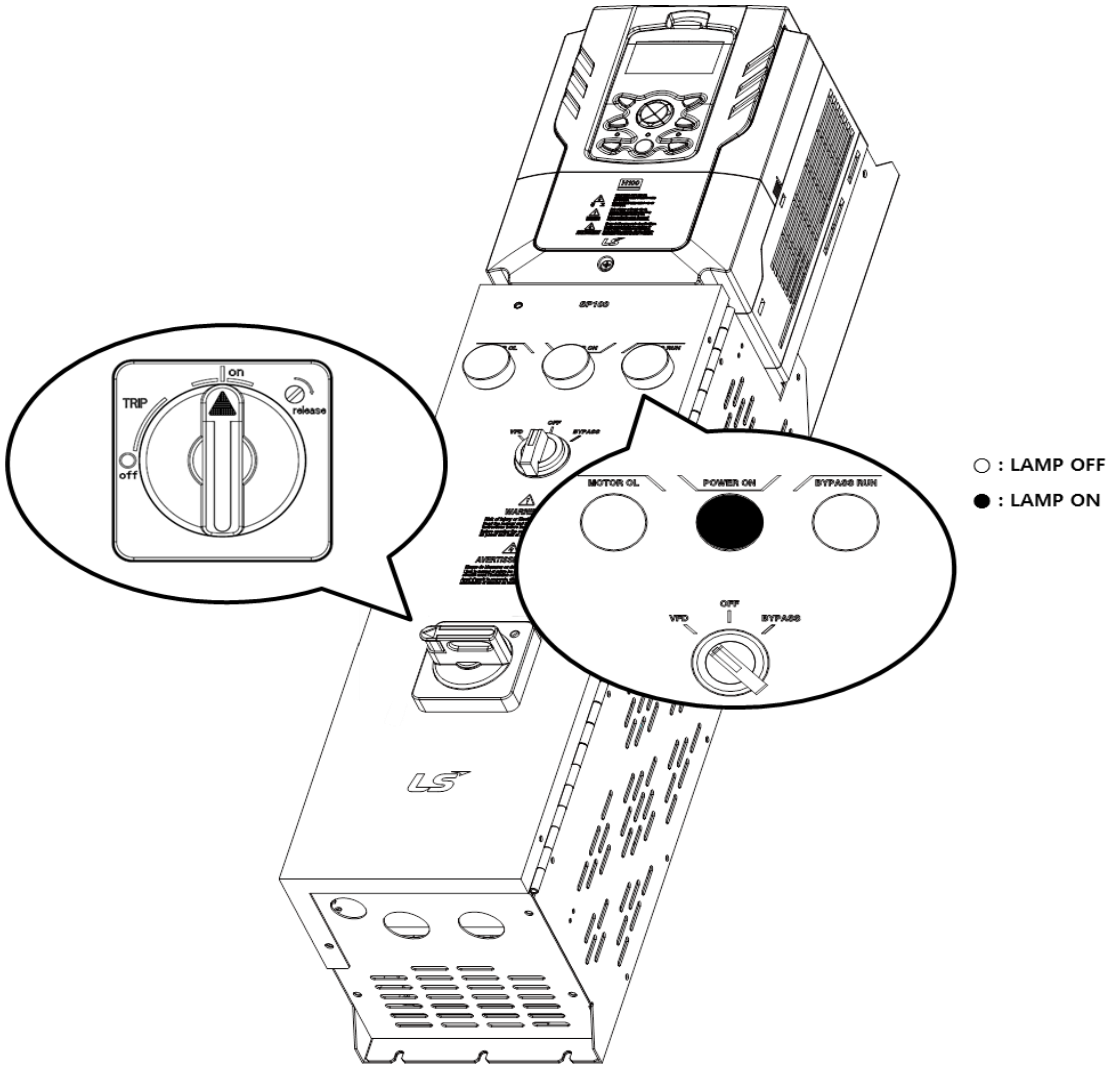

Switch position		Indicator			Description
POWER	SELECTOR	MOTOR OL	POWER ON	BYPASS RUN	
ON	VFD	OFF	ON	OFF	The power is ON. The inverter mode is available.

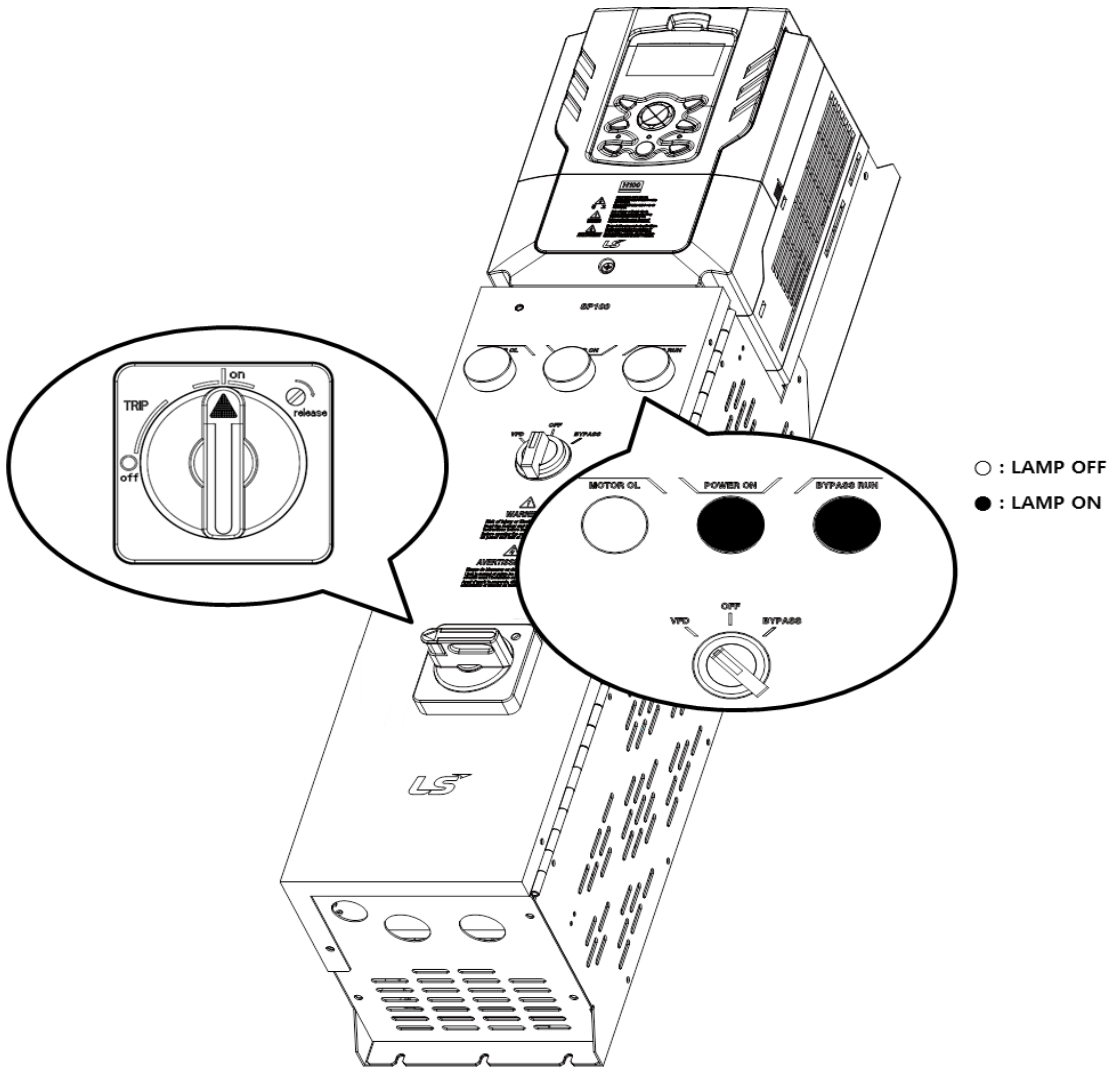

Switch position		Indicator			Description
POWER	SELECTOR	MOTOR OL	POWER ON	BYPASS RUN	
ON	VFD	OFF	ON	ON	Bypass operation via the inverter mode is available.

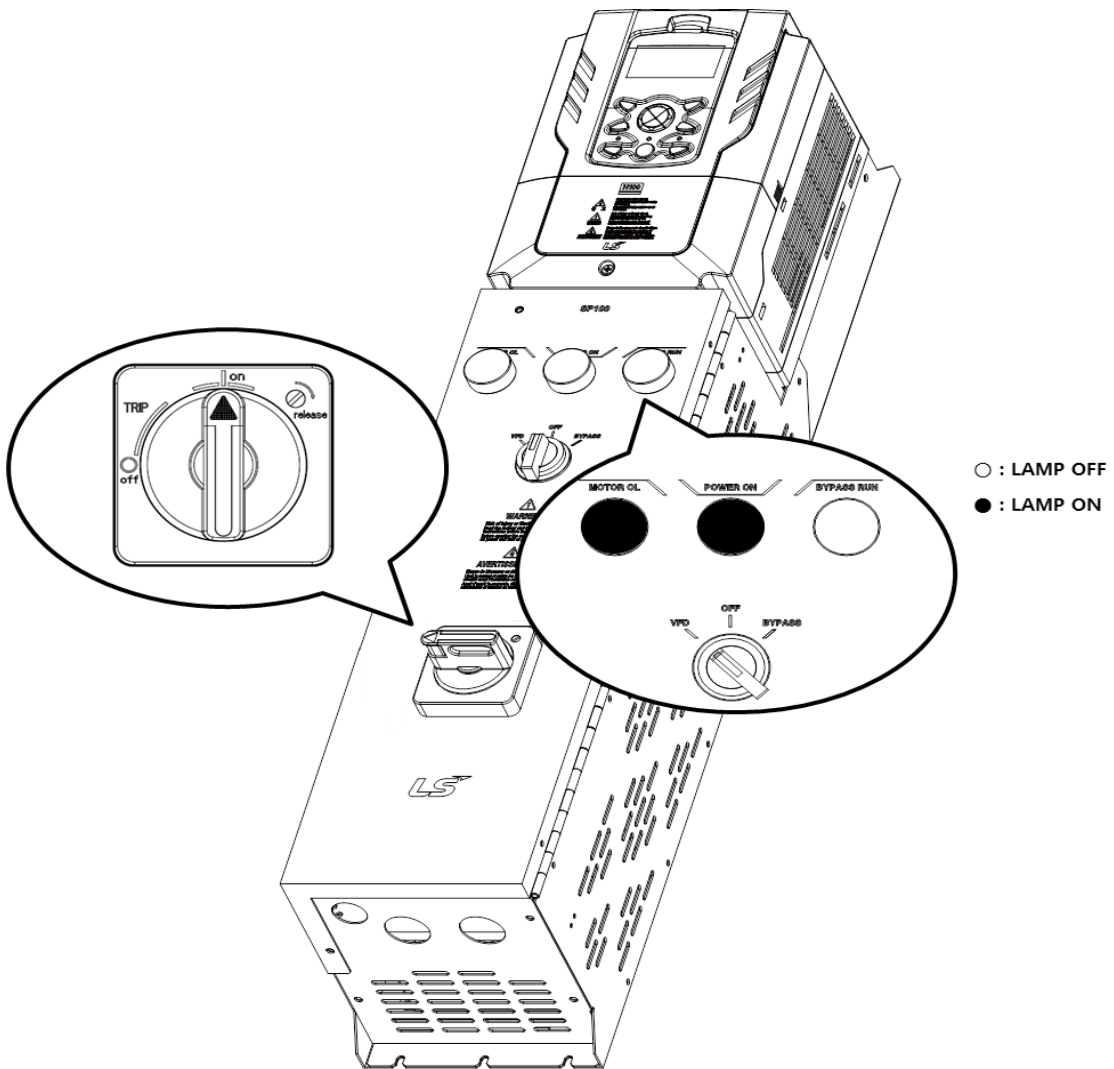

Switch position		Indicator			Description
POWER	SELECTOR	MOTOR OL	POWER ON	BYPASS RUN	
ON	VFD	ON	ON	OFF	The MOTOR OL trip occurred during the bypass operation via the inverter mode.

■ When the power switch is ON and the selector switch is BYPASS

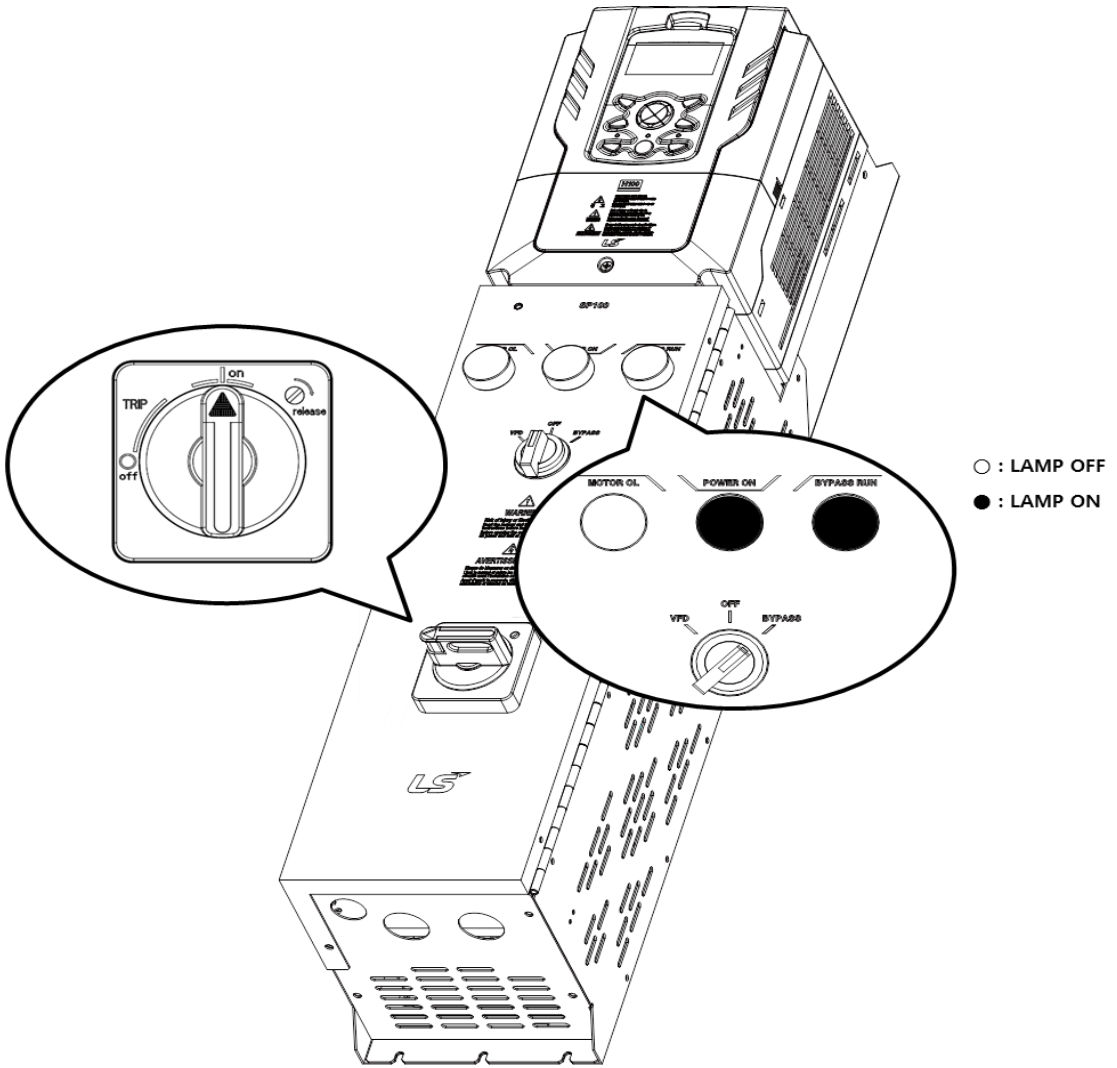

Switch position		Indicator			Description
POWER	SELECTOR	MOTOR OL	POWER ON	BYPASS RUN	
ON	BYPASS	OFF	ON	ON	The power is OFF. Manual bypass operation by the selector switch is available.

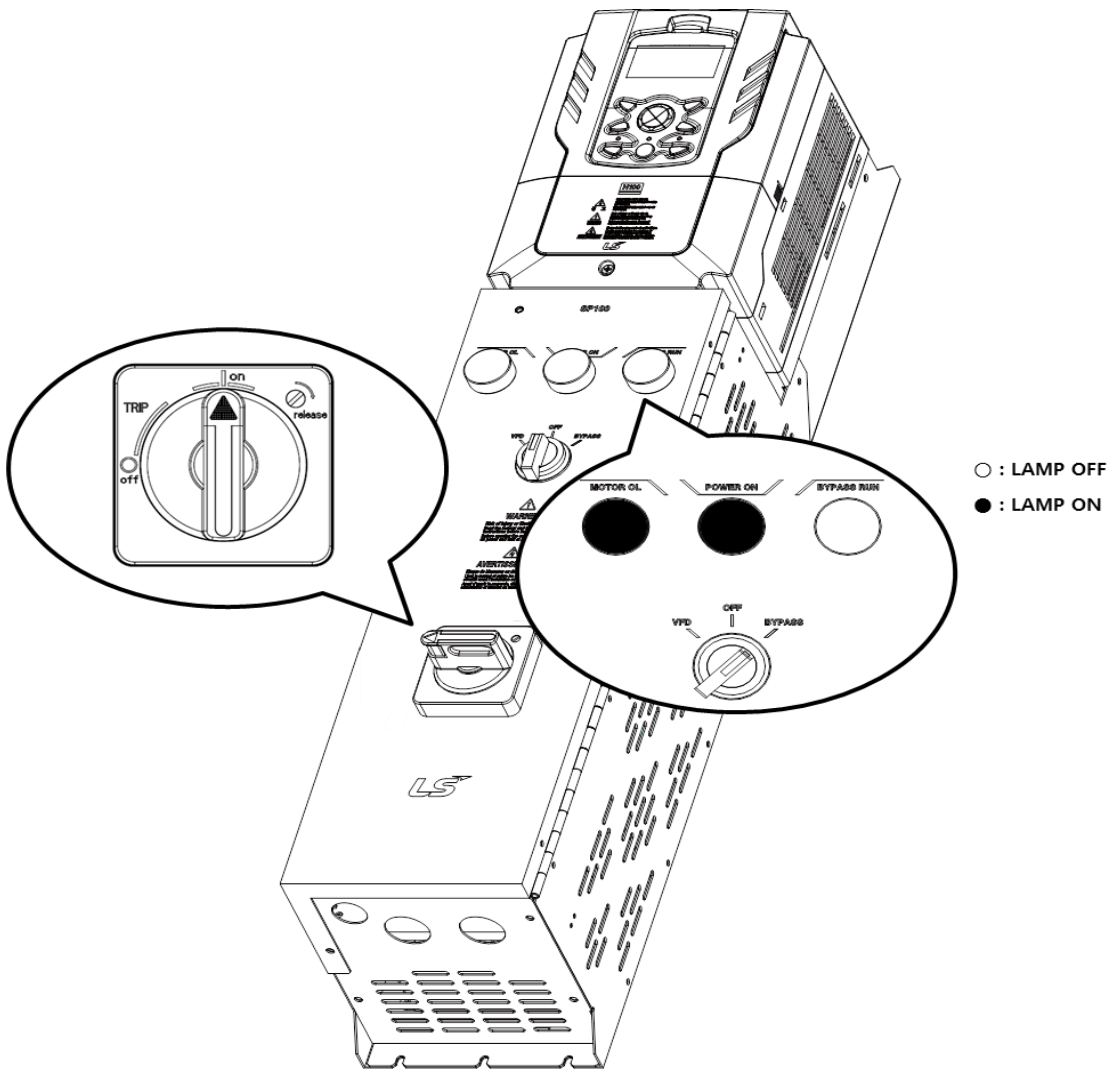

Switch position		Indicator			Description
POWER	SELECTOR	MOTOR OL	POWER ON	BYPASS RUN	
ON	BYPASS	ON	ON	OFF	The MOTOR OL trip occurred during the manual bypass operation by the selector switch.

## Note

The power switch can be locked when it is set to ON or OFF position.

- ① Turn the handle to set to the right position.

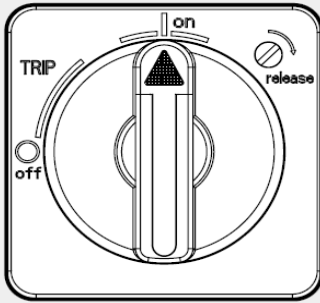

On Position  
(Vertical State)

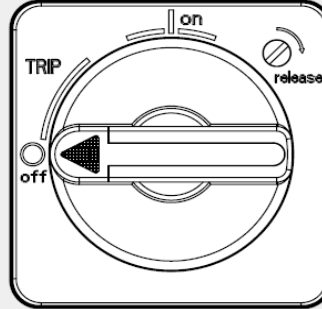

Off Position  
(Horizontal State)

- ② Pushing

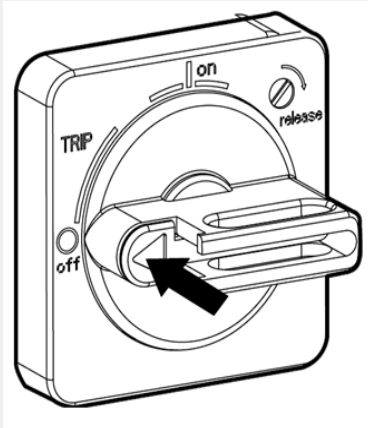

- ③ Locking

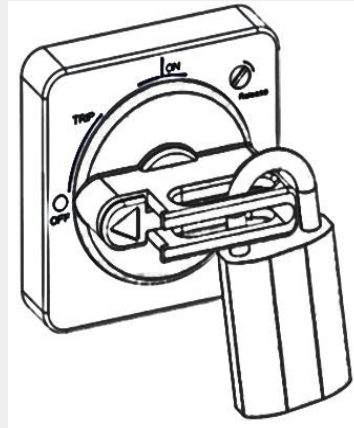

## 3 Start-Up Procedure

### 3.1 Test Run

#### Before connecting the power

- 1 Make sure that the cover is closed.
- 2 Make sure that power switch and selector switch are OFF.
- 3 Make sure that the SP100 and the motor is grounded properly.
- 4 Make sure that the cable sizes for the input power and motor are proper.
- 5 Make sure that the input power and motor cable are connected safely.
- 6 Make sure that the control wiring is connected correctly.
- 7 Make sure that the control shield cable is grounded properly.
- 8 Make sure that the control cable and power cable are connected separately.

#### ⚠ Caution

- The inverters contain high voltage when connected to AC line power. Installation, start-up, and maintenance must be performed by qualified personnel only. Failure to perform installation, start-up, and maintenance by qualified personnel could result in death or serious injury.
- When using 200V, 400 V products, use the default control wiring that is set to A according to the commercial voltage, and change to the 208 control terminal when using the voltage over 240V, 480 V.
- We recommend that user change values of over-current detecting level, timing, correctly with GMP manual because current values of Circuit Breaker and OL Detector are set randomly.

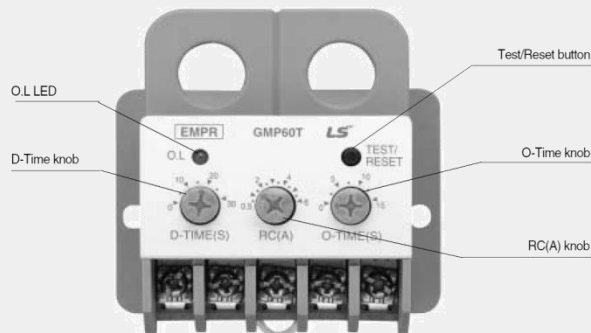

## 1 Set the Operating time

- D-Time (Delay Time) : 0~30 sec

The motor starting current, which flows when the motor is starting, is generally 600% of the rated current. It is the time during which the GMP do not operated by over-current during the starting time.

- 1) Set the delay time by use of the 'D-Time' knob.
- 2) In case you do not know the delay time, start the motor by setting the 'D-time' knob to the max. Position and after checking the time during which the starting current become stable, set the D-time.

- O-Time (Operating Time) : 0~15 sec

The operating time is the time during which the GMP tripped by the over-current. The GMP is tripped after the selected operation time.

- 1) Set the operation time by the 'O-Time' knob.
- 2) If you set the 'O-Time' to the in value, the GMP is tripped at once.

## 2 Set the operating current

- 1) Start the motor by setting the 'RC' knob to the maximum position.
- 2) Under operating condition, rotate the 'RC' knob to the counterclockwise until the 'O.L.' LED turned on & off. The current at this point is the value (100%) under real load condition.
- 3) Rotate the 'RC' knob to the clock-wise until the 'O.L.' LED turned off.  
(Ex. When the 'O.L.' LED flickering at 20A, the setting current will be 22A(=20x1.1)  
(In case of setting RC knob value of GMP, please be careful because it has allowable error( $\pm 8\%$ )).

Model (kW)		Initial Value (A)	Setting Range (A)	Tolerance	Description
3-Phase 200V	5.5	30	5~60	Current : $\pm 8\%$ Time : $\pm 5\%$	The detection level is the value set by the 1:1 CT overload detection method.
	7.5	35			
	11	2.5	0.5~6		The detection level is 20 times of the value set by 20:1 CT overload detection method.
	15	3			
	18.5	4			
3-Phase 400V	5.5	15	3~30		The detection level is the value set by the 1:1 CT overload detection method.
	7.5	20			
	11	30	5~60		The detection level is 20 times of the value set by 20:1 CT overload detection method.
	15	2	0.5~6		
	18.5	2			
	22	3			
	30	3.5			
	37	4			
	45	3.5			
55	4		The detection level is 30 times of the value set by 30:1 CT overload detection method.		

Ex) In the case of 20:1 CT detection system, if you set the RC knob to 3A, it detects overload when 60A or more of the current flows that is 20 times of the setting value.

---

### **When the power is connected**

- 1 Make sure that the power on lamp is ON when the power switch is set to ON.
- 2 Make sure that the VFD power is ON when the selector switch is set to VFD.
- 3 Make sure that the motor rotates counterclockwise when operating the motor in a low frequency using the Hand mode of the keypad.
- 4 Make sure that the VFD power is OFF when the selector switch is set to OFF.
- 5 Make sure that the motor is stopped.
- 6 Make sure that the bypass run lamp is ON when the selector switch is set to BYPASS.
- 7 Make sure that the motor rotates counterclockwise.
- 8 Make sure that the motor is stopped when the selector switch is set to OFF.
- 9 Turn the selector switch to VFD and then configure the parameters regarding the bypass. (Refer to 3.2 Parameter Settings)

### **Note**

Make sure that the order of power connection and the power conditions (R/S/T) are correct if rotation directions of the motor during the inverter operation and in the manual bypass mode are different.

## 3.2 Parameter Settings

To use functions of this product, you must select the desired group and code and set the proper parameter values using the keypad. To locate the desired function, refer to the product manual.

### 3.2.1 Table of Functions

\*O : Write-enabled during operation, Δ : Write-enabled when operation stops, X: Write-disabled

Code	Comm. Address	Name	LCD Display	Parameter Setting	Initial Value	Property
AP2-61	0h1B3D	Bypass → inverter operation delay time	BPBack InlineT	AP2-61– 999.9 (sec)	5.0	Δ
AP2-62	0h1B3E	Bypass MC delay time	BY-Pass MC del	0.5–999.9 (sec)	2.0	Δ
AP2-63	0h1B3F	Bypass operation selection	Bypass	0 : No 1 : Yes	No	O
AP2-64	0h1B40	Automatic bypass when a fault trip occurs	FLT AT ByPass	0 : No 1 : Yes	No	Δ
AP2-65	0h1B41	Automatic bypass target fault selection	Select FLT	0000–1111	0000	O
AP2-66	0h1B42	Bypass switch during the inverter operation selection	INV Op ByPass	0 : No 1 : Yes	No	Δ
IN-65	0h1541	Multi-function input terminal, Bypass MC Trip	P1 define	0–57	Bypass MC Trip	Δ
IN-66–71	0h1542– 0h1547	Multi-function input terminal,, Exchange	Px define (Px: P2–P7)	0–56	-	Δ
OUT-33	0h1621	Multi-function relay, Inverter Line	Relay3	0–41	Inverter Line	O
OUT-34	0h1622	Multi-function relay, Bypass MC TRIP	Relay4	0–41	Bypass MC TRIP	O
OUT-35	0h1623	Multi-function relay, Comm Line	Relay5	0–41	Comm Line	O
CNF-42	-	Multi key item	Multi-Key Sel	0 : None 1 : UserGrp SelKey 2: Bypass	None	O

※ Keypad bypass operation is available by assigning the multi key function.

※ Bypass operation via the inverter mode is available in the AUTO and HAND modes, and only the manual bypass operation is available in the OFF mode.

### 3.2.2 Functions of SP100

Code	Description								
AP2-61 BPBack InlineT	<p>Sets the delay time when switching to the inverter operation during the bypass operation via the inverter mode.</p> <ul style="list-style-type: none"> <li>Set the proper delay value because over current trip or over voltage trip may occur when switching to the inverter operation depending on the amount of load.</li> </ul>								
AP2-62 BY-Pass MC del	Sets the delay time when switching to the bypass operation during the inverter operation via the inverter mode.								
AP2-63 Bypass	<p>Selects the bypass operation.</p> <table border="1"> <tr> <td>No</td> <td>Switches to the inverter mode.</td> </tr> <tr> <td>Yes</td> <td>Switches to the bypass operation via the inverter mode.</td> </tr> </table>	No	Switches to the inverter mode.	Yes	Switches to the bypass operation via the inverter mode.				
No	Switches to the inverter mode.								
Yes	Switches to the bypass operation via the inverter mode.								
AP2-64 FLT AT Bypass	<p>Selects whether or not automatically switch to the bypass operation via the inverter mode when faults set in AP2-65 occur.</p> <table border="1"> <tr> <td>No</td> <td>Does not automatically switch to the bypass operation when a fault occurs during inverter operation.</td> </tr> <tr> <td>Yes</td> <td>Automatically switches to the bypass operation when a fault occurs during inverter operation.</td> </tr> </table>	No	Does not automatically switch to the bypass operation when a fault occurs during inverter operation.	Yes	Automatically switches to the bypass operation when a fault occurs during inverter operation.				
No	Does not automatically switch to the bypass operation when a fault occurs during inverter operation.								
Yes	Automatically switches to the bypass operation when a fault occurs during inverter operation.								
AP2-65 Select FLT	<p>Selects faults to automatically switch to the bypass operation when a fault occurs during inverter operation. (By Bits)</p> <table border="1"> <tr> <td>Bit 0</td> <td>Over Current 1</td> </tr> <tr> <td>Bit 1</td> <td>Over Current 2</td> </tr> <tr> <td>Bit 2</td> <td>Lost Command</td> </tr> <tr> <td>Bit 3</td> <td>Over Voltage</td> </tr> </table>	Bit 0	Over Current 1	Bit 1	Over Current 2	Bit 2	Lost Command	Bit 3	Over Voltage
Bit 0	Over Current 1								
Bit 1	Over Current 2								
Bit 2	Lost Command								
Bit 3	Over Voltage								
AP2-66 INV Op Bypass	Does not switch to the bypass operation during the inverter operation if the bypass operation selection parameter is set to No (default).								
IN-65 P1 define	Set the code value to 53 (Bypass MC Trip). The inverter receives output signal from the OL detector and Bypass MC Trip occurs when motor overheat occurs during the bypass operation.								
IN-66-71 Px define	Switching to the bypass operation via the multifunction input signal is available when the code value is set to 18 (Exchange).								
OUT-33 Relay3	Operating VFD output contactor via the multifunction output is available when the code value is set to 17 (Inverter Line).								
OUT-34 Relay4	Operating motor OL lamp via the multifunction output is available when the code value is set to 41 (Bypass MC TRIP).								
OUT-35 Relay5	Operating bypass contactor via the multifunction output is available when the code value is set to 18 (Comm Line).								

## 3.3 Examples of Set-Up for Advanced Operation

These are examples of commonly used bypass functions. Refer to the following to configure parameter settings regarding the bypass.

### 3.3.1 Basic Bypass Operation

- Bypass operation when terminal signals and keypad parameters are input

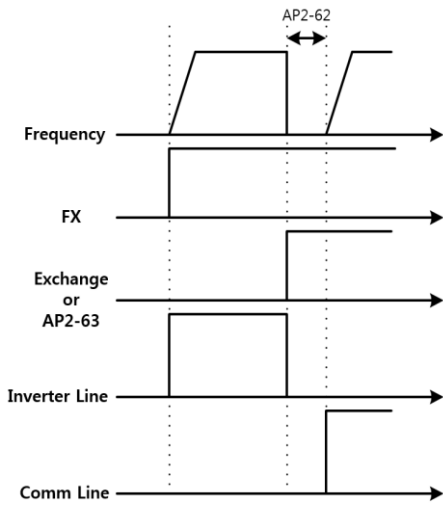

Parameter		
Code	Name	Parameter Setting
CNF-42	Multi-keyssel	None
OUT-33	Relay 3	Inverter Line
OUT-34	Relay 4	Bypass MC TRIP
OUT-35	Relay 5	Comm Line
IN-65	P1 Define	Bypass MC Trip
IN-66	P2 Define	Exchange
AP2-61	BPBackInlineT	5 sec
AP2-62	BY-Pass MC del	0.5 sec
AP2-63	Bypass	No
AP2-64	FLT AT Bypass	No
AP2-65	Select FLT	0000
AP2-66	INV Op ByPass	Yes

- Bypass operation when using the Multi key on the keypad

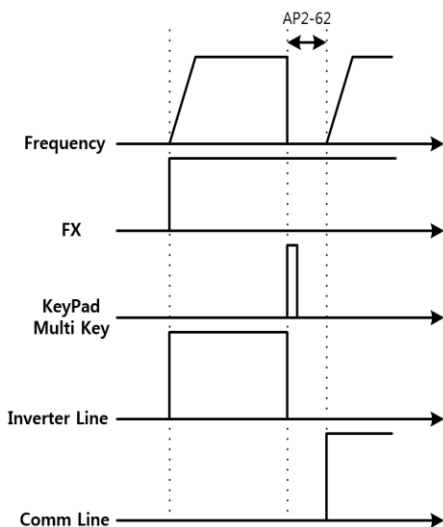

Parameter		
Code	Name	Parameter Setting
CNF-42	Multi-keyssel	Bypass
OUT-33	Relay 3	Inverter Line
OUT-34	Relay 4	Bypass MC TRIP
OUT-35	Relay 5	Comm Line
IN-65	P1 Define	Bypass MC Trip
IN-66	P2 Define	Exchange
AP2-61	BPBackInlineT	5 sec
AP2-62	BY-Pass MC del	0.5 sec
AP2-63	Bypass	No
AP2-64	FLT AT Bypass	No
AP2-65	Select FLT	0000
AP2-66	INV Op ByPass	Yes

■ Bypass operation when a trip occurs

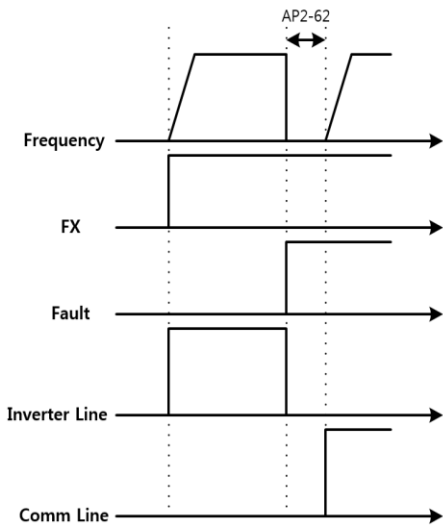

Parameter		
Code	Name	Parameter Setting
CNF-42	Multi-keyesl	Bypass
OUT-33	Relay 3	Inverter Line
OUT-34	Relay 4	Bypass MC TRIP
OUT-35	Relay 5	Comm Line
IN-65	P1 Define	Bypass MC Trip
IN-66	P2 Define	Exchange
AP2-61	BPBackInLineT	5 sec
AP2-62	BY-Pass MC del	0.5 sec
AP2-63	Bypass	No
AP2-64	FLT AT Bypass	Yes
AP2-65	Select FLT	1111
AP2-66	INV Op ByPass	Yes

### 3.3.2 Advanced Bypass Operation

- Bypass operation when INV Op ByPass (AP2-66) is set to No

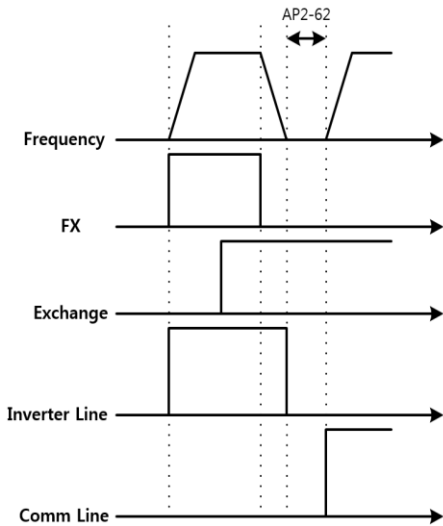

Parameter		
Code	Name	Parameter Setting
CNF-42	Multi-keyssel	None
OUT-33	Relay 3	Inverter Line
OUT-34	Relay 4	Bypass MC TRIP
OUT-35	Relay 5	Comm Line
IN-65	P1 Define	Bypass MC Trip
IN-66	P2 Define	Exchange
AP2-61	BPBackInlineT	5 sec
AP2-62	BY-Pass MC del	0.5 sec
AP2-63	Bypass	No
AP2-64	FLT AT Bypass	No
AP2-65	Select FLT	0000
AP2-66	INV Op ByPass	No

- Bypass operation is not started even the bypass command is received during inverter operation.
- Bypass operation is started after the inverter command is OFF (regular stop by the stop method) if the bypass command by the terminal block is received during inverter operation.

- Operation when switching from bypass operation to inverter operation

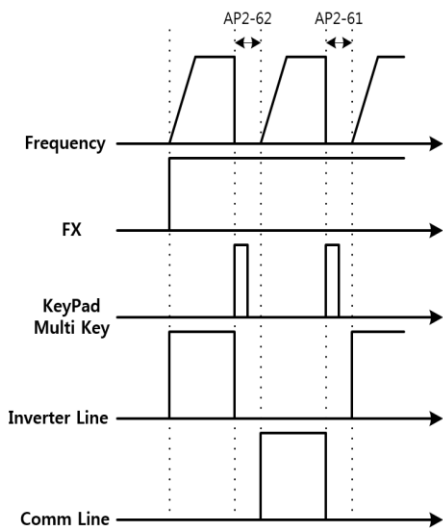

Parameter		
Code	Name	Parameter Setting
CNF-42	Multi-keyssel	None
OUT-33	Relay 3	Inverter Line
OUT-34	Relay 4	Bypass MC TRIP
OUT-35	Relay 5	Comm Line
IN-65	P1 Define	Bypass MC Trip
IN-66	P2 Define	Exchange
AP2-61	BPBackInlineT	5 sec
AP2-62	BY-Pass MC del	0.5 sec
AP2-63	Bypass	No
AP2-64	FLT AT Bypass	No
AP2-65	Select FLT	0000
AP2-66	INV Op ByPass	Yes

- The previous operation status is maintained when returning from bypass operation to inverter operation.

■ Operation when FLT AT ByPass (AP2-64) is Yes and Select FLT (AP2-65) is set

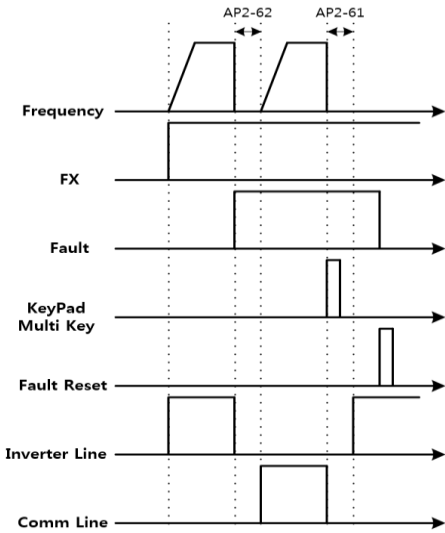

Parameter		
Code	Name	Parameter Setting
CNF-42	Multi-keyset	Bypass
OUT-33	Relay 3	Inverter Line
OUT-34	Relay 4	Bypass MC TRIP
OUT-35	Relay 5	Comm Line
IN-65	P1 Define	Bypass MC Trip
IN-66	P2 Define	Exchange
AP2-61	BPBackInLineT	5 sec
AP2-62	BY-Pass MC del	0.5 sec
AP2-63	Bypass	No
AP2-64	FLT AT Bypass	Yes
AP2-65	Select FLT	1111
AP2-66	INV Op ByPass	Yes

- The inverter automatically switches to the bypass operation when a fault set in AP2-65 occurs during inverter operation.
- To switch from bypass operation state by the fault trip to inverter mode,
  - ① press the Multi key on the keypad,
  - ② set parameter AP2-63 to NO,
  - ③ and then set bypass terminal block command.
- User must clear the fault because the fault status remains even after returning to the inverter mode.
- After resetting the inverter fault, operation command must be given to re-operate the inverter.

## 4 Fault Trips

When the SP100 detects a fault, it stops the operation (trips) or sends out a warning signal. When a trip or warning occurs, the keypad displays the information briefly. Detailed information is shown on the LCD display. Users can read the warning message at PRT-90. When more than 2 trips occur at roughly the same time, the keypad displays the higher priority fault information. In the keypad, fault trips with higher priority are displayed first. Use the [Up], [Down], [Left] or [Right] cursor key on the keypad to view the fault trip information. The fault conditions can be categorized as follows

- Level: When the fault is corrected, the trip or warning signal disappears and the fault is not saved in the fault history.
- Latch: When the fault is corrected and a reset input signal is provided, the trip or warning signal disappears.
- Fatal: When the fault is corrected, the fault trip or warning signal disappears only after the user turns off the SP100, waits until the charge indicator light goes off, and turns the inverter on again. If the the SP100 is still in a fault condition after powering it on again, please contact the supplier or the LS ELECTRIC customer service center.

### 4.1 Trip Items during the Bypass Operation

LCD Display	Category	Description
Bypass MC Trip	Latch	The motor overheat prevention function in bypass operation. Receives OL detector output signal from the inverter and outputs messages. * OL level can be configured by users in OL detector.

#### ⚠ Caution

- To reset Bypass MC Trip, press the reset button on the keypad. When the Power Switch is off, GMP Trip automatically terminated. (After turning off the Power Switch, please reboot by turning on the Power Switch).

## 4.2 Trip Items That Can Automatically Switch to the Bypass Operation during the Inverter Operation

LCD Display	Category	Description
Lost Command	Level	This trip occurs if frequency reference error or operation reference error is detected when inputting the references using other than the keypad, such as terminal block or communication. This is available when PRT-12 code is set to other than "0".
Over Voltage	Latch	This trip occurs if voltage of DC circuit exceeds the specified value.
Over Current1	Latch	This trip occurs if output current of the inverter exceeds 180% of rated current.
Over Current2	Latch	This trip occurs if inverter's internal DC section detects short circuit current.

\* The Bit in AP2-65 (Select FLT) must be set to use automatic bypass operation when above four trips occur.

\* For more trip items, refer to the H100 manual.

# 5 Technical Specification

## 3-Phase 200V (5.5–18.5kW)

Model □□□□SP100–2□□□		0055	0075	0110	0150	0185
Applied Motor	HP	7.5	10	15	20	25
	kW	5.5	7.5	11	15	18.5
Rated Output	Rated Capacity (kVA)	8.4	11.4	16.0	21.3	26.3
	Rated Current (A)	22	30	42	56	69
	Output Frequency	0 - 400 Hz				
	Output Voltage	3-Phase 240V (-10% - +10%)				
Rated Input	Working Voltage	3-Phase 240V (-10% - +10%)				
	Input Frequency	60 Hz (±5%)				
	Rated Current (A)	23.7	32.7	46.4	62.3	77.2

- The standard motor capacity is based on a standard 4-pole motor.
- The standard used for 200 V inverters is based on a 240 V supply voltage, and 400 V inverters are based on a 480 V supply voltage.  
Using outside of the range of inverter input voltage can lead to malfunction of SP100 and the transformer. It must be used within the input voltage range which is 480V/240V (-10% - +10%).
- The rated output current is limited based on the carrier frequency set at CON-04.

### 3-Phase 400V (5.5–18.5kW)

Model □□□□SP100-4□□□		0055	0075	0110	0150	0185
Applied Motor	HP	7.5	10	15	20	25
	kW	5.5	7.5	11	15	18.5
Rated Output	Rated Capacity (kVA)	9.1	12.2	18.3	23.0	29.0
	Rated Current (A)	12	16	24	30	38
	Output Frequency	0 - 400 Hz				
	Output Voltage	3-Phase 480V (-10% - +10%)				
Rated Input	Working Voltage	3-Phase 480V (-10% - +10%)				
	Input Frequency	60 Hz (±5%)				
	Rated Current (A)	12.2	17.5	26.5	33.4	42.5

- The standard motor capacity is based on a standard 4-pole motor.
- The standard used for 200 V inverters is based on a 240 V supply voltage, and 400 V inverters are based on a 480 V supply voltage.
- Using outside of the range of inverter input voltage can lead to malfunction of SP100 and the transformer. It must be used within the input voltage range which is 480V/240V (-10% - +10%).
- The rated output current is limited based on the carrier frequency set at CON-04.

### 3-Phase 400V (22–55kW)

Model □□□□SP100-4□□□		0220	0300	0370	0450	0550
Applied Motor	HP	30	40	50	60	75
	kW	22	30	37	45	55
Rated Output	Rated Capacity (kVA)	34.3	46.5	57.1	69.4	82.0
	Rated Current (A)	45	61	75	91	107
	Output Frequency	0 - 400 Hz				
	Output Voltage	3-Phase 480V (-10% - +10%)				
Rated Input	Working Voltage	3-Phase 480V (-10% - +10%)				
	Input Frequency	60 Hz (±5%)				
	Rated Current (A)	50.7	69.1	69.3	84.6	100.1

- The standard motor capacity is based on a standard 4-pole motor.
- The standard used for 200 V inverters is based on a 240 V supply voltage, and 400 V inverters are based on a 480 V supply voltage.
- Using outside of the range of inverter input voltage can lead to malfunction of SP100 and the transformer. It must be used within the input voltage range which is 480V/240V/ (-10% - +10%).
- The rated output current is limited based on the carrier frequency set at CON-04.

## 6 Product Warranty

### Warranty Information

Fill in this warranty information form and keep this page for future reference or when warranty service may be required.

<b>Product Name</b>	LS ELECTRIC Standard	<b>Date of Installation</b>	
<b>Model Name</b>	LSLV-SP100	<b>Warranty Period</b>	
<b>Customer Info</b>	Name (or company)		
	Address		
	Contact Info.		
<b>Retailer Info</b>	Name		
	Address		
	Contact info.		

### Warranty Period

The product warranty covers product malfunctions, under normal operating conditions, for 12 months from the date of installation. If the date of installation is unknown, the product warranty is valid for 18 months from the date of manufacturing. Please note that the product warranty terms may vary depending on purchase or installation contracts.

### Warranty Service Information

During the product warranty period, warranty service (free of charge) is provided for product malfunctions caused under normal operating conditions. For warranty service, contact an official LS ELECTRIC agent or service center.

### **Non-Warranty Service**

A service fee will be incurred for malfunctions in the following cases:

- intentional abuse or negligence
- power supply problems or from other appliances being connected to the product
- acts of nature (fire, flood, earthquake, gas accidents, etc.)
- modifications or repair by unauthorized persons
- missing authentic LS ELECTRIC rating plates
- expired warranty period

### **Visit Our Website**

Visit us at <http://www.lselectric.co.kr> for detailed service information.

### **Disclaimer of Liability**

Since the information regarding hardware and software in this publication is subject to change without notice, we neither warrant nor assume any legal liability or responsibility for full consistency. However, LS ELECTRIC constantly endeavors to review the contents of this publication regularly and to include any necessary corrections in subsequent editions