

The right choice for the ultimate yield!

LS ELECTRIC strives to maximize your profits in gratitude for choosing us as your partner.

Programmable Logic Control

High Speed Counter Module

XGB Series

User Manual

XBF-HO02A

XBF-HD02A



Safety Instructions

- Read this manual carefully before installing, wiring, operating, servicing or inspecting this equipment.
- Keep this manual within easy reach for quick reference.

LSELECTRIC

Before using the product ...

For your safety and effective operation, please read the safety instructions thoroughly before using the product.

- ▶ Safety Instructions should always be observed in order to prevent accident or risk with the safe and proper use the product.
- ▶ Instructions are divided into “Warning” and “Caution”, and the meaning of the terms is as follows.

 **Warning** This symbol indicates the possibility of serious injury or death if some applicable instruction is violated

 **Caution** This symbol indicates the possibility of severe or slight injury, and property damages if some applicable instruction is violated

Moreover, even classified events under its caution category may develop into serious accidents relying on situations. Therefore we strongly advise users to observe all precautions properly just like warnings.

- ▶ The marks displayed on the product and in the user’s manual have the following meanings.

 Be careful! Danger may be expected.

 Be careful! Electric shock may occur.

- ▶ The user’s manual even after read shall be kept available and accessible to any user of the product.

Safety Instructions for design process

Warning

- ▶ **Please install a protection circuit on the exterior of PLC so that the whole system may operate safely regardless of failures from external power or PLC.** Any abnormal output or operation from PLC may cause serious problems to safety in whole system.
 - Install protection units on the exterior of PLC like an interlock circuit that deals with opposite operations such as emergency stop, protection circuit, and forward/reverse rotation or install an interlock circuit that deals with high/low limit under its position controls.
 - If any system error (watch-dog timer error, module installation error, etc.) is detected during CPU operation in PLC, all output signals are designed to be turned off and stopped for safety. However, there are cases when output signals remain active due to device failures in Relay and TR which can't be detected. Thus, you are recommended to install an addition circuit to monitor the output status for those critical outputs which may cause significant problems.
- ▶ **Never overload more than rated current of output module nor allow to have a short circuit.** Over current for a long period time may cause a fire .
- ▶ **Never let the external power of the output circuit to be on earlier than PLC power**, which may cause accidents from abnormal output operation.
- ▶ **Please install interlock circuits in the sequence program for safe operations in the system when exchange data with PLC or modify operation modes using a computer or other external equipments** Read specific instructions thoroughly when conducting control operations with PLC.

Safety Instructions for design process

Caution

- ▶ **I/O signal or communication line shall be wired at least 100mm away from a high-voltage cable or power line.** Fail to follow this

Safety Instructions on installation process

Caution

- ▶ **Use PLC only in the environment specified in PLC manual or general standard of data sheet.** If not, electric shock, fire, abnormal operation of the product may be caused.
- ▶ **Before install or remove the module, be sure PLC power is off.** If not, electric shock or damage on the product may be caused.
- ▶ **Be sure that every module is securely attached after adding a module or an extension connector.** If the product is installed loosely or incorrectly, abnormal operation, error or dropping may be caused. In addition, contact failures under poor cable installation will be causing malfunctions as well.
- ▶ **Be sure that screws get tighten securely under vibrating environments.** Fail to do so will put the product under direct vibrations which will cause electric shock, fire and abnormal operation.
- ▶ **Do not come in contact with conducting parts in each module,** which may cause electric shock, malfunctions or abnormal operation.

Safety Instructions for wiring process

Warning

- ▶ **Prior to wiring works, make sure that every power is turned off.** If not, electric shock or damage on the product may be caused.
- ▶ **After wiring process is done, make sure that terminal covers are installed properly before its use.** Fail to install the cover may cause electric shocks.

Caution

- ▶ **Check rated voltages and terminal arrangements in each product prior to its wiring process.** Applying incorrect voltages other than rated voltages and misarrangement among terminals may cause fire or malfunctions.
- ▶ **Secure terminal screws tightly applying with specified torque.** If the screws get loose, short circuit, fire or abnormal operation may be caused. Securing screws too tightly will cause damages to the module or malfunctions, short circuit, and dropping.
- ▶ **Be sure to earth to the ground using Class 3 wires for FG terminals which is exclusively used for PLC.** If the terminals not grounded correctly, abnormal operation or electric shock may be caused.
- ▶ **Don't let any foreign materials such as wiring waste inside the module while wiring,** which may cause fire, damage on the product or abnormal operation.
- ▶ **Make sure that pressed terminals get tighten following the specified torque. External connector type shall be pressed or soldered using proper equipments.**

Safety Instructions for test-operation and maintenance

Warning

- ▶ **Don't touch the terminal when powered.** Electric shock or abnormal operation may occur.
- ▶ **Prior to cleaning or tightening the terminal screws, let all the external power off including PLC power.** If not, electric shock or abnormal operation may occur.
- ▶ **Don't let the battery recharged, disassembled, heated, short or soldered.** Heat, explosion or ignition may cause injuries or fire.

Caution

- ▶ **Do not make modifications or disassemble each module.** Fire, electric shock or abnormal operation may occur.
- ▶ **Prior to installing or disassembling the module, let all the external power off including PLC power.** If not, electric shock or abnormal operation may occur.
- ▶ **Keep any wireless equipment such as walkie-talkie or cell phones at least 30cm away from PLC.** If not, abnormal operation may be caused.
- ▶ **When making a modification on programs or using run to modify functions under PLC operations, read and comprehend all contents in the manual fully.** Mismanagement will cause damages to products and accidents.
- ▶ **Avoid any physical impact to the battery and prevent it from dropping as well.** Damages to battery may cause leakage from its fluid. When battery was dropped or exposed under strong impact, never reuse the battery again. Moreover skilled workers are needed when exchanging batteries.

Safety Instructions for waste disposal



Caution

- ▶ **Product or battery waste shall be processed as industrial waste.** The waste may discharge toxic materials or explode itself.

Revision History

Version	Date	Remark	Page
V 1.0	2012.05	First Edition	-
V 1.1	2015.07	1. Domain name changed 2. CI changed 3. General specifications changed by reason of changed IEC Specifications	- - 2-1
V 1.2	2016.03	1. Smart Link Connection Diagram added and changed	2-8~12
V1.3	2020.06	1. Changed company name to LS ELECTRIC	-
V1.4	2022.09	1. Changed domain to ls-electric.com	-

※ The number of User's manual is indicated right part of the back cover.

© LS ELECTRIC Co., Ltd 2012 All Rights Reserved.

About User's Manual

Congratulations on purchasing PLC of LS ELECTRIC Co.,Ltd.

Before use, make sure to carefully read and understand the User's Manual about the functions, performances, installation and programming of the product you purchased in order for correct use and importantly, let the end user and maintenance administrator to be provided with the User's Manual.

The User's Manual describes the product. If necessary, you may refer to the following description and order accordingly. In addition, you may connect our website (<http://www.ls-electric.com/>) and download the information as a PDF file.

Relevant User's Manuals

Title	Description	No. of User's Manual
XG5000 User's Manual (for XGK, XBC,XBM)	XG5000 software user manual describing online function such as programming, print, monitoring, debugging by using XGB(MK language) CPU	10310000511
XG5000 User's Manual (for XGI, XGR, XEC)	XG5000 software user manual describing online function such as programming, print, monitoring, debugging by using XGB(IEC language) CPU	10310000746
XGK/XGB Instructions & Programming User's Manual	User's manual for programming to explain how to use instructions that are used PLC system with XGK, XGB CPU.	10310000509
XGI/XGR/XEC Instructions & Programming User's Manual	User's manual for programming to explain how to use instructions that are used PLC system with XGI, XGR, XEC CPU.	10310000739
Ultimate Performance XGB Unit(MK/IEC)	It describes how to use XGB main unit, system configuration,mechanism,program function ,input/output function, Built-in High-speed Counter, Datalog, PID Control, Built-in Communication function, Built-in Position, Built-in Analog input/output..	10310000893, 10310001406
XGB hardware	It describes power, IO, extension specification and system configuration, built-in high speed counter of XGB main unit.	10310000893, 10310000981
XBC Standard / Economic Type Main Unit(MK/IEC)	It describes power, IO, extension specification and system configuration, built-in high speed counter of XGB standard / economic type main unit.	10310001090, 10310001273

© Table of Contents ©

Chapter 1 Overview	1-1
---------------------------------	------------

Chapter 2 Specifications	2-1 ~ 2-27
---------------------------------------	-------------------

2.1	GENERAL SPECIFICATIONS	2-1
2.2	PERFORMANCE SPECIFICATIONS	2-2
2.2.1	Performance specifications	2-2
2.2.2	Pulse input specification	2-3
2.2.3	Preset/Gate input specification	2-3
2.2.4	Comparison output specification	2-3
2.3	PART NAMES	2-4
2.3.1	Part Names	2-4
2.3.2	Specification of interface with external devices	2-6
2.4	FUNCTIONS	2-9
2.4.1	Pulse input mode	2-9
2.4.2	Counter mode	2-16
2.4.3	Preset	2-19
2.4.4	Compared output	2-20
2.4.5	Carry signal	2-24
2.4.6	Borrow signal	2-24
2.4.7	Auxiliary mode	2-25

Chapter 3 Installation and Wiring	3-1 ~ 3-7
--	------------------

3.1	INSTALLATION	3-1
3.1.1	Installation environment	3-1
3.1.2	Handling precautions	3-1
3.2	WIRING PRECAUTIONS	3-2
3.2.1	Example of DC5V voltage output wiring	3-3
3.2.2	Example of DC12V NPN Open Collector output wiring	3-4
3.2.3	Example of DC24V PNP Open Collector output wiring	3-6
3.2.4	Example of Line Driver output wiring	3-7

Chapter 4 Operation Procedures and Monitoring (XG5000)	4-1 ~ 4-12
---	-------------------

4.1	OPERATION METHOD	4-1
4.1.1	Execution of XG5000	4-1

4.2	PARAMETERS SETTING	4-4
4.2.1	Parameters setting screen	4-4
4.3	MONITORING AND TEST	4-6
4.3.1	Monitoring/Test screen	4-6
4.4	REGISTER U DEVICES.....	4-9
4.4.1	View variables	4-9
4.4.2	Register U Devices.....	4-9
4.5	REGISTRATION OF SPECIAL MODULE VARIABLE	4-12
4.5.1	Global/Direct Variables screen.....	4-12
4.5.2	Registration of the special module variables	4-12

Chapter 5 Internal Memory & I/O Signals	5-1 ~ 5-3
--	------------------

5.1	INTERNAL MEMORY	5-1
5.1.1	Configuration of the internal memory	5-1
5.1.2	Details & Data configuration.....	5-2
5.2	I/O SIGNALS.....	5-3

Chapter 6 Global Constant & Global Variable	6-1 ~ 6-4
--	------------------

6.1	GLOBAL CONSTANT	6-1
6.1.1	The configuration of Global Constant.....	6-1
6.1.2	The Configuration and Contents of Data	6-2
6.2	GLOBAL VARIABLE.....	6-4

Chapter 7 Programming	7-1 ~ 7-29
------------------------------------	-------------------

7.1	INSTRUCTION AND FUNCTION BLOCK	7-1
7.1.1	Instruction of XGK series.....	7-1
7.1.2	Function Block of XGI/XGR.....	7-4
7.2	PROGRAM.....	7-7
7.2.1	Count mode setting	7-7
7.2.2	Pulse input mode setting	7-10
7.2.3	Counter check	7-11
7.2.4	Preset value setting and enable preset.....	7-12
7.2.5	Enable counter	7-13
7.2.6	Carry/borrow detection reset	7-13
7.2.7	Auxiliary mode setting and Enable auxiliary function.....	7-14
7.2.8	Up/down count selection	7-20
7.2.9	Use of external preset signal.....	7-20
7.2.10	Use of external auxiliary function signal	7-21
7.2.11	Type of comparison and comparison value setting.....	7-22
7.2.12	Enable comparison, Enable comparison output, Comparison agreement reset.....	7-24
7.2.13	Comparison output status setting	7-25
7.2.14	Input pulse active level setting.....	7-26

7.2.15 Error status and error code 7-27
7.2.16 Hold count when power fails 7-28

Chapter 8 Troubleshooting 8-1 ~ 8-9

8.1 ERROR CODE 8-1
8.2 TROUBLESHOOTING 8-2
 8.2.1 LED display status of HS counter module 8-2
 8.2.2 Counter status of HS counter module 8-2
 8.2.3 Output status of HS counter module 8-2
8.3 TROUBLESHOOTING SEQUENCE 8-3
 8.3.1 RDY LED Off 8-3
 8.3.2 RDY LED Blinks 8-4
 8.3.3 Counter operation error 8-5
 8.3.4 Counter value error 8-6
 8.3.5 Output operation error 8-7
 8.3.6 Module status check through XG5000 system monitoring 8-8

Appendices Appendix -1 ~ Appendix -2

Appendix 1 Terminology Appendix 1
Appendix 2 Dimensions Appendix 2

Warranty and Environmental Policy

Chapter 1. Overview

XGB High Speed counter modules are designed for XGB(XBM/XBC/XEC) series and used with XGT PLC CPU. And XBF-HO02A(Open Collector type) , XBF-HD02A(Line Drive type) modules are available.

1.1 Characteristic

High Speed Counter modules can count the high speed pulses which can not be processed by CPU module's counter instructions (CTU, CTD, CTUD etc.), up to binary value of 32 bits (-2,147,483,648 ~ 2,147,483,647).

High Speed counter modules have the following functions.

- (1) XGB PLC is available.
- (2) Three kinds of pulse inputs function
 - (a) 1-phase input: Increasing/Decreasing function Program or by means of the B-phase input (1-multiplier, 2-multiplier)
 - (b) 2-phase is input: Increasing/Decreasing function by means of the difference in phase.(1-multiplier, 2-multiplier, 4-multiplier)
 - (c) CW/CCW is input: Increasing/Decreasing function by means of A-phase or B-phase.(1-multiplier)
- (3) Preset and Gate function by means of the applicable program or external input signal
- (4) 6 additional functions are available such as Count Clear, Count Latch, Sampling Count, Input frequency Measure, Revolution Measure per unit time and Count Disable.
- (5) 7 kinds of compared signals can be outputted at output contact of the built-in transistor through compared based value (Min compared value, Max compared value) and current count value.
- (6) Provided Low Active and High Active mode.
(Preset and Gate input is only available a high active mode.)
- (7) Currently user manual of HSC module is written based on the following version.

XGB Main Unit		Version
XBM	XBM-D□□□S	V3.20 or above
XBC	XBC-D□□□H	V2.10 or above
	XBC-D□□□S	V1.20 or above
	XBC-D□□□SU	V1.20 or above
	XBC-D□□□E	Unavailable
XEC	XEC-D□□□H	V1.40 or above
	XEC-D□□□S	V1.00 or above
PADT	XG5000	V3.64 or above

Chapter 2 Specifications

2.1 General Specifications

General specifications of XGT series

No.	Item	Specifications	Related specifications		
1	Ambient temperature	0°C ~ +55°C	-		
2	Storage temperature	-25°C ~ +70°C	-		
3	Ambient humidity	5 ~ 95%RH (Non-condensing)	-		
4	Storage humidity	5 ~ 95%RH (Non-condensing)	-		
5	Vibration resistance	Occasional vibration		-	
		Frequency	Acceleration	Amplitude	How many times
		5 ≤ f < 8.4 Hz	-	3.5 mm	
		8.4 ≤ f ≤ 150 Hz	9.8 m/s ² (1G)	-	10 times each directions (X, Y and Z)
		For continuous vibration			
		Frequency	Acceleration	Amplitude	
				5 ≤ f < 8.4 Hz	-
		8.4 ≤ f ≤ 150 Hz	4.9 m/s ² (0.5G)	-	
6	Shock resistance	<ul style="list-style-type: none"> Peak acceleration: 147 m/s²(15G) Duration: 11ms Half-sine, 3 times each direction per each axis 	IEC61131-2		
7	Noise resistance	Square wave Impulse noise	AC: ± 1,500V DC: ± 900V	LS ELECTRIC standard	
		Electrostatic discharge	Voltage : 4kV (contact discharging)	IEC 61131-2, IEC 61000-4-2	
		Radiated electromagnetic field noise	80 ~ 1,000 MHz, 10V/m	IEC 61131-2, IEC 61000-4-3	
		Fast transient /bust noise	Segment Power supply module Digital/analog input/output communication interface	IEC 61131-2, IEC 61000-4-4	
		Voltage 2kV 1kV			
8	Environment	Free from corrosive gasses and excessive dust	-		
9	Altitude	Up to 2,000 ms	-		
10	Pollution degree	Less than equal to 2	-		
11	Cooling	Air-cooling	-		

Notes

- 1) IEC(International Electrotechnical Commission):
An international nongovernmental organization which promotes internationally cooperated standardization in electric/electronic fields, publishes international standards and manages applicable estimation system related with.
- 2) Pollution degree:
An index indicating pollution level of the operating environment which decides insulation performance of the devices. For instance, Pollution level 2 indicates the state generally that only non-conductive pollution occurs. However, this state contains temporary conduction due to dew produced.

2.2 Performance Specifications

Specifications of High Speed counter module's basic performance, preset/gate input and transistor output are as described below.

2.2.1 Performance specifications

Item		Specification	
		XBF-HO02A	XGF-HD02A
Count Input signal	Signal	A-phase, B-phase	
	Input type	Voltage input (Open Collector)	Differential input (Line Drive):
	Signal level	DC 5/12/24V	RS-422A Line Drive/HTL LEVEL Line Drive
Maximum coefficient speed		200kpps	500kpps (HTL input : 250kpps)
Number of channels		2 Channels	
Coefficient range		Signed 32-bit (-2,147,483,648 ~ 2,147,483,647)	
Count mode		Linear Count (When 32-bit range exceeded, Carry/Borrow occurs, the count value stopped)	
		Ring Count (repeated count within setting range)	
Input pulse mode		1-phase input	
		2-phase input	
		CW/CCW input	
Up/down Setting	1-phase input	Increasing/decreasing operation setting by B-phase input	
	2-phase input	Automatic setting by difference in phase	
	CW/CCW	A-phase input: increasing operation B-phase input: decreasing operation	
Multiplication function	1-phase input	1/2 multiplication	
	2-phase input	1/2/4 multiplication	
	CW/CCW	1-multiplication	
Control input	Signal	Preset instruction input, auxiliary mode instruction input	
	Signal level	DC 5V/12V/24V (by terminal selection) input type	
	Signal type	Voltage	
External output	Output points	2-point/channel (for each channel): terminal output available	
	Type	Select single-compared (>, >=, =, =<, <) or section compared output (included or excluded)	
	Output type	Open collector output (Sink)	
Operation Status Display	Input Signal	A-phase input, B-phase input, Preset instruction input, auxiliary mode instruction input	
	Output Signal	External output 0, External output 1	
	Busy Status	Module Ready	
Count Enable		To be set through program (count available only in enable status)	
Preset function		To be set through terminal or program	
auxiliary mode function		Count clear, Count latch, Section count(time setting value: 0~60000ms), Measurement of input frequency(for respective input phase), Measurement of counts per hour(time setting value: 0~60000ms) Count prohibited function	
Terminal		40 pin connector	
I/O occupied points		Fixed point: 64	
Internal consumed current		200mA	260mA
Weight		90g	

2.2.2 Pulse input specification

Item	Specification			Line driver
	Open collector			
Input volatage	DC 24V (17.0V~26.4V)	DC 12V (9.8V~13.2V)	DC 5V (4.5V~5.5V)	RS-422A line driver (5V level)/HTL line Driver(24V level)
Input current	7mA~11mA	7mA~11mA	7mA~11mA	
Min. On guaranteed voltage	17.0V	9.8V	4.1V	
Max. Off guaranteed voltage	4.5V	3.0V	1.7V	

2.2.3 Preset, auxiliary function input specification

Item	Specification		
Input volatage	DC 24V (17.0V~26.4V)	DC 12V (9.8V~13.2V)	DC 5V (4.5V~5.5V)
Input current	7mA~11mA	7mA~11mA	7mA~11mA
Min. On guaranteed voltage	17.0V	9.8V	4.1V
Max. Off guaranteed voltage	4.5V	3.0V	1.7V
On delay time	1 ms or less		
Off delay time	1 ms or less		

2.2.4 Comp. output specification

Item	Specification
Output type	Transistor sink
Rated output	DC 24V, 100 mA/point
Leakage current	0.1 mA or less
Saturated area voltage	1.3 V or less
On delay time	0.1 ms or less
Off delay time	0.1 ms or less

2.3 Part Names

2.3.1 Part Names

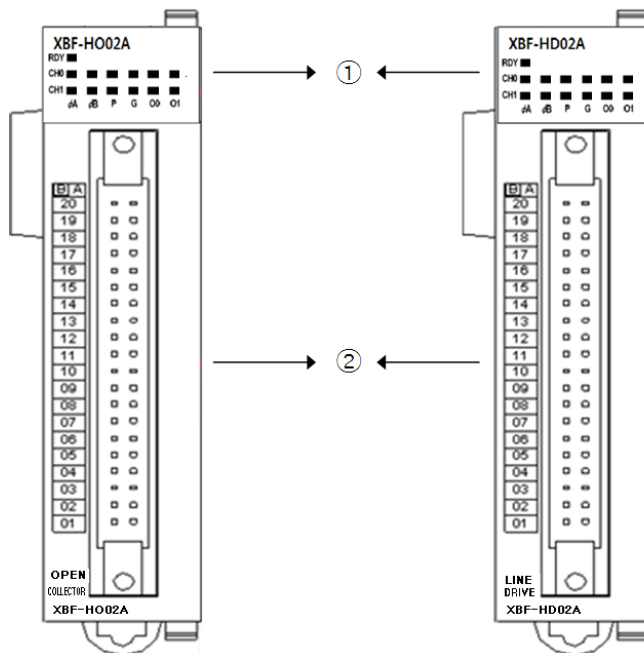

No.	Name	Contents
①	Run LED (ΦA, ΦB, P, G, O0, O1)	On: relevant channel pulse inputting, Preset/Auxiliary function signal inputting, Comparison outputting Off: No input of relevant channel pulse, No input of preset/auxiliary function signal, No output of comparison
	Ready signal (RDY)	On: HSC module normal Off: Power off or CPU module reset, HSC module error Flicker: HSC module error
②	External wiring connector	Connector to connect with external I/O

2.3.2 Specification of interface with external devices

1. Arrangement of connector pins

(1) XBF-HO02A

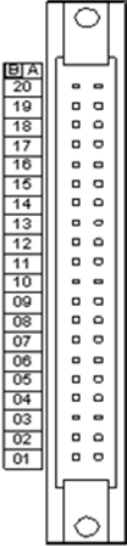
Pin arrangement	B	A	Signal name	
	CH1	CH0		
	20	20	A24V	A phase pulse input 24V
	19	19	A12V	A phase pulse input 12V
	18	18	A5V	A phase pulse input 5V
	17	17	ACOM	A phase pulse input COM
	16	16	B24V	B phase pulse input 24V
	15	15	B12V	B phase pulse input 12V
	14	14	B5V	B phase pulse input 5V
	13	13	BCOM	B phase pulse input COM
	12	12	P24V	Preset input 24V
	11	11	P12V	Preset input 12V
	10	10	P5V	Preset input 5V
	09	09	PCOM	Preset input COM
	08	08	G24V	Auxiliary function input 24V
	07	07	G12V	Auxiliary function input 12V
	06	06	G5V	Auxiliary function input 5V
	05	05	GCOM	Auxiliary function input COM
	04	04	OUT0	Comp. output 0
	03	03	OUT1	Comp. output 1
	02	02	24V	External power input 24V
	01	01	24G	External power input GND

(2) XBF-HD02A

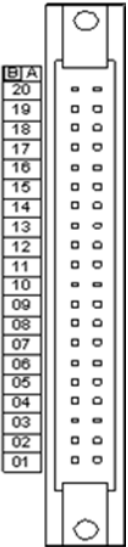
Pin arrangement	B	A	Signal name	
	CH1	CH0		
	20	20	A I +	A I phase differentiation input +
	19	19	A I -	A I phase differentiation input -
	18	18	A II +	A II phase differentiation input +
	17	17	A II -	A II phase differentiation input -
	16	16	B I +	B I phase differentiation input +
	15	15	B I -	B I phase differentiation input -
	14	14	B II +	B II phase differentiation input +
	13	13	B II -	B II phase differentiation input -
	12	12	P24V	Preset input 24V
	11	11	P12V	Preset input 12V
	10	10	P5V	Preset input 5V
	09	09	PCOM	Preset input COM
	08	08	G24V	Auxiliary function input 24V
	07	07	G12V	Auxiliary function input 12V
	06	06	G5V	Auxiliary function input 5V
	05	05	GCOM	Auxiliary function input COM
	04	04	OUT0	Comp. output 0
	03	03	OUT1	Comp. output 1
	02	02	24V	External power input 24V
	01	01	24G	External power input GND

2. Internal circuit

Describes internal circuit of HSC module to connect HSC module with external device

(1) XBF-HO02A

I/O	Internal circuit	No.	Terminal	Pin No.		Signal name
				CH0	CH1	
Input		①	A24V	B20	A20	A phase pulse input 24V
		②	A12V	B19	A19	A phase pulse input 12V
		③	A5V	B18	A18	A phase pulse input 5V
		④	ACOM	B17	A17	A phase pulse input COM
		①	B24V	B16	A16	B phase pulse input 24V
		②	B12V	B15	A15	B phase pulse input 12V
		③	B5V	B14	A14	B phase pulse input 5V
		④	BCOM	B13	A13	B phase pulse input COM
		⑤	P24V	B12	A12	Preset input 24V
		⑥	P12V	B11	A11	Preset input 12V
		⑦	P5V	B10	A10	Preset input 5V
		⑧	PCOM	B09	A09	Preset input COM
		⑤	G24V	B08	A08	Auxiliary function input 24V
		⑥	G12V	B07	A07	Auxiliary function input 12V
		⑦	G5V	B06	A06	Auxiliary function input 5V
		⑧	GCOM	B05	A05	Auxiliary function input COM
Output		⑨	OUT0	B04	A04	Comp. output 0
		⑩	OUT1	B03	A03	Comp. output 1
		⑪	24V	B02	A02	External power input 24V
		⑫	24G	B01	A01	External power input GND

Notes

External power (24V: A02, B02, 24G: A01, B01) is power source to output comparison output to terminal (A03, B03, A04, B04). Connect when using comparison output.

(2) XBF-HD02A

I/O	Internal circuit	No.	Terminal	Pin. No.		Signal
				CH0	CH1	
Input		①	AI+	B20	A20	A I phase differentiation input +
		②	AII+	B19	A19	A II phase differentiation input +
		③	AI-	B18	A18	A I phase differentiation input -
		④	AII-	B17	A17	A II phase differentiation input -
		①	BI+	B16	A16	B I phase differentiation input +
		②	BII+	B15	A15	B II phase differentiation input +
		③	BI-	B14	A14	B I phase differentiation input -
		④	BII-	B13	A13	B II phase differentiation input -
		⑤	P24V	B12	A12	Preset input 24V
		⑥	P12V	B11	A11	Preset input 12V
		⑦	P5V	B10	A10	Preset input 5V
		⑧	PCOM	B09	A09	Preset input COM
		⑤	G24V	B08	A08	Auxiliary function input 24V
		⑥	G12V	B07	A07	Auxiliary function input 12V
		⑦	G5V	B06	A06	Auxiliary function input 5V
		⑧	GCOM	B05	A05	Auxiliary function input COM
Output		⑨	OUT0	B04	A04	Comp. output 0
		⑩	OUT1	B03	A03	Comp. output 1
		⑪	24V	B02	A02	External power input 24V
		⑫	24G	B01	A01	External power input GND

Notes

- (1) AI+, AI-, BI+, BI- are line driver input terminal of 5V level.
- (2) AII+, AII-, BII+, BII- are line driver input terminal of 24V level.

(3) Example Input/Output wiring by using Smart Link Board

- (a) When using HSC module, easy wiring is available by connecting the I/O connector with Smart Link Board. The available Smart Link Board and I/O cable are as follows.

Model	Specification	No. of Pin
XBF-H002A	HSC Module(Open collector)	40 Pin Connector x 1
XBF-HD02A	HSC Module(Line Drive)	40 Pin Connector x 1

- (b) The company prepares smart link products for the convenience of using our Connector type HSC modules. For further information, please refer to the data sheet contained in a Smart Link product. (Refer to (d) Connection Diagram to confirm the differences between TG7-1H40CA and TG7-1H40S)

	Model	Cable	Length of Cable
Terminal Board	TG7-1H40S	C40HH-05SB-XBI	0.5m
		C40HH-10SB-XBI	1m
		C40HH-15SB-XBI	1.5m
		C40HH-20SB-XBI	2m
		C40HH-30SB-XBI	3m
	TG7-1H40CA (20Pin Common Added)	C40HH-05SB-XBI	0.5m
		C40HH-10SB-XBI	1m
		C40HH-15SB-XBI	1.5m
		C40HH-20SB-XBI	2m
		C40HH-30SB-XBI	3m

(C) Smart Link Connection

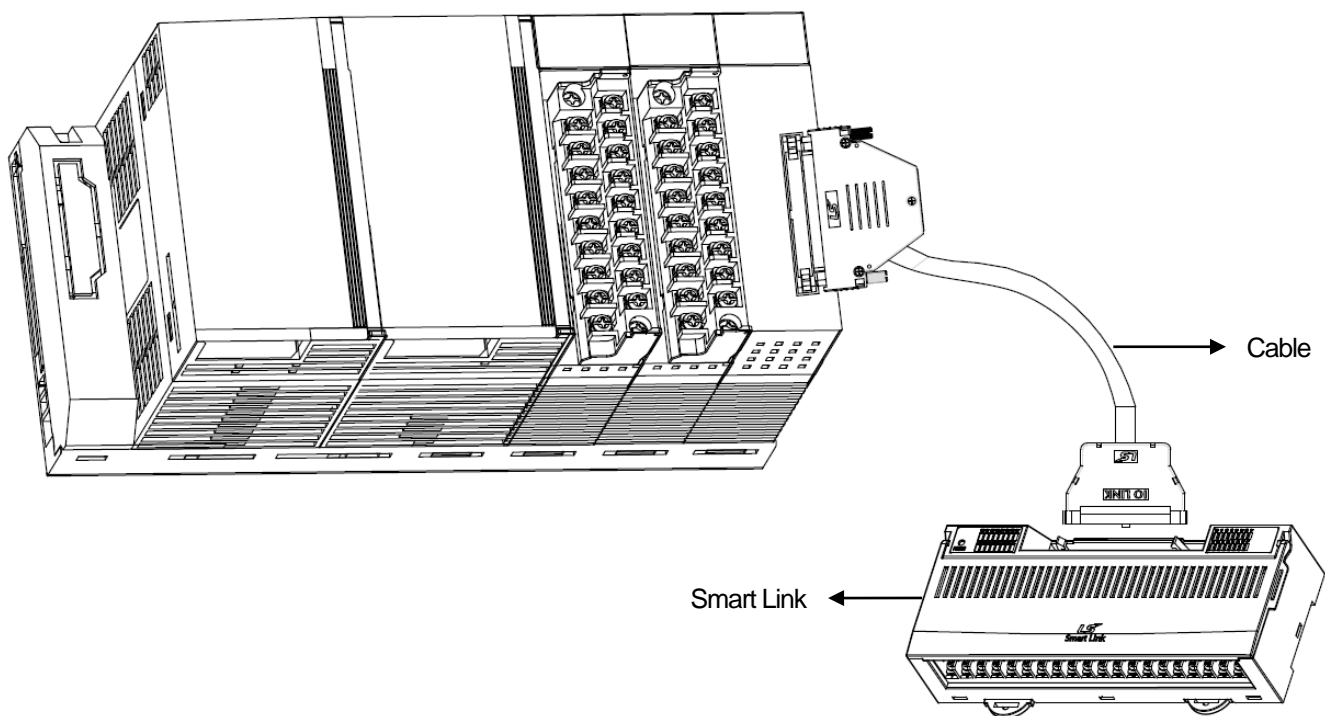

(d) Smart Link Connection Diagram

- TG7-1H40S

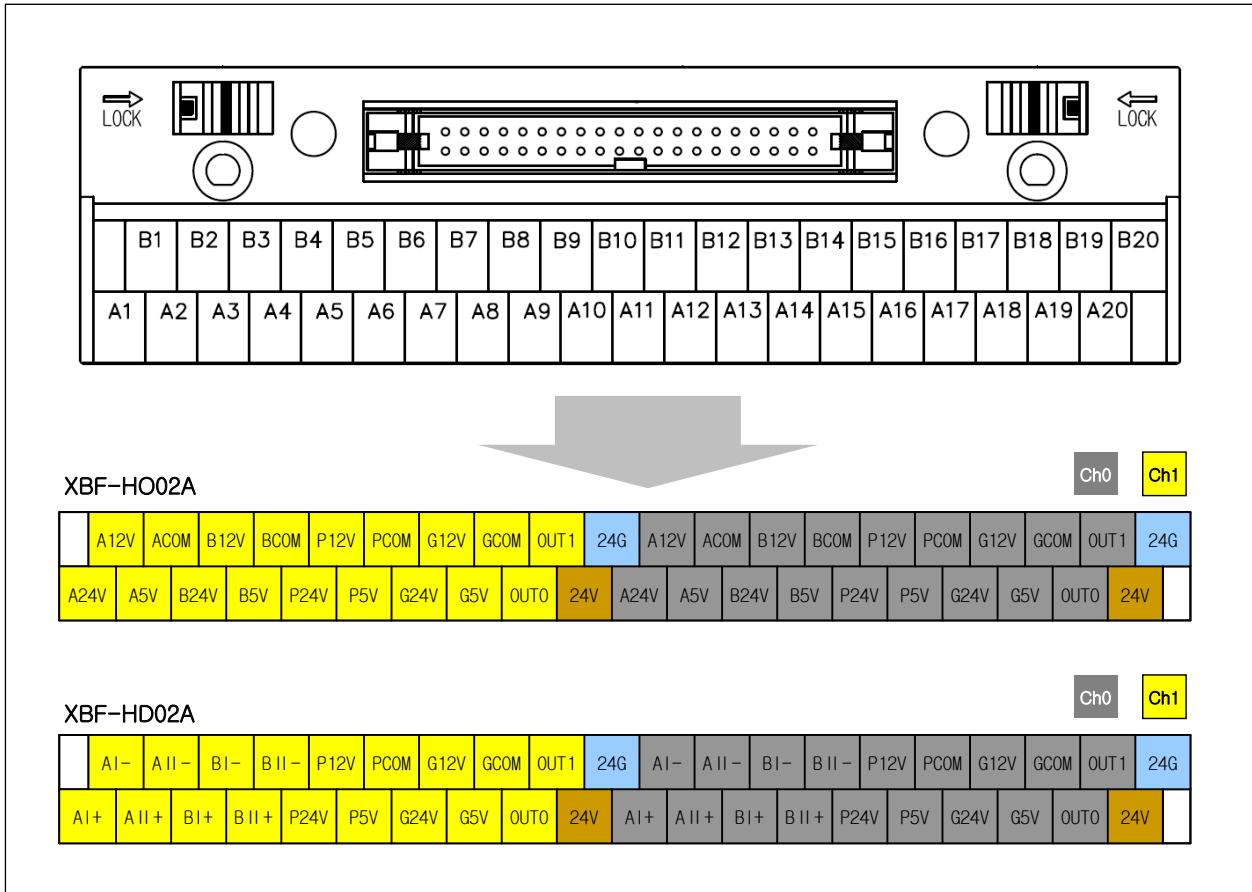

-TG7-1H40CA

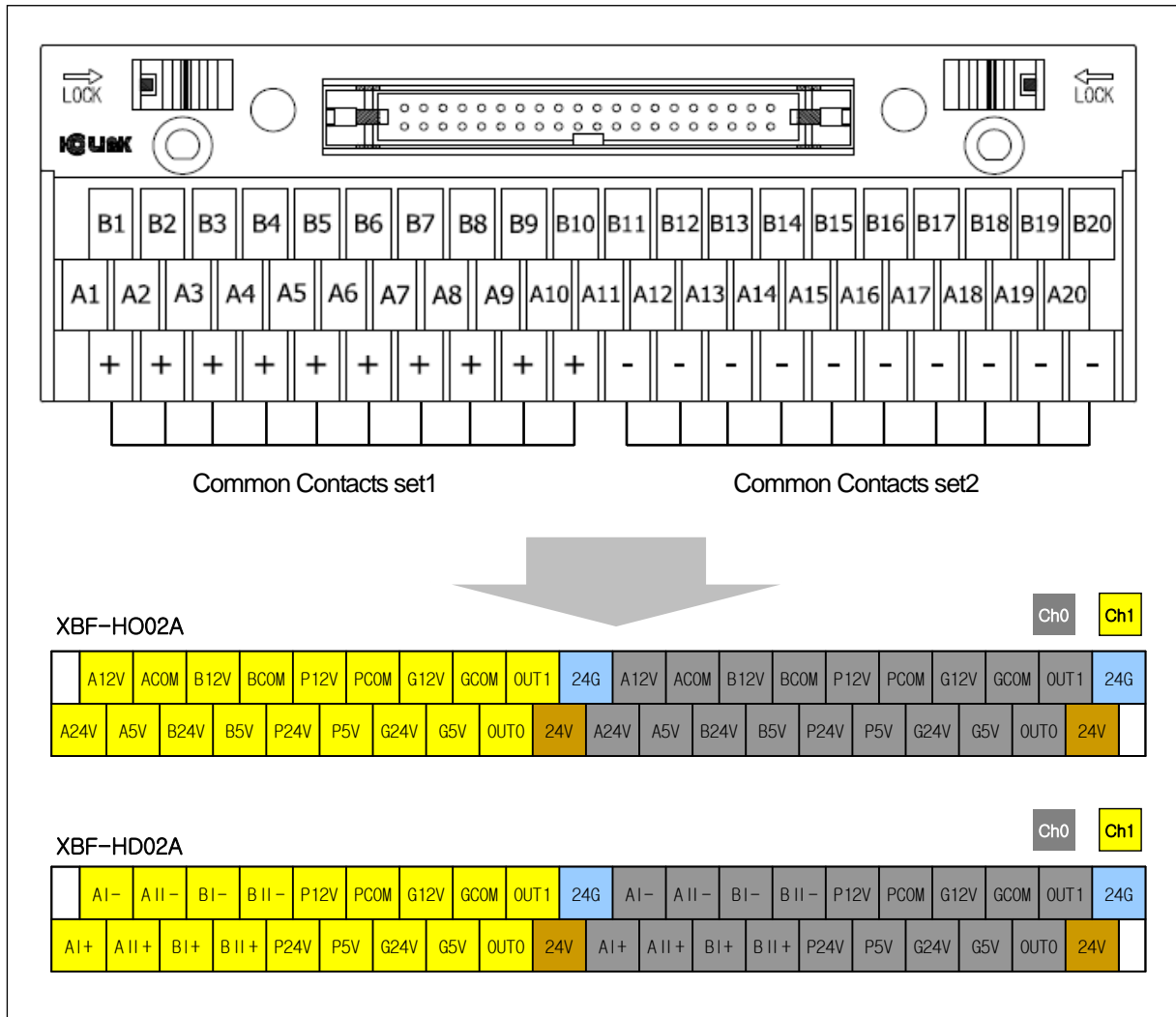

(e) Smart Link Specifications and Dimensions

- TG7-1H40S

i) Specifications

Rated Voltage	AC, DC 125V
Rated Current	1A
Withstanding Voltage	600V 1min
Insulation resistance	100MΩ (DC 500V)
Applicable Wire	1.25mm ² /MAX
T/B Screw	M3 X 10L
Screw Torque	1.2N • m(12Kgf • cm)
Case	Modified PPO(Noryl)(UL 94V-0)

ii) Dimensions(mm)

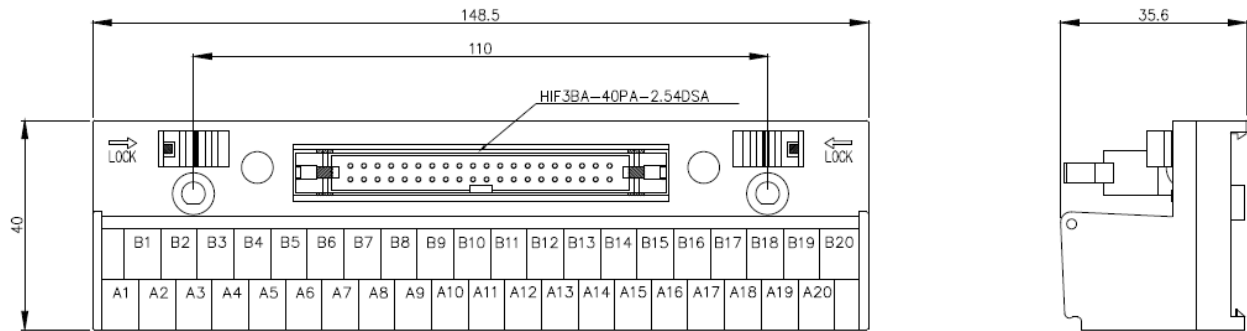

-TG7-1H40CA

i) Specifications

Rated Voltage		125V AC / 24V DC
Rated Current	IO	1A
	Common	10A (Total)
Insulation resistance		100MΩ (DC 500V)
Withstanding Voltage		AC500V 1min
Applicable Wire		AWG22-16 (MAX / 1.5mm ²)
Contact Screw		M3 X 10L
Screw Torque		1.2N • m(12Kgf • cm)
Ambient Temperature		-10℃ ~ +50℃ (Non-condensing)
Terminal Block & Cover		Modified PPO
Protective Cover		Polycarbonate
PCB		Epoxy 1.6t

ii) Dimensions(mm)

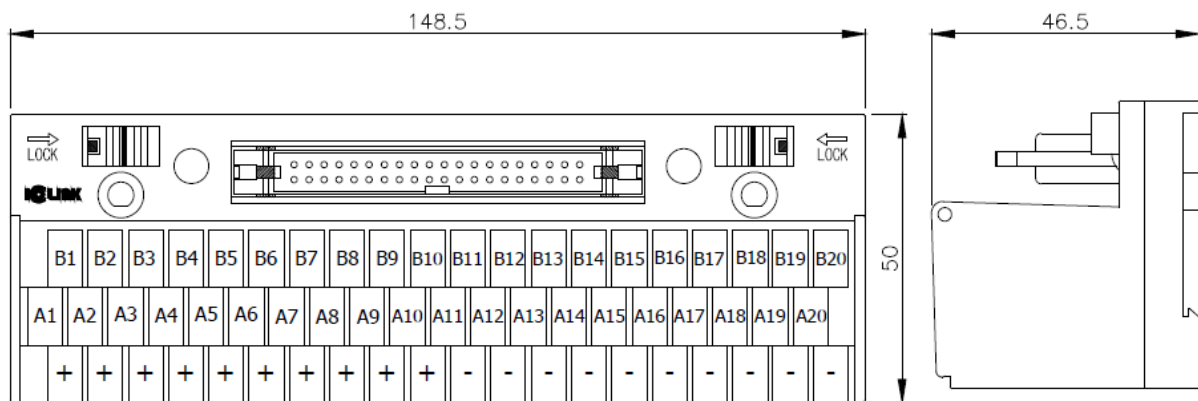

2.4 Function

2.4.1 Input pulse type

1. 1 phase input

(1) Up/Down operation by program setting

(a) 1 phase 1 input 1 multiplication input

When input pulse of A phase is rising, count operates and up/down count operation is set by program

1) High Active Mode

Up/Down count classification	A phase pulse rising	A phase pulse falling
Up/Down count setting Off	Up count (+1)	-
Up/Down count setting On	-	Down count (-1)

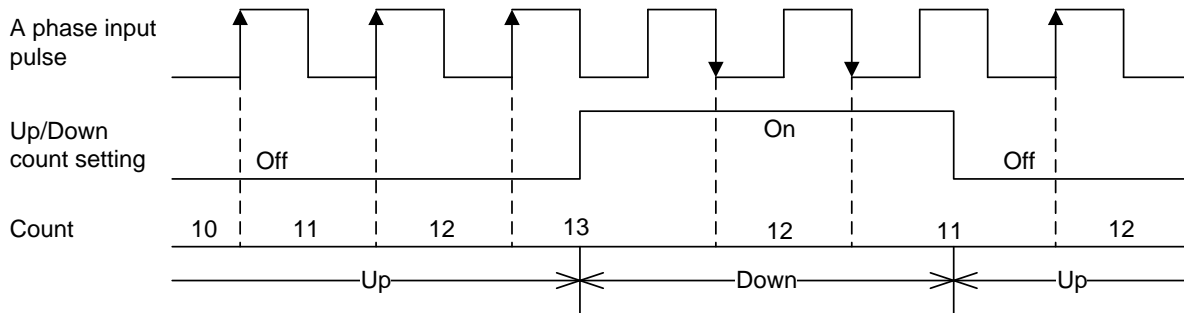

2) Low Active Mode

Up/Down count classification	A phase pulse rising	A phase pulse falling
Up/Down count setting Off	-	Up count (+1)
Up/Down count setting On	Down count (-1)	-

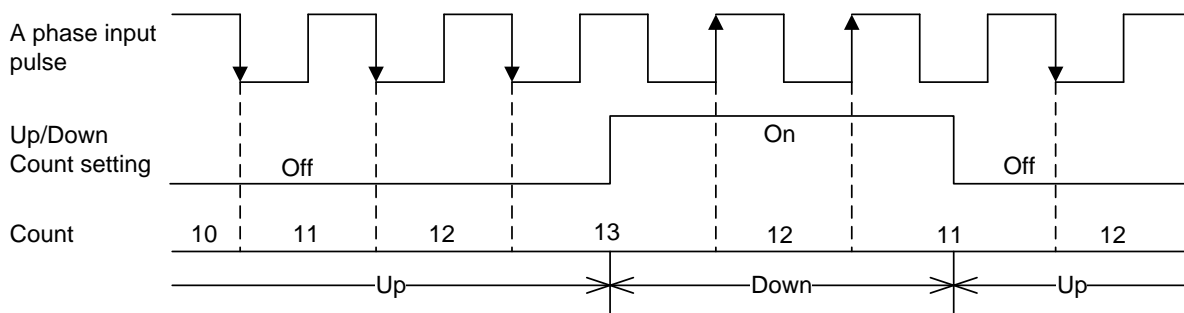

(b) 1 phase 1 input 2 multiplication input

When input pulse of A phase is rising and falling, count operates and up/down count operation is set by program

Up/Down count classification	A phase pulse rising	A phase pulse falling
Up/Down count setting Off	Up count (+1)	Up count (+1)
Up/Down count setting On	Down count (-1)	Down count (-1)

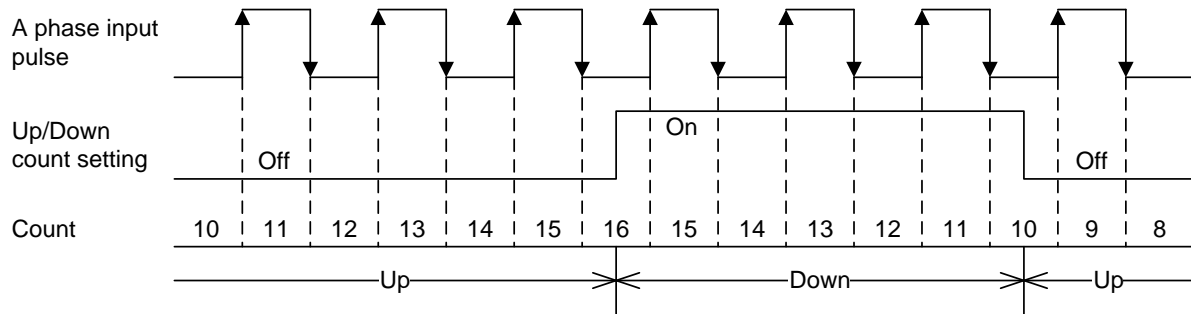

(2) Up/Down count operation by B phase input signal

(a) 1 phase 2 input 1 multiplication input

When input pulse of A phase is rising, count operates and up/down count operation is set by level of B phase input pulse.

1) High Active Mode

Up/Down count classification	A phase pulse rising	A phase pulse falling
B phase input pulse Off	Up count (+1)	-
B phase input pulse On	-	Down count (-1)

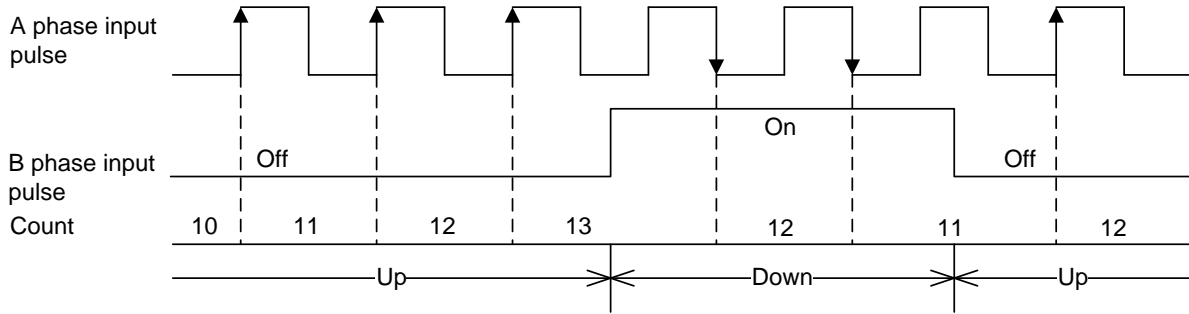

2) Low Active Mode

Up/Down count classification	A phase pulse rising	A phase pulse falling
B phase input pulse Off	Down count (-1)	-
B phase input pulse On	-	Up count (+1)

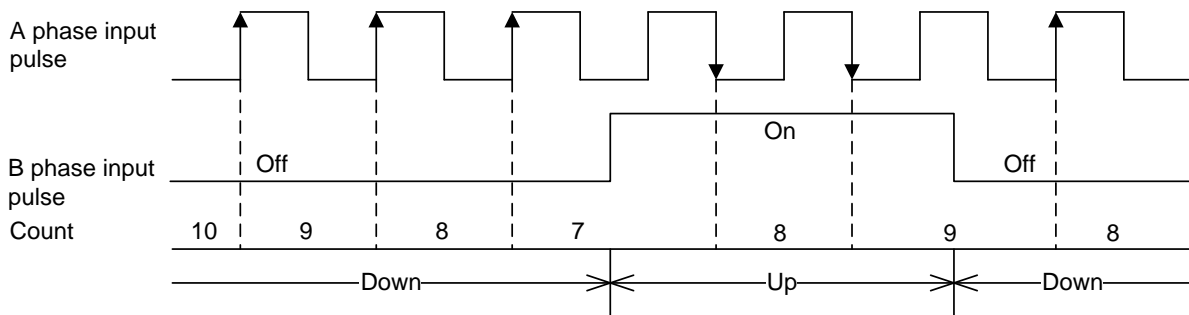

(b) 1 phase 2 input 2 multiplication input

When input pulse of A phase is rising and falling, count operates and up/down count operation is set by level of B phase input pulse.

1) High Active Mode

Up/Down count classification	A phase pulse rising	A phase pulse falling
B phase input pulse Off	Up count (+1)	Up count (+1)
B phase input pulse On	Down count (-1)	Down count (-1)

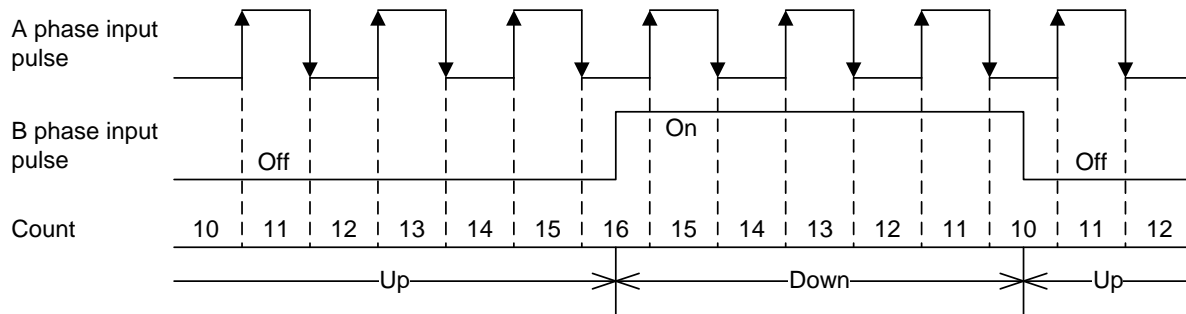

2) Low Active Mode

Up/Down count classification	A phase pulse rising	A phase pulse falling
B phase input pulse Off	Down count (-1)	Down count (-1)
B phase input pulse On	Up count (+1)	Up count (+1)

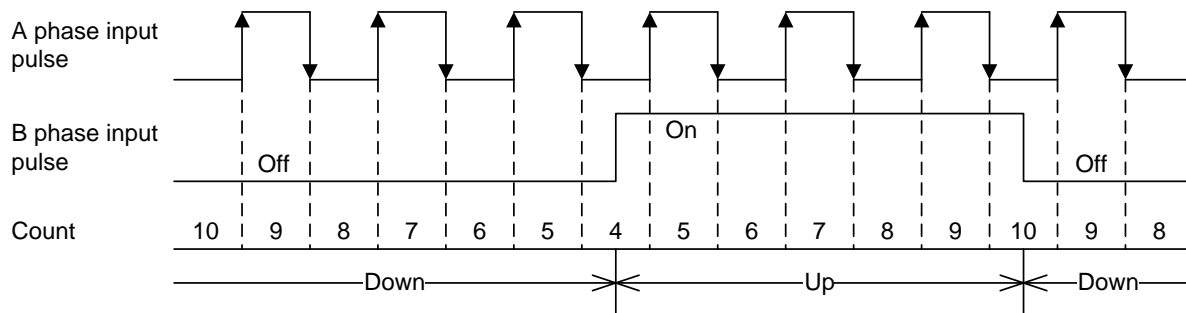

2. 2 phase input

(1) 2 phase 1 multiplication input

1) High Active Mode

When input pulse of A phase is ahead of B phase input pulse, at rising edge of A phase input pulse, Up count is operated.

When input pulse of B phase is ahead of A phase input pulse, at falling edge of A phase input pulse, Down count is operated.

Up/Down count classification	A phase pulse rising	A phase pulse falling
Phase of A and B (A-B)	Up count (+1)	-
Phase of A and B (B-A)	-	Down count (-1)

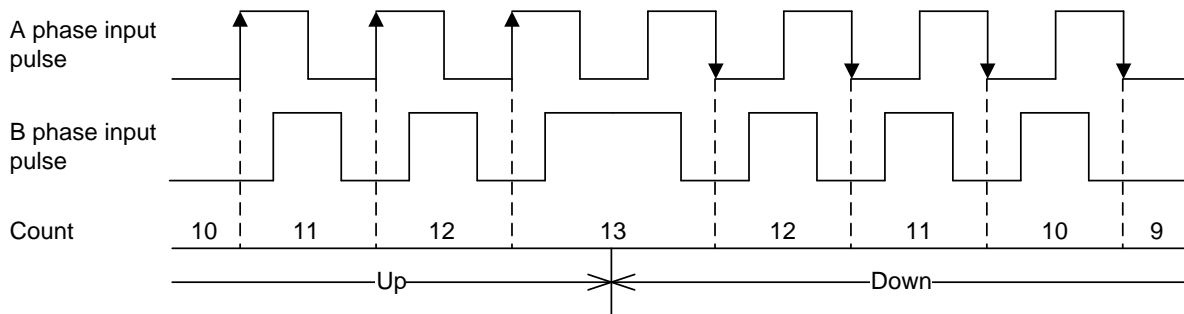

2) Low Active Mode

When input pulse of A phase is ahead of B phase input pulse, at falling edge of A phase input pulse, Up count is operated.

When input pulse of B phase is ahead of A phase input pulse, at rising edge of A phase input pulse, Down count is operated.

Up/Down count classification	A phase pulse rising	A phase pulse falling
Phase of A and B (A-B)	-	Up count (+1)
Phase of A and B (B-A)	Down count (-1)	-

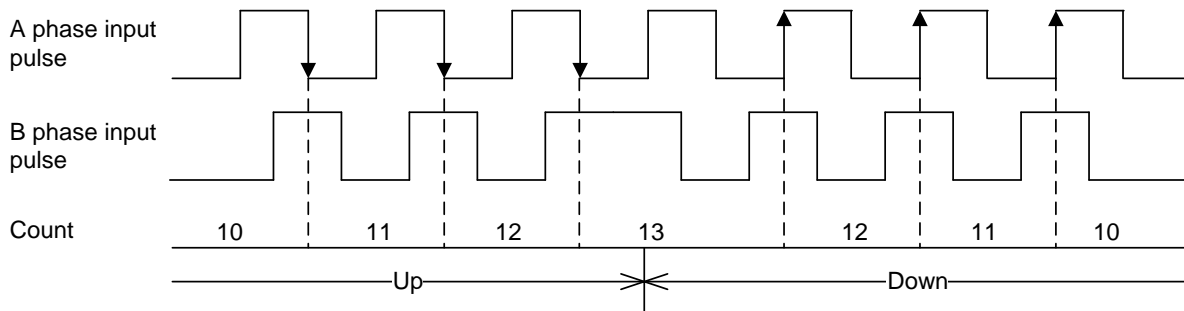

(2) 2 phase 2 multiplication input

When input pulse of A phase is ahead of B phase input pulse, at rising and falling edge of A phase input pulse, Up count is operated.

When input pulse of B phase is ahead of A phase input pulse, at rising and falling edge of A phase input pulse, Down count is operated.

When 2 phase 2 multiplication input mode, Low Active and High Active mode operation is same.

Up/Down count classification	A phase pulse rising	A phase pulse falling
Phase of A and B (A-B)	Up count (+1)	Up count (+1)
Phase of A and B (B-A)	Down count (-1)	Down count (-1)

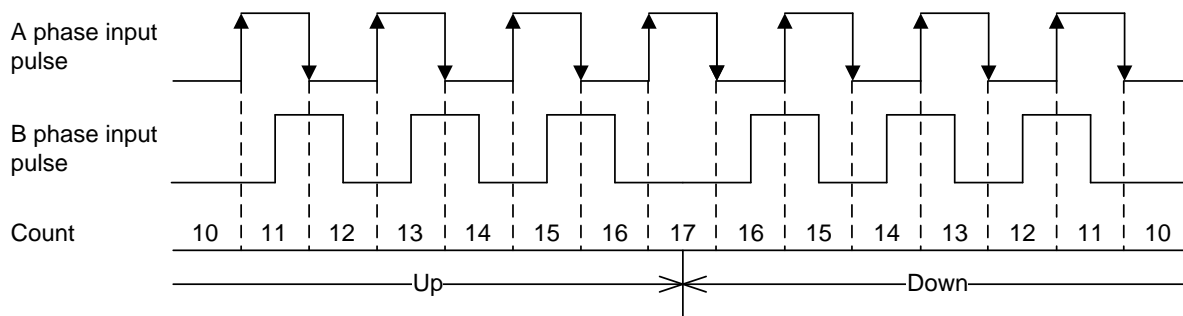

(3) 2 phase 4 multiplication input

When input pulse of A phase is ahead of B phase input pulse, at rising and falling edge of A and B phase input pulse, Up count is operated.

When input pulse of B phase is ahead of A phase input pulse, at rising and falling edge of A and B phase input pulse, Up count is operated.

When 2 phase 4 multiplication input mode, Low Active and High Active mode operation is same.

Up/Down count classification	A phase pulse rising	A phase pulse falling	A phase pulse rising	A phase pulse falling
Phase of A and B (A-B)	Up count (+1)	Up count (+1)	Up count (+1)	Up count (+1)
Phase of A and B (B-A)	Down count (-1)	Down count (-1)	Down count (-1)	Down count (-1)

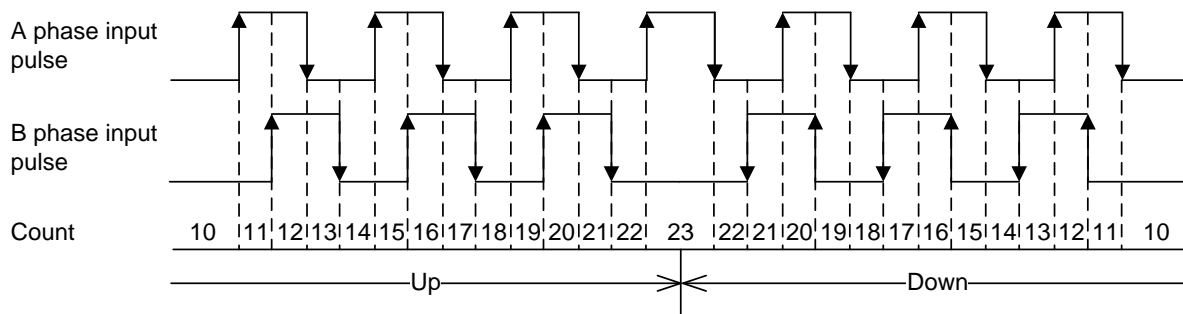

3. CWCCW(ClockWise/Counter ClockWise) input

Count is operated at rising edge of A phase input pulse or B phase input pulse and Up/Down count operation is determined by level of A or B input pulse

1) High Active Mode

Up/Down count classification	A phase pulse rising	A phase pulse falling	B phase pulse rising	B phase pulse falling
B phase input pulse Off	Up count (+1)	-	-	-
A phase input pulse Off	-	-	Down count (-1)	-

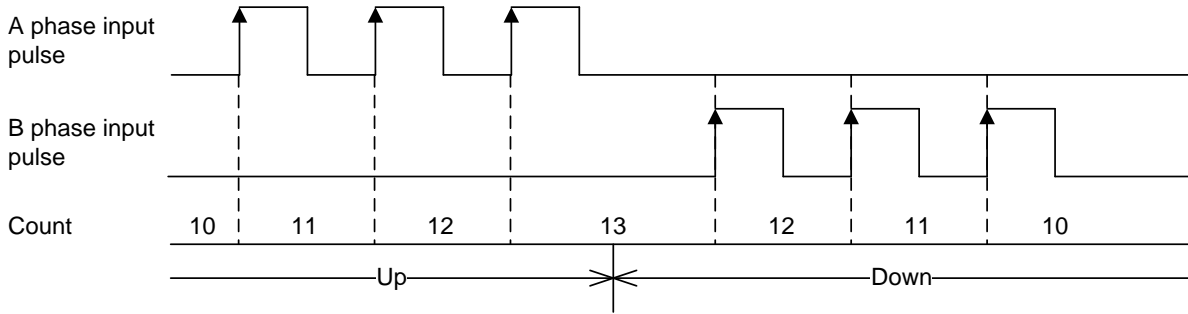

2) Low Active Mode

Up/Down count classification	A phase pulse rising	A phase pulse falling	B phase pulse rising	B phase pulse falling
B phase input pulse On	-	Up count (+1)	-	-
A phase input pulse On	-	-	-	Down count (-1)

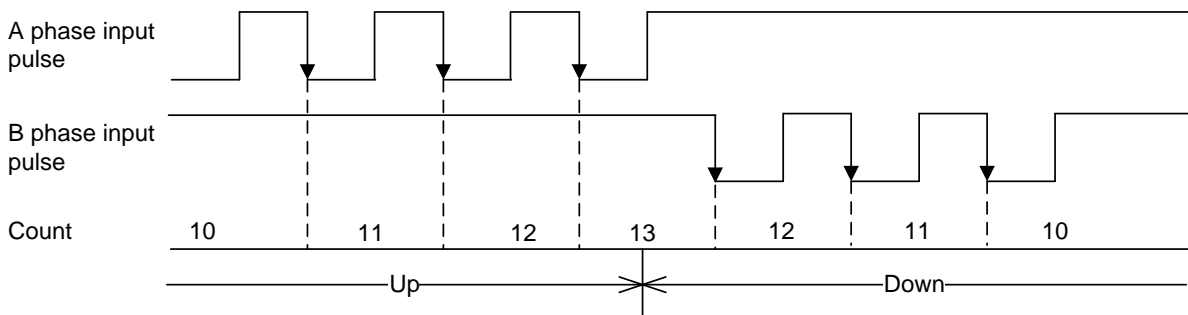

2.4.2 Count Mode

1. Linear count

(1) Linear Count range: -2,147,483,648 ~ 2,147,483,647

(2) Up count

If count value reaches the maximum value while increased, Carry will occur, and Carry occurs, count stops and increasing is not available but decreasing is available.

(3) Down count

If count value reaches the minimum value while decreased, Borrow will occur and Borrow occurs, count stops and decreasing is not available but increasing is available

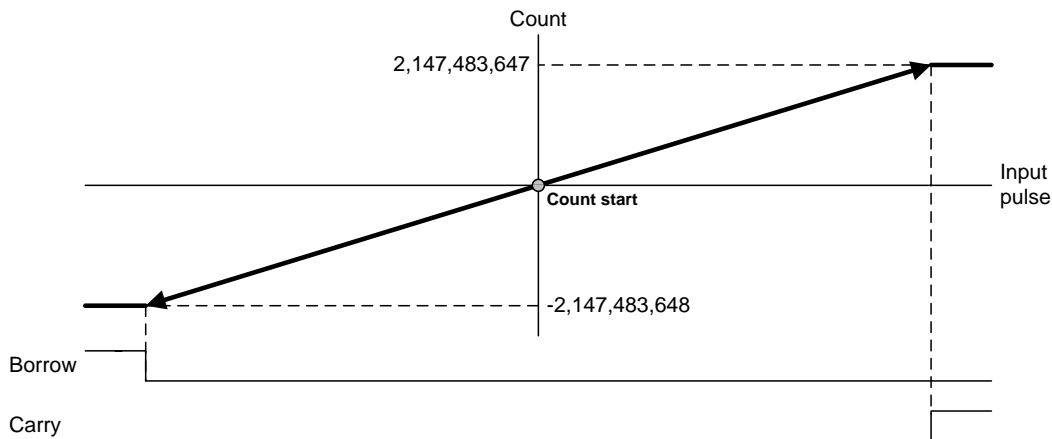

2. Ring count

(1) Count operation is executed within the user defined range repeatedly.

(2) Ring Count range: ring count min. value ~ ring count max. value

(3) Ring count display

If Ring Counted, minimum value of Ring Count is displayed as count, but the maximum value is not displayed as count.

(4) Ring count operation

(a) ring count min. value \leq Current count \leq ring count max. value

1) Up count

If count value exceeds maximum value during increasing count, Carry only occurs and count is executed starting from min. value

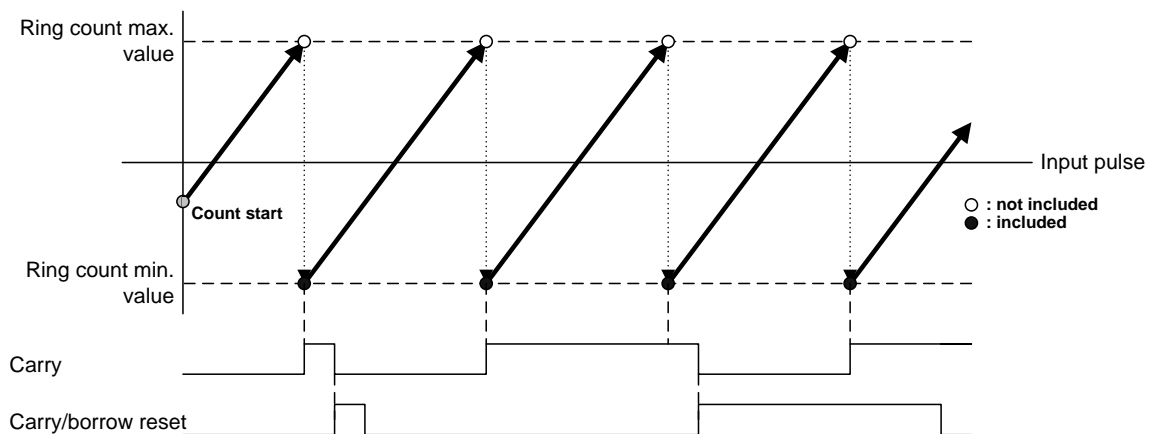

2) Down count

If count value reaches minimum value during decreasing count, Borrow only occurs and count is executed starting from max. value

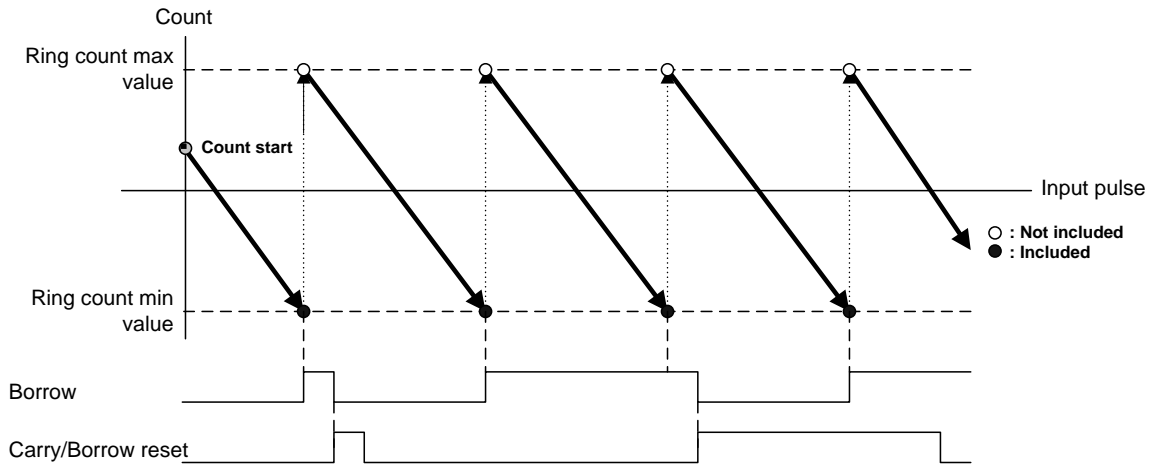

(b) $-2,147,483,648 \leq \text{current count} < \text{ring count min. value}$ or $\text{ring count max. value} < \text{current count} \leq 2,147,483,647$

1) Up count

If count reaches ring count max. value, it changes into ring count min value and carry occurs and count is executed until 2,147,483,647. If count exceeds 2,147,483,647, count is changed into -2,147,483,648 and executed repeatedly.

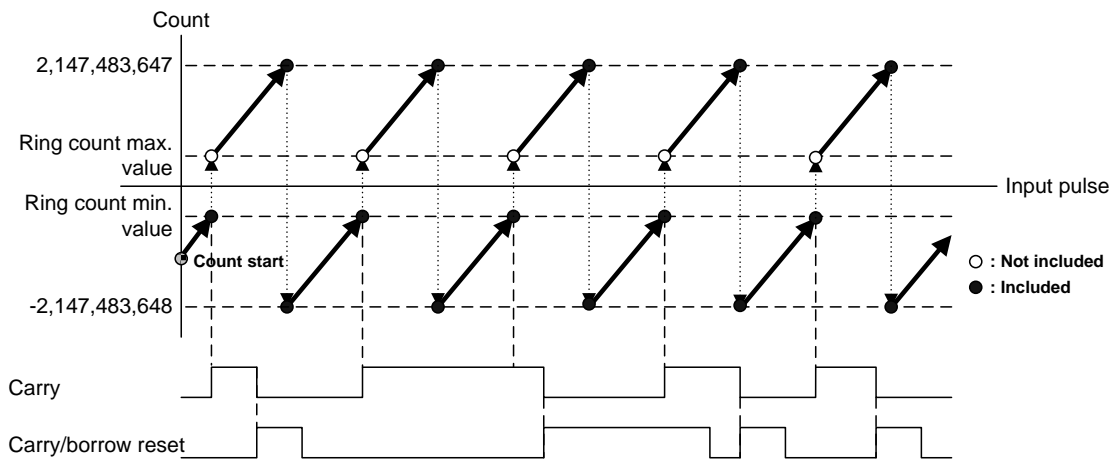

2) Down count

If count reaches min. value, borrow occurs and count is changed into ring count max. value. Count is executed until 2,147,483,647. If count reaches -2,147,483,648, count is changed into 2,147,483,648 and executed again.

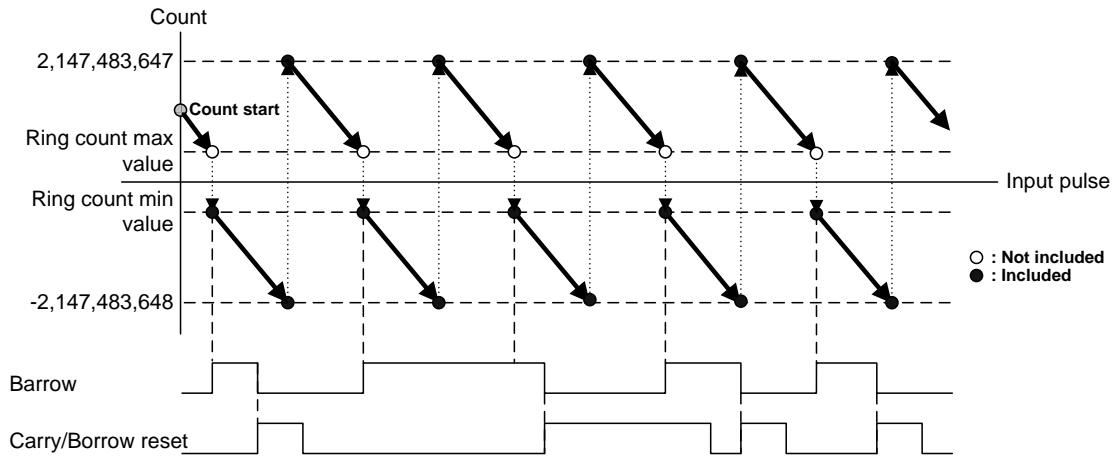
**Notes**

When setting ring count max/min value, if current count is out of range of ring count, module assumes that that is mistake of user and LED flickers and error occurs. If the user executes preset operation and changes the current count to be within ring count range, LED is off and error disappears.

2.4.3 Preset

(1) When Enable Preset is On, current count is changed into preset setting value. Only with setting of preset, current count is not changed and you have to execute the Enable Preset to change the current count.

(2) Operation method

(a) Internal preset

Setting preset value → Enable Preset On

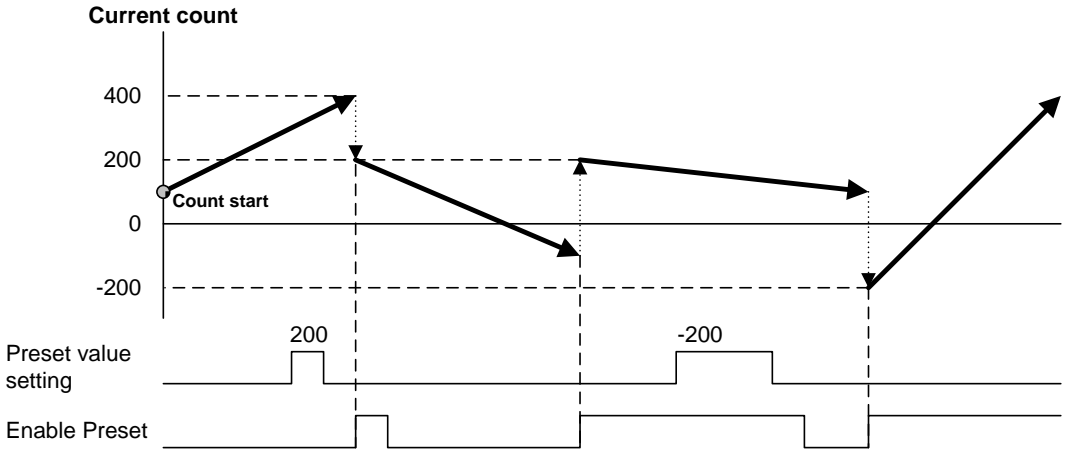

(b) External preset

Setting preset value → External Preset selection command On → External Preset Input signal On

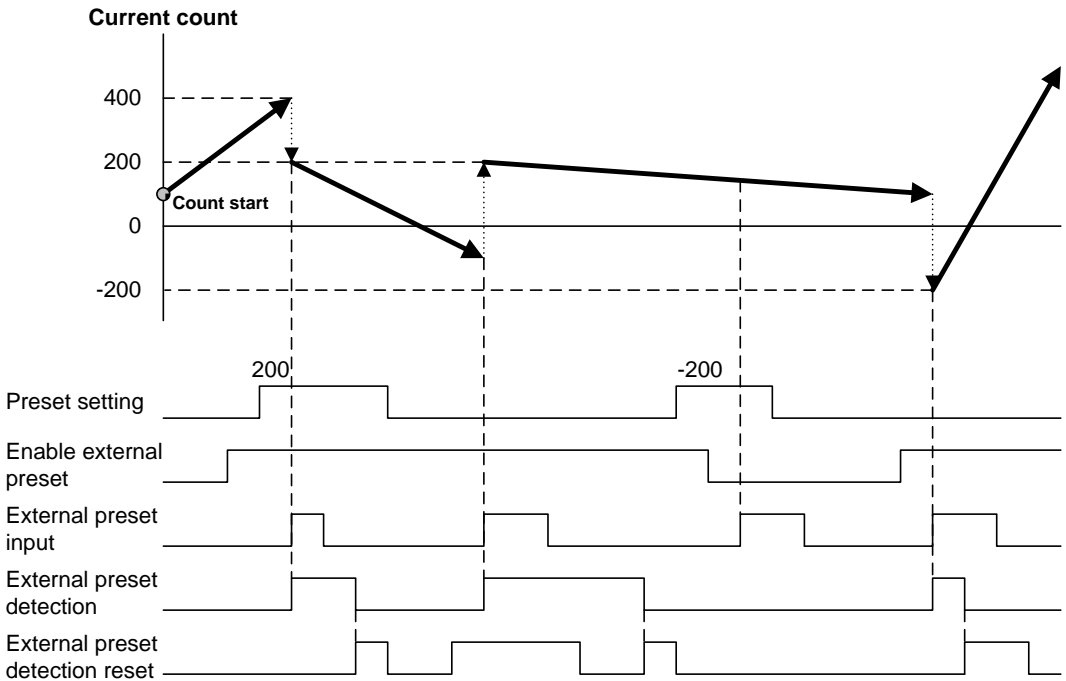

Notes

- (1) To use preset function by external input signal, set Enable Preset as 1 (On), turn on external preset input signal.
- (2) If you execute the preset by external input signal, external preset detection becomes 1 (On), When external preset detection is 1(On), external preset is not executed. In order to change external preset detection as 0 (Off), turn on external preset detection reset..

2.4.4 Compared output

- (1) High Speed counter module has a compared output function used to compare present count value with compared value in size to output as compared.
- (2) Available compared outputs are 2 for 1 channel, which can be used separately.
- (3) Compared output conditions are 7 associated with $<$, \leq , $=$, $>$, $\leq\leq$, $\geq\geq$
- (4) In order to make actual comparison enabled after compared output condition set, the compared enable signal is to be On, at this time, output is displayed only on program (U device or Global variable), and in order to send out the actual external output with LED turned On, the output enable signal is to be On.

1. Preset value $<$ Compared value

If counted present value is less than compared value, output is sent out, and if present value increases to be equal to or greater than compared value, output is not sent out.

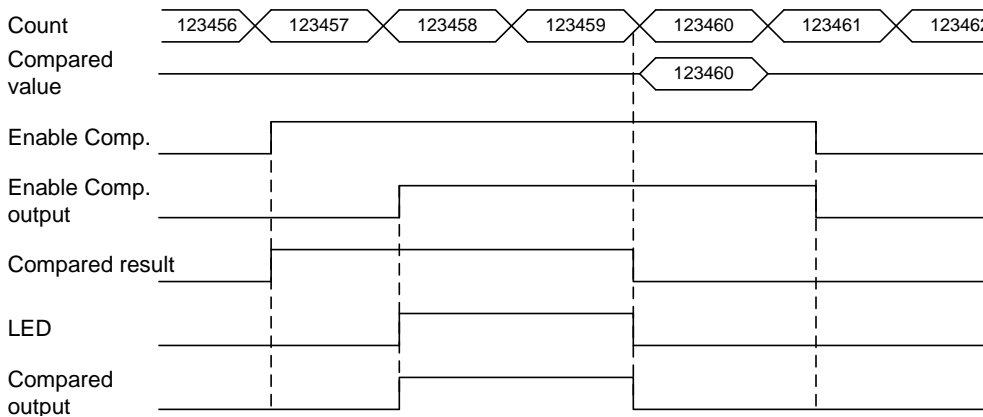

Notes

- (1) Compared result can be checked at U device for XBM,XBC, Global variable for XEC
- (2) Compared output is a signal to be output at external terminal (A03, A04, B03, B04).

2. Count value \leq Compared value

If present count value is less than or equal to compared value, output is sent out, and if count value increases to be greater than compared value, output is not sent out.

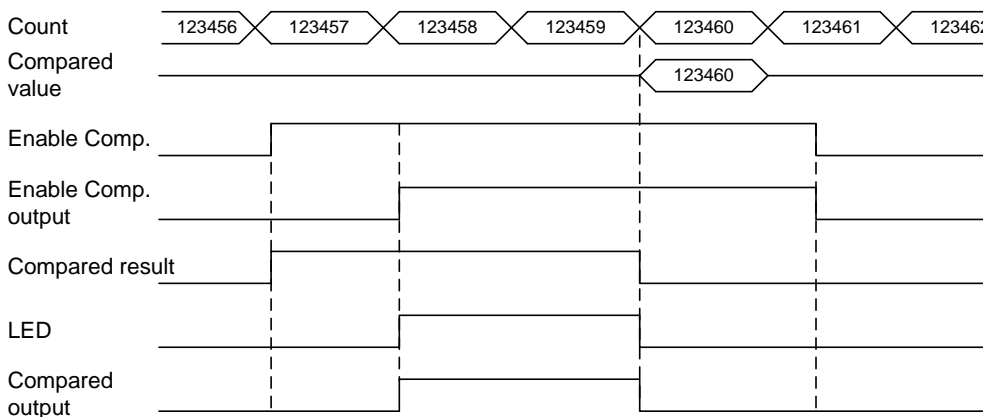

3. Count value = Compared value

If present count value is equal to compared value, output is sent out, and even if count value increases to be greater or less than compared value, output is kept On. In order to turn the output Off, identical reset signal is to be On.

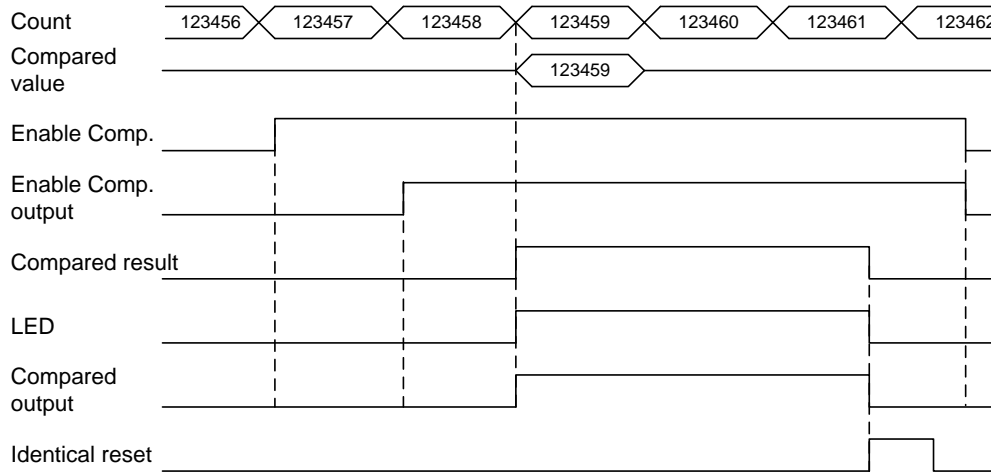

4. Count value ≥ Compared value

If present count value is greater than or equal to compared value, output is sent out, and if count value decreases to be less than compared value, output is not sent out.

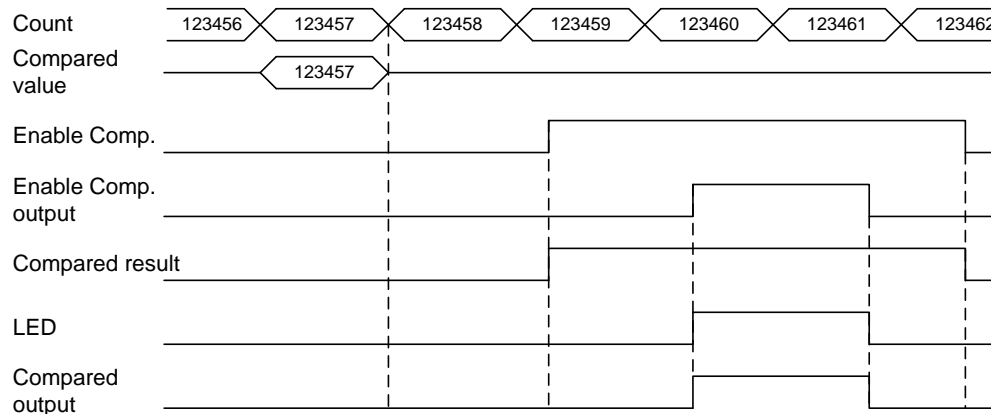

5. Count value > Compared value

If present count value is greater than compared value, output is sent out, and if count value decreases to be less than or equal to compared value, output is not sent out.

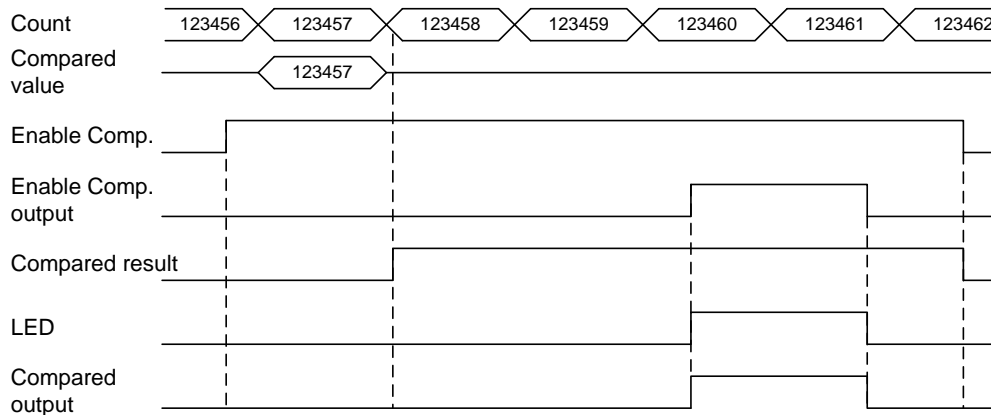

6. Compared value min. ≤ Count value ≤ Compared value max.

If present count value is greater than or equal to compared value 1 and less than or equal to compared value 2, output is sent out, and if count value increases/decreases to exceed compared value's range, output is not sent out.

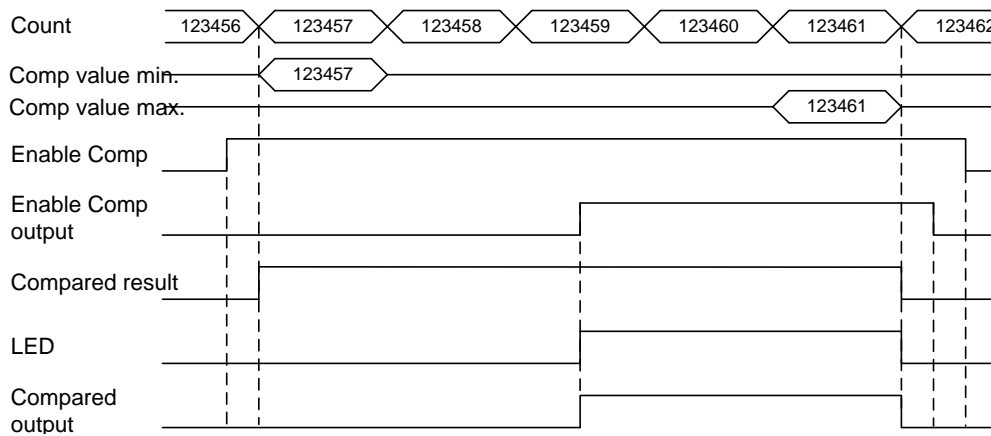

7. Count value \leq Compared value min., Count value \geq Compared value max.

If present count value is less than or equal to compared value 1 and greater than or equal to compared value 2, output is sent out, and if count value increases/decreases to exceed compared value's range, output is not sent out.

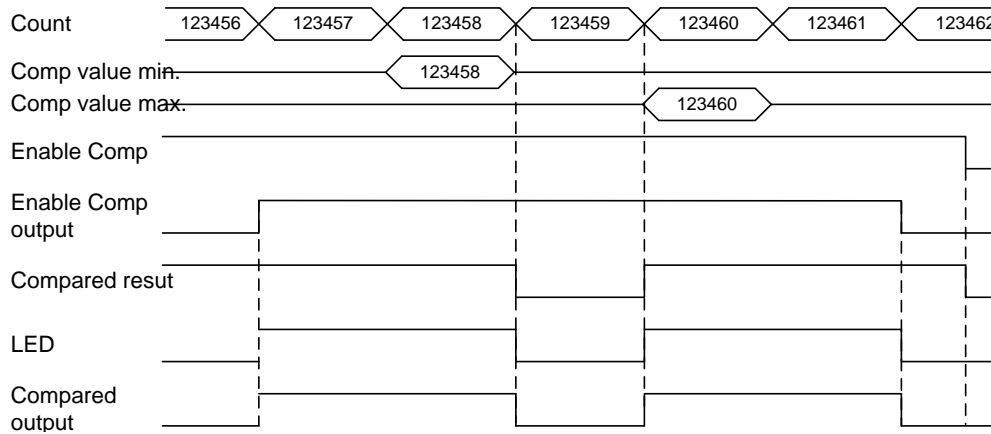

8. When main unit plc stopped, output signal by compared value out status setting.

When main unit plc stopped, you can select to keep an output or prohibit an output through compared output status setting

Remark

- (1) The output is changed to Off regardless of compared value of compared output when basic unit is stopped if the present state can't output.
- (2) The output is changed to On→Off regardless of compared value of compared output when basic unit is stopped if the present state can't output.
- (3) The output is changed to compared flag On→Off at the active status mode of compared function compared value of compared output when basic unit is stopped if the present state can't output.

2.4.5 Carry Signal

1. Carry Signal occurs
 - (1) When count range maximum value of 2,147,483,647 is reached during Linear Count.
 - (2) When maximum value of Ring Count changed to the minimum value during Ring Count.
2. Count when Carry Signal occurs
 - (1) Count stops if Carry occurs during Linear Count.
 - (2) Count does not stop even if Carry occurs during Ring Count.
3. Carry reset
The Carry generated can be cancelled by Carry/Borrow reset signal On.
As mentioned below, no cleared.

Count Mode	Description
Linear Count	In case current count value 2,147,483,647
Ring Count	Current count change to minimum value of ring count by occurring carry. it makes present value keep.

2.4.6 Borrow Signal

1. Borrow signal occurs
 - (1) When count range minimum value of -2,147,483,648 is reached during Linear Count.
 - (2) When minimum value of Ring Count changed to the maximum value during Ring Count user-defined Ring Count minimum value maximum value.
2. Count when Borrow signal occurs
 - (1) Count stops if Borrow occurs during Linear Count.
 - (2) Count does not stop even if Borrow occurs during Ring Count..
3. Borrow reset
The Borrow generated can be cancelled by Carry/Borrow reset signal On.
As mentioned below, no cleared.

Count Mode	Description
Linear Count	In case current count value -2,147,483,648
Ring Count	Current count change to maximum -1 of value of ring count by occurring borrow. it makes present value keep.

2.4.7 Auxiliary mode

High Speed counter module provides 6 auxiliary modes as well as basic count function and compared output function. In order to use the auxiliary modes, auxiliary mode enable signal is to be "On".

Notes

- (1) To use auxiliary function by program, turn off the external auxiliary mode and turn on Enable Auxiliary
- (2) To use auxiliary function by an external signal, turn on the external auxiliary mode and turn on External auxiliary input signal (GATE).

1. Count clear

- (1) When Auxiliary Mode enable signal is On, present count value is set to 0.
- (2) Setting method
Set auxiliary mode setting mode to 1 → Auxiliary mode enable signal On.

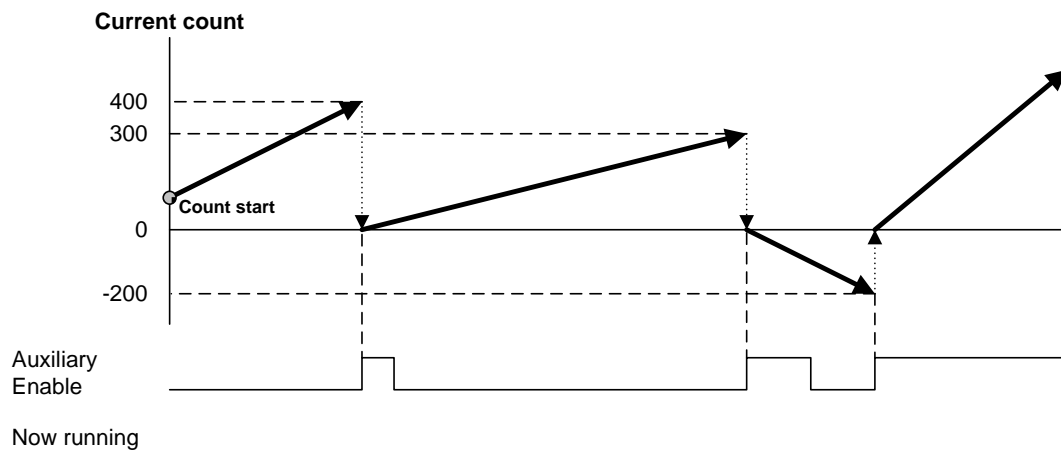

2. Count Latch

(1) When auxiliary mode enable signal is On, present count value is latched

(2) Setting method

Set auxiliary mode setting mode to 2 → Auxiliary mode enable signal On

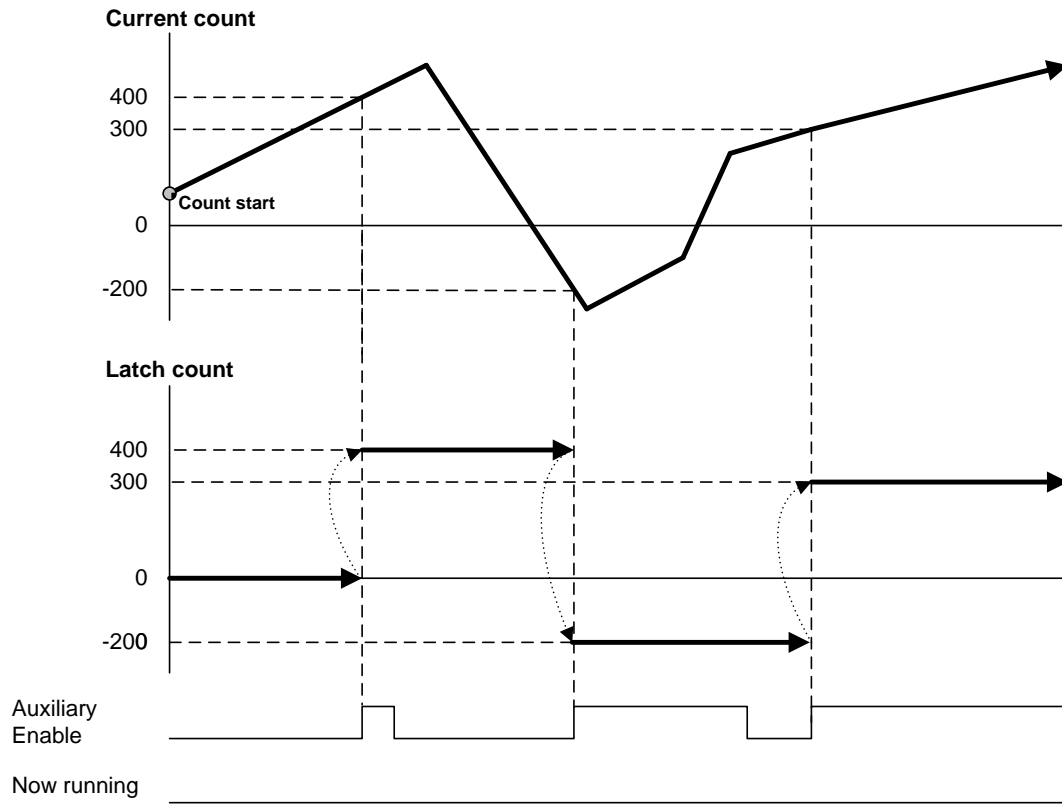

3. Sampling Count

(1) When auxiliary mode enable signal is On, it counts for a specified time.

(2) Setting method

Set auxiliary mode setting mode to 3 → Time setting → Auxiliary mode enable signal On

(3) Display during auxiliary mode operation

Sampling Count function operates for a specified time when auxiliary mode enable signal is On, and the auxiliary mode in progress signal is On at the same time.

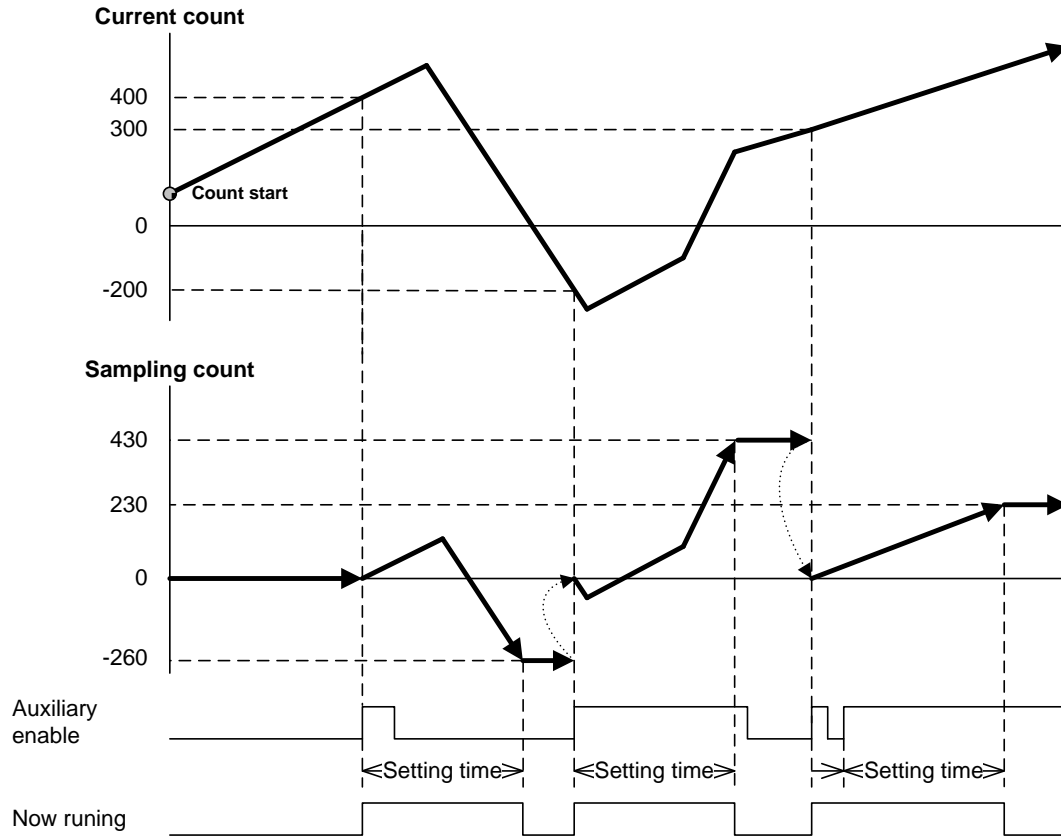

4. Input Frequency Measure

- (1) While auxiliary mode enable signal is On, it indicates frequency of input pulse. Unit of input frequency conforms to setting of frequency unit.
- (2) Setting method
Set auxiliary mode setting mode to 4 → Set frequency unit → Auxiliary mode enable signal On.
- (3) Frequency input mode can be specified as below, whose update cycle and resolution will be decided based on the applicable mode.

Frequency unit setting	Unit [Hz]	Updated cycle [ms]
0	1	1000
1	10	100
2	100	10
3	1000	1

(4) Display during auxiliary mode operation

While auxiliary mode enable signal is On, Now Running signal is on

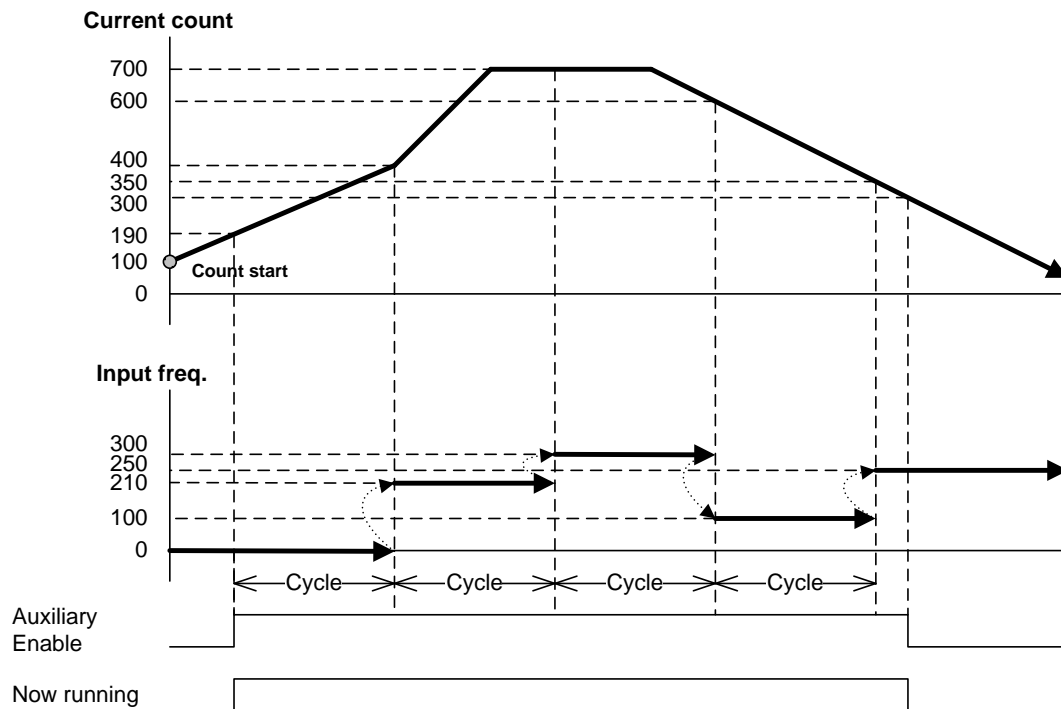

※ On the figure, unit is 1Hz and updated cycle is 1000msec.

5. Revolution/Unit time

(1) While auxiliary mode enable signal is On, it calculates the number of input pulses for a specified time and indicates the revolution/unit time. To use this function, setting time and No. of pulse/revolution should be set.

(2) Setting method

Set auxiliary mode setting mode to 5 setting → Time setting, No. of pulse/revolution → Auxiliary mode enable signal On.

(3) With the number of pulses per revolution input and time set to 1 minute (60000ms), the value of RPM is displayed.

(4) Display during auxiliary mode operation

While auxiliary mode enable signal is On, Now Running signal is on

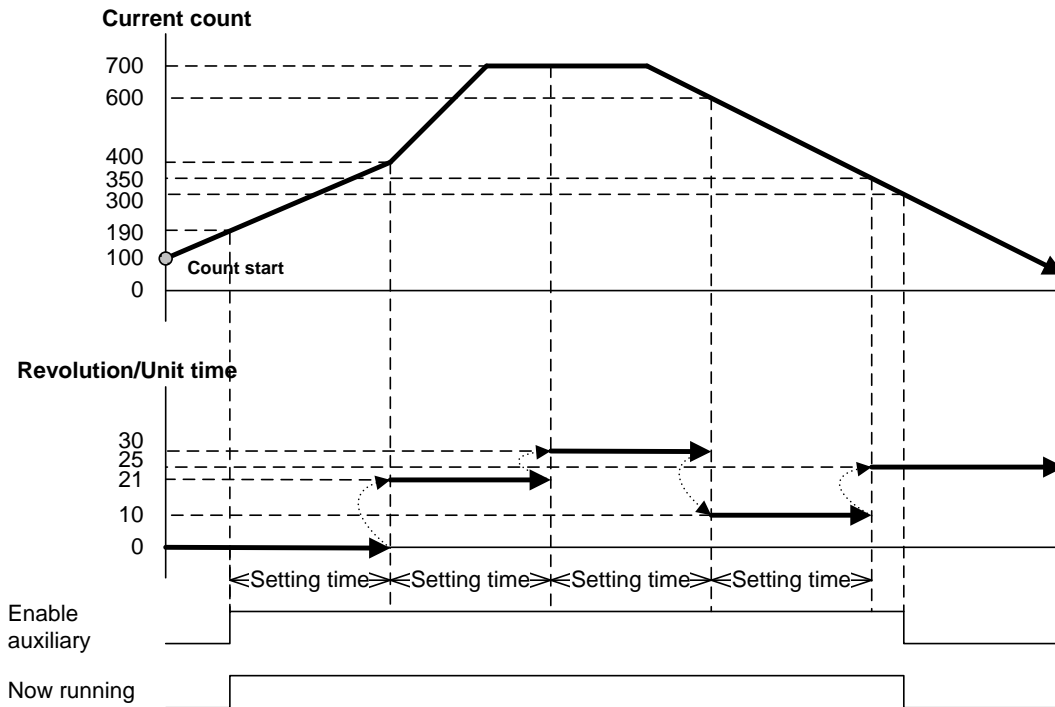

※ On the figure, the number of pulse/revolution is set to be 10.

6. Count Disable

(1) While auxiliary mode enable signal is On, count operation stops.

(2) Setting method

Set auxiliary mode setting mode to 6 → Auxiliary mode enable signal On

(3) Display during auxiliary mode operation

While auxiliary mode enable signal is On, Now Running signal is on

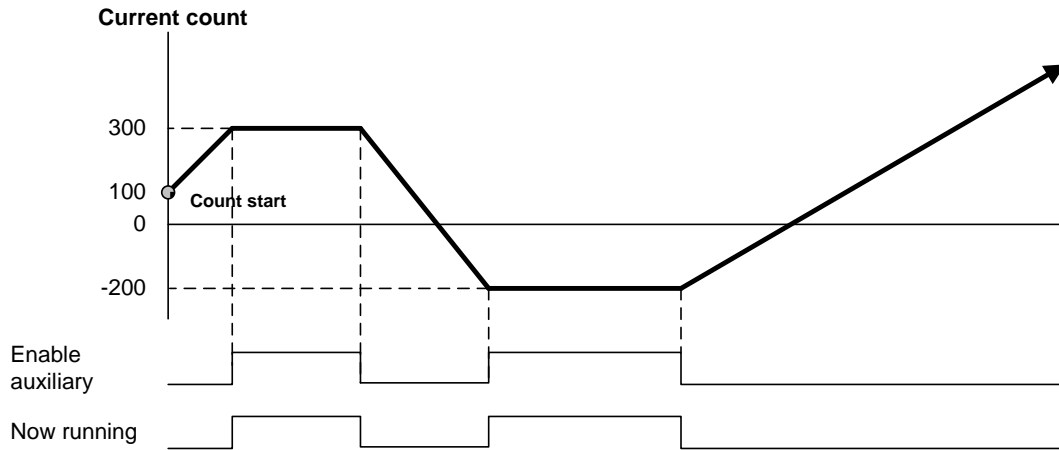

Chapter 3 Installation and Wiring

3.1 Installation

3.1.1 Installation environment

This product is of high reliance regardless of installation environment. However, for the sake of reliance and stability of the system, please pay attention to those precautions described below.

- (1) Environmental conditions
 - (a) To be installed on the control panel waterproof and dustproof.
 - (b) No continuous shocks or vibration will be expected.
 - (c) Not to be exposed to the direct sunlight.
 - (d) No dew should be caused by rapid temperature change.
 - (e) Ambient temperature should be kept 0 - 55°C.
- (2) Installation work
 - (a) No wiring waste is allowed inside PLC when wiring or drilling screw holes.
 - (b) To be installed on a good location to work on.
 - (c) Don't let it installed on the same panel as a high-voltage device is on.
 - (d) Duct or surrounded module should be farther than 50cm from the HSC.
 - (e) Make sure that the PE terminal is grounded.

3.1.2 Handling precautions

Precautions for handling High Speed counter module are as described below from the opening to the installation.

- (1) Don't let it dropped or shocked hard.
- (2) Don't remove PCB from the case. It will cause abnormal operation
- (3) Don't let any foreign materials including wiring waste inside the top of the module when wiring.
Remove foreign materials if any inside.
- (4) Don't install or remove the module while powered On.

3.2 Wiring Precautions

3.2.1 Wiring Precautions

- (1) Pay attention to do action about external noise during wiring for the pulse input of the high counter module.
- (2) Surely use twisted pair shielded cable, grounded with 3 class applied.
- (3) Keep away from power cable or I/O line which may cause noise.
- (4) Connect A-phase only for 1-phase input.
- (5) Please take the wiring with consideration the maximum output distance of pulse generator.

3.2.2 Example of DC5V voltage output wiring

- If the pulse generator is voltage output type, example of wiring with HSC is as shown below;
- The wiring will be the same if the pulse generator (Encoder or Manual pulse generator) of voltage output type is used through Totem Pole output.

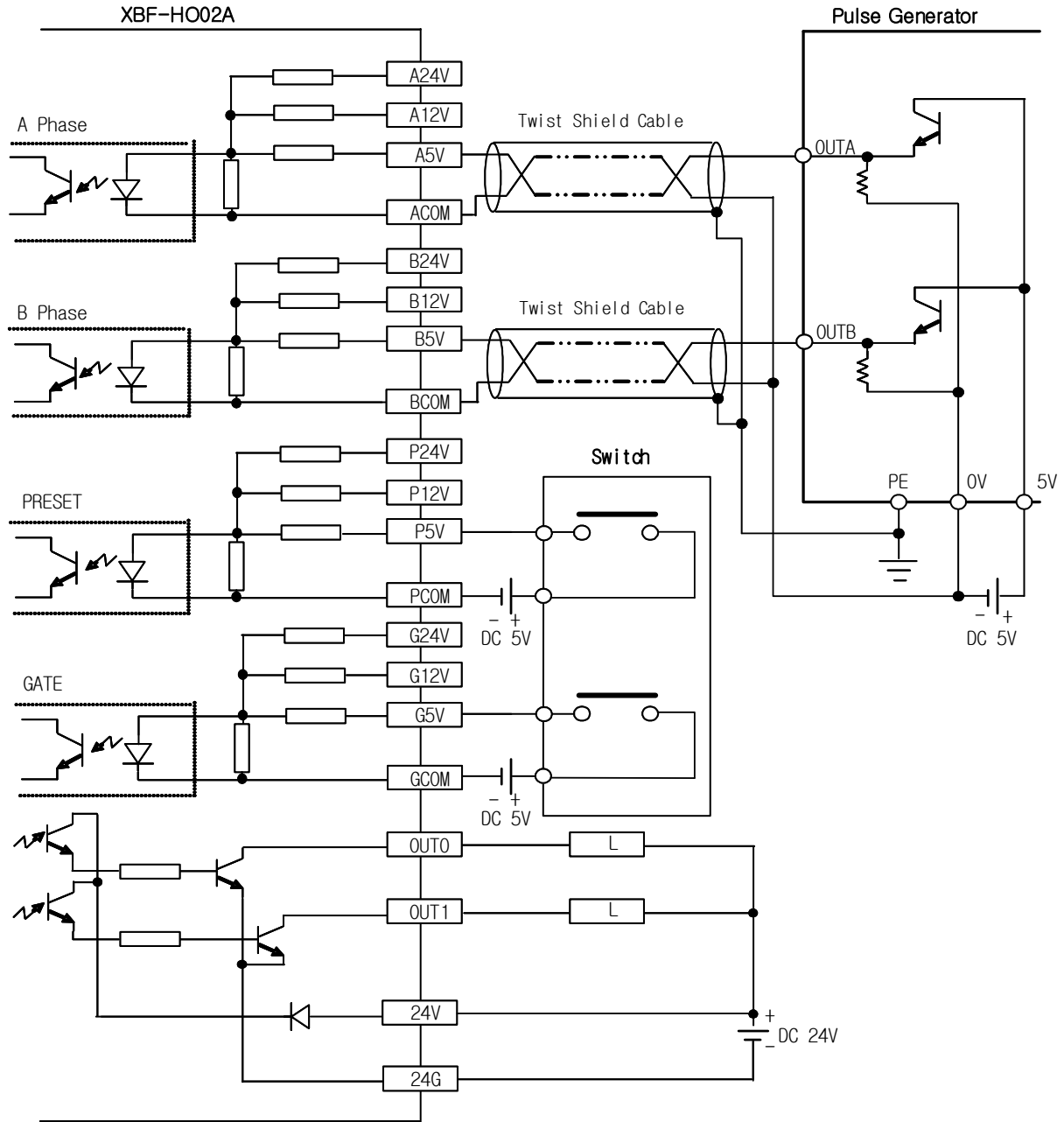

3.2.3 Example of DC12V NPN Open Collector output wiring

This is the wiring example which it used the pulse generator (Encoder or Manual pulse generator) of NPN Open Collector output type.

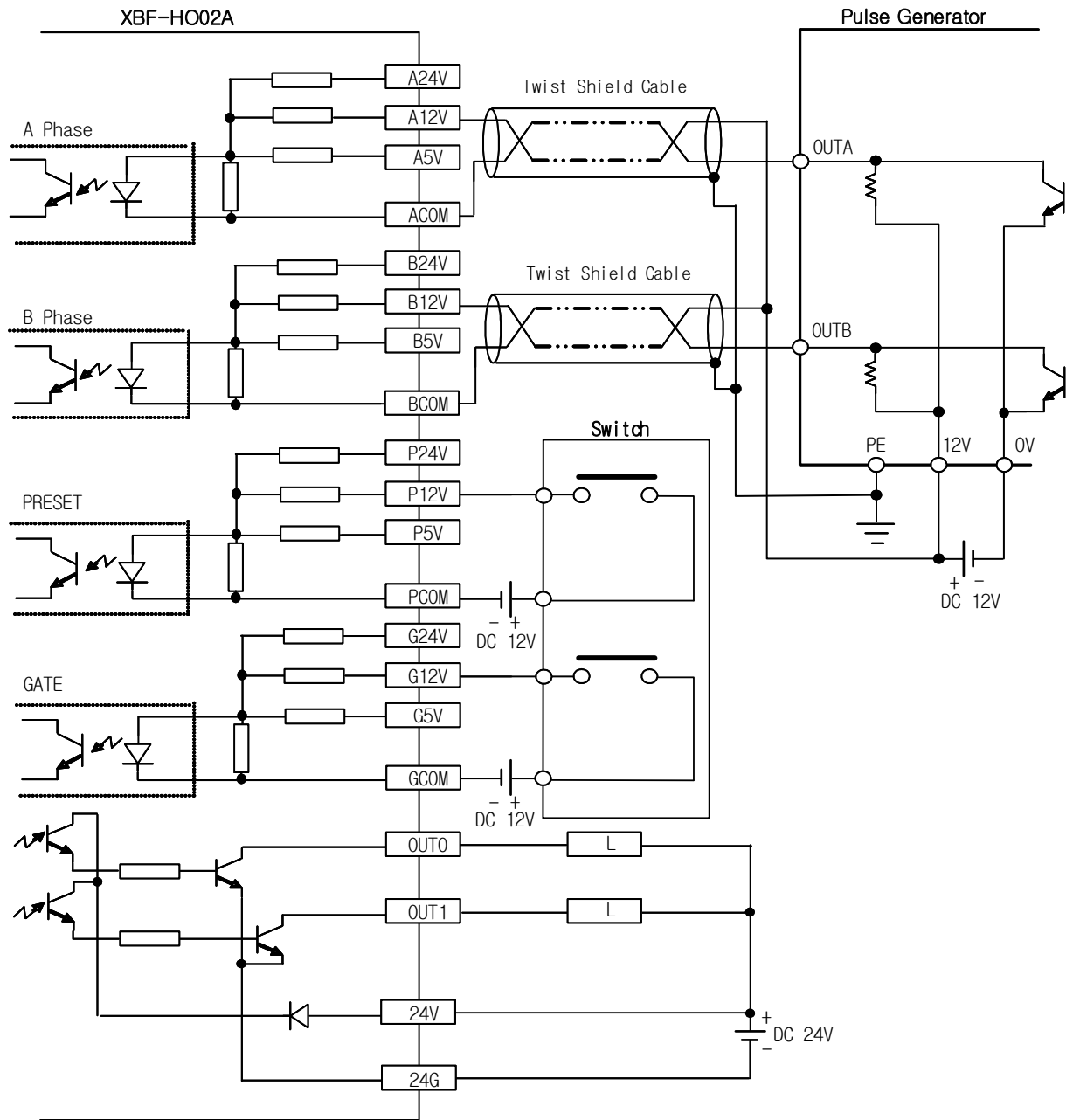

Remark

In case external line noise environment, Between pulse generator(encoder or manual pulse generator) and HSC wiring need to attach a resistance by noise to protect malfunction as below the wiring example.
 (External Pull Up Resistance use to adjust specification of external device.)

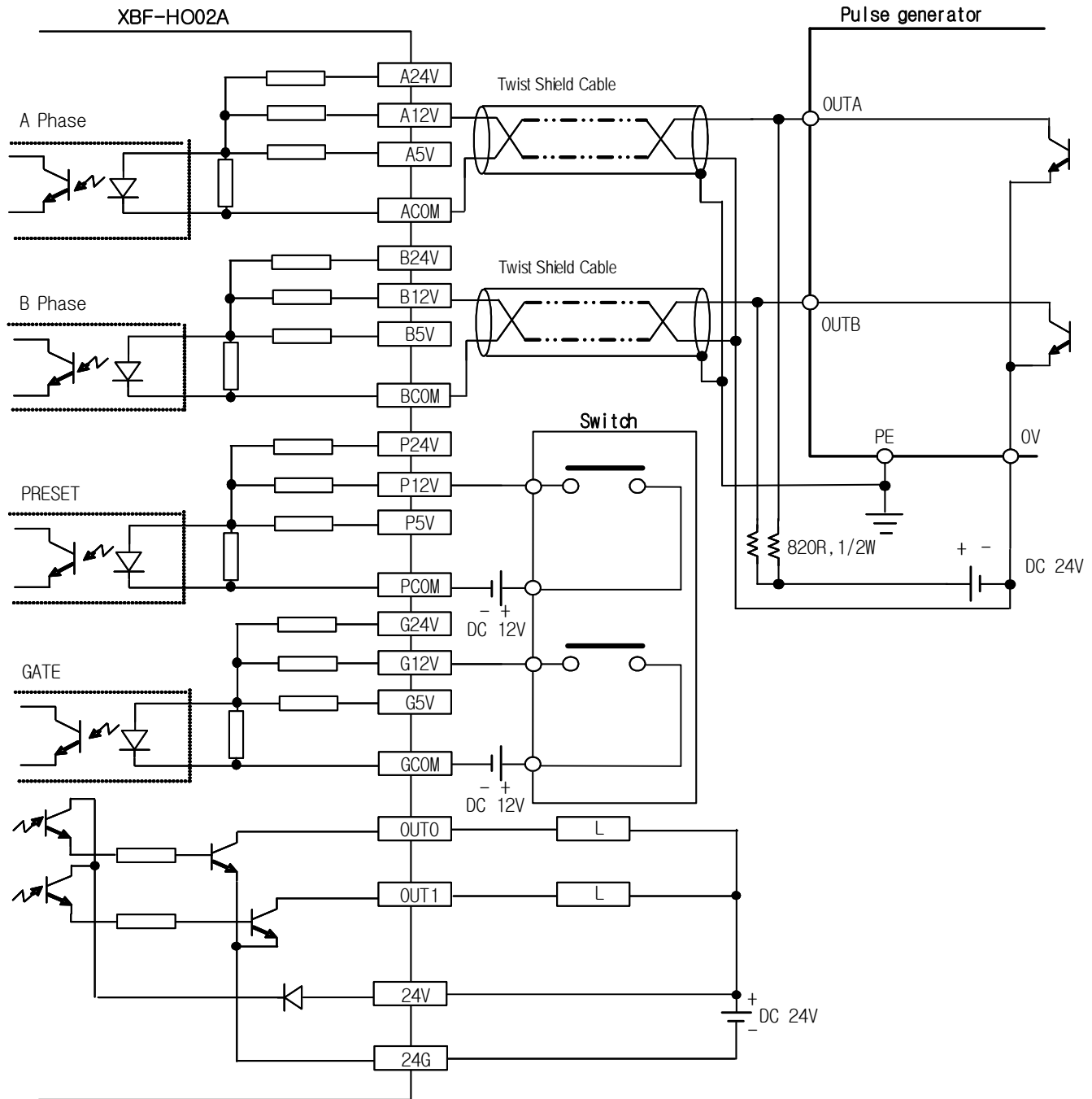

3.2.4 Example of DC24V PNP Open Collector output wiring

This is the wiring example which it used the pulse generator (Encoder or Manual pulse generator) of PNP Open Collector output type.

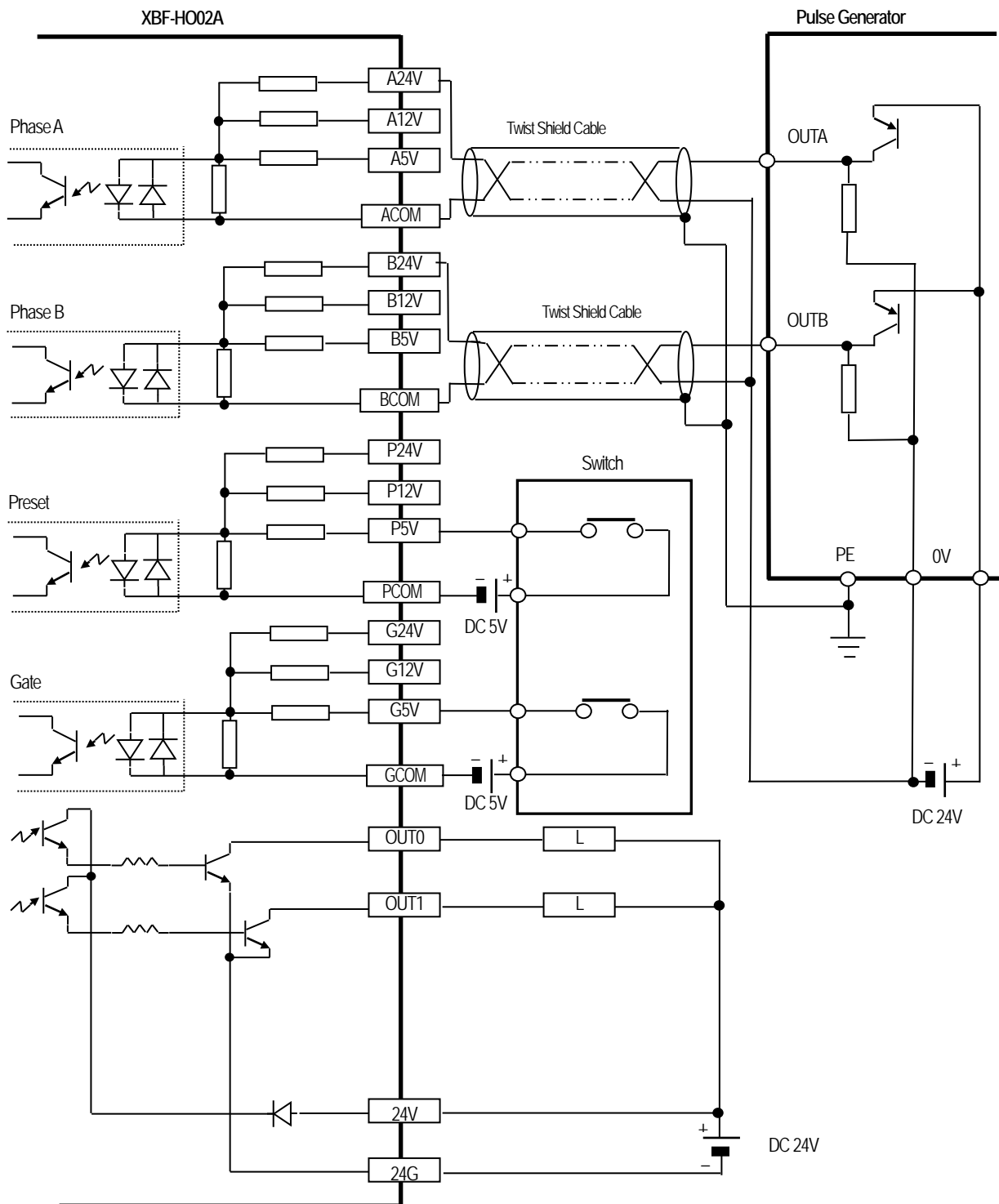

3.2.5 Example of Line Driver output wiring

This is the wiring example which it used the pulse generator (Encoder or Manual pulse generator) of RS-422A Line Driver (5V level) output type.

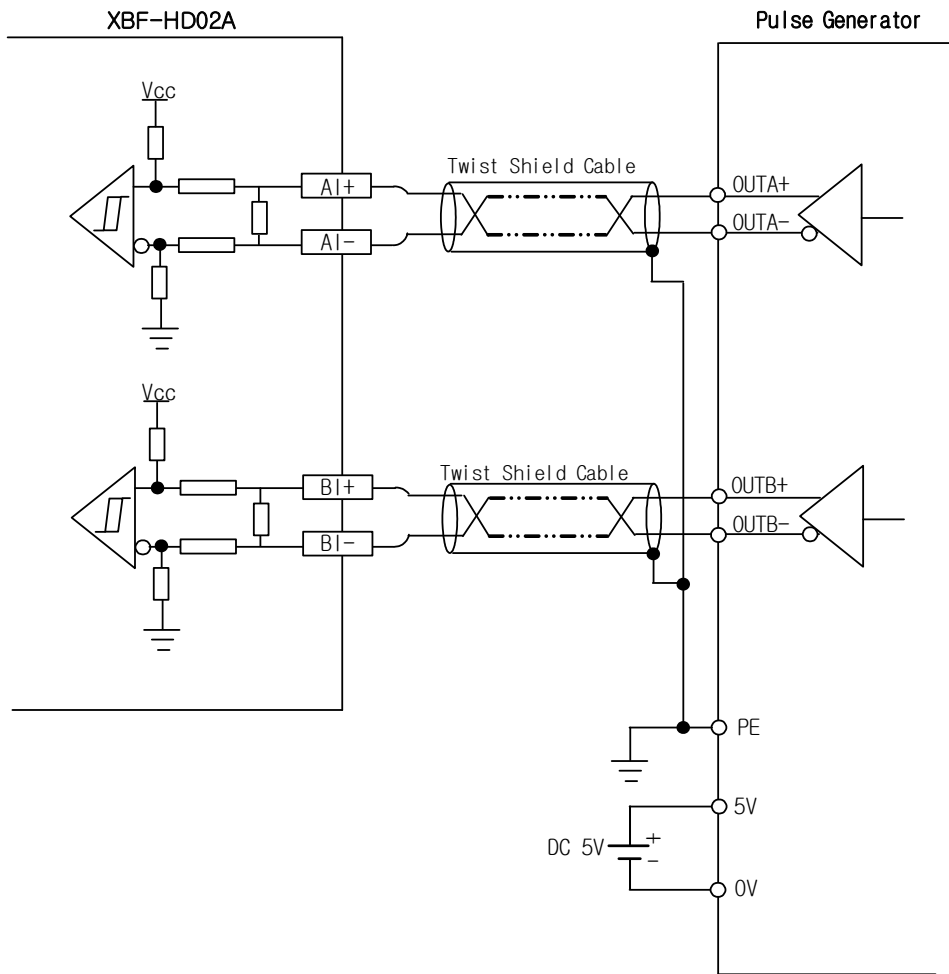

Remark

In case of 24V Level Line Driver, please connect to All+, All-, BII+, BII- terminal.
Be careful wiring and you must consider maximum output distance of pulse generator.

Chapter 4 Operation Procedures and Monitoring

Operation setting and monitor functions of XG5000 program will be described in this chapter among operation methods of High-speed counter module.

4.1 XG5000 Execution

4.1.1 Execution and Connection of XG5000

- 1) After XG5000 installed, click XG5000 execution icon to display the initial screen of XG5000 program as shown below.

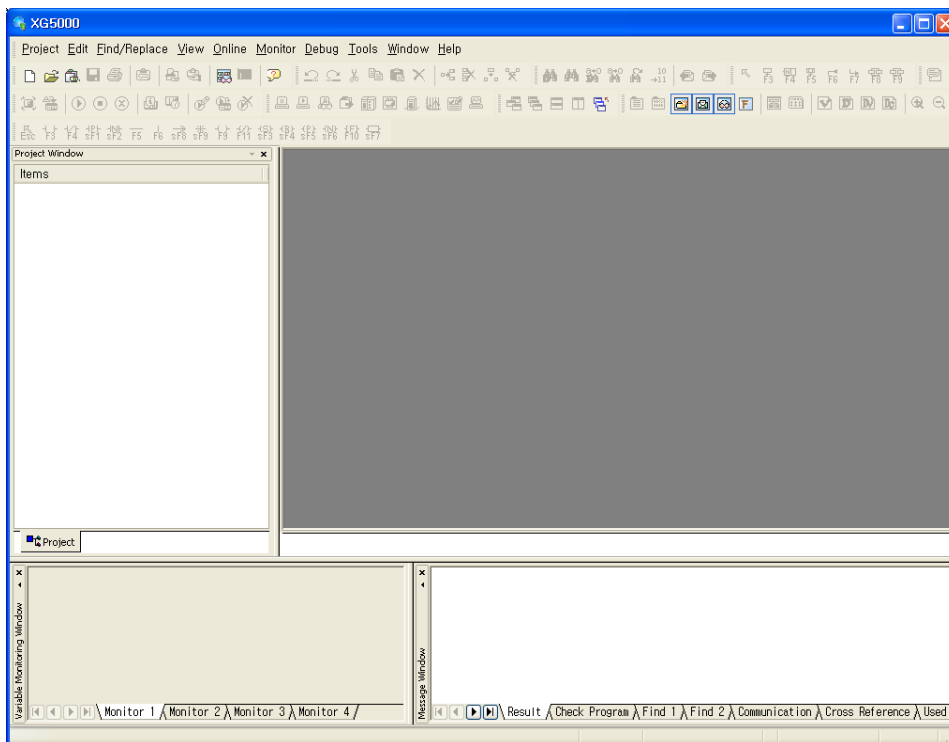

- 2) On the [Project] menu, click [New Project] or  on the icon menu to display the screen as shown below.

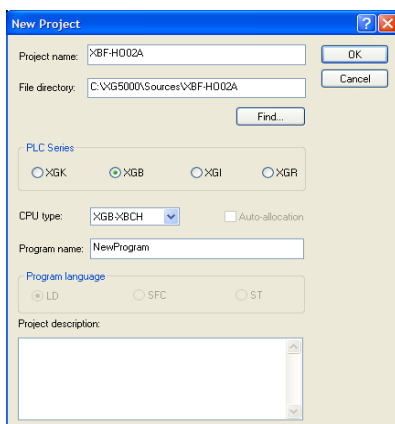

3) Project screen is as below.

Project screen of XBM series

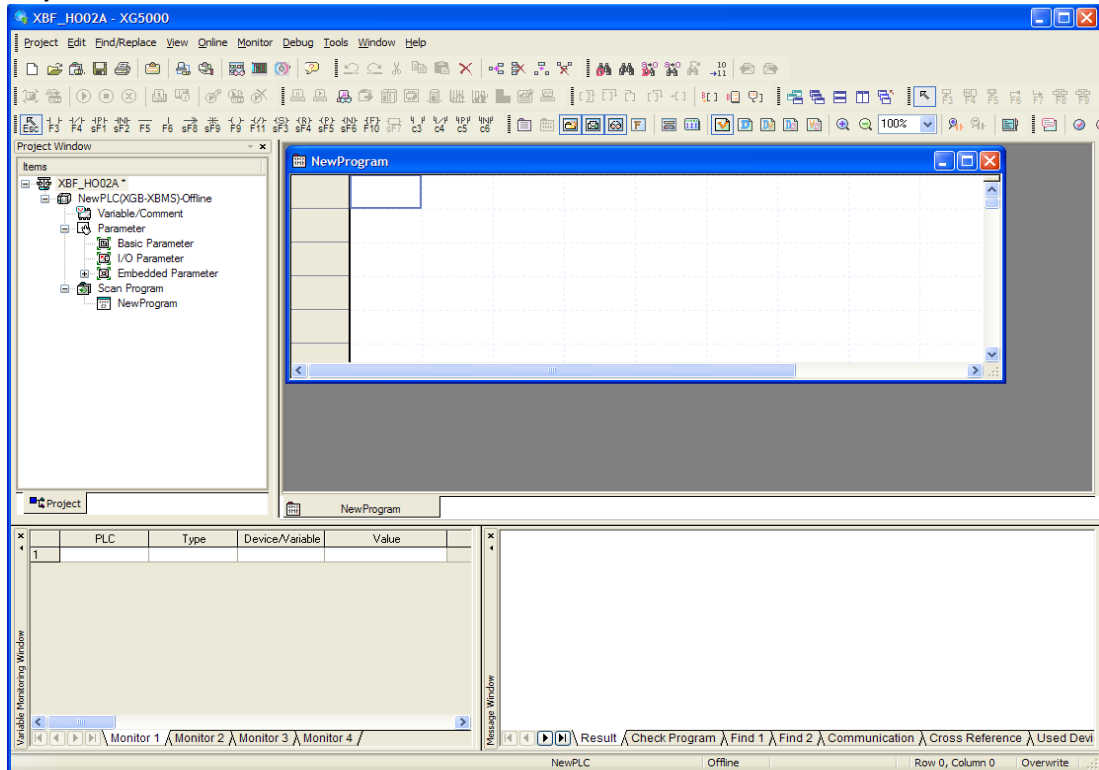

Project screen of XBC series

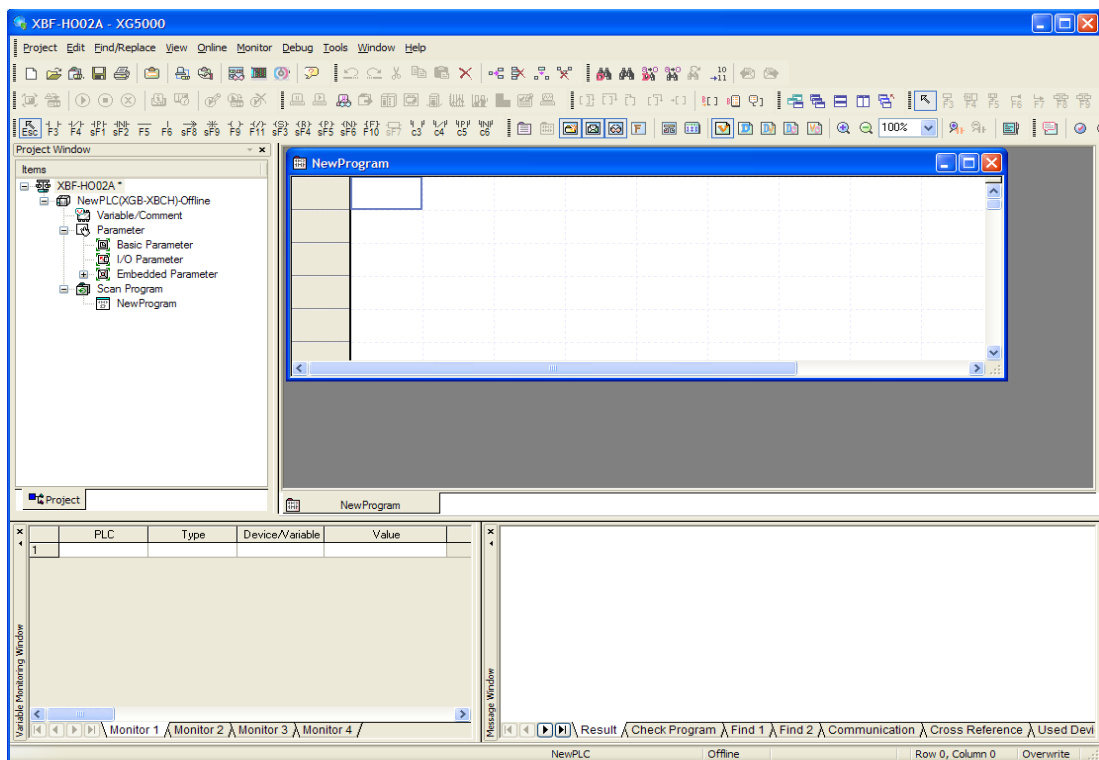

Project screen of XEC series

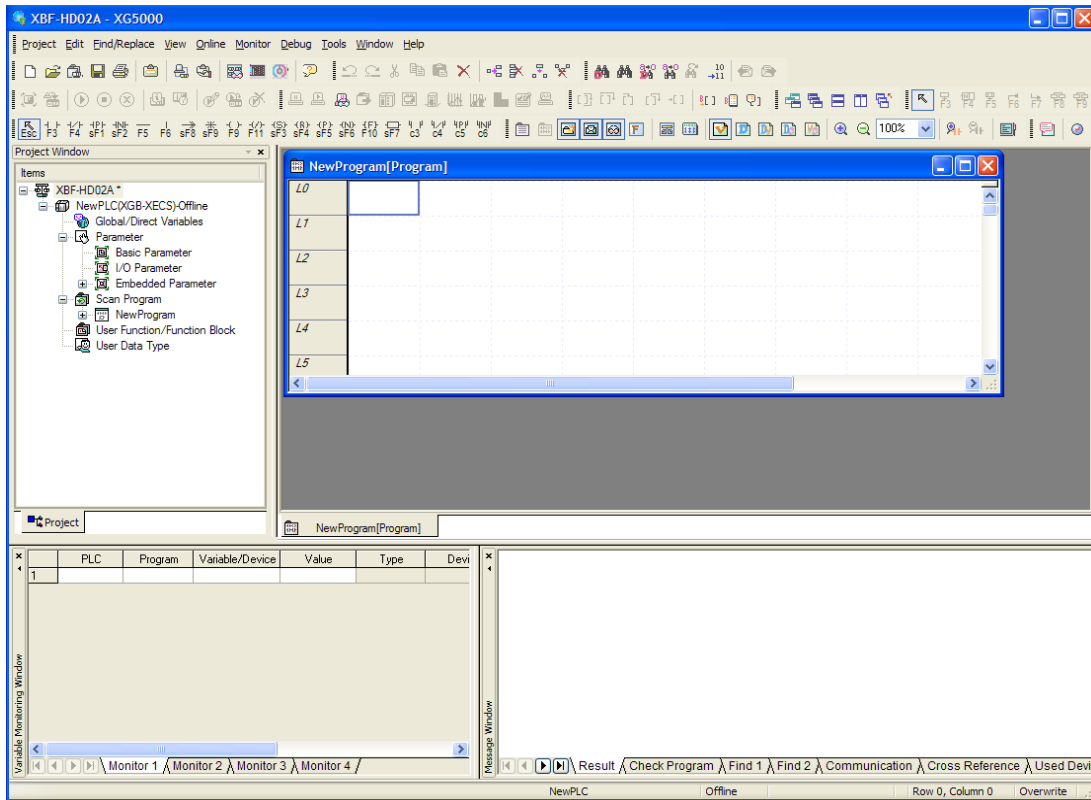

4) If a project is created, click [Online]-[Connection Settings] or  on the icon menu to specify the connection method and connection stage, and then click [Settings] to specify the communication port and the communication speed(115,200).

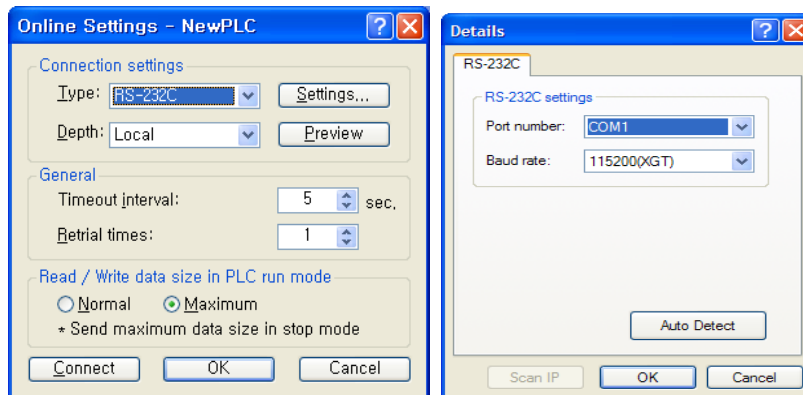

5) After all settings complete, click [Online]-[Connect] or  on the icon menu. Click [Communication] tab on [Message Window] to check the connection.

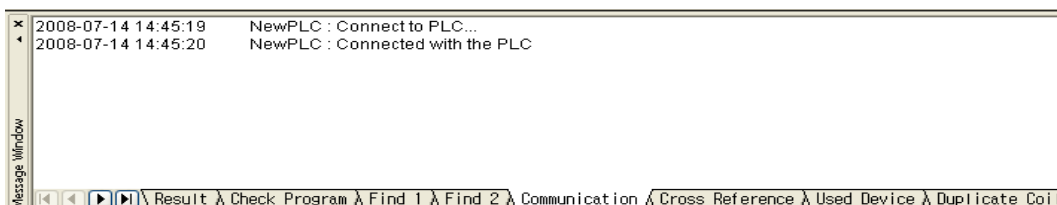

4.2 Parameters Setting

This description is based on XG5000 Project of XBC series, because it is the same to parameter setting method of XBM/XBC/XEC series.

4.1.2 Parameters setting

- 1) Double-click [I/O parameters] on the [Project Window] to the left of the project created on XG5000.
- 2) If [I/O parameters setting] window is displayed, click the module area of the applicable slot to select the applicable module

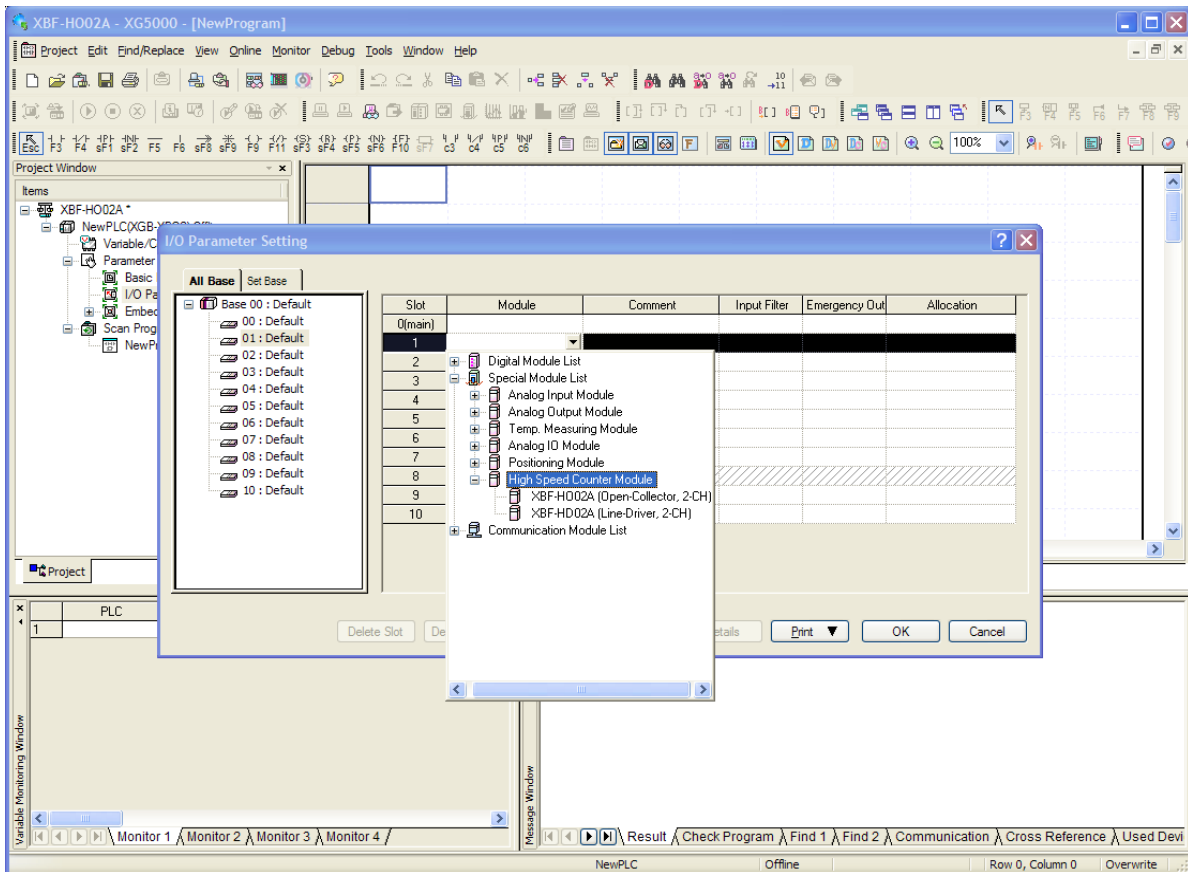

3) Double-click the applicable slot selected to specify the parameters, or click [Details] to display the screen where parameters can be set.

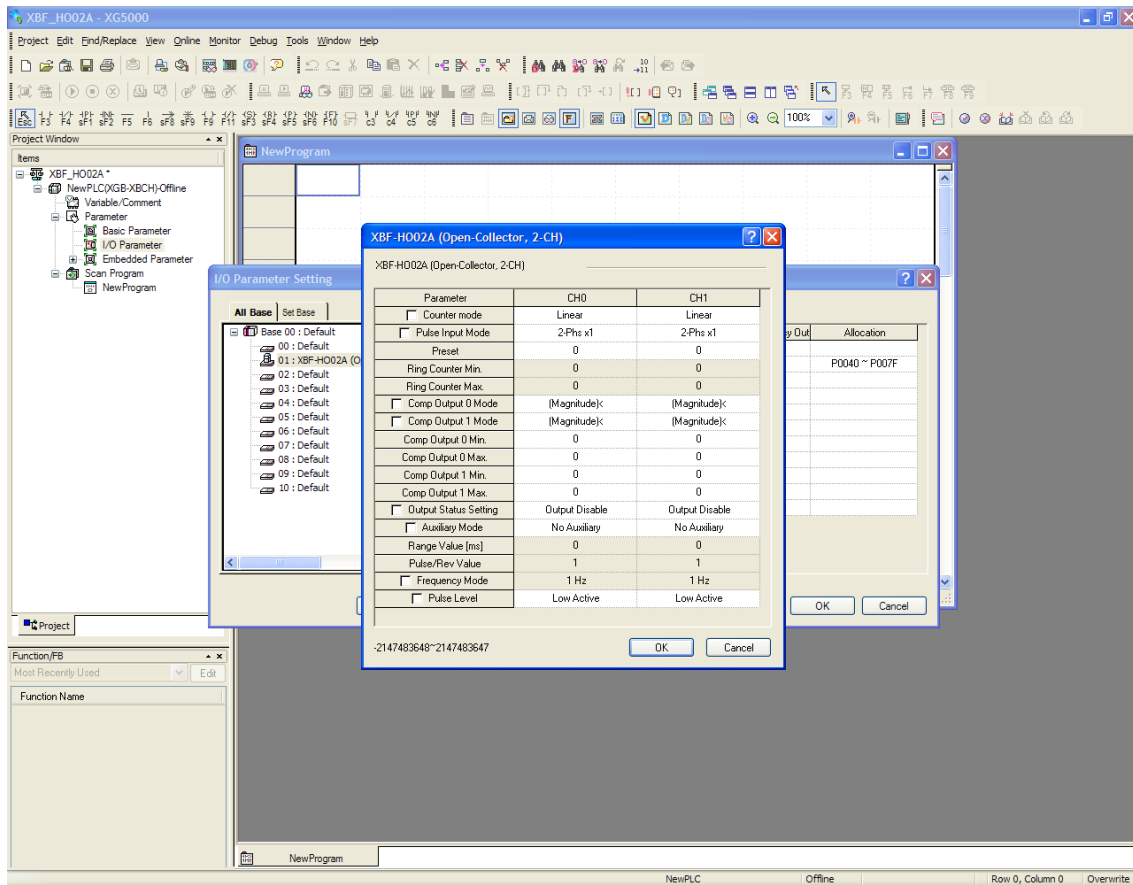

4) Set parameters as necessary for operation on the parameters setting window.

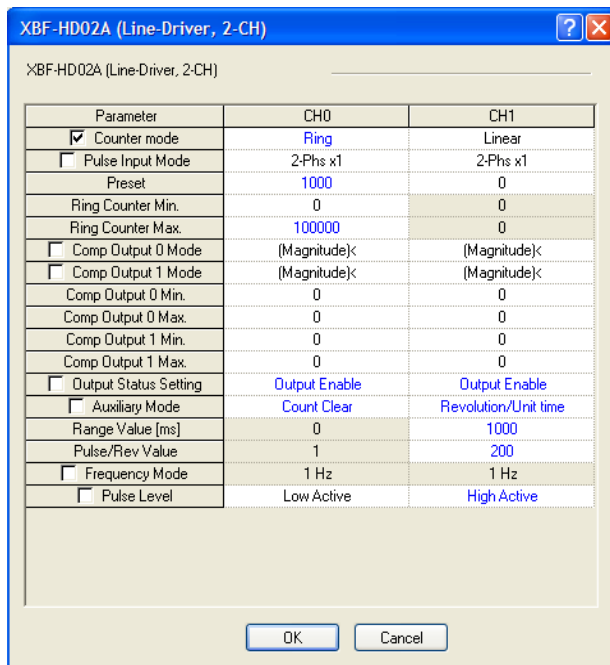

※ You must make the scan program to change parameter of the high speed counter module during CPU RUN mode.

4.3 Monitoring and Test

This description is based on XG5000 Project of XBC series, because it is the same to parameter setting method of XBM/XBC/XEC series.

4.3.1 Monitoring and Test

- 1) After connected to PLC CPU through XG5000, click [Online]-[Special Module Monitoring] or  on the icon menu to display the screen as shown below.

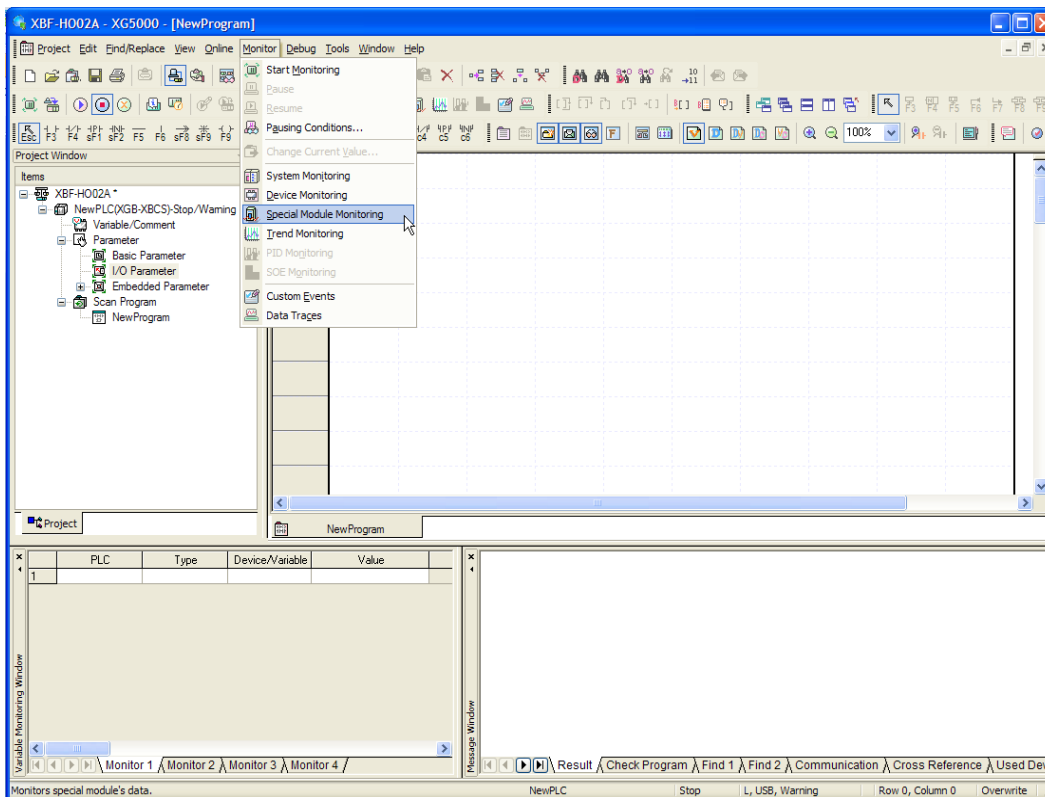

- 2) On the module list dialog box, the special modules presently installed on PLC system will be displayed.

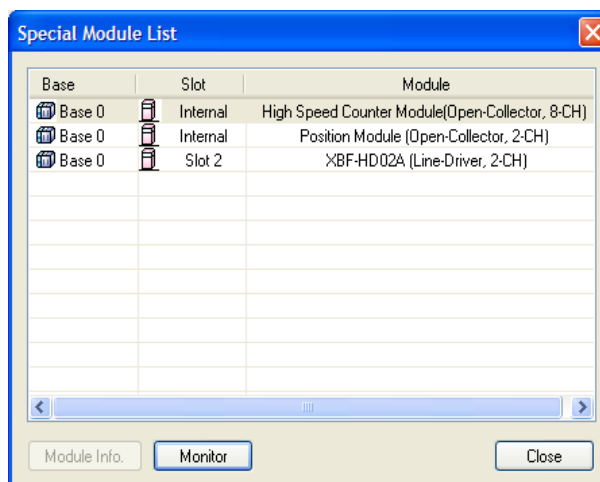

- 3) Select the applicable module and click the monitoring button to display the monitoring/ test screen as shown below, whose functions are as follows;
- On the upper monitoring screen, each special module's monitoring item values are displayed.
 - On the bottom test screen, each module's parameter items can be changed individually.
- If you click TEST button, setting values is applied to current value.

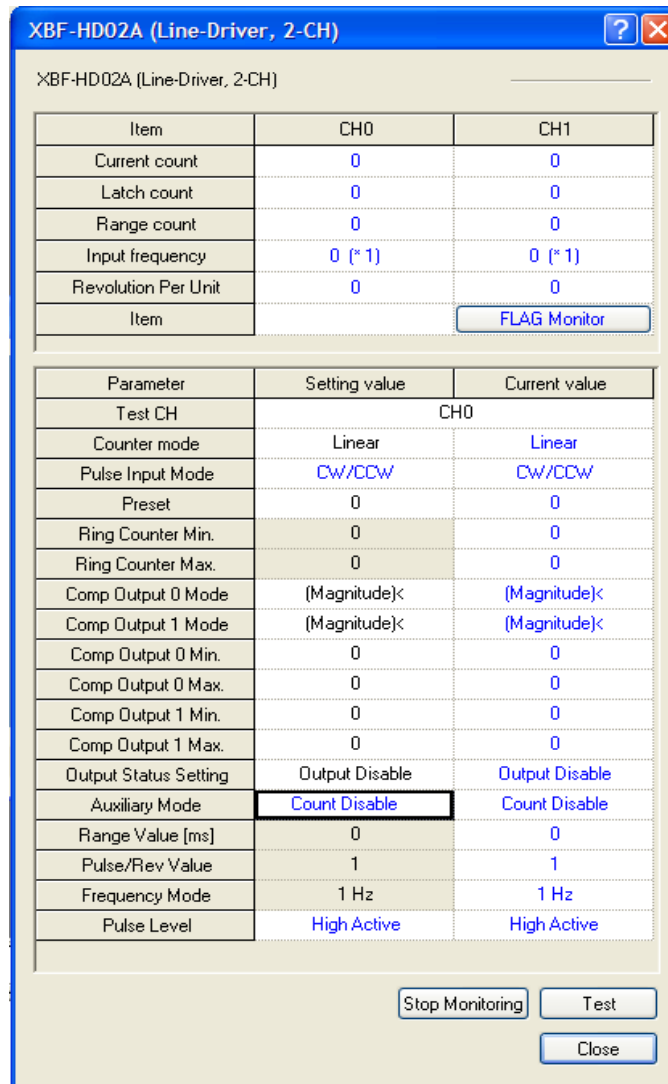

Remark

- (1) It is applied to only test operation to the parameter which changed by Test button. If test operation is concluded, the high speed counter module is operated by the parameter which was set by I/O parameter or by the scan program.
- (2) If PLC CPU module is STOP mode, it is available to test operation and monitoring function. But in case of RUN mode, it is available only to monitoring function.

- 4) In order to monitor the I/O contact status, click the applicable channel's flag monitoring button to display the monitoring screen where each I/O contact status can be checked.

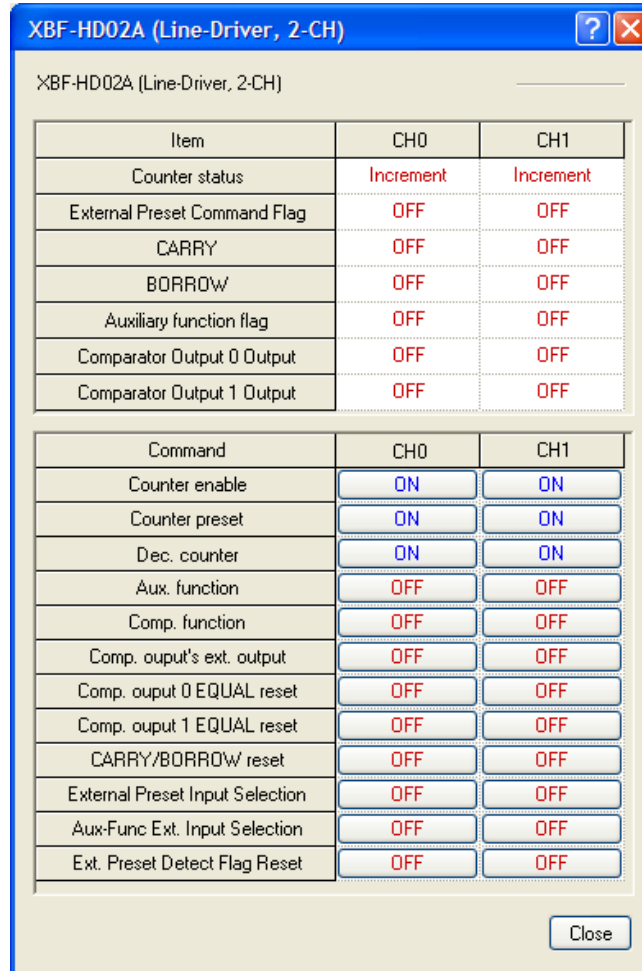

4.4 Registration of U Devices

It is described to the method to register automatically U devices in XG5000 Project of XBC series.

4.4.1 Variable/Comment screen

If you double click [Variables/Comment] of [Project Window], variables and comments which was registered already are displayed.

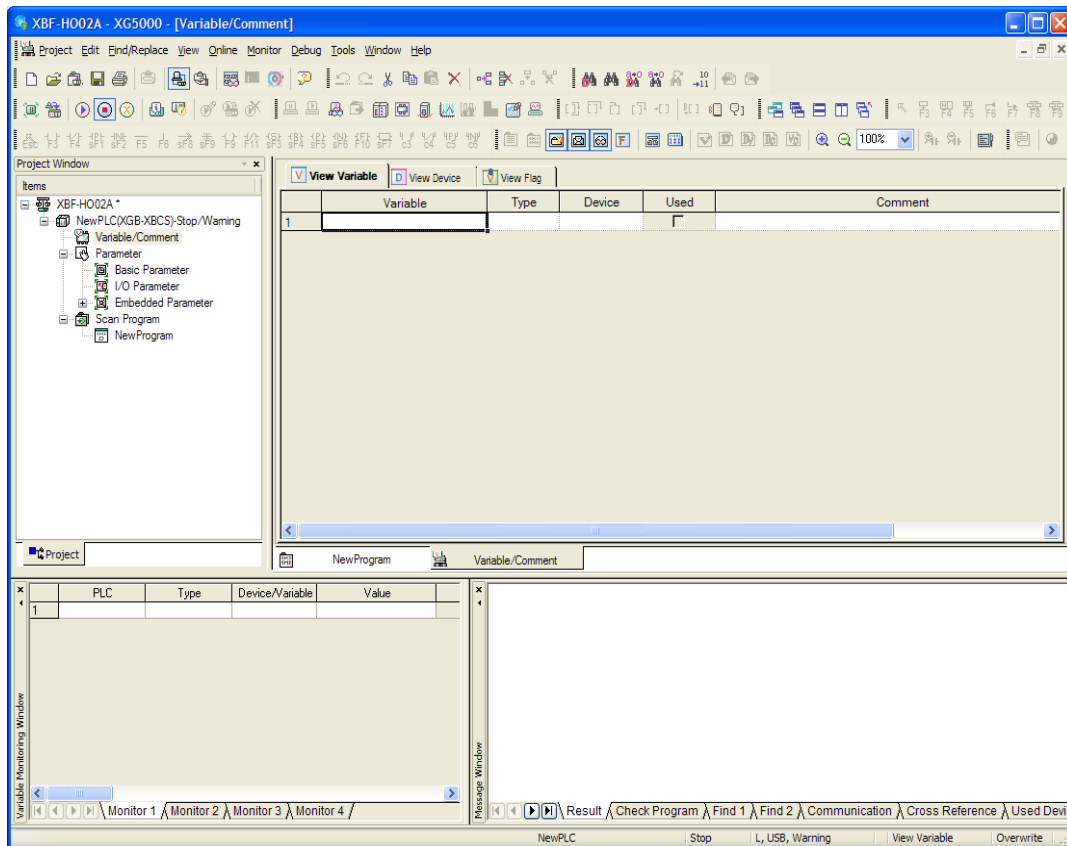

4.4.2 Registration of U Devices

- 5) Select [Edit]→[Register U Device].
(First, [Variable/Comment] window has to be executed.)

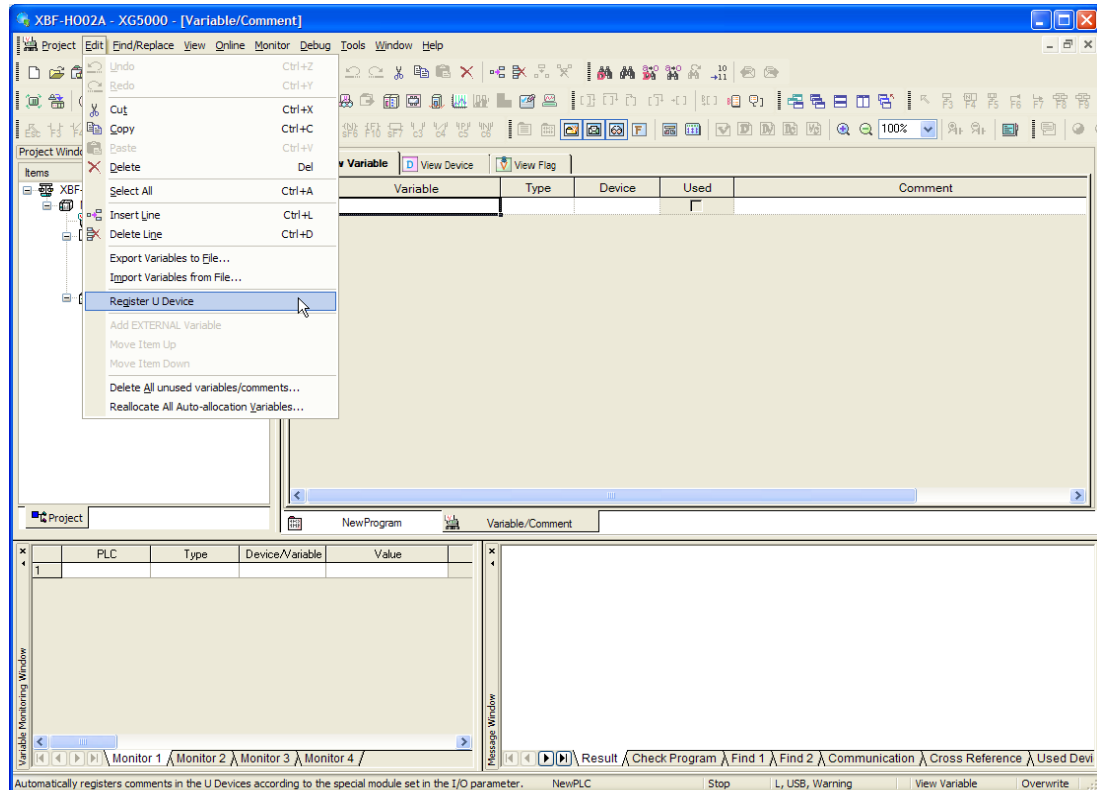

- 6) Click [Yes] to complete the U device registration that is set at [I/O parameter setting]

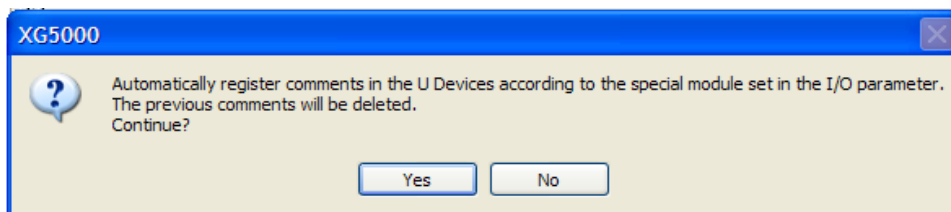

The screenshot displays the 'Variable/Comment' window in the XBF-H002A - XG5000 software. The window title is 'XBF-H002A - XG5000 - [Variable/Comment]'. The interface includes a menu bar (Project, Edit, Find/Replace, View, Online, Monitor, Debug, Tools, Window, Help), a toolbar, and a Project Window on the left showing a tree structure for 'NewPLC(XGB-XBCS)-Stop/Waming'. The main area contains a table with the following columns: Variable, Type, Device, Used, and Comment. The table lists 24 variables, all of type BIT, with their respective device addresses and comments. At the bottom, there is a 'Variable Monitor' section with a table and a 'Message Window'.

Variable	Type	Device	Used	Comment	
1	_02_CH0_DN	BIT	U02.00.0	<input type="checkbox"/>	HSC Module: CH0 Count Inc/Dec Flag
2	_02_CH0_EXTPRE	BIT	U02.00.1	<input type="checkbox"/>	HSC Module: CH0 External Preset Command Flag
3	_02_CH0_CRY	BIT	U02.00.3	<input type="checkbox"/>	HSC Module: CH0 Carry
4	_02_CH0_BRW	BIT	U02.00.4	<input type="checkbox"/>	HSC Module: CH0 Borrow
5	_02_CH0_AUXING	BIT	U02.00.5	<input type="checkbox"/>	HSC Module: CH0 Auxiliary Function Flag
6	_02_CH0_CMPOUT0	BIT	U02.00.6	<input type="checkbox"/>	HSC Module: CH0 Comparator Output0 Output
7	_02_CH0_CMPOUT1	BIT	U02.00.7	<input type="checkbox"/>	HSC Module: CH0 Comparator Output1 Output
8	_02_CH0_ERR	BIT	U02.00.E	<input type="checkbox"/>	HSC Module: CH0 Error Flag
9	_02_RDY	BIT	U02.00.F	<input type="checkbox"/>	HSC Module: Module Ready
10	_02_CH1_DN	BIT	U02.01.0	<input type="checkbox"/>	HSC Module: CH1 Count Inc/Dec Flag
11	_02_CH1_EXTPRE	BIT	U02.01.1	<input type="checkbox"/>	HSC Module: CH1 External Preset Command Flag
12	_02_CH1_CRY	BIT	U02.01.3	<input type="checkbox"/>	HSC Module: CH1 Carry
13	_02_CH1_BRW	BIT	U02.01.4	<input type="checkbox"/>	HSC Module: CH1 Borrow
14	_02_CH1_AUXING	BIT	U02.01.5	<input type="checkbox"/>	HSC Module: CH1 Auxiliary Function Flag
15	_02_CH1_CMPOUT0	BIT	U02.01.6	<input type="checkbox"/>	HSC Module: CH1 Comparator Output0 Output
16	_02_CH1_CMPOUT1	BIT	U02.01.7	<input type="checkbox"/>	HSC Module: CH1 Comparator Output1 Output
17	_02_CH1_ERR	BIT	U02.01.E	<input type="checkbox"/>	HSC Module: CH1 Error Flag
18	_02_CH0_CNTEN	BIT	U02.23.0	<input type="checkbox"/>	HSC Module: CH0 Counter Enable(Level) Command
19	_02_CH0_PREEN	BIT	U02.23.1	<input type="checkbox"/>	HSC Module: CH0 Preset Enable(Edge) Command
20	_02_CH0_DWNCNT	BIT	U02.23.2	<input type="checkbox"/>	HSC Module: CH0 Inc/Dec Count Setting(Level) Command
21	_02_CH0_AUXEN	BIT	U02.23.3	<input type="checkbox"/>	HSC Module: CH0 Auxiliary Function Enable(Edge,Level) Com
22	_02_CH0_CMPEN	BIT	U02.23.4	<input type="checkbox"/>	HSC Module: CH0 Count Comparison Function Enable(Level)
23	_02_CH0_OUTEN	BIT	U02.23.5	<input type="checkbox"/>	HSC Module: CH0 Comparator Output Enable(Level) Commar
24	_02_CH0_EQORST	BIT	U02.23.6	<input type="checkbox"/>	HSC Module: CH0 Comp-Output 0 EQUAL Reset(Edge) Comr

4.5 Registration of Special module variable

It is described to the method to register automatically variables[Global variables/Constants] of high speed counter module in XG5000 Project of XEC series.

4.5.1 Global/Direct Variables screen

If you double click [Global/direct Variables] of [Project Window], variables and comments which was registered already are displayed.

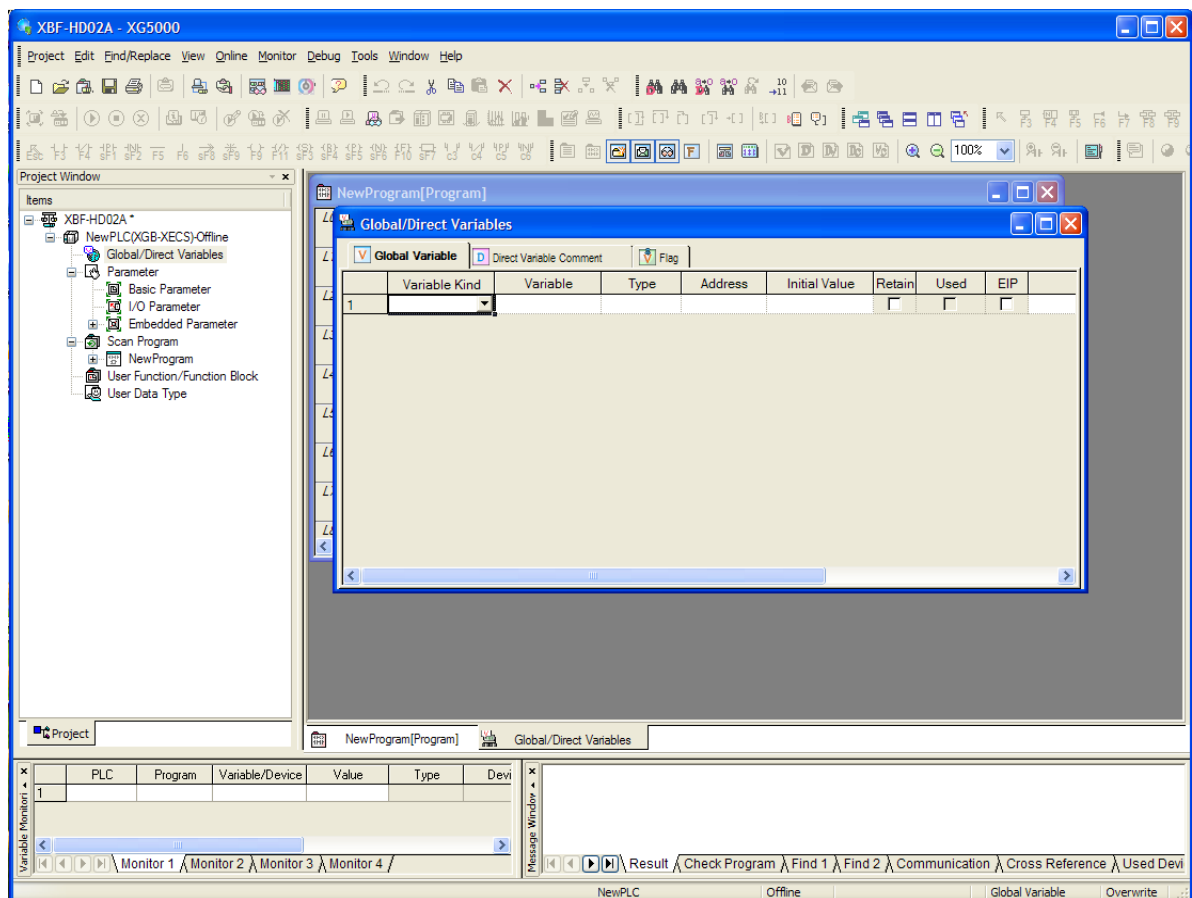

4.5.2 Registration of the special module variables

- 7) Select [Edit]→ [Register Special Module variables].
(First, [Global/Direct Variables] window has to be executed.)

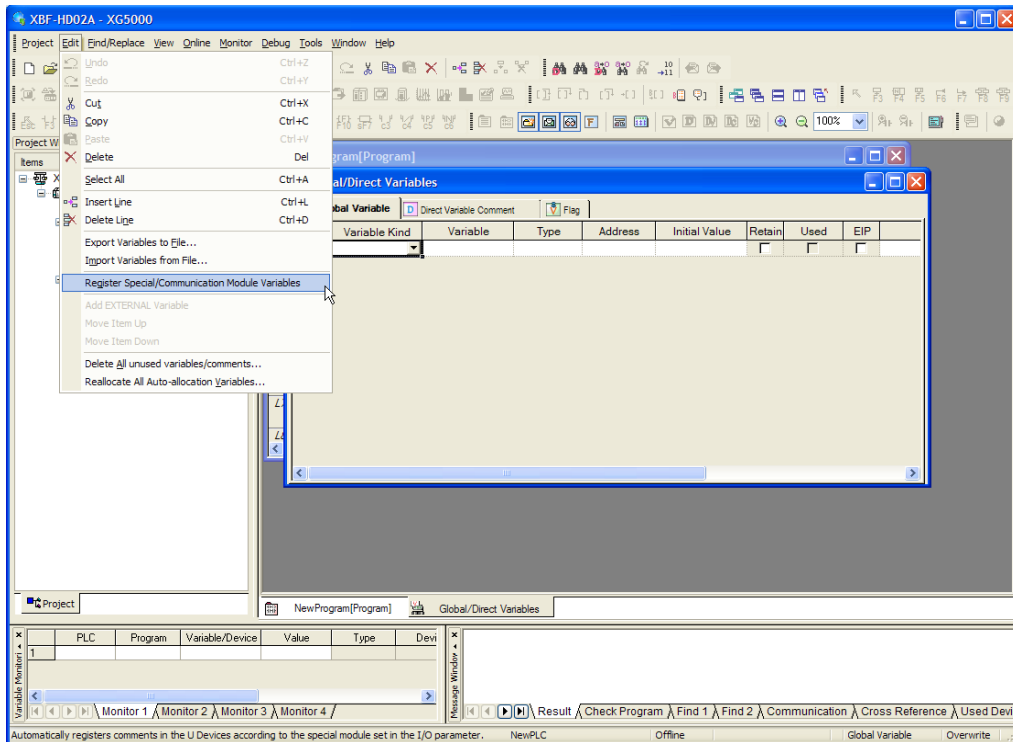

8) Click [Yes] to complete the special module variables registration that is set at [I/O parameter setting]

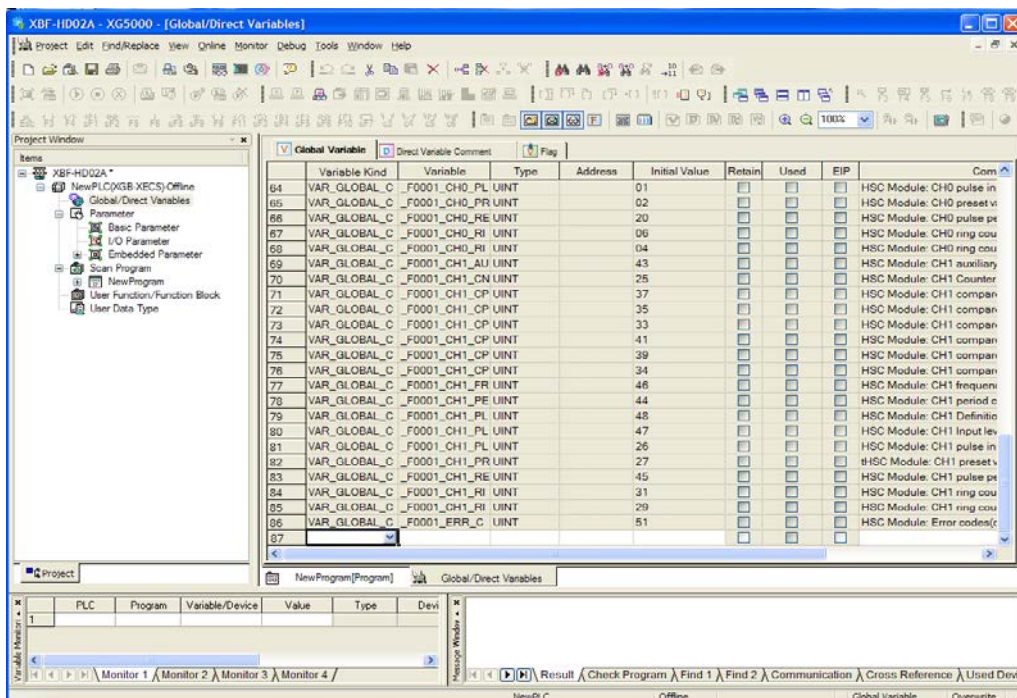
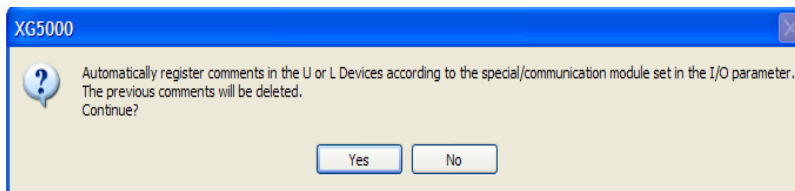

Chapter 5 Internal Memory & I/O Signals

5.1 Internal Memory

High Speed Counter has the internal memory used for data "Write/Read" to/from PLC CPU. The commands used for "Write" from PLC CPU to High Speed Counter's internal memory are PUT and PUTP, and the commands used for "Read" are GET and GETP. Configuration of the internal memory and the data is as described below.

5.1.1 Configuration of the internal memory

(1) Input setting area

Internal memory address		Details	Data setting range
Channel 0	Channel 1		
0	25	Select counter mode	0 ~ 1
1	26	Select pulse input mode	0 ~ 7
2	27	Set preset value	-2147483648~ 2147483648
3	28		
4	29	Minimum value of Ring count	-2147483648~ 2147483648
5	30		
6	31	Maximum value of Ring count	-2147483648~ 2147483648
7	32		
8	33	Select OUT 0 type	0 ~ 6
9	34	Select OUT 1 type	0 ~ 6
10	35	OUT0 compared based value (single-compared)/ minimum setting value (section compared)	-2147483648~ 2147483648
11	36		
12	37	OUT0 compared based value maximum setting value (section- compared)	-2147483648~ 2147483648
13	38		
14	39	OUT1 compared based value (single-compared)/ minimum setting value (section-compared)	-2147483648~ 2147483648
15	40		
16	41	OUT1 compared based value maximum setting value (section-compared)	-2147483648~ 2147483648
17	42		
18	43	Select auxiliary mode	0 ~ 6
19	44	Sampling count time setting or Revolution/Unit time setting	0 ~ 60000
20	45	Revolutions per hour function, pulses per revolution input	0 ~ 60000
21	46	Select frequency display mode	0 ~ 3
22	47	Select Low Active or High Active	0 ~ 1
23	48	Define output status when PLC CPU stops	0 ~ 1

(2) Output area of error code

Internal memory address		Details	Command
Channel 0	Channel 1		
51		Error code (channel 0, channel 1 common)	GET

5.1.2 Details & Data Configuration

(1) Count mode setting (CH0: 0 address, CH1: 25 address)

Setting value	Details
0	Linear count
1	Ring count

(2) Pulse input mode setting (CH0: 1 address, CH1: 26 address)

Setting value	Details
0	2-phase 1-multiplication
1	2-phase 2-multiplication
2	2-phase 4-multiplication
3	CW / CCW
4	1-phase, 1-input, 1-multiplication
5	1-phase, 1-input, 2-multiplication
6	1-phase, 2-input, 1-multiplication
7	1-phase, 2-input, 2-multiplication

(3) Comparison output types (CH0: 8, 9 address, CH1: 33, 34 address)

Setting value	Details
0	If present value < compared reference value, OUT□ is On
1	If present value =< compared reference value, OUT□ is On
2	If present value = compared reference value, OUT□ is On
3	If present value >= compared reference value, OUT□ is On
4	If present value > compared reference value, OUT□ is On
5	If compared minimum value =< present value =< compared maximum value, OUT□ is On
6	If compared minimum value >= present value, present value >= compared maximum value, OUT□ is On

※ Here, □ means 0 or 1.

(4) Auxiliary mode setting (CH0: 18 address, CH1: 43 address)

Setting value	Details
0	Auxiliary mode is not used
1	Count Clear
2	Count Latch
3	Sampling Count
4	Input Frequency Measure
5	Revolution/Unit time
6	Count Disable

(5) Frequency mode setting (CH0: 21 address, CH1: 46 address)

Setting value	Details
0	1 Hz unit displayed
1	10 Hz unit displayed
2	100 Hz unit displayed
3	1000 unit displayed (= 1kHz)

(6) Input pulse level setting (CH0: 22 address, CH1: 47 address)

Setting value	Details
0	Output disable
1	Output kept as it is

(7) Output status setting at PLC stop (CH0: 23 address, CH1 : 48 address)

Setting value	Details
0	Output disable
1	Output kept as it is

5.2 I/O Signals

(1) Input setting area

Channel 0	Channel 1	Details
Uxy.02 ~ Uxy.03	Uxy.12 ~ Uxy.13	Present count value
Uxy.04 ~ Uxy.05	Uxy.14 ~ Uxy.15	Latch count value
Uxy.06 ~ Uxy.07	Uxy.16 ~ Uxy.17	Sampling count value
Uxy.08 ~ Uxy.09	Uxy.18 ~ Uxy.19	Input frequency value
Uxy.10 ~ Uxy.11	Uxy.20 ~ Uxy.21	Revolutions per hour value

※ Here, 'xy' stands for the position High Speed Counter module is installed on. (xy => x:base no., y:slot no.)

(2) Operation status display and Operation command area

PLC <- High Speed Counter(Input)			PLC -> High Speed Counter(Output)	
CH	Signal	Details	Signal	Details
CH0	Uxy.00.0	Up/Down count status	Uxy.23.0	Count operation enable signal (Level)
	Uxy.00.1	External preset input flag	Uxy.23.1	Preset enable signal (edge)
	Uxy.00.2	-	Uxy.23.2	Up/Down count setting signal (Level)
	Uxy.00.3	Carry flag	Uxy.23.3	Auxiliary function use command(edge/ level)
	Uxy.00.4	Borrow flag	Uxy.23.4	Compared function use command(Level)
	Uxy.00.5	Flag during auxiliary mode	Uxy.23.5	Compared output external terminal enabled signal(Level)
	Uxy.00.6	OUT0 output signal	Uxy.23.6	OUT0 coincidence output reset signal (Edge)
	Uxy.00.7	OUT1 output signal	Uxy.23.7	OUT1 coincidence output reset signal (Edge)
	Uxy.00.8	-	Uxy.23.8	-
	Uxy.00.9	-	Uxy.23.9	-
	Uxy.00.A	-	Uxy.23.A	Carry/Borrow reset signal (Edge)
	Uxy.00.B	-	Uxy.23.B	Preset external input setting signal(Level)
	Uxy.00.C	-	Uxy.23.C	External auxiliary function selection (Level)
	Uxy.00.D	-	Uxy.23.D	External input preset flag reset signal(Edge)
	Uxy.00.E	Error flag	Uxy.23.E	-
	Uxy.00.F	Module Ready	Uxy.23.F	-
CH1	Uxy.01.0	Up/Down count status	Uxy.24.0	Count operation enable signal (Level)
	Uxy.01.1	External preset input flag	Uxy.24.1	Preset enable signal (edge)
	Uxy.01.2	-	Uxy.24.2	Up/Down count setting signal (Level)
	Uxy.01.3	Carry flag	Uxy.24.3	Auxiliary function use command (edge/ level)
	Uxy.01.4	Borrow flag	Uxy.24.4	Compared function use command (Level)
	Uxy.01.5	Flag during auxiliary mode	Uxy.24.5	Compared output external terminal enabled signal (Level)
	Uxy.01.6	OUT0 output signal	Uxy.24.6	OUT0 coincidence output reset signal (Edge)
	Uxy.01.7	OUT1 output signal	Uxy.24.7	OUT1 coincidence output reset signal (Edge)
	Uxy.01.8	-	Uxy.24.8	-
	Uxy.01.9	-	Uxy.24.9	-
	Uxy.01.A	-	Uxy.24.A	Carry/Borrow reset signal (Edge)
	Uxy.01.B	-	Uxy.24.B	Preset external input setting signal (Level)
	Uxy.01.C	-	Uxy.24.C	External auxiliary function selection (Level)
	Uxy.01.D	-	Uxy.24.D	External input preset flag reset signal(Edge)
	Uxy.01.E	Error flag	Uxy.24.E	-
	Uxy.01.F	-	Uxy.24.F	-

※Here, the size of Uxy.ab is 1 word and the size of Uxy.ab.i is 1 bit.

Chapter 6 Global Constant and Global Variable

It is described to global constant and global variable for XEC series.

Remark

It is terminology for XGB IEC type PLC series to Global constant(VAL_GLOBAL_CONST) and Global variable(VAL_GLOBAL). In XBM/XBC series, global constant is equivalent to the internal memory, global variable is to input/output signal(U device).

6.1 Global Constant

CPU module of XEC series are sharing the global constant area for the data transmission and receiving. It is PUT_### for the function block to transmit the data form XEC CPU module to the global constant area of the high speed counter module, the receiving function block is GET_###. About PUT_###, GET_### function block, please refer to the 'chapter 7 Programming'.

6.1.1 The configuration of Global Constant

1. Input data

Channel 0 Channel 1	Const Value	Contents	Data setting range
_Fxy_CH0_CNT_MODE _Fxy_CH1_CNT_MODE	00 25	Count types	0 or 1
_Fxy_CH0_PLS_MODE _Fxy_CH1_PLS_MODE	01 26	Pulse input types	0 ~ 7
_Fxy_CH0_PRESET _Fxy_CH1_PRESET	02 27	Preset value	-2147483648 ~ 2147483647
_Fxy_CH0_RING_MIN _Fxy_CH1_RING_MIN	04 29	Ring count minimum value	-2147483648 ~ 2147483647
_Fxy_CH0_RING_MAX _Fxy_CH1_RING_MAX	06 31	Ring count maximum value	-2147483648 ~ 2147483647
_Fxy_CH0_CP0_MODE _Fxy_CH1_CP0_MODE	08 33	Type of comparison output 0	0 ~ 6
_Fxy_CH0_CP1_MODE _Fxy_CH1_CP1_MODE	09 34	Type of comparison output 1	0 ~ 6
_Fxy_CH0_CP0_MIN _Fxy_CH1_CP0_MIN	10 35	Comparison reference value of comparison output 0(single comparison)/minimum value(section comparison)	-2147483648 ~ 2147483647
_Fxy_CH0_CP0_MAX _Fxy_CH1_CP0_MAX	12 37	Maximum value of comparison output 0 (section comparison)	-2147483648 ~ 2147483647
_Fxy_CH0_CP1_MIN _Fxy_CH1_CP1_MIN	14 39	Comparison reference value of comparison output 1(single comparison)/minimum value(section comparison)	-2147483648 ~ 2147483647
_Fxy_CH0_CP1_MAX _Fxy_CH1_CP1_MAX	16 41	Maximum value of comparison output 1 (section comparison)	-2147483648 ~ 2147483647
_Fxy_CH0_AUX_MODE _Fxy_CH1_AUX_MODE	18 43	Type of additional function	0 ~ 6
_Fxy_CH0_PERIOD _Fxy_CH1_PERIOD	19 44	Setting time of sampling count or of setting time "revolution per unit time"	0 ~ 60000
_Fxy_CH0_REV_UNIT _Fxy_CH1_REV_UNIT	20 45	Pulse per 1 rotation of "revolution per unit time"	0 ~ 60000
_Fxy_CH0_FREQ_MODE _Fxy_CH1_FREQ_MODE	21 46	Frequency display unit of "input frequency measure"	0 ~ 3
_Fxy_CH0_PLS_LVL _Fxy_CH1_PLS_LVL	22 47	Select Low Active or High Active	0 ~ 1
_Fxy_CH0_PLCSTOP_OUT_EN _Fxy_CH1_PLCSTOP_OUT_EN	23 48	Define output status when PLC CPU stops	0 ~ 1

Remark
(1) 'Fxy' : 'x' means the base number of the high speed counter module, 'y' means the slot number of it.
(2) Constant value can not be modified, because it is the address of input data area.
(3) Constant value is the same as the internal memory address of XBM/XBC series.

2. Output area of the error code

Channel 0 Channel 1	Constant value	Contents	Function Block
_Fxy_ERR_CODE	51	Error code (channel 0, channel 1 common)	GET_###

6.1.2 The Configuration and Contents of Data

1. Count types (channel 0: _Fxy_CH0_CNT_MODE, channel 1: _Fxy_CH1_CNT_MODE)

Setting value	Contents
0	Linear count
1	Ring count

2. Pulse input types (channel 0: _Fxy_CH0_PLS_MODE, channel 1: _Fxy_CH1_PLS_MODE)

Setting value	Contents
0	2 phase 1 multiplier
1	2 phase 2 multiplier
2	2 phase 4 multiplier
3	CW/CCW
4	1 phase /1 input /1 multiplier
5	1 phase /1 input /2 multiplier
6	1 phase /2 input /1 multiplier
7	1 phase /2 input /2 multiplier

3. Comparison output types (channel 0: _Fxy_CH0_CP□_MODE, channel 1: _Fxy_CH1_CP□_MODE)

Setting value	Contents
0	In case of current count value < comparison reference value, OUT□ is On
1	In case of current count value ≤ comparison reference value, OUT□ is On
2	In case of current count value = comparison reference value, OUT□ is On
3	In case of current count value ≥ comparison reference value, OUT□ is On
4	In case of current count value > comparison reference value, OUT□ is On
5	In case of comparison minimum value ≤ current count value ≤ comparison maximum value, OUT□ is On
6	In case of comparison minimum value ≥ current count value, current count value ≤ comparison maximum value, OUT□ is On

※ Here, □ means 0 or 1.

4. Additional function types (channel 0: _Fxy_CH0_AUX_MODE, channel 1: _Fxy_CH1_AUX_MODE)

Setting value	Contents
0	Not used
1	Count clear
2	Count latch
3	Sampling count
4	Input frequency measure
5	Revolution measure per unit time
6	Count disable

5. The frequency display unit of input frequency measure
(channel 0: `_Fxy_CH0_FREQ_MODE`, channel 1: `_Fxy_CH1_FREQ_MODE`)

Setting value	Contents
0	1Hz
1	10Hz
2	100Hz
3	1000Hz(=1kHz)

6. Setting area of comparison output status

Constant value	Contents	Default
0	Low Active	Low Active
1	High Active	

7. When XGB CPU module is STOP mode, comparison output status
(channel 0: `_Fxy_CH0_PLCSTOP_OUT_EN`, channel 1: `_Fxy_CH1_PLCSTOP_OUT_EN`)

Constant value	Contents
0	Output disable
1	Ouput preservation

6.2 Global Variable

1. The range of output data

Channel 0	Channel 1	Contents
_xy_CH0_CNT	_xy_CH1_CNT	Current count value
_xy_CH0_FRQ	_xy_CH1_FRQ	Count latch
_xy_CH0_LTH	_xy_CH1_LTH	Sampling count
_xy_CH0_RNG	_xy_CH1_RNG	Input frequency count
_xy_CH0_RPU	_xy_CH1_RPU	Revolution per unit time

Remark

- (1) Here, 'x' means the base number which the high speed counter module is mounted, and 'y' means the slot number of it.
- (2) It is double word (dword) to the data type of the range of output data.

2. The display of operation status and the range of operation command

Channel	Output (CPU Module ← High speed counter)		Input (CPU Module → High speed counter)	
	Status	Contents	Command	Contents
Channel0	_xy_CH0_DN	Count Up/Down status	_xy_CH0_CNTEN	Count enable (level)
	_xy_CH0_EXTPRE	Input detection of external preset	_xy_CH0_PREEN	Preset enable (edge)
	_xy_CH0_CRY	Carry detection	_xy_CH0_DWNCNT	Up/Down count selection (level)
	_xy_CH0_BRW	Borrow detection	_xy_CH0_AUXEN	Additional function enable(level/edge)
	_xy_CH0_AUXING	In operation of additional function	_xy_CH0_CMPEN	Comparison enable (level)
	_xy_CH0_CMPOUT0	The status of comparison output 0	_xy_CH0_OUTEN	Comparison output enable (level)
	_xy_CH0_CMPOUT1	The status of comparison output 1	_xy_CH0_EQ0RST	Equal (=) reset of comparison output 0 (edge)
	_xy_CH0_ERR	Error detection	_xy_CH0_EQ1RST	Equal (=) reset of comparison output 1 (edge)
	_xy_RDY	Module ready	_xy_CH0_CRTBRW_RST	Carry/Borrow reset (edge)
	-	-	_xy_CH0_EXTPST_EN	External preset selection (edge)
	-	-	_xy_CH0_EXTAUX_EN	Selection of external additional function (edge)
-	-	_xy_CH0_EXTPST_RST	Detection reset of external preset(edge)	
Channel1	_xy_CH1_DN	Count Up/Down status	_xy_CH1_CNTEN	Count enable (level)
	_xy_CH1_EXTPRE	Input detection of external preset	_xy_CH1_PREEN	Preset enable (edge)
	_xy_CH1_CRY	Carry detection	_xy_CH1_DWNCNT	Up/Down count selection (level)
	_xy_CH1_BRW	Borrow detection	_xy_CH1_AUXEN	Additional function enable(level/edge)
	_xy_CH1_AUXING	In operation of additional function	_xy_CH1_CMPEN	Comparison enable (level)
	_xy_CH1_CMPOUT0	The status of comparison output 0	_xy_CH1_OUTEN	Comparison output enable (level)
	_xy_CH1_CMPOUT1	The status of comparison output 1	_xy_CH1_EQ0RST	Equal (=) reset of comparison output 0 (edge)
	_xy_CH1_ERR	Error detection	_xy_CH1_EQ1RST	Equal (=) reset of comparison output 1 (edge)
	-	-	_xy_CH1_CRTBRW_RST	Carry/Borrow reset (edge)
	-	-	_xy_CH1_EXTPST_EN	External preset selection (edge)
	-	-	_xy_CH1_EXTAUX_EN	Selection of external additional function (edge)
-	-	_xy_CH1_EXTPST_RST	Detection reset of external preset(edge)	

Remark

It is bool type to the data type of the display of operation status and the range of operation command.

Chapter 7 Programming

Here describes how to program by using instruction (XBM/XBC series) or function block (XEC) at scan program of XG5000

7.1 Instruction and Function Block

Here describes instruction and function block to read and write data of HSC module at XGB CPU module.

Remark

There is difference on terminology used in XBM/XBC series and XEC series. The following table indicates the relation of terminology used in HSC module.



XBM/XBC series	XEC series
Instruction	Function Block
Internal memory	Global constant
I/O signal (U device)	Global variable
Device	Variable
F area	Flag

7.1.1 Instruction of XBM/XBC series

1. GET/GETP instruction

It is an instruction used to read the details of High Speed counter module's internal memory to PLC CPU. The read data can be saved on PLC CPU memory (except F area).

(1) Operation of GET/GETP instruction

GET	Always executed with execution condition On ()	Level
GETP	Executed with execution condition of operation start ()	Edge

(2) Configuration of GET/GETP Instruction

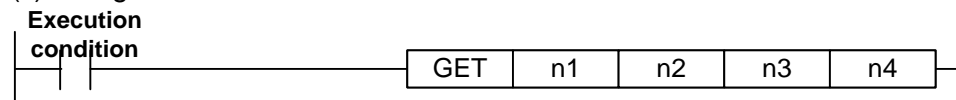

Type	Description	Area Available	Type
n1	Slot No. the special module is installed on	Integer	Hexadecimal is recommended
n2	Start address of special module's operation parameters setting area to read data	Integer	
n3	Device's start address with saved data to read	M, P, K, L, T, C, D, #D	
n4	Number of words data to read	Integer	

(a) How to set base and slot number

1) Basic base

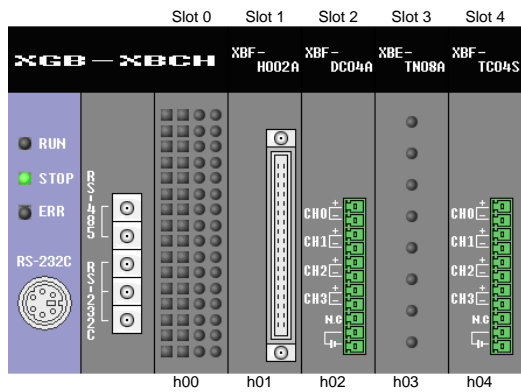

(3) Use of GET/GETP instruction

(a) HSC module is installed at slot 8 of basic base and While M00000 is On, it transmits the data (data1, data2) of internal memory 5 and 6 to D00015 and D00016.

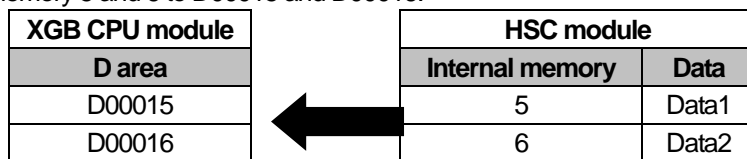

(b) It transmits data at rising edge of M00000.



(c) HSC module is installed at slot 4 of extension base stage 2. While M00001 is on, it transmits data of internal memory 10 ~ 15 to D00001 ~ D00006.

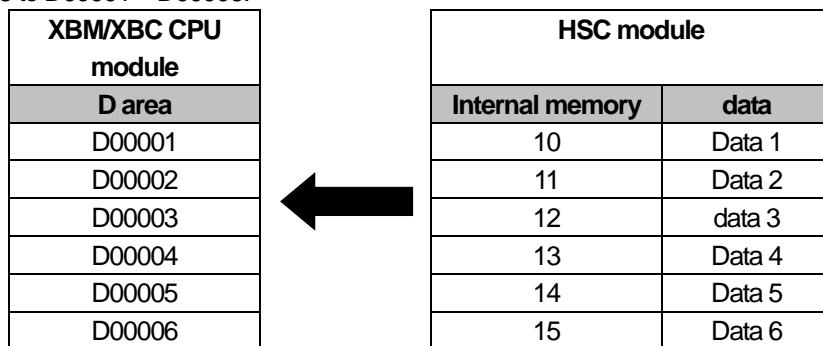

2. PUT/PUTP instruction

Instruction to write data from XGB CPU module to internal memory area

(1) PUT/PUTP instruction

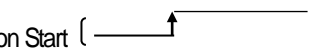
PUT	Always executed with execution condition On ()	Level
PUTP	Executed with execution condition of operation Start ()	Edge

(2) Configuration of PUT/PUTP instruction

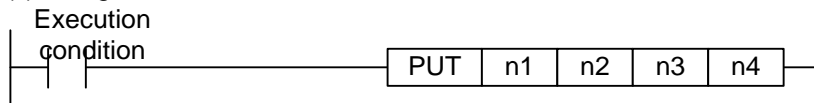

Type	Description	Available area	Reference
n1	Slot No. the special module is installed on	Integer	Hexadecimal is recommended
n2	Start address of special module's internal memory to write data.	Integer	
n3	Device's start address or integer with saved data to write.	M, P, K, L, T, C, D, #D	
n4	Number of words data to write	Integer	

(a) Base and slot number setting method

It is same with GET/GETP instruction

(3) Use of PUT/PUTP instruction

(a) HSC module is equipped at 1 slot of basic base. While M0000 is On, it transmits data of D00000 (data1) to internal memory address 1

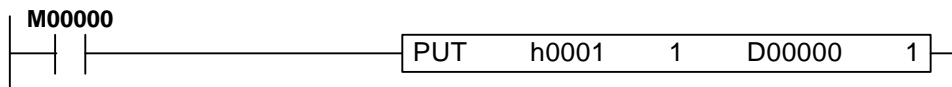
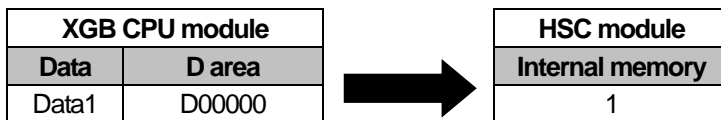

(b) It transmits data at the rising edge of M0000

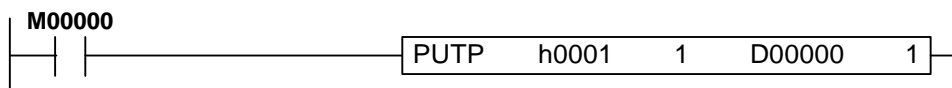

7.1.2 Function Block of XEC

1. GET function block

Function Block to read data of Global constant area at XEC CPU module. That data can be saved at variable area of XEC CPU module (Except flag area).

(1) GET function block configuration

Function block		Classification	Variable	Description
	Input	REQ	Request execution	
		BASE	Base where HSC module is equipped	
		SLOT	Slot where HSC module is equipped	
		MADDR	Global constant area	
	Output	DONE	Function Block execution status	
		STAT	Error information	
		DATA	Output data	

Remark

- (1) '###' means that WORD, DWORD, INT, UINT, DINT, UDINT type is available.
- (2) For 'REQ', edge signal or level signal is available.
- (3) For 'MADDR', Global constant or integer is available.
- (4) 'Output data' is data read from Global constant.
- (5) In case of XGR, HSC module should be equipped at extension base.

Function block is classified as follows according to output variable type.

Function Block	Output variable type	Operation description
GET_WORD	WORD	Reads WORD data from Global constant area (MADDR).
GET_DWORD	DWORD	Reads DWORD data from Global constant area (MADDR).
GET_INT	INT	Reads INT data from Global constant area (MADDR).
GET_UINT	UINT	Reads UINT data from Global constant area (MADDR).
GET_DINT	DINT	Reads DINT data from Global constant area (MADDR).
GET_UDINT	UDINT	Reads UDINT data from Global constant area (MADDR).

(2) Use of GET function block

(a) HSC module is equipped at slot 8 of basic base. While 'Read1' is on, it transmits data of '_F01_CH0_CNT_MODE' to 'Output data1'

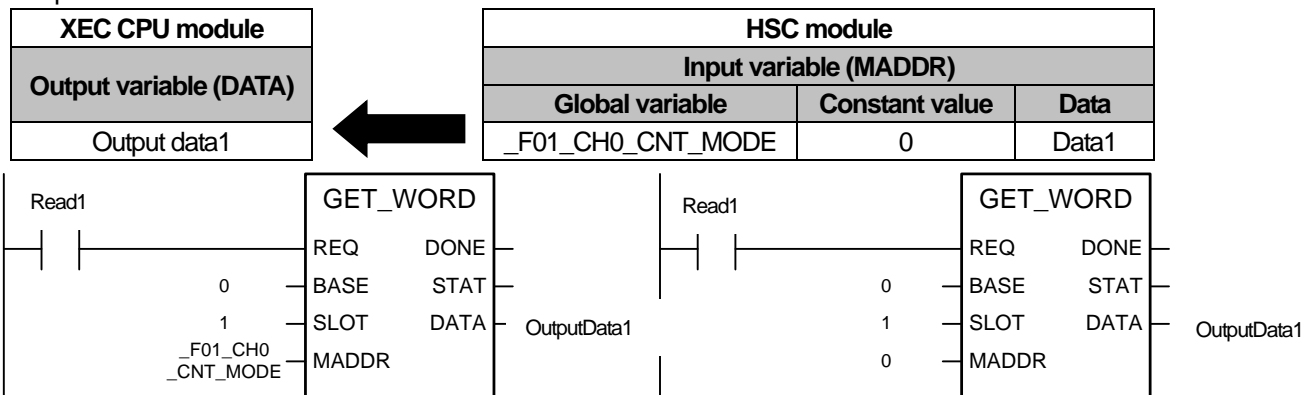

Remark

- (1) Results of above two examples are same.
- (2) For detail of Global variable, refer to XG5000 user manual.

(b) It transmits data at the rising edge of execution condition

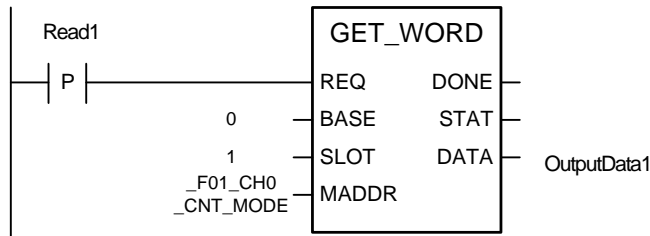

2. PUT function block

Function Block to write the data into Global constant area at XEC CPU module.

(1) Configuration of PUT function block

Function Block		classification	Variable	Description
	Input	REQ	Request execution	
		BASE	Base where HSC module is equipped	
		SLOT	Slot where HSC module is equipped	
		MADDR	Global constant area	
		DATA	Input data	
		Output	DONE	Function block execution status
			STAT	Error information

Remark

- (1) '###' means that WORD, DWORD, INT, UINT, DINT, UDINT type is available.
- (2) For 'REQ', edge signal or level signal is available.
- (3) For 'MADDR', Global constant or integer is available.
- (4) 'Output data' is data read from Global constant.
- (5) In case of XGR, HSC module should be equipped at extension base.

Function block is classified as follows according to output variable type.

Function block	Input variable type	Operation description
PUT_WORD	WORD	Writes WORD data to Global constant area (MADDR).
PUT_DWORD	DWORD	Writes DWORD data to Global constant area (MADDR).
PUT_INT	INT	Writes INT data to Global constant area (MADDR).
PUT_UINT	UINT	Writes UINT data to Global constant area (MADDR).
PUT_DINT	DINT	Writes DINT data to Global constant area (MADDR).
PUT_UDINT	UDINT	Writes UDINT data to Global constant area (MADDR).

(2) Use of PUT function block

(a) HSC module is equipped at slot 10 of basic base. While 'Write1' is on, it transmits data (Data1) of 'InputData1' to '_F0A_CH0_CNT_MODE'.

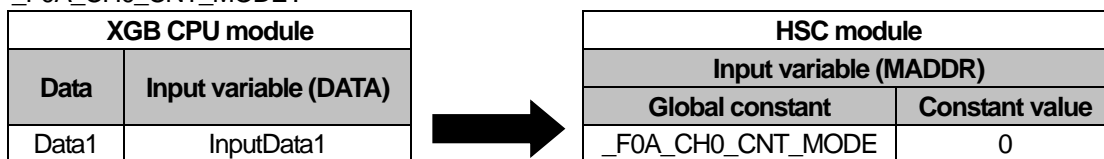

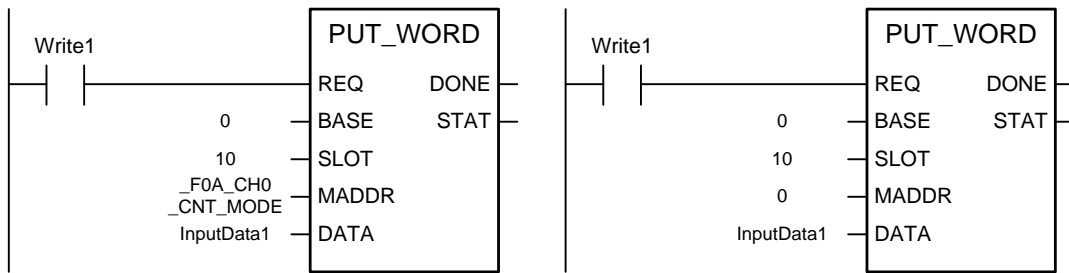

Remark

(1) Operations of above two examples are same.
 (2) For detail of Global variable, refer to 'XG5000 user manual'.

(b) It transmits data at the rising edge of execution condition

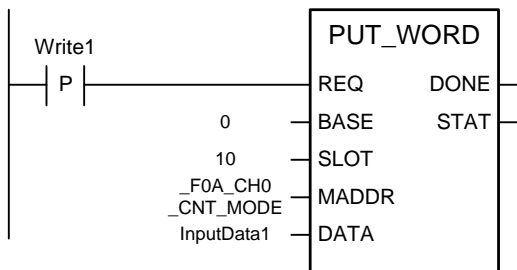

7.2 Program

1. XGB system is explained referring to the following system HSC module is equipped at slot 1 of basic base.

7.2.1 Count mode setting

Example explaining how to set Ring Count Min. and Max. As for setting method by 'I/O Parameter', refer to Chapter 4.

1. Setting content

Parameter	CH0	CH1
Count mode	1: Ring counter	1: Ring counter
Ring counter min.	0	0
Ring counter max.	100000	100000

2. Program

(1) Scan program of XBM/XBC series

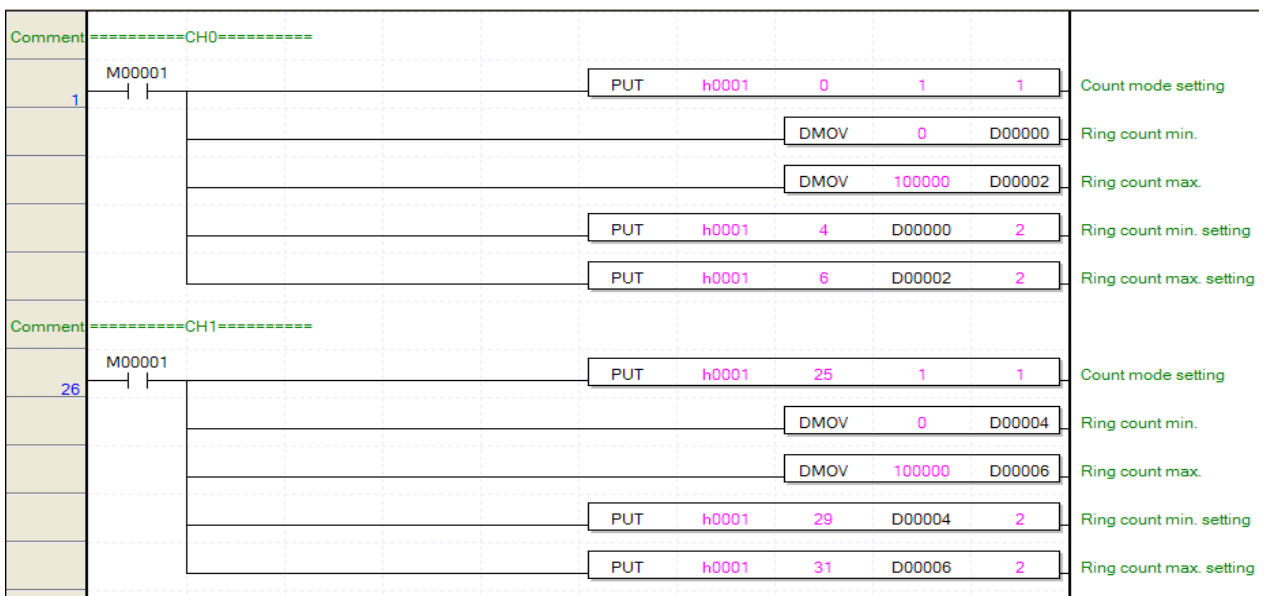

(2) Scan program of XECseries.

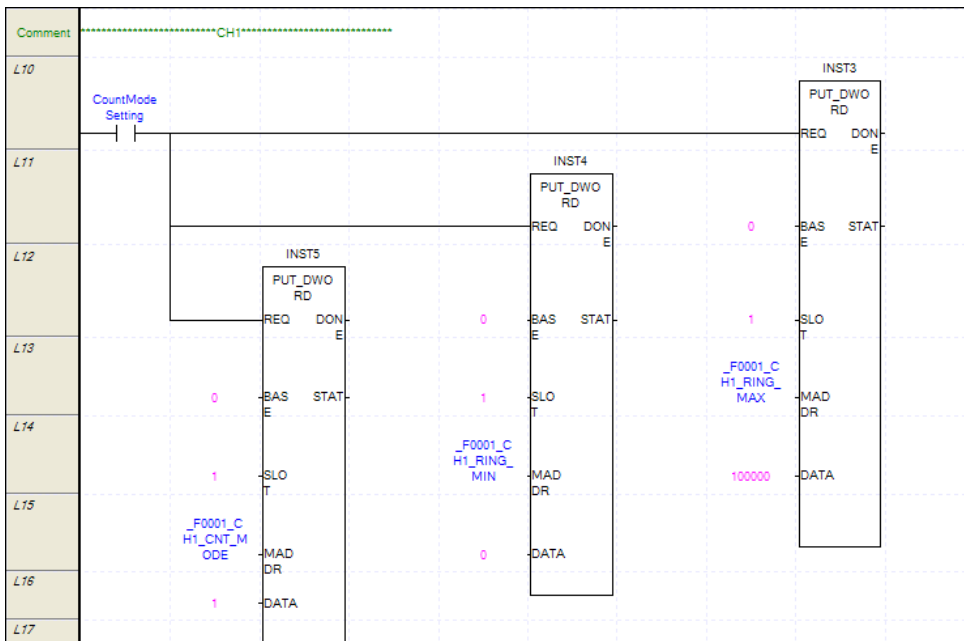
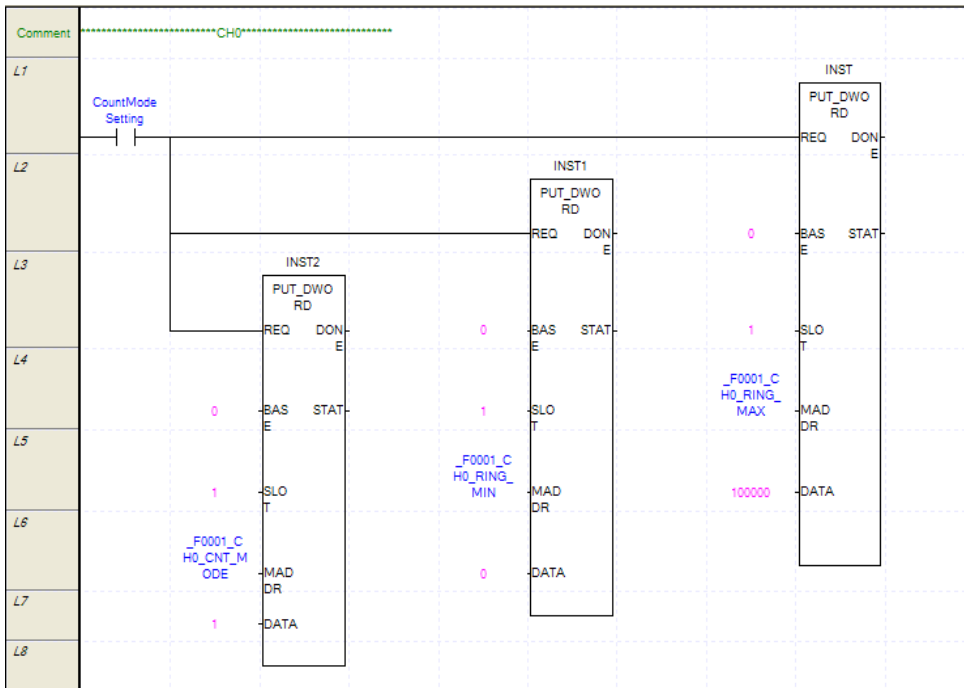

Remark

- (1) Since instruction PUT (Function Block PUT_DWORD) is used at scan program example of XBM/XBC (XEC) series, while input contact point is On, data is transmitted into HSC module. So, if data is changed, it is transmitted into HSC module automatically.
- (2) If you program as follows, its operation become different with program example.

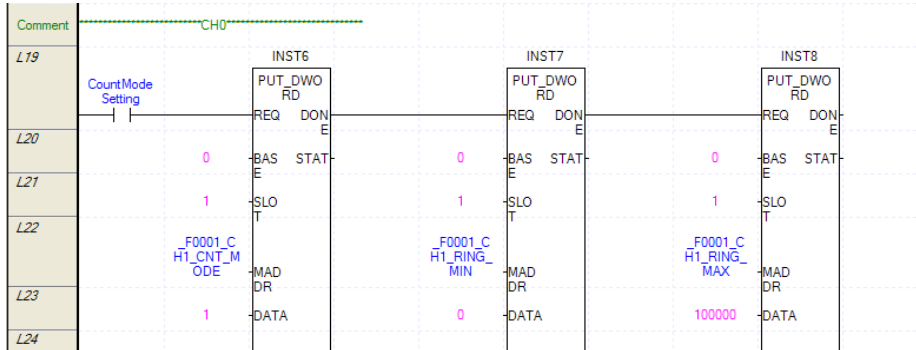

- (a) If input contact point of function block is on and execution of function block is complete, 'DONE' becomes 1. Namely, front function block and back function block are not executed simultaneously and from left to right, they are executed sequentially.
- (b) If input variable of function block is set incorrectly and an error occurs, 'DONE' doesn't become 1. Namely, if an error occurs at the front function block, the back function block is not executed.
- (3) Integer can be inserted into 'MADDR' instead of a global constant. The operation of the following program is the same as that of the front example.

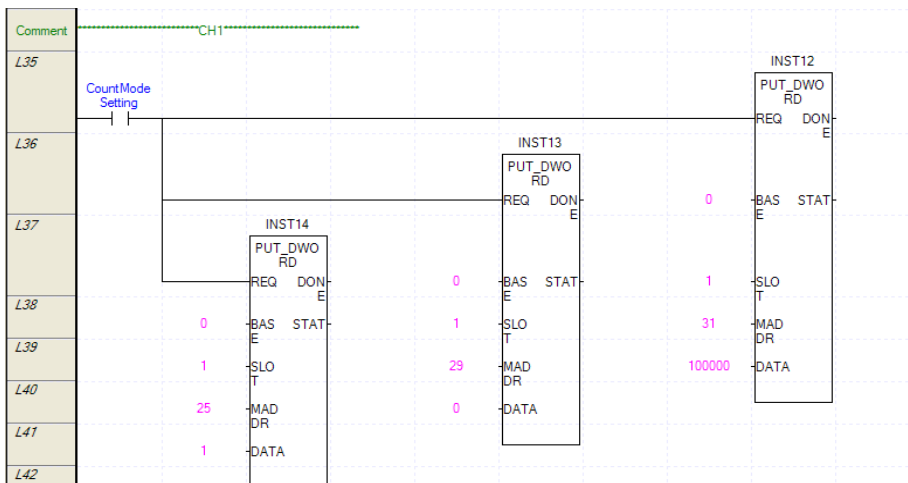
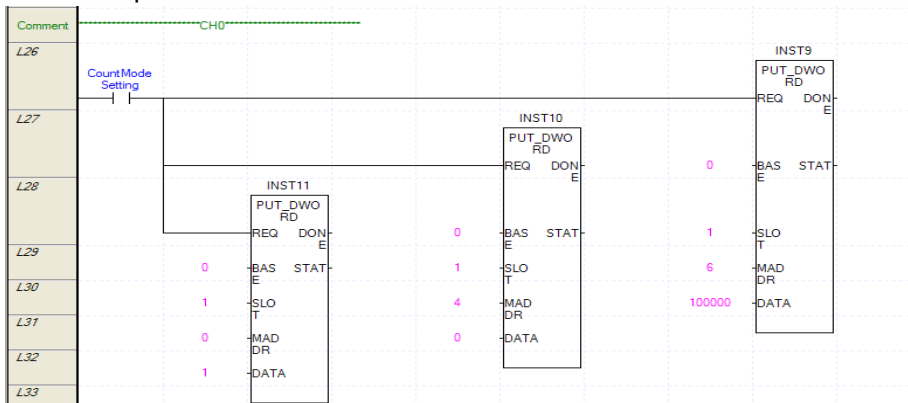

- (a) For integer corresponding to global constant, refer to Chapter 6.
- (b) On the next program example, the scan program example using integer (constant) is omitted.

7.2.2 Pulse input mode setting

Program example setting pulse input mode

1. Setting contents

Parameter	CH0	CH1
Pulse input mode	3: CW/CCW	3: CW/CCW

2. Program

(1) Scan program of XBM/XBC series

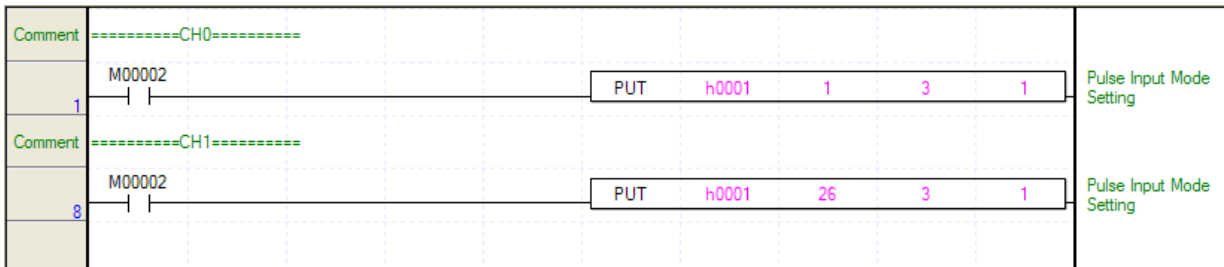

(2) Scan program of XECseries

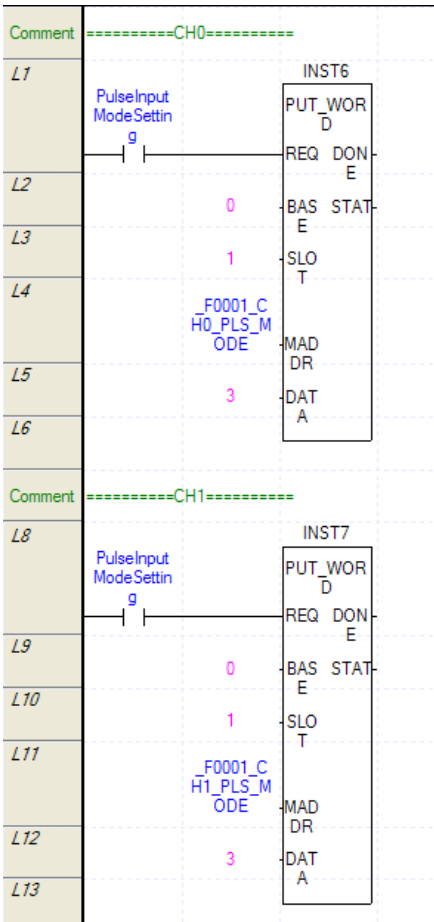

7.2.3 Counter check

Program example checking current counter and operation by auxiliary function.

1. Program

(1) Scan program of XBM/XBC series

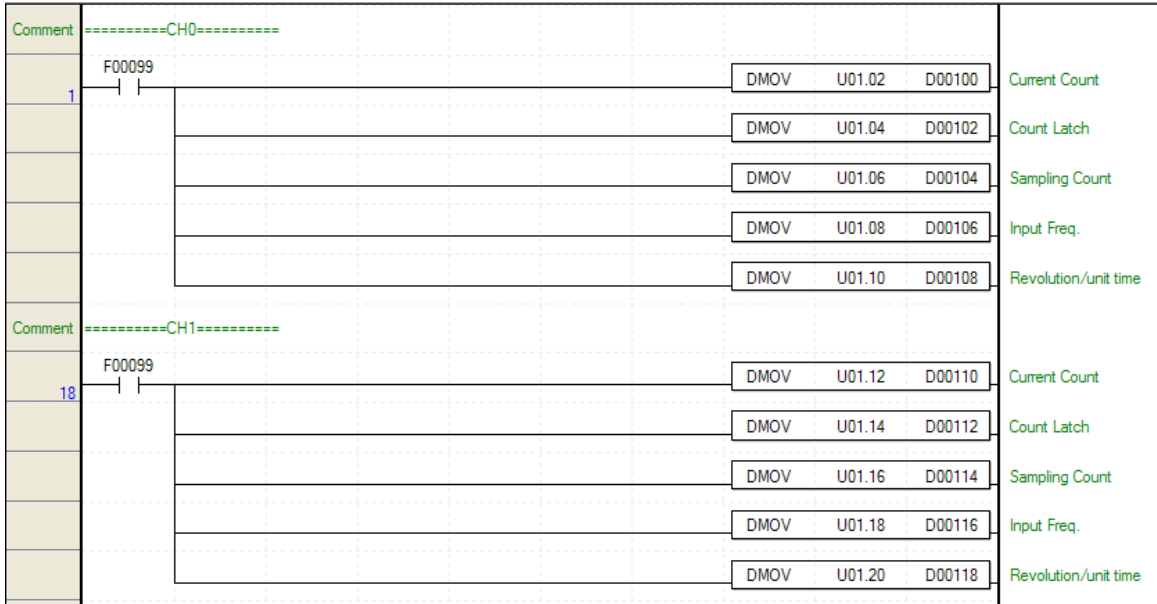

(2) Scan program of XECseries

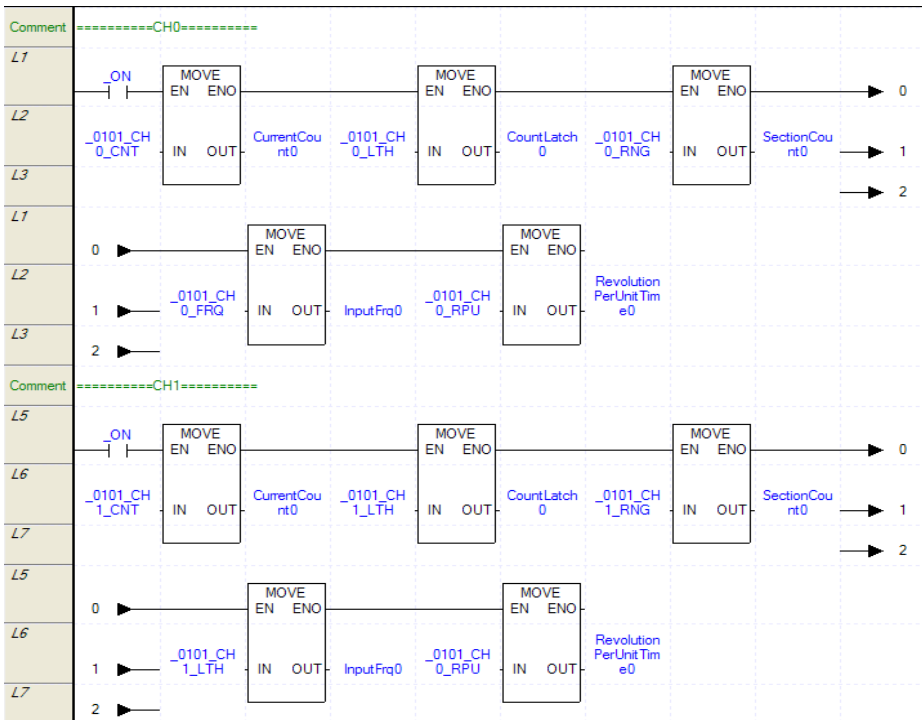

Remark

In Scan program of XGI/XGR, the number of cell is changed by using icon  or 'Change Columns' of 'View'

7.2.4 Preset value setting and enable preset

Program example about how to set preset value and enable preset

1. Setting content

Parameter	CH0	CH1
Preset value	1000	1000

2. Program

(1) Scan program of XBM/XBC series

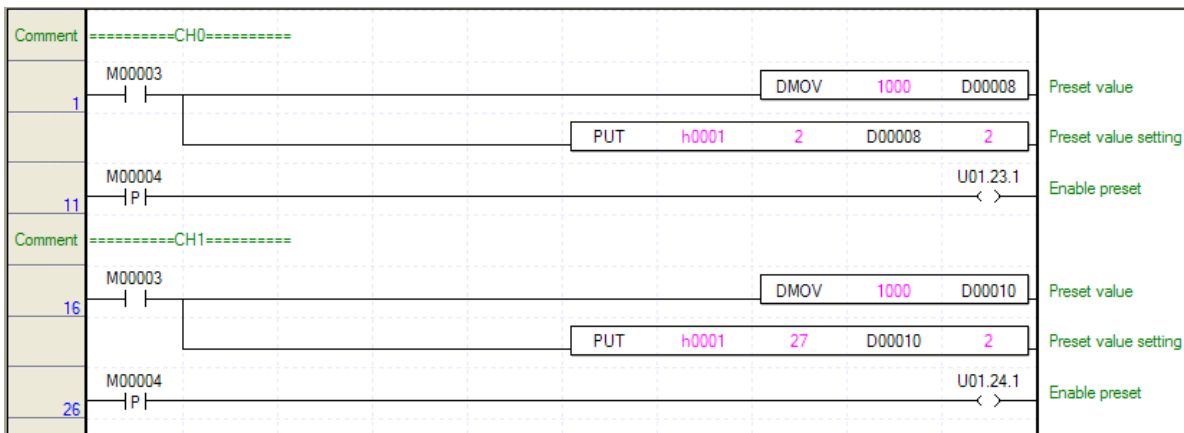

(2) Scan program of XEC

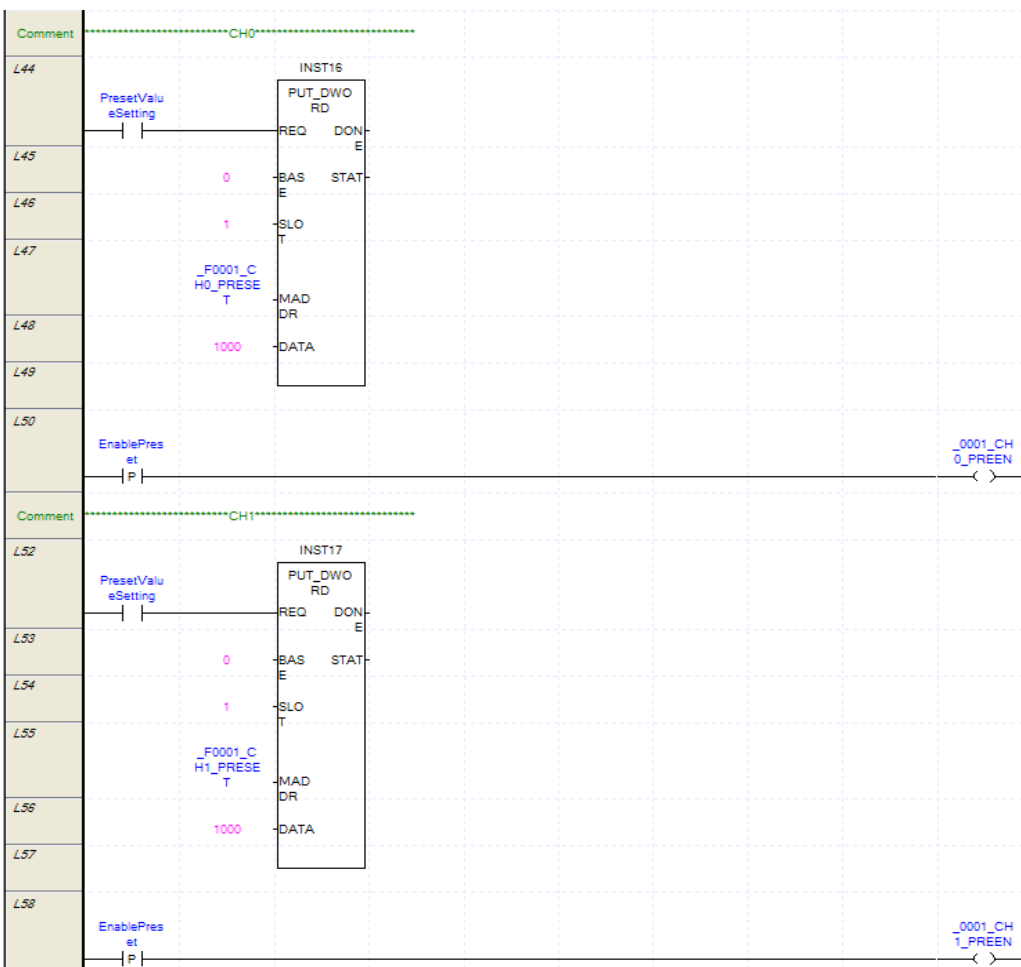

7.2.5 Enable counter

Program example executing Enable counter

1. Program

(1) Scan program of XBM/XBC series

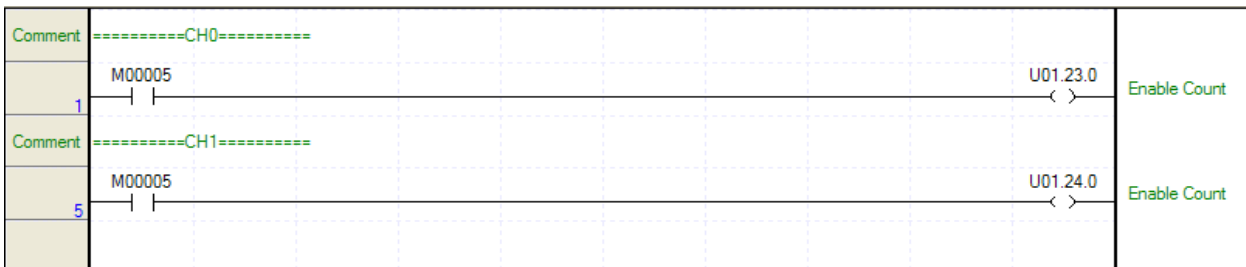

(2) Scan program of XECseries

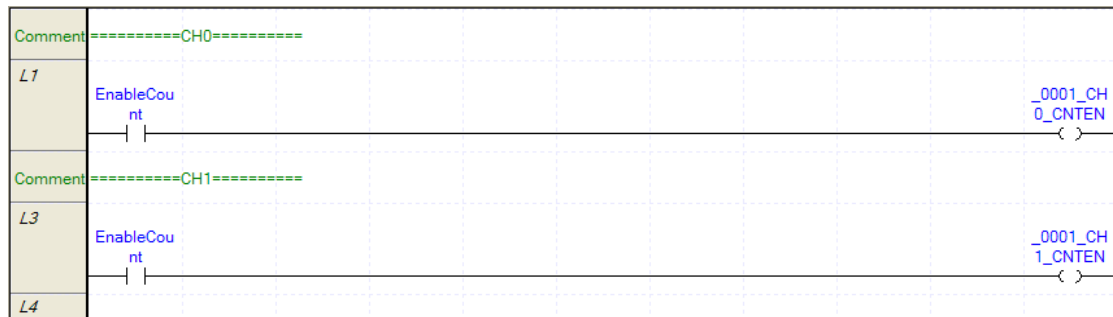

7.2.6 Carry/borrow detection reset

Program example resetting the detected carry/borrow signal

1. Program

(1) Scan program of XBM/XBC series

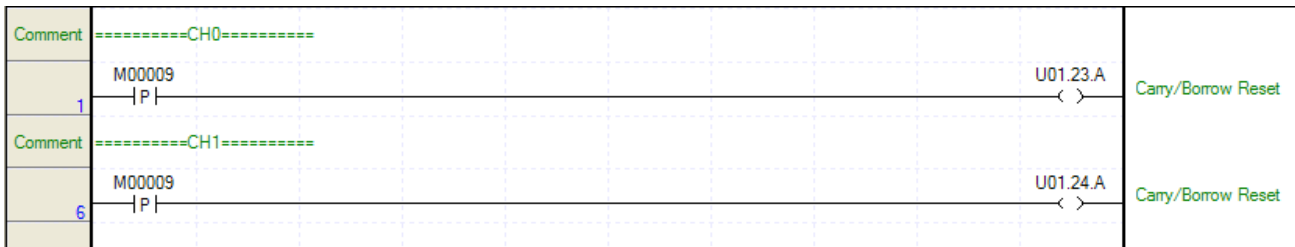

(2) Scan program of XECseries

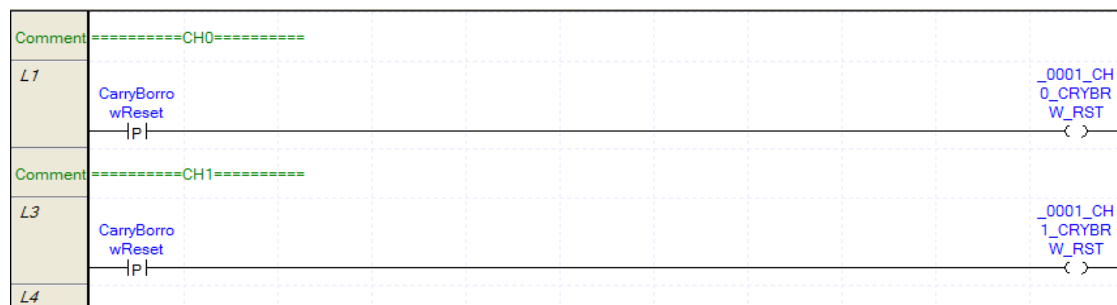

7.2.7 Auxiliary mode setting and Enable auxiliary function

Program example setting auxiliary mode and executing Enable auxiliary function. You can check the operation result of auxiliary function at 7.2.3 Counter check.

1. Counter Clear

When auxiliary function is on, change current counter as 0.

(1) Setting contents

Parameter	CH0	CH1
Auxiliary mode	1: Counter Clear	1: Counter Clear

(2) Program

(a) Scan program of XBM/XBC series

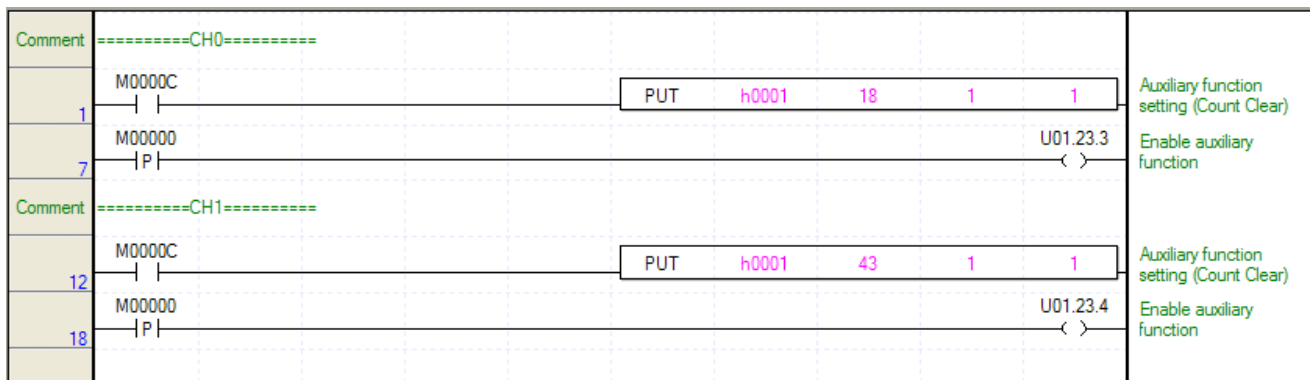

(b) Scan program of XEC



2. Counter latch

When Enable auxiliary is on, it indicates current counter at counter latch.

(1) Setting contents

Parameter	CH0	CH1
Auxiliary mode	2: Counter latch	2: Counter latch

(2) Program

(a) Scan program of XBM/XBC series

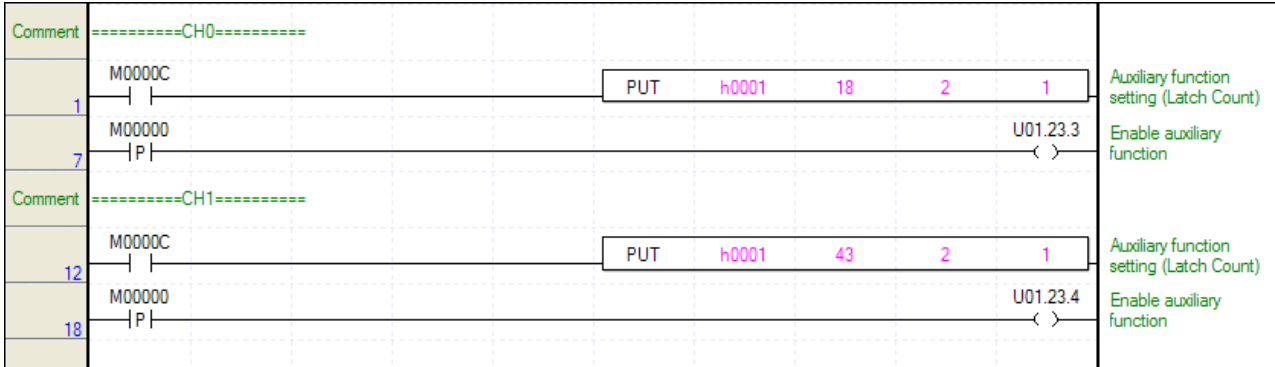

(b) Scan program of XECseries

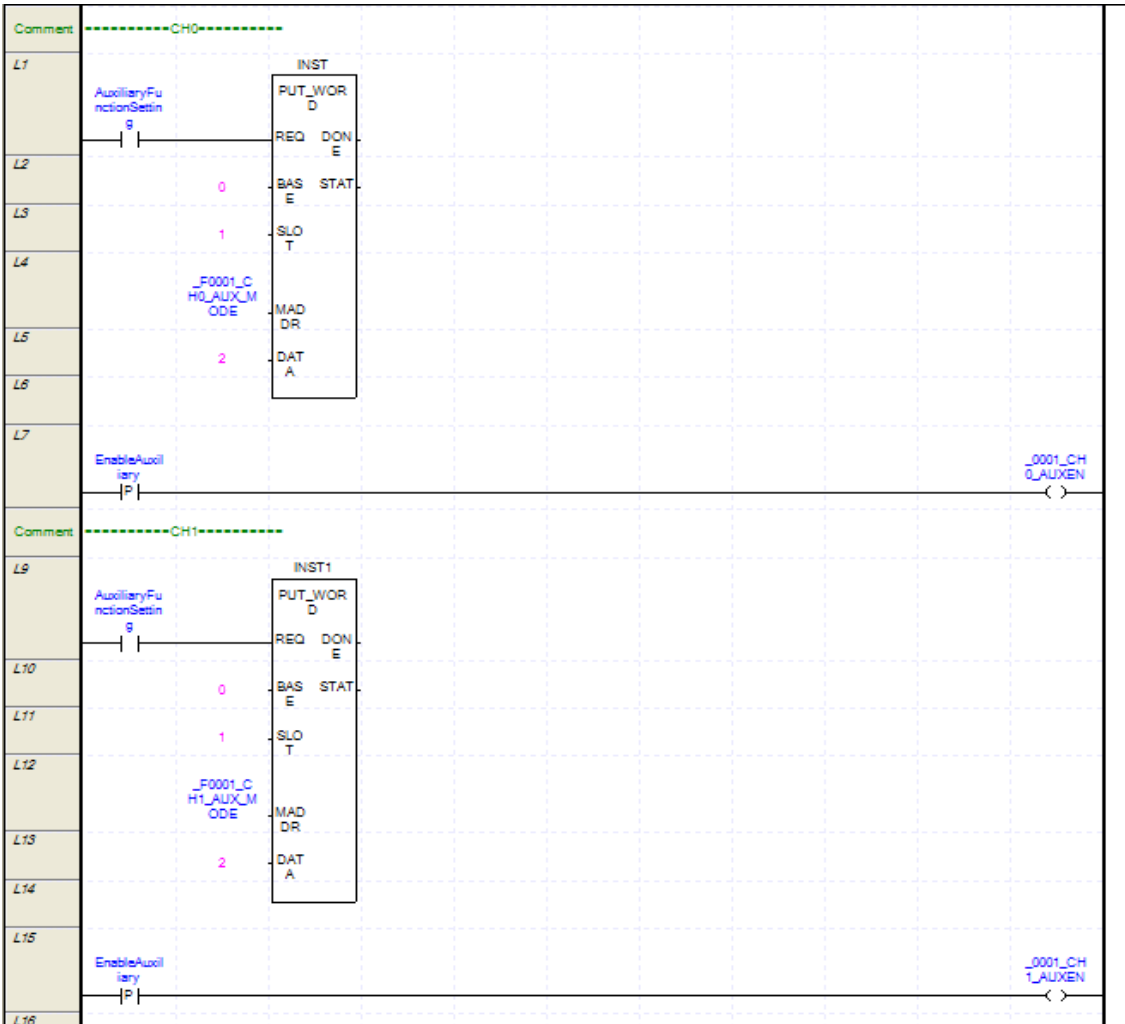

3. Sampling Count

Counter from when Enable auxiliary is on to setting time is indicated at sampling counter.

(1) Setting content

Parameter	CH0	CH1
Auxiliary mode	3: Sampling Count	3: Sampling Count
Range value	5000	5000

(2) Program

(a) Scan program of XBM/XBC series

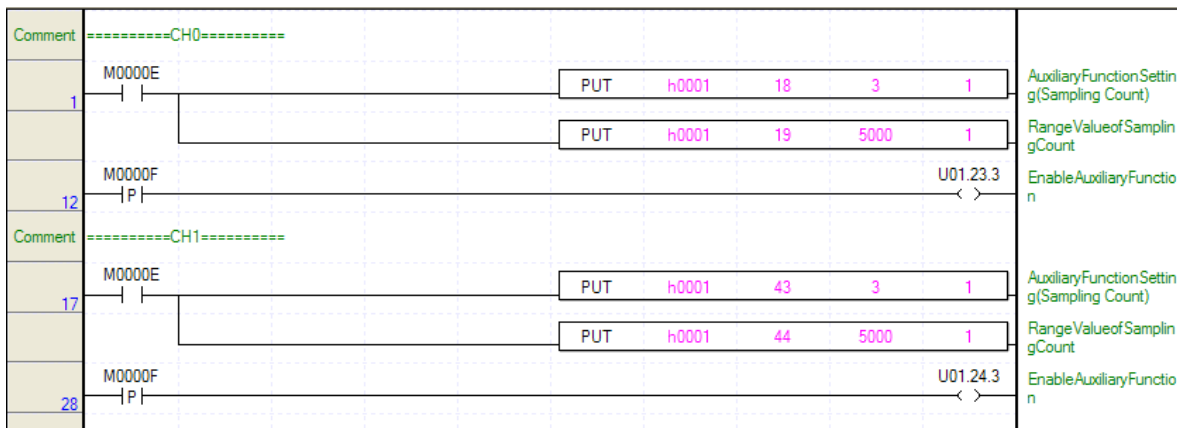

(b) Scan program of XEC series

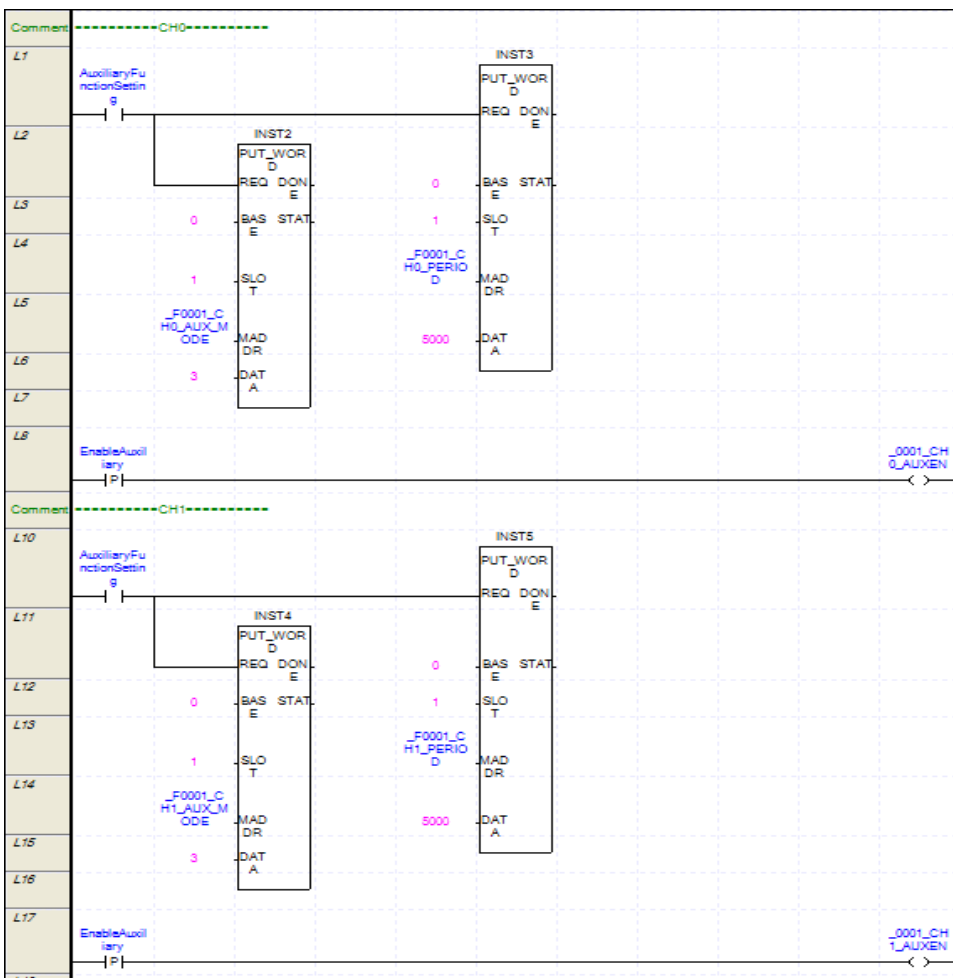

4. Input Freq. Measure

While Enable auxiliary function is on, input pulse is indicated at input frequency. Unit of input frequency is depending on setting of Frequency Mode.

(1) Setting content

Parameter	CH0	CH1
Auxiliary mode	4: Input Freq. measure	4: Input Freq. measure
Frequency Mode	1: 10Hz	1: 10Hz

(2) Program

(a) Scan program of XBM/XBC series

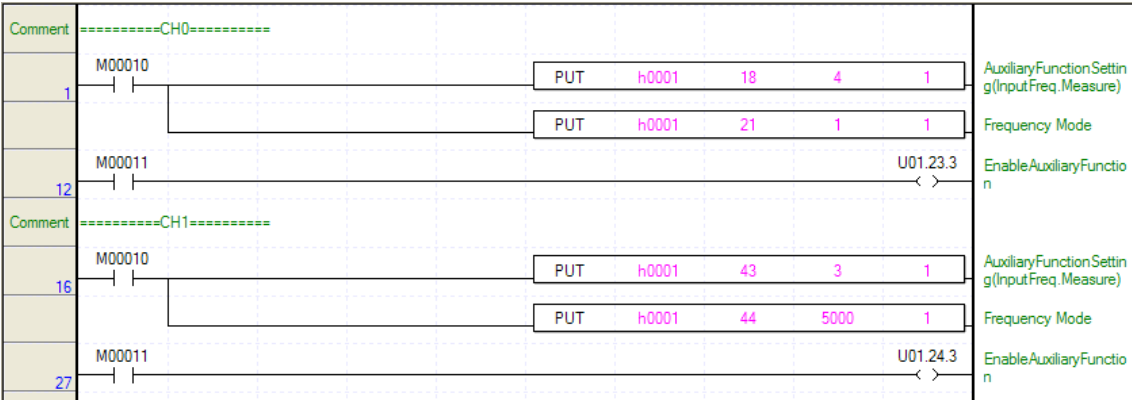

(b) Scan program of XEC series

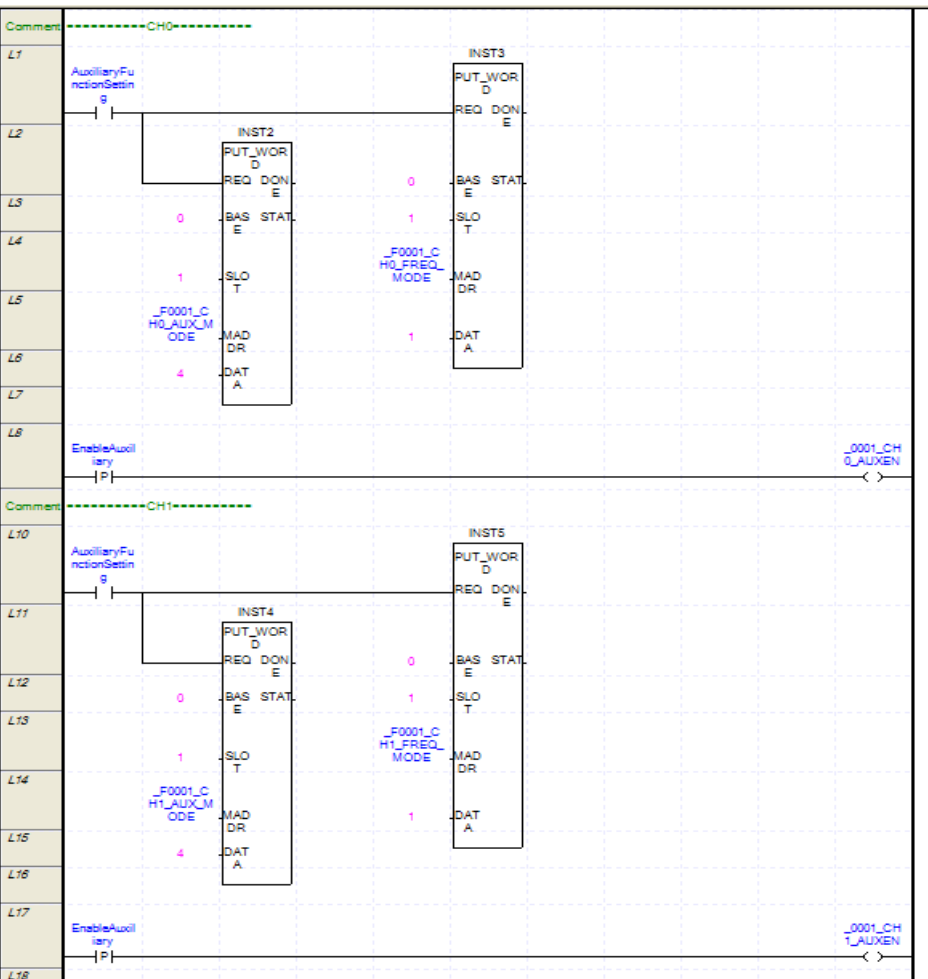

5. Revolution/Unit time

While Enable auxiliary mode is on, input pulse is calculated and indicated at revolution/unit time. For revolution/unit time, Range value and Pulse/Rev value should be set.

(1) Setting contents

Parameter	CH0	CH1
Auxiliary mode	5: Revolution/Unit time	5: Revolution/Unit time
Range value	1000	1000
Pulse/Rev value	200	200

(2) Program

(a) Scan program of XBM/XBC series

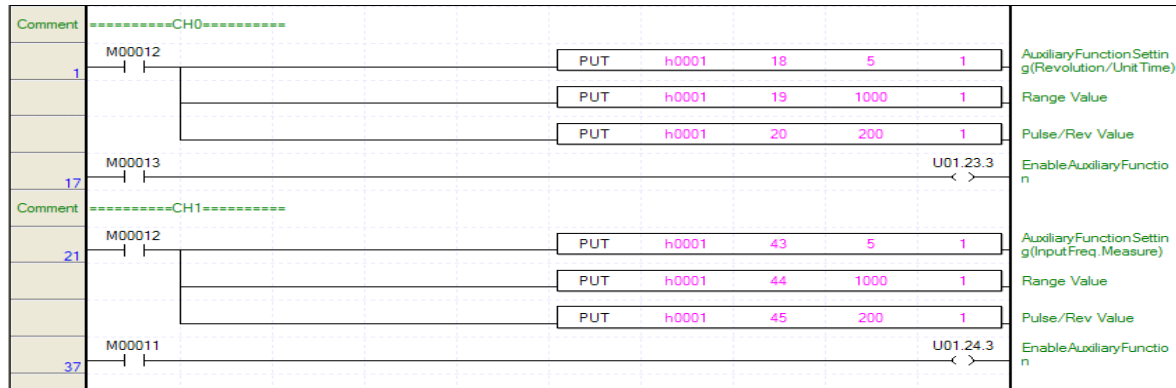

(b) Scan program of XECseries

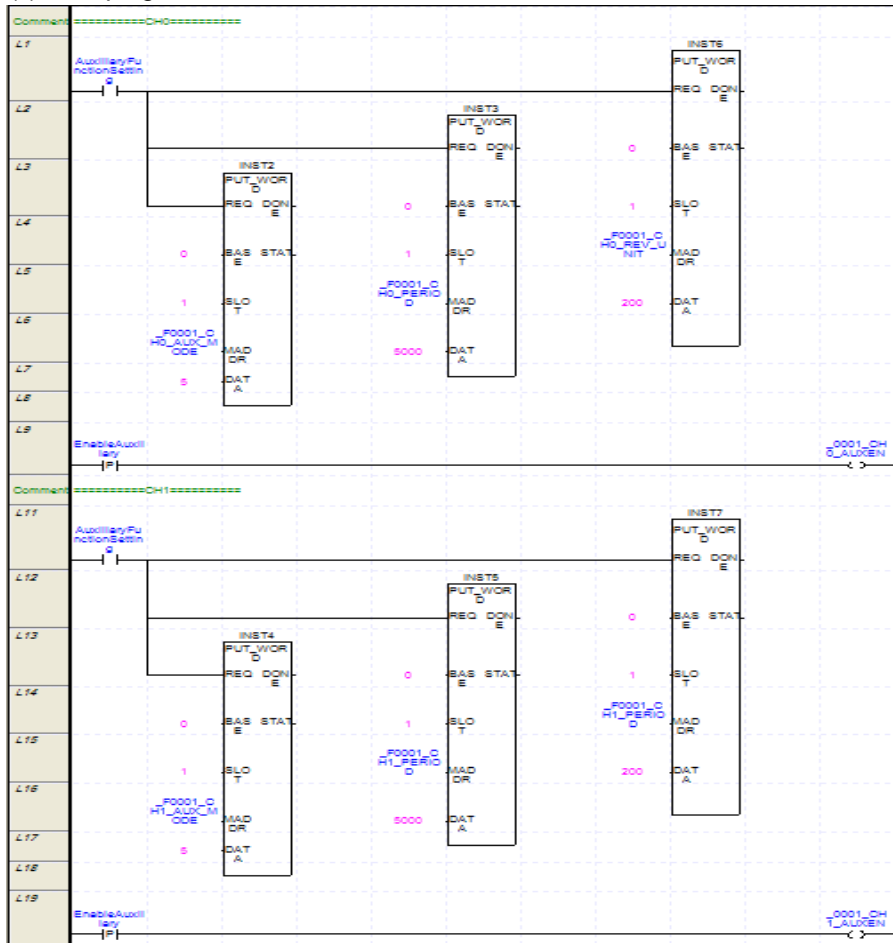

6. Counter Disable

While Enable auxiliary is on, counting is not executed.

(1) Setting contents

Parameter	CH0	CH1
Auxiliary mode	6: Count Disable	6: Count Disable

(2) Program

(a) Scan program of XBM/XBC series

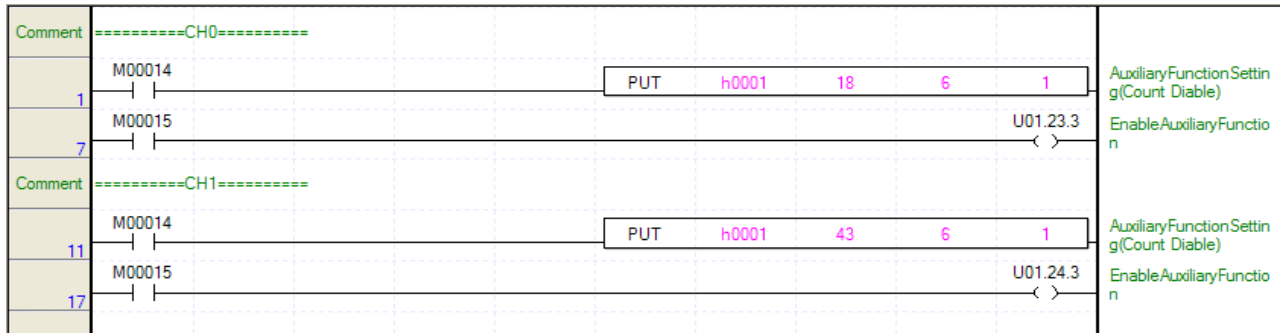

(b) Scan program of XECseries

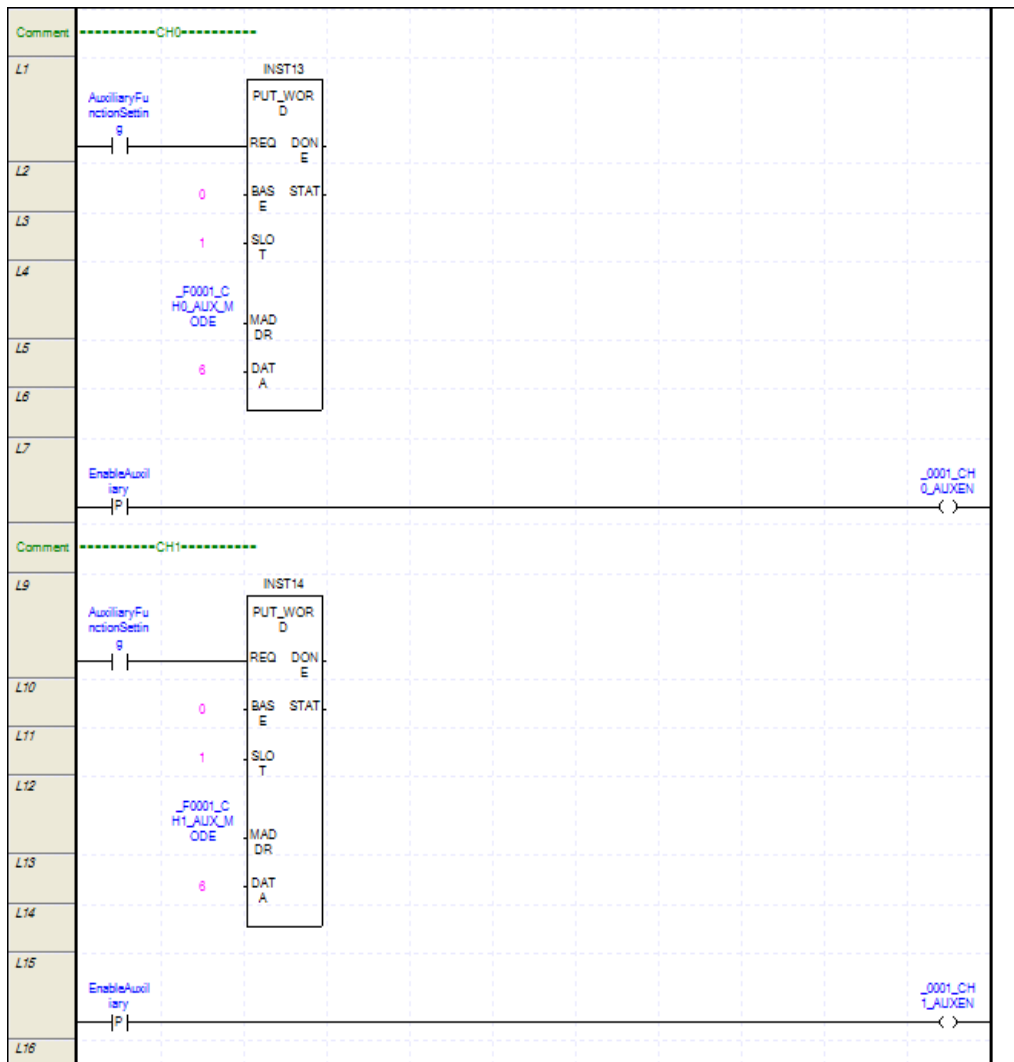

7.2.8 Up/down count selection

Program example selecting UP/Down count when input pulse is set as 1 phase 1 input 1 mutiplication/2 multiplication

1. Program

(a) Scan program of XBM/XBC series

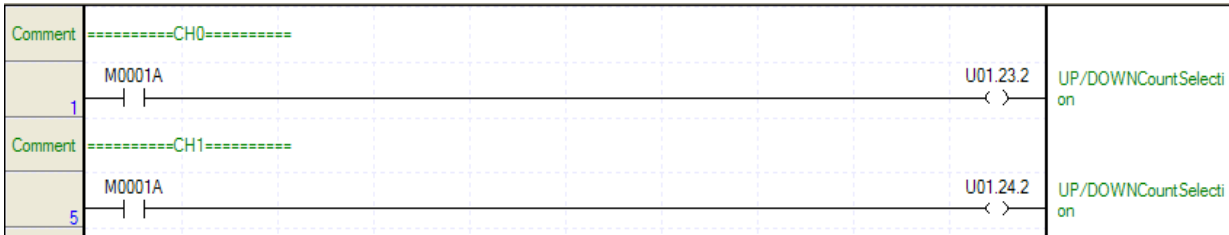

(b) Scan program of XECseries

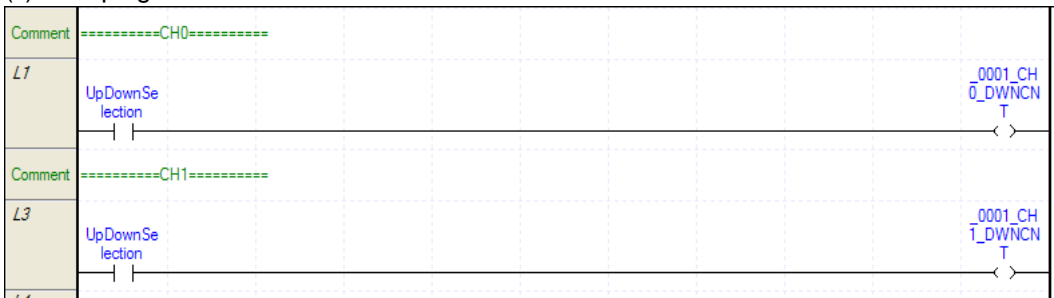

7.2.9 Use of external preset signal

Program examples allowing Enable preset by external preset signal and executing reset when external preset signal is detected

1. Program

(a) Scan program of XBM/XBC series

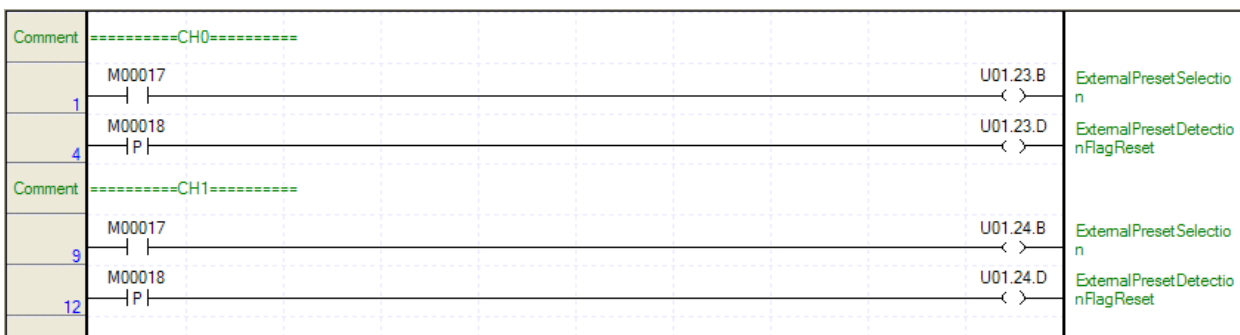

(b) Scan program of XECseries

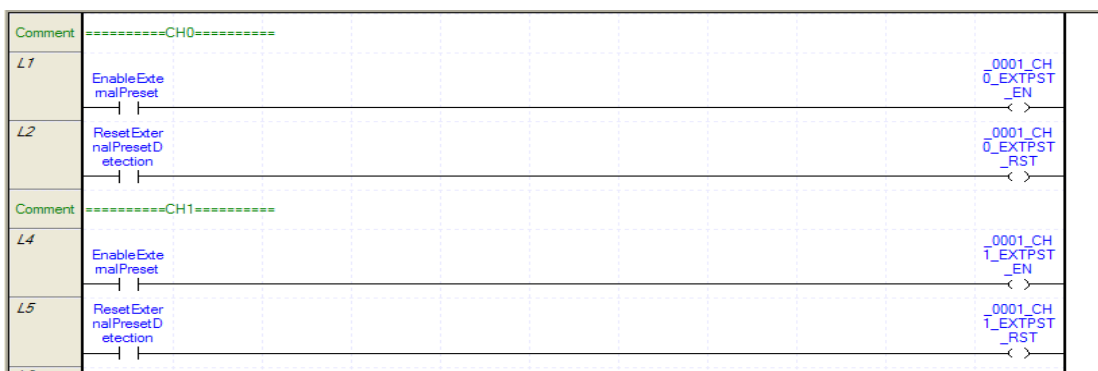

7.2.10 Use of external auxiliary function signal

Program example allowing Enable auxiliary function by external auxiliary function signal

1. Program

(a) Scan program of XBM/XBC series

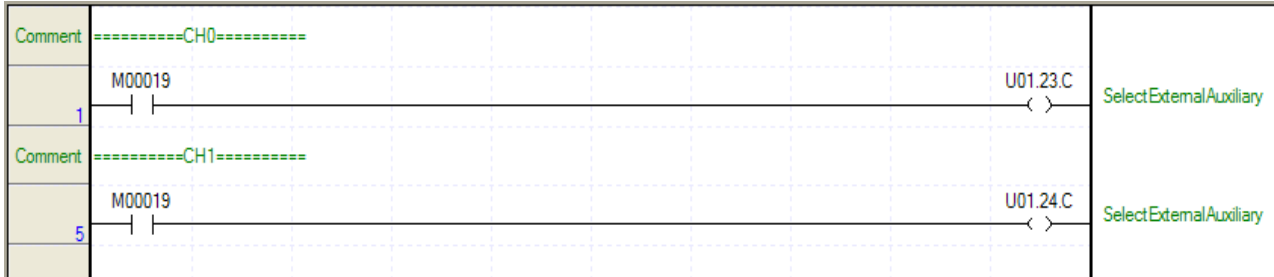

(b) Scan program of XECseries

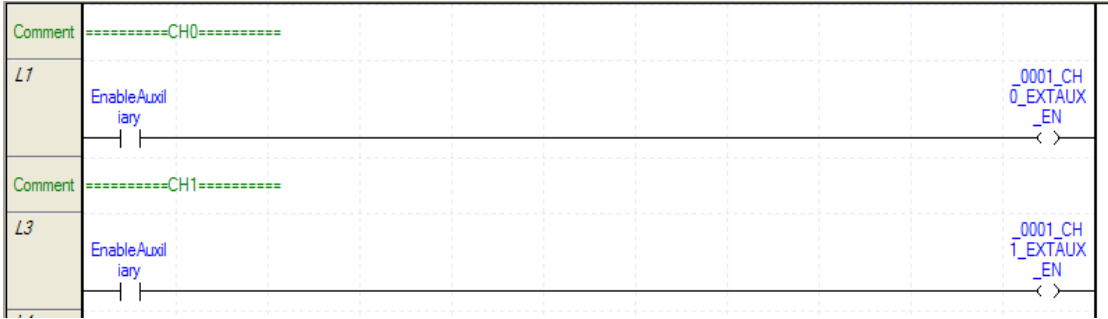

7.2.11 Type of comparison and comparison value setting

Program example explain type of comparison and comparison value setting

1. Setting content

Parameter	CH0		CH1	
	Comp output 0	Comp output 1	Comp output 0	Comp output 1
Comp output mode	1: ≤	5: ≤ ≤	1: ≤	5: ≤ ≤
Comp output min.	10	150	10	150
Comp output max.	150(No meaning)	300	150(No meaning)	300

2. Program

(a) Scan program of XBM/XBC seires

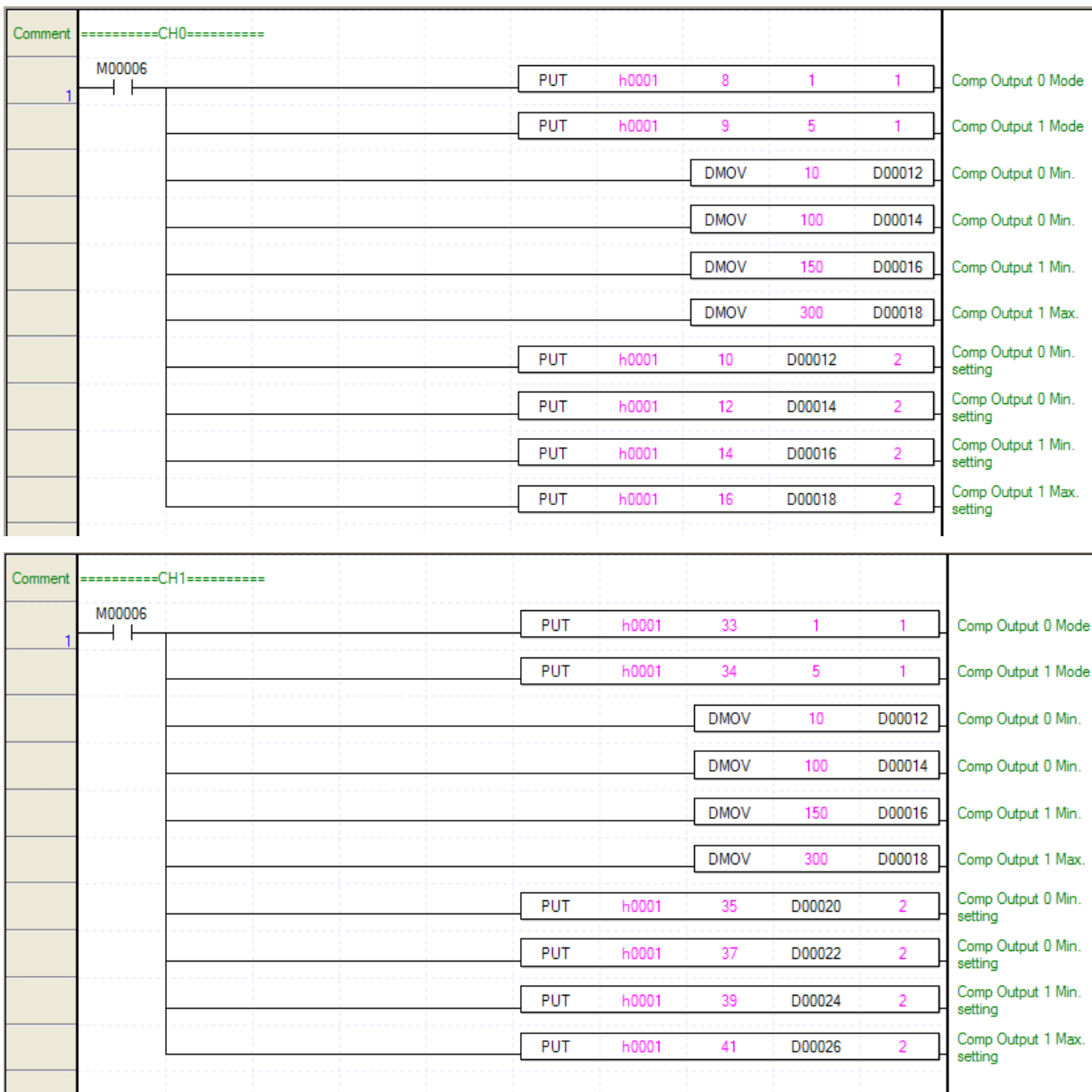

(b) Scan program of XECseries

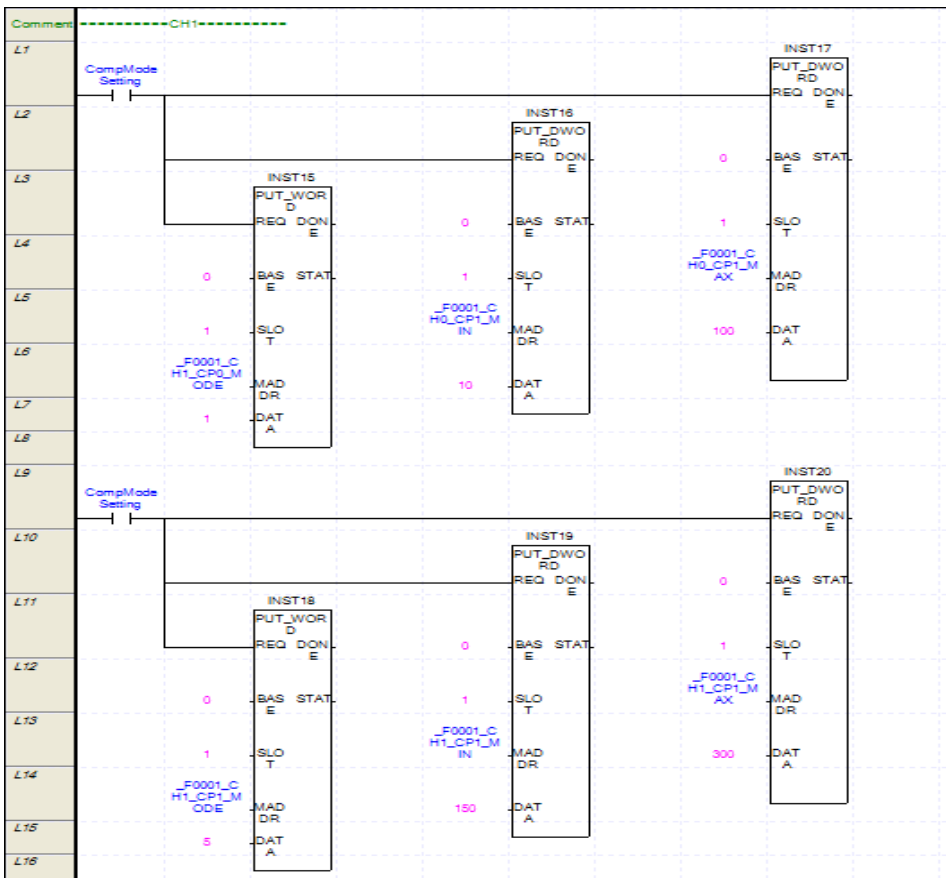
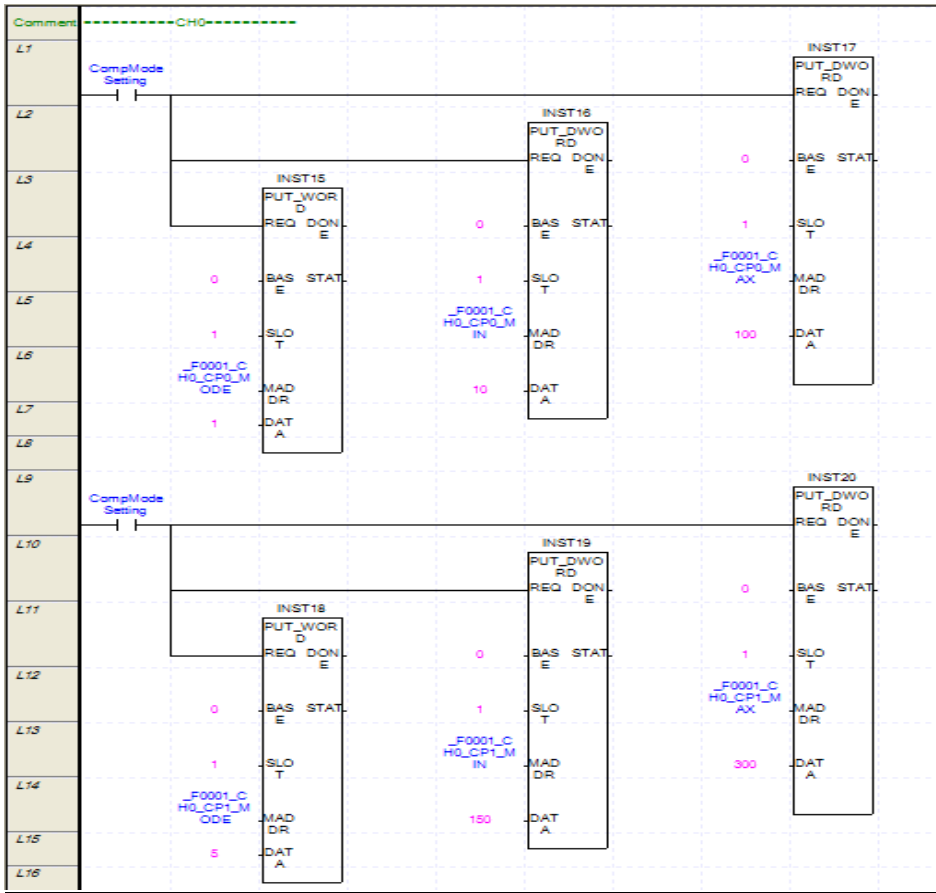

7.2.12 Enable comparison, Enable comparison output, Comparison agreement reset

Program example executing Enable comparison, Enable comparison output, Comparison agreement reset

1. Program

(a) Scan program of XBM/XBC series

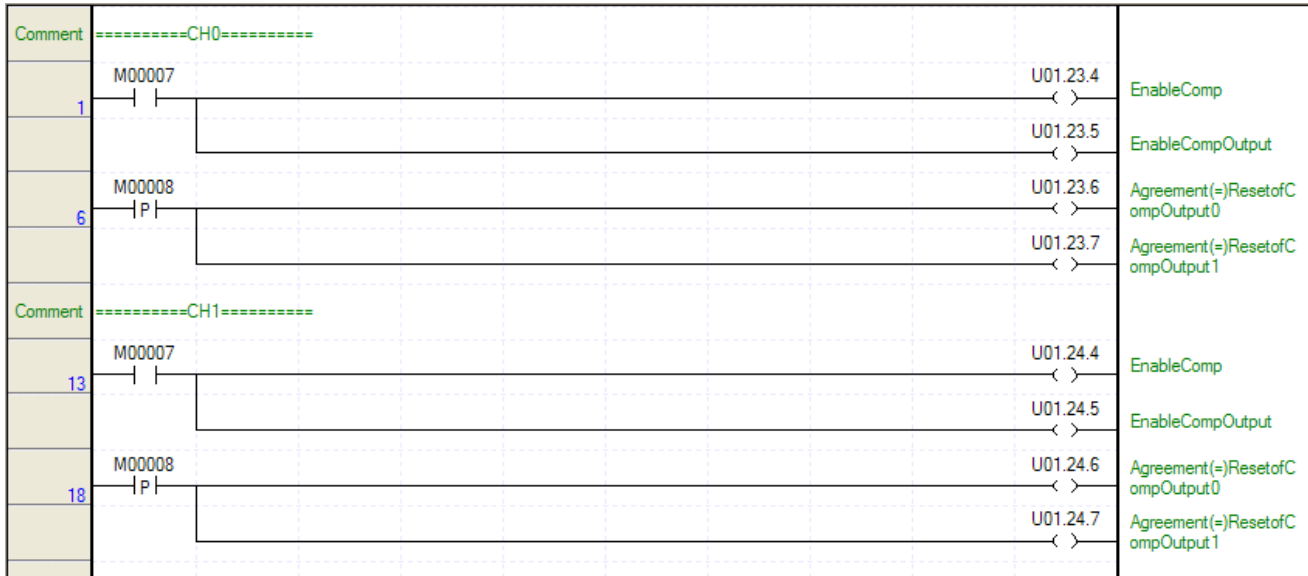

(b) Scan program of XECseries

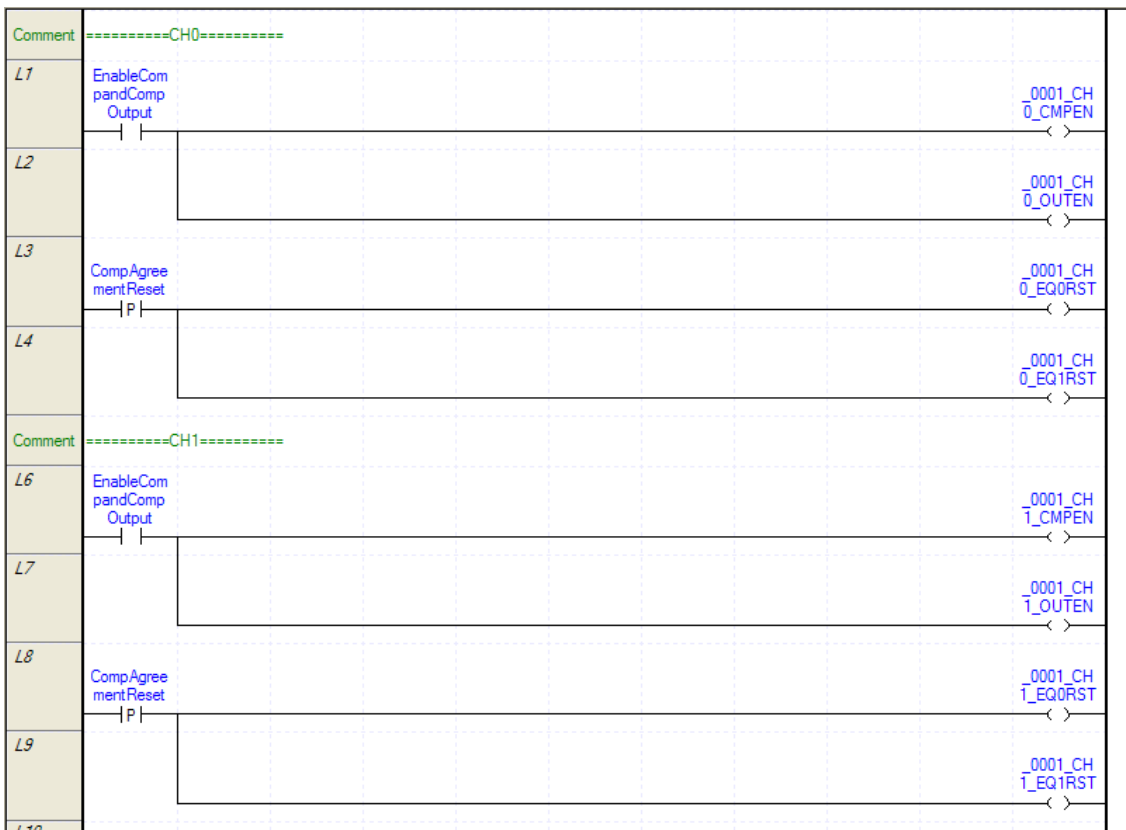

7.2.13 Comparison output status setting

Program example setting status of comparison output when XGB (XBM/XBC/XEC) CPU module is STOP.

1. Setting content

Parameter	CH0, CH1
Comparison output status when XGB CPU module is STOP	1: Hold comparison output

2. Program

(a) Scan program of XBM/XBC series

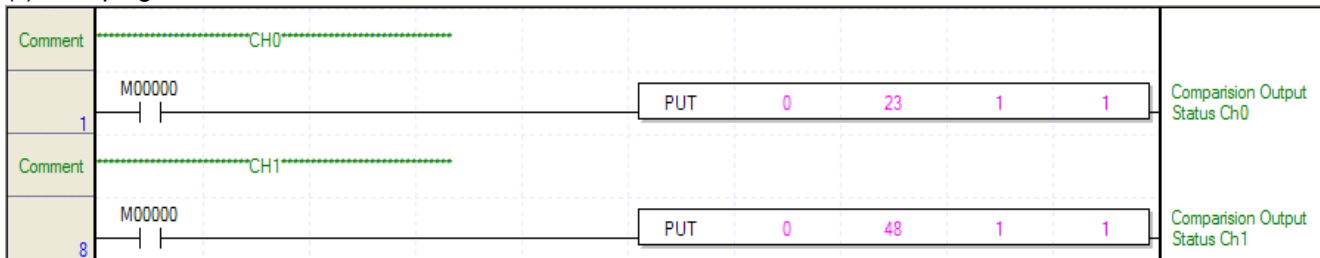

(b) Scan program of XEC series

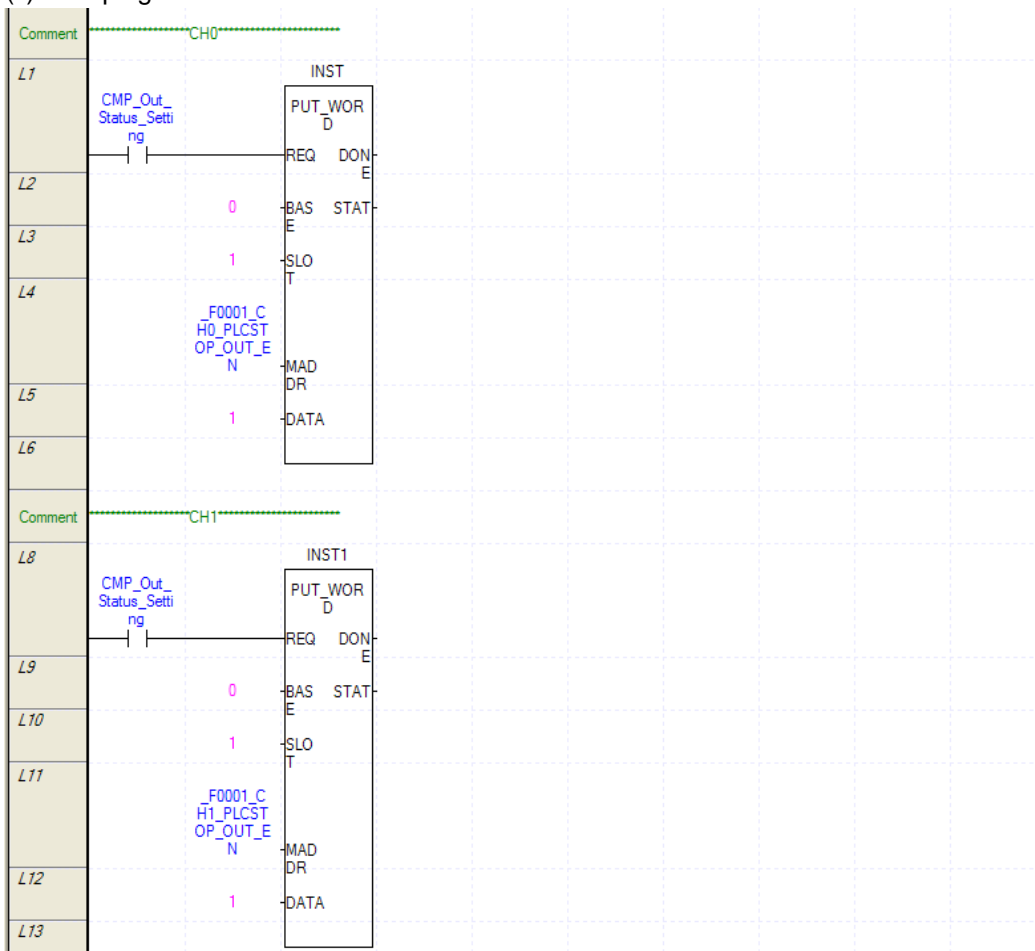

7.2.14 Input pulse Active level setting

Program example input pulse active level setting of HSC module.

1. Setting content

Parameter	Active Level
CH0 Input pulse active level	High Active
CH1 Input pulse active level	Low Active

1. Program

(a) Scan program of XBM/XBC series

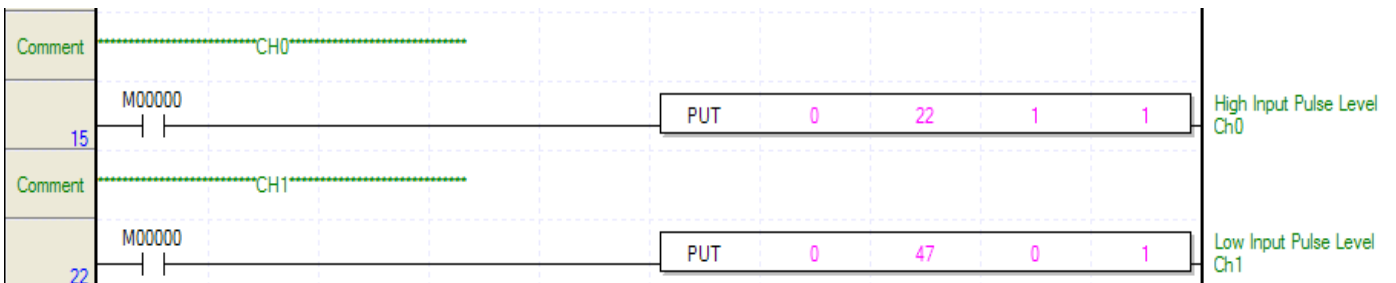

(b) Scan program of XEC series

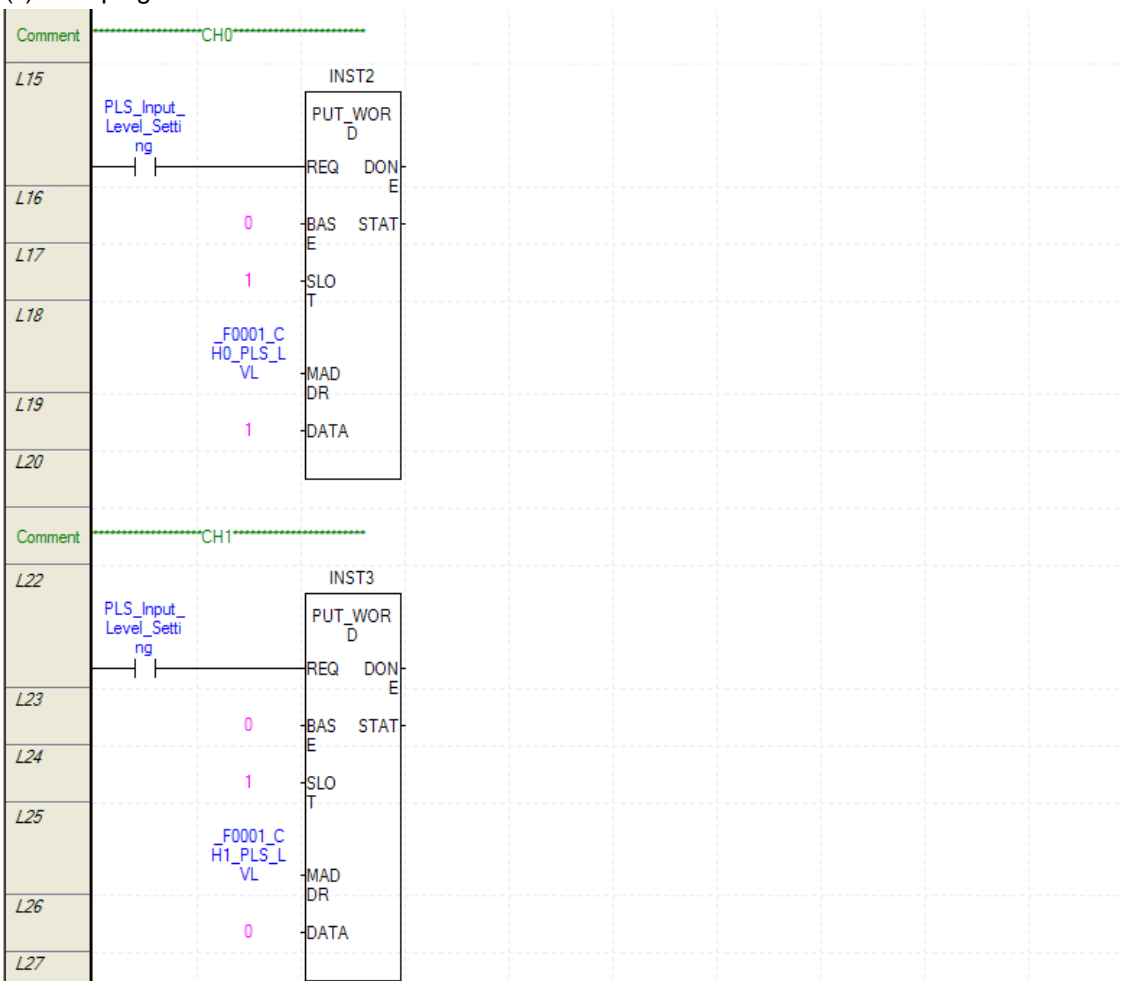

7.2.15 Error status and error code

Program example checking error status and error code occurred at HSC module

1. Program

(a) Scan program of XBM/XBC series

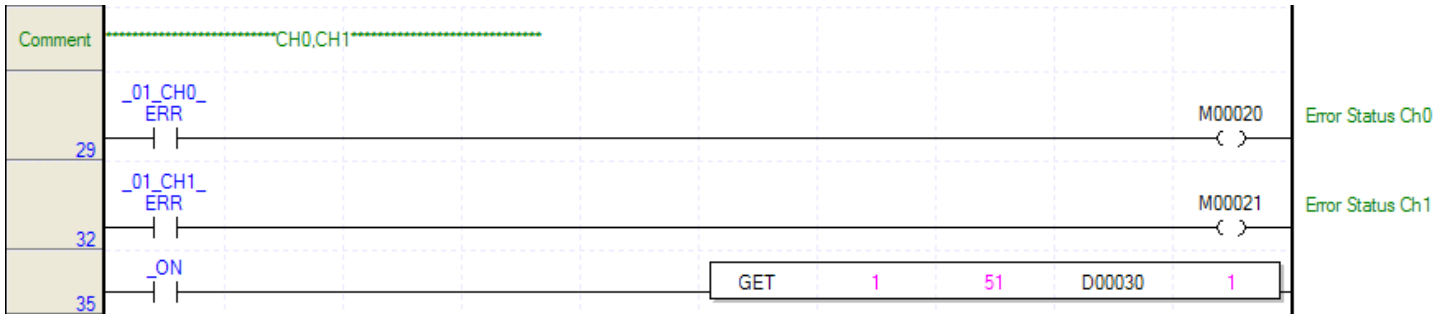

(b) Scan program of XEC series

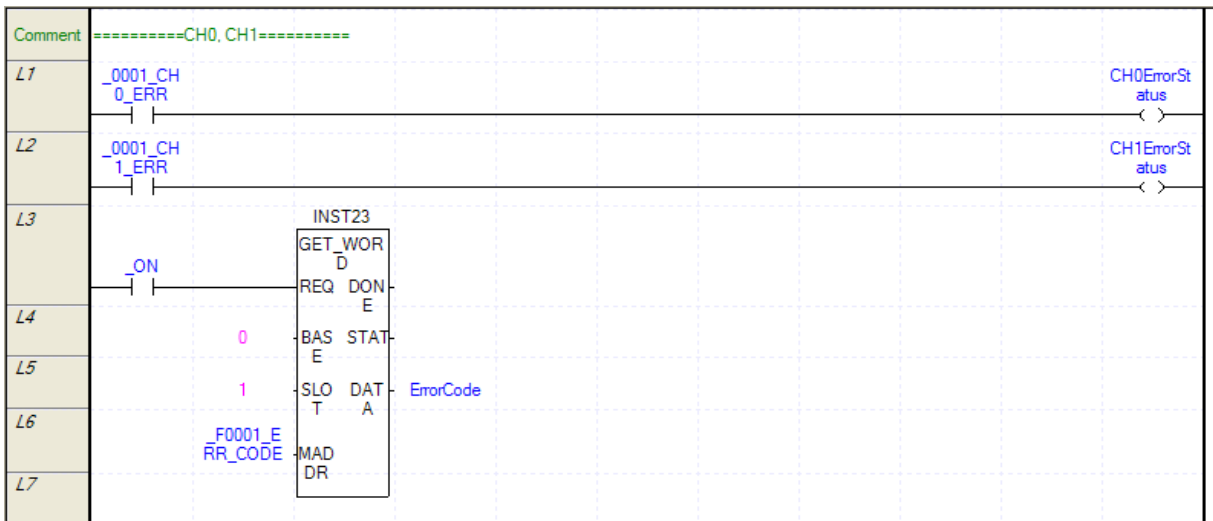

7.2.16 Hold count when power fails

Program example holding current count

To prepare when PLC power is off, current count is saved every scan and if PLC power restart, preset operation is executed with the saved count.

1. Program

(a) Scan program of XBM/XBC series

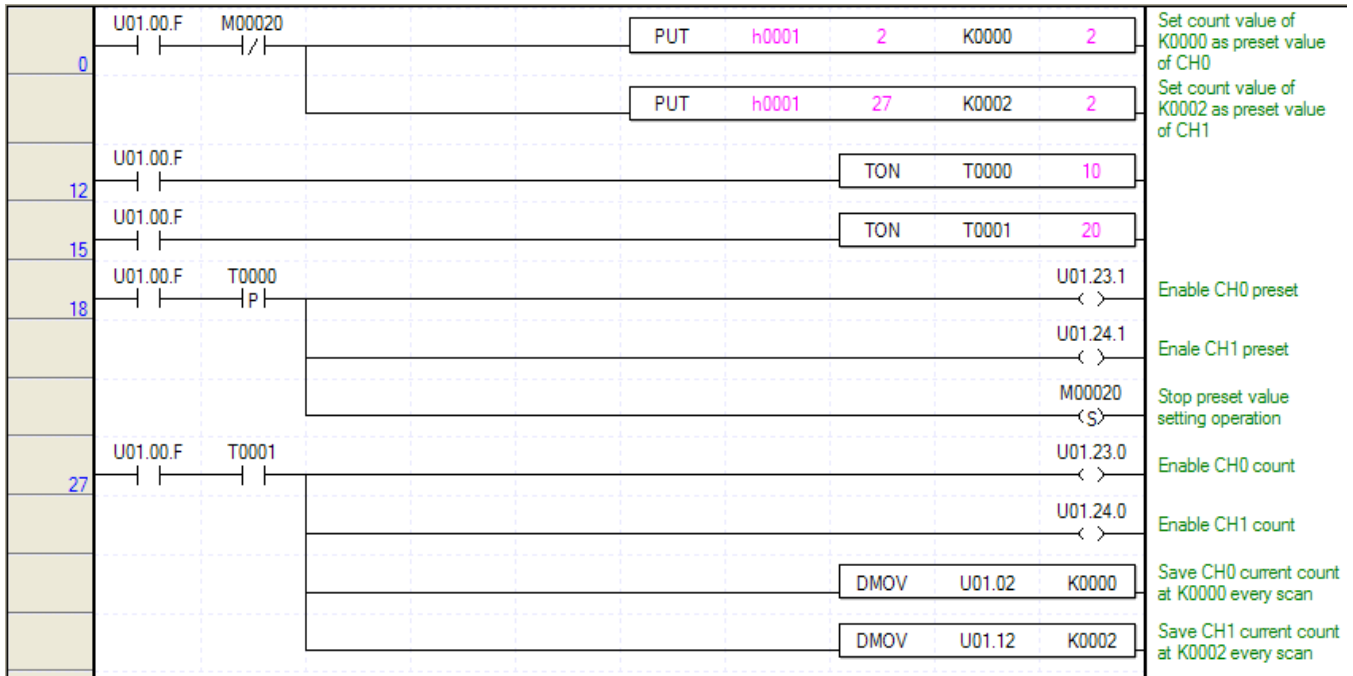

(b) Scan program of XEC series

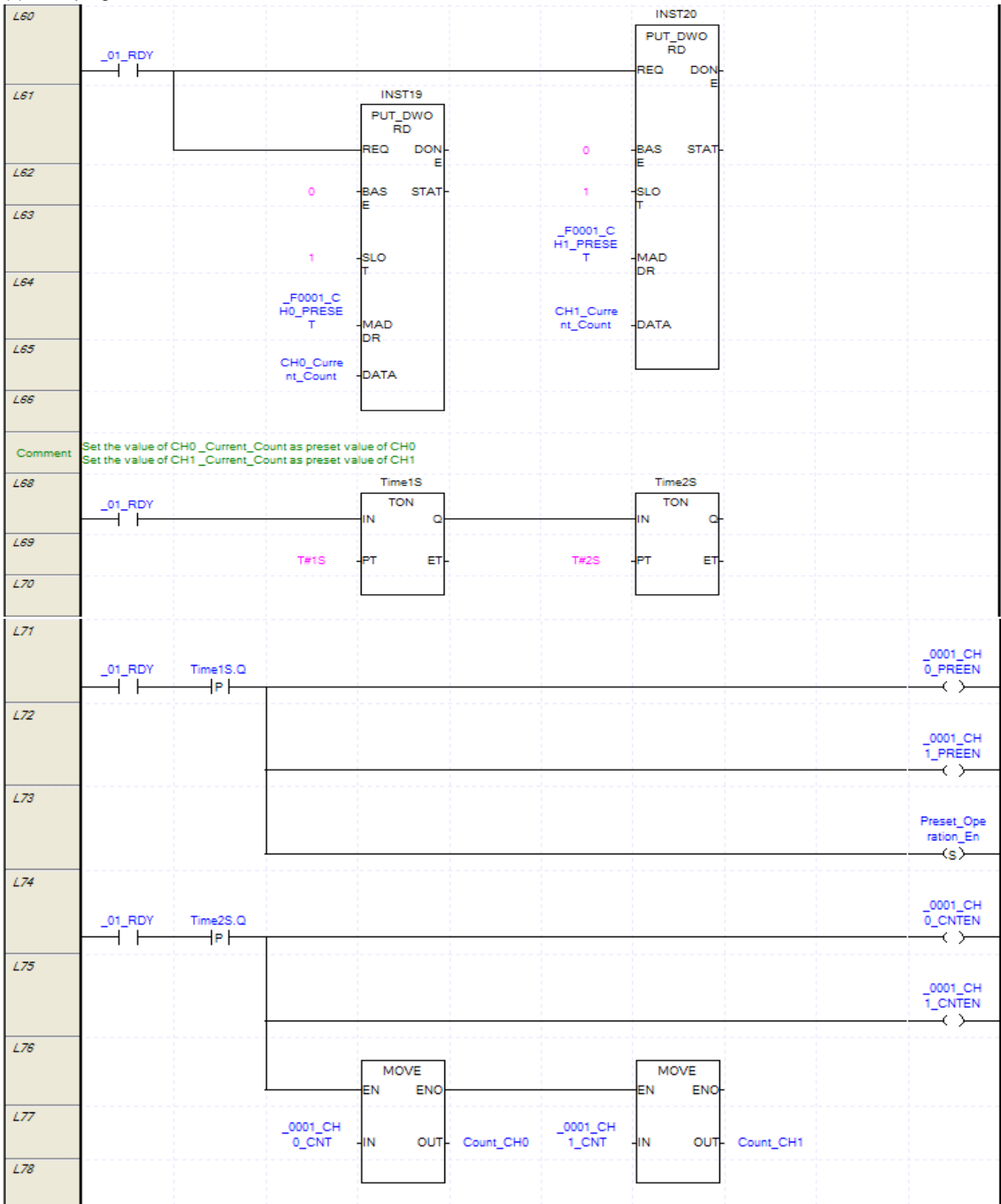

Remark

- (1) In the program, timer (TON) is used for safe operation of Preset value setting and preset allowance
- (2) In scan program of XEC series, to hold data of 'CH0 current count' and 'CH1 current count' when PLC power is off, the following setting is necessary.
- (a) On [Basic Parameter], set Restart Method as Warm Restart.

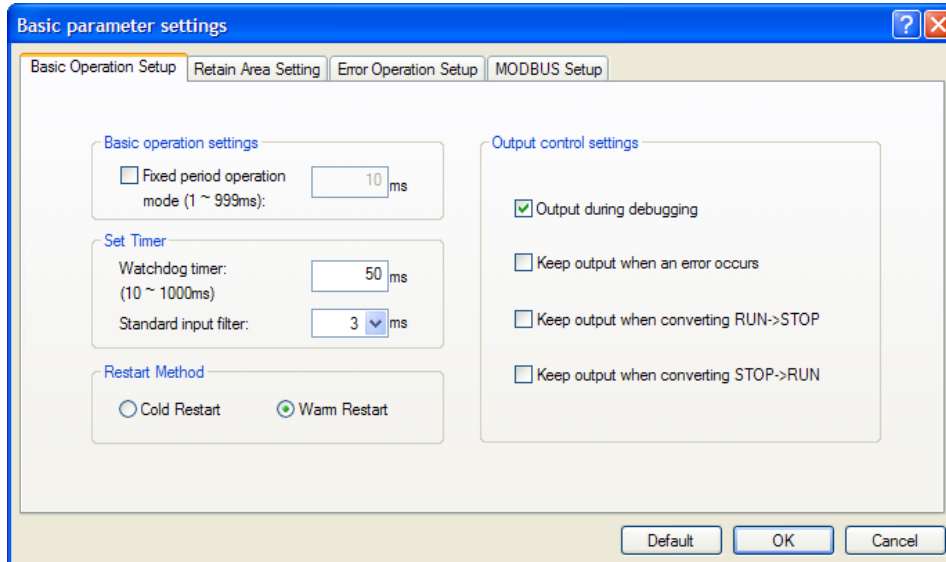

- (b) On scan program, set 'CH0 current count' and 'CH1 current count' as Retain variable.

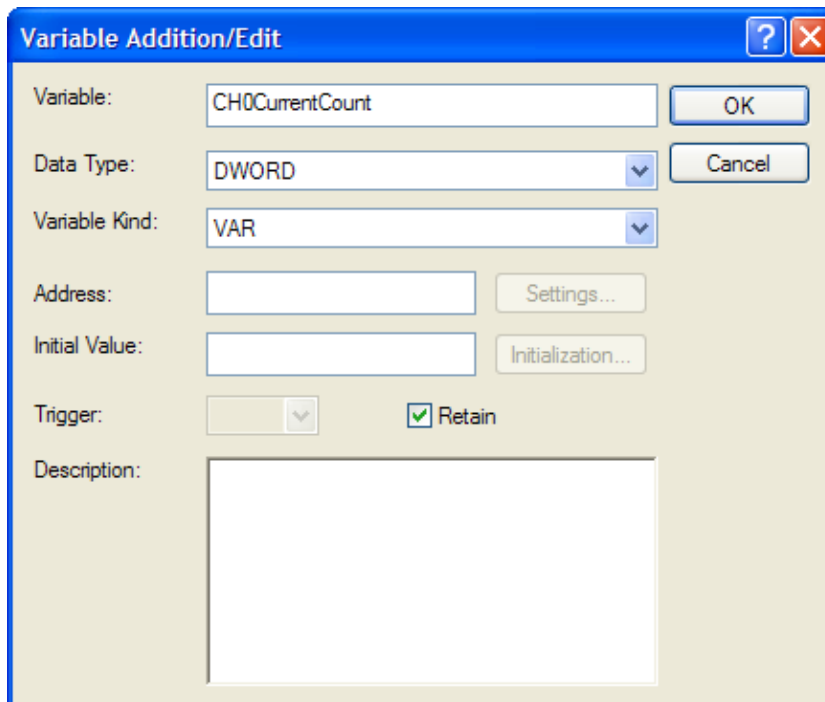

Chapter 8 Troubleshooting

How to shoot the troubles on the high speed counter module will be described.

Description

8.1 Error code

CH0	CH1	Description	RDY LED
10		Module error (ASIC Reset error)	Blinks every 0.2 sec.
11		Module error (ASIC Memory error)	
12		Module error (ASIC Register error)	
20	120	Counter type range exceeded	Blinks every 1 sec
21	121	Pulse input type range exceeded	
22	122	Auxiliary Mode type range exceeded	
23	123	Sampling Count value range exceeded	
24	124	Compared output0 type range exceeded	
25	125	Compared output1 type range exceeded	
26	126	Preset value exceeded counter range	
27	127	Ring counter minimum. value \geq Ring counter maximum value input	
28	128	Compared output 0 minimum value exceeded maximum input range	
29	129	Compared output 0 maximum value exceeded maximum input range	
30	130	Compared output 0 minimum value > compared output 0 maximum value set	
31	131	Compared output 1 minimum value exceeded maximum input range	
32	132	Compared output 1 maximum value exceeded maximum input range	
33	133	Compared output 1 minimum value > compared output1 maximum value set	
34	134	Pulses per revolution range exceeded	
35	135	Frequency input mode range exceeded	
36	136	Main unit stop Compared output retain parameter error	

Notes

- (1) If the module is normal, RDY LED is On.
- (2) If 2 or more errors occur, the module will save the first error code generated, and the displayed error will be first deleted to let the next error deleted.
- (3) In case of serious error which makes RDY LED blinks every 0.2 sec., let power Off → On to delete the error.
- (4) In case of slight error which makes RDY LED blinks every 1 sec., the error can be deleted without power Off → On and the module can keep operating.
- (5) In case of slight error which makes RDY LED blinks every 1 sec, the parameter value causing the applicable error is not set on the module, with the existing parameter value kept as it is.

8.2 Troubleshooting

8.2.1 LED display status of the high speed counter module

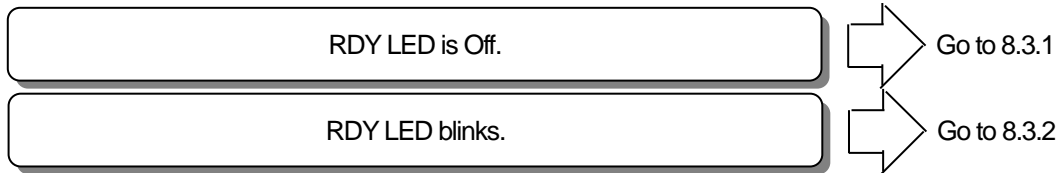

8.2.2 Counter status of the high speed counter module

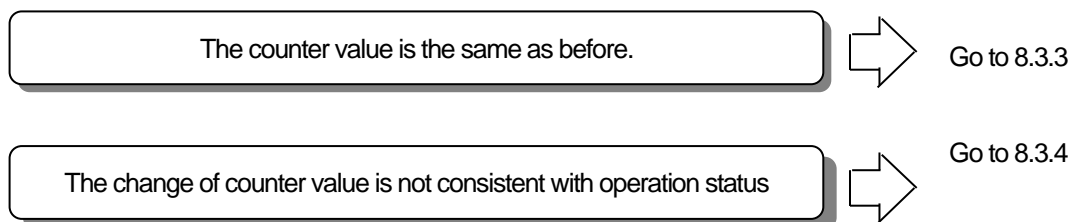

8.2.3 Output status of the high speed counter module

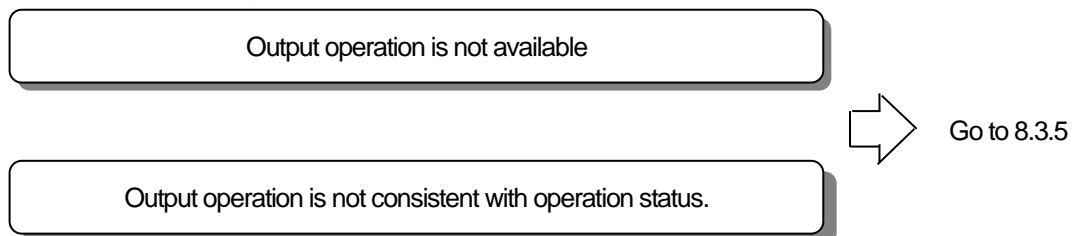

8.3 Troubleshooting sequence

8.3.1 RDY LED Off

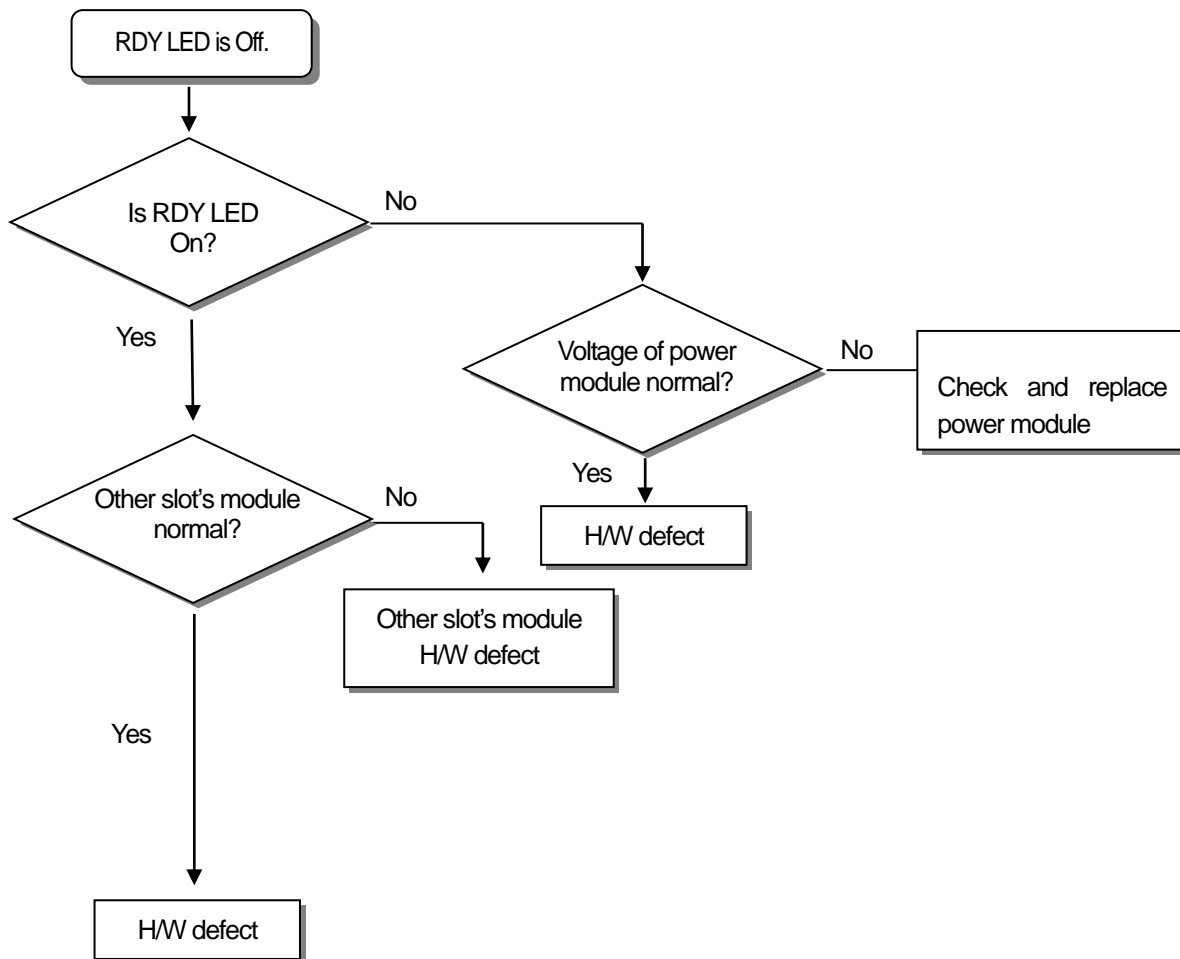

8.3.2 RDY LED Blinks

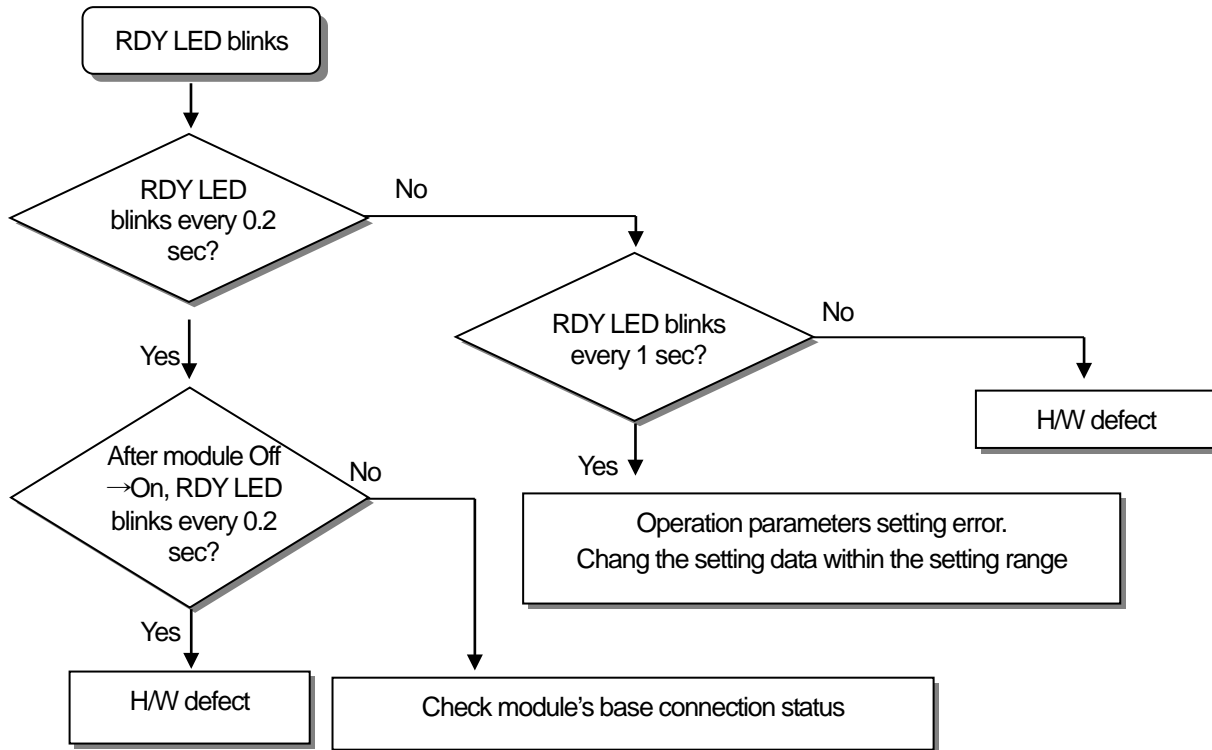

8.3.3 Counter operation error

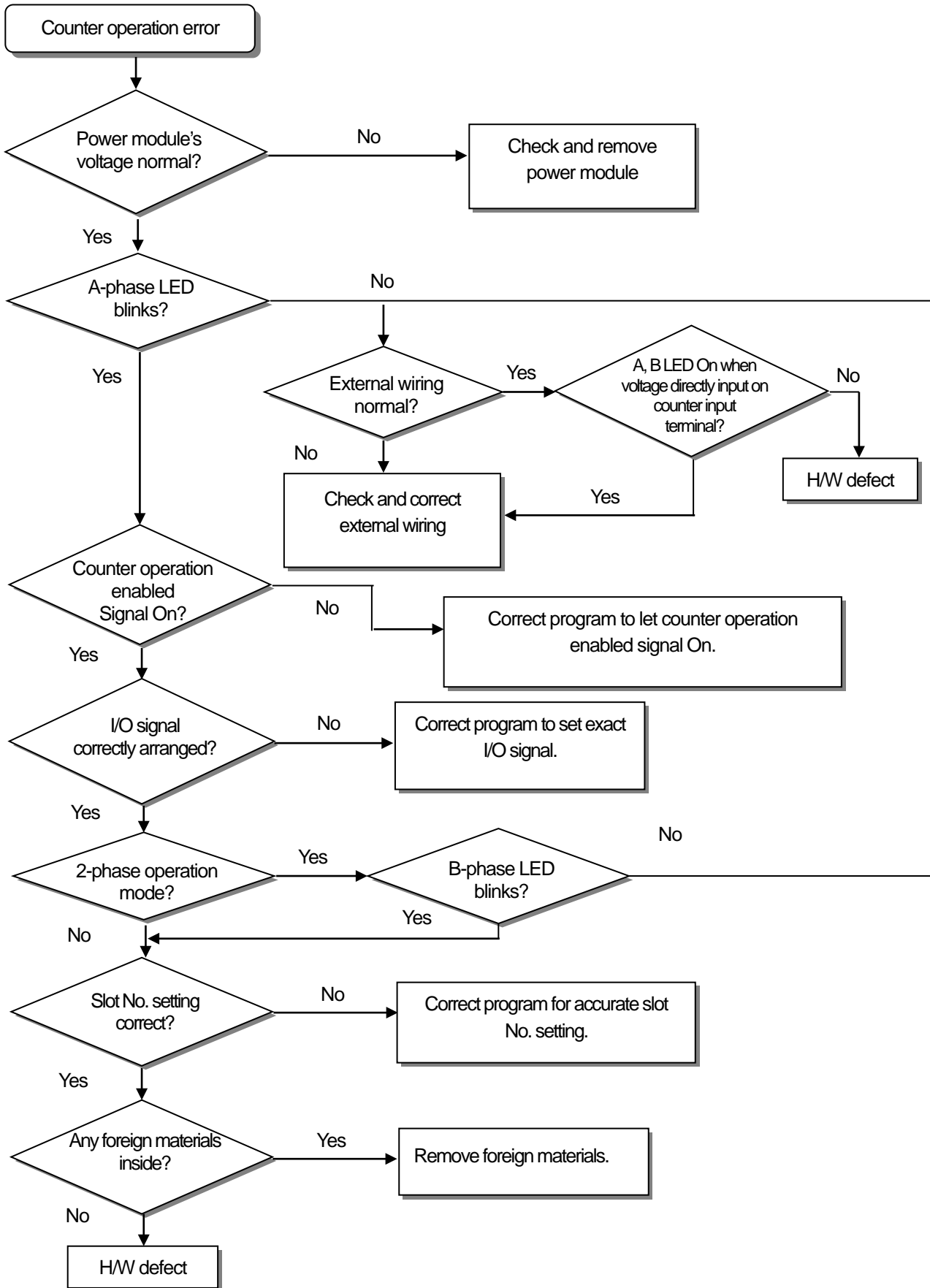

8.3.4 Counter value error

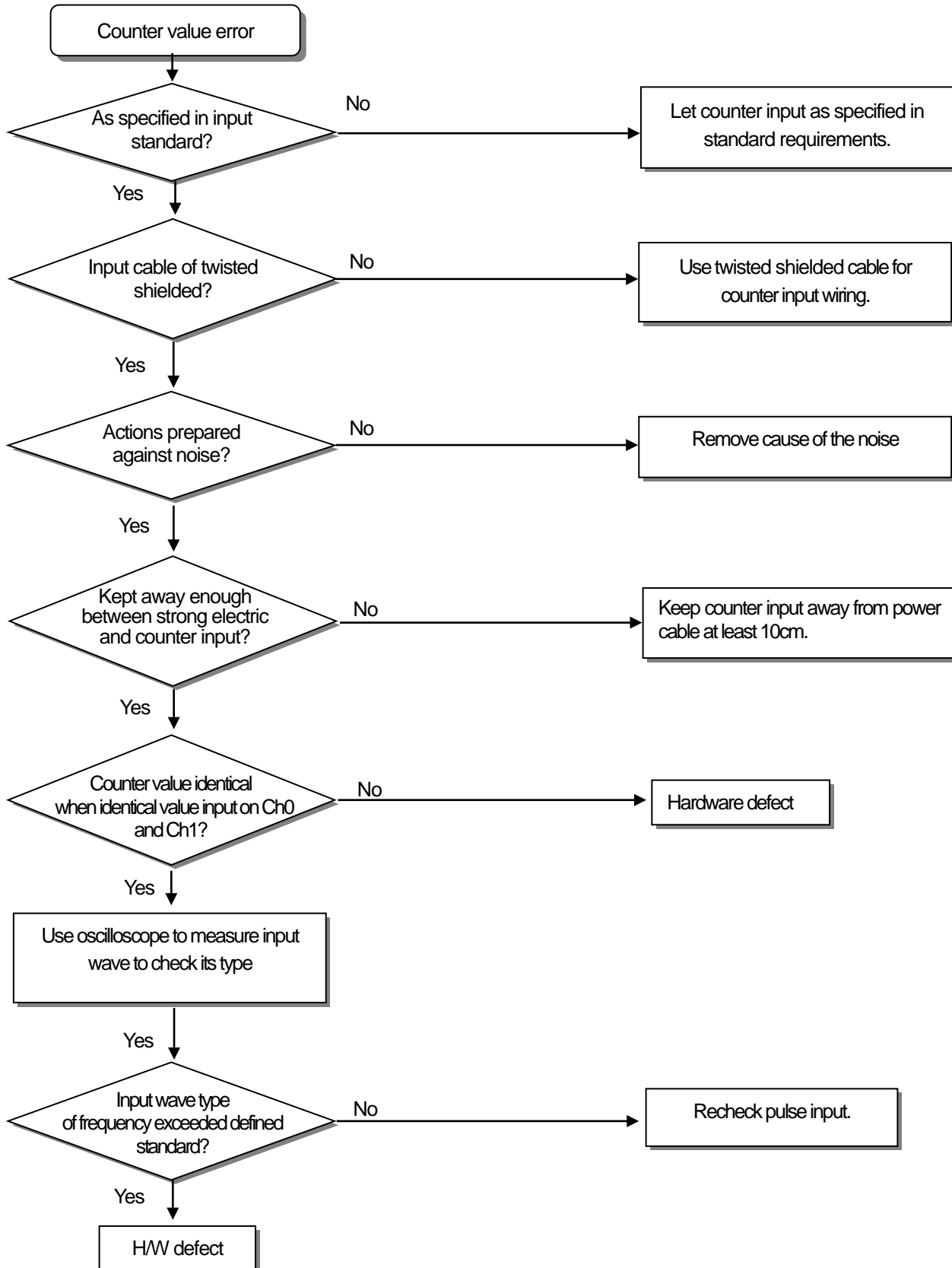

8.3.5 Output operation error

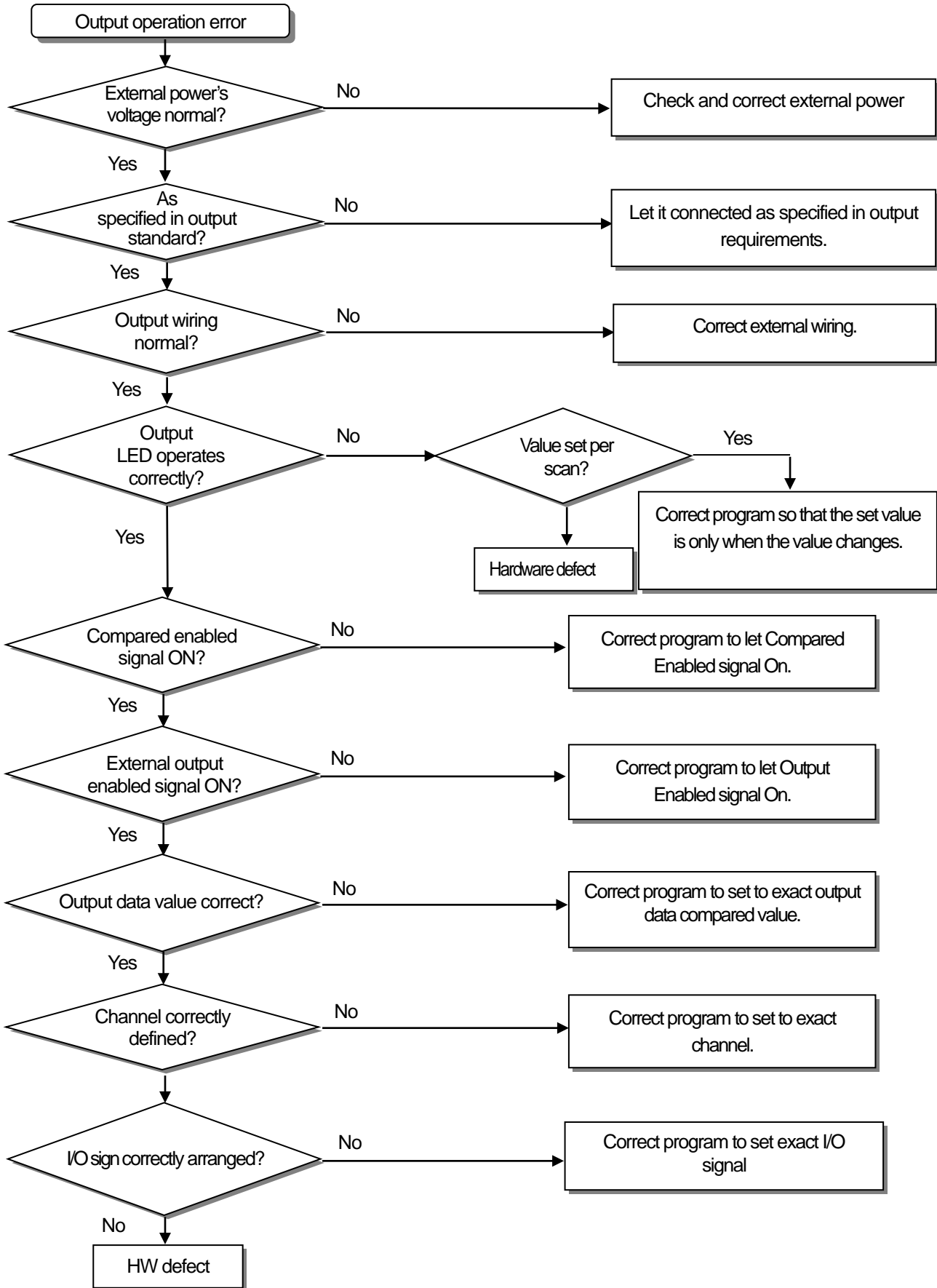

8.4 Module status check through XG5000 system monitoring

Module type, module information, OS version and module status of HSC module can be checked through XG5000 system monitoring function.

8.4.1 Execution sequence

[Monitor] -> [System Monitoring] -> and on the module screen, click the right mouse button to display [Module Information].

8.4.2 Module information

1. Module Info: shows the information of the module presently installed.
2. OS version: shows the OS version information of the high speed counter module.
3. OS date: shows the OS prepared date of the high speed counter module.
4. Module status: shows the present error code.

8.4.3 System Monitoring

The screenshot displays the 'NewPLC - System Monitoring - [Base 0]' window. A 'Special Module Information' dialog box is open, showing details for the XBF-HD02A module. The dialog box contains the following table:

Item	Information
Module Name	XBF-HD02A (Line-Driver, 2-CH)
OS Ver	Ver. 0.09
OS Update Date	2011-12-14
Module Status	Normal. (0)

The background shows a rack of modules with the following configuration:

- Slot 0: Internal Cnet
- Slot 1: XBE-RV16A
- Slot 2: XBF-HD02A
- Slot 3: XBE-RV16A
- Slot 4: Empty slot

The status bar at the bottom indicates 'Ready', 'XGB-XBCS', 'Online', and 'L, USB, Warning'.

Appendix 1 Terminology

1. Pulse

Used to turn voltage (current) On/Off for a short time, and pulse line is of continuous pulses

2. Encoder

Used mainly in servo-detector in order to detect speed and position, whose basic principle is that if infrared ray from LED passes the slit disk and reaches the light receiving element, analog electric sign is output which will be converted by voltage comparator to digital sign to be output.

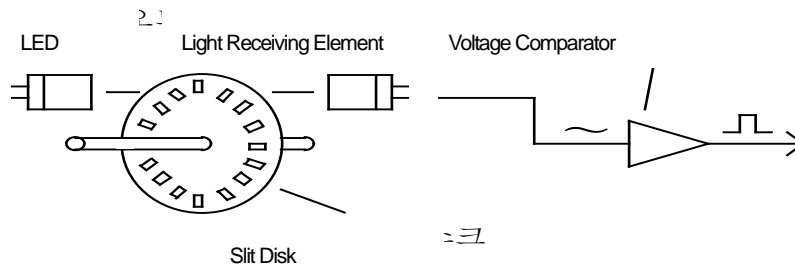

Encoder output

- (1) A phase: Basic output, signal of pulses is output as many as the number of resolutions for 1 revolution of shaft.
- (2) B phase: Signal with a specific phase difference from A phase, which can detect revolution direction of shaft
- (3) Z phase: 1 pulse is output for 1 revolution of shaft.

3. MPG(Manual Pulse Generator)

A device that handle can be rotated by hand to generate pulses. If rotated + direction, forward pulses are generated, and if rotated – direction, reverse pulses are generated.

4. Up Count

A counter value increases from -2,147,483,648 to 2,147,483,647 (for 32-bit counter).

5. Down Count

A counter value decreases from 2,147,483,647 to -2,147,483,648 (for 32-bit counter).

6. Ring Count

A counter that counter value increases/decreases between the maximum value and the minimum value of the Ring count that user has defined.

7. 1-Phase Operation Mode

Mode used to count 1-phase input pulse.

8. CW/CCW Operation Mode

Mode used to count another 1-phase if 1 phase is Low among 2-phase input pulses.

9. 2-Phase Operation Mode

Mode used to count 2-phase input pulse.

10. Preset

Mode used to set present counter value to discretionary value.

11. Gate

Signal used to enable additional function operation.

12. Compared Value

Basic value used to compare counters in size.

13. Carry

Signal displayed when Linear count changes from 2,147,483,646 to 2,147,483,647 and when Ring count changes from the maximum value to the minimum value with increasing counter operation.

14. Borrow

Signal displayed when Linear count changes from -2,147,483,647 → -2,147,483,648 and when Ring count changes from the minimum value to the maximum value with decreasing counter operation.

15. External Preset Signal

External signal used to change present counter value to discretionarily specified value.

16. External Gate Signal

External signal used to enable the additional function operation.

Appendix 2 Dimensions

Appendix 2 Dimensions

Unit: mm

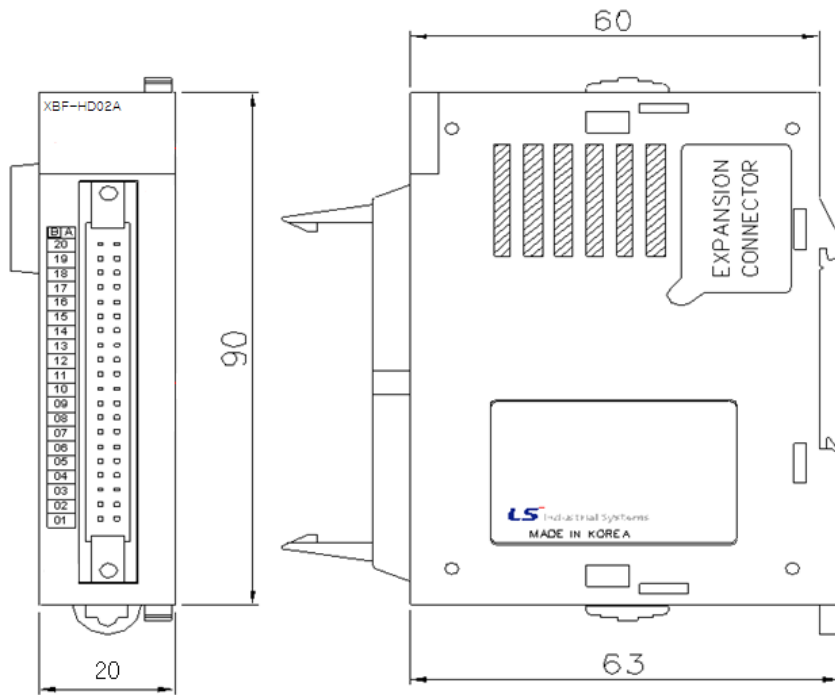

Remark

XBF-HO02A and XBF-HD02A are same size.

Warranty

1. Warranty Period

The product you purchased will be guaranteed for 18 months from the date of manufacturing.

2. Scope of Warranty

Any trouble or defect occurring for the above-mentioned period will be partially replaced or repaired. However, please note the following cases will be excluded from the scope of warranty.

- (1) Any trouble attributable to unreasonable condition, environment or handling otherwise specified in the manual,
- (2) Any trouble attributable to others' products,
- (3) If the product is modified or repaired in any other place not designated by the company,
- (4) Due to unintended purposes
- (5) Owing to the reasons unexpected at the level of the contemporary science and technology when delivered.
- (6) Not attributable to the company; for instance, natural disasters or fire

3. Since the above warranty is limited to PLC unit only, make sure to use the product considering the safety for system configuration or applications.

Environmental Policy

LS ELECTRIC Co., Ltd supports and observes the environmental policy as below.

Environmental Management

LS ELECTRIC considers the environmental preservation as the preferential management subject and every staff of LS ELECTRIC use the reasonable endeavors for the pleasurable environmental preservation of the earth.

About Disposal

LS ELECTRIC PLC unit is designed to protect the environment. For the disposal, separate aluminum, iron and synthetic resin (cover) from the product as they are reusable.



www.ls-electric.com

LS ELECTRIC Co., Ltd.

■ Headquarter

LS-ro 127(Hogye-dong) Dongan-gu, Anyang-si, Gyeonggi-Do, 14119, Korea

■ Seoul Office

LS Yongsan Tower, 92, Hangang-daero, Yongsan-gu, Seoul, 04386, Korea

Tel: 82-2-2034-4033, 4888, 4703 Fax: 82-2-2034-4588

E-mail: automation@ls-electric.com

■ Overseas Subsidiaries

• LS ELECTRIC Japan Co., Ltd. (Tokyo, Japan)

Tel: 81-3-6268-8241 E-Mail: japan@ls-electric.com

• LS ELECTRIC (Dalian) Co., Ltd. (Dalian, China)

Tel: 86-411-8730-6495 E-Mail: china.dalian@lselectric.com.cn

• LS ELECTRIC (Wuxi) Co., Ltd. (Wuxi, China)

Tel: 86-510-6851-6666 E-Mail: china.wuxi@lselectric.com.cn

• LS ELECTRIC Middle East FZE (Dubai, U.A.E.)

Tel: 971-4-886-5360 E-Mail: middleeast@ls-electric.com

• LS ELECTRIC Europe B.V. (Hoofddorp, Netherlands)

Tel: 31-20-654-1424 E-Mail: europartner@ls-electric.com

• LS ELECTRIC America Inc. (Chicago, USA)

Tel: 1-800-891-2941 E-Mail: sales.us@lselectricamerica.com

• LS ELECTRIC Turkey Co., Ltd.

Tel: 90-212-806-1225 E-Mail: turkey@ls-electric.com

■ Overseas Branches

• LS ELECTRIC Tokyo Office (Japan)

Tel: 81-3-6268-8241 E-Mail: tokyo@ls-electric.com

• LS ELECTRIC Beijing Office (China)

Tel: 86-10-5095-1631 E-Mail: china.auto@lselectric.com.cn

• LS ELECTRIC Shanghai Office (China)

Tel: 86-21-5237-9977 E-Mail: china.auto@lselectric.com.cn

• LS ELECTRIC Guangzhou Office (China)

Tel: 86-20-3818-2883 E-Mail: china.auto@lselectric.com.cn

• LS ELECTRIC Chengdu Office (China)

Tel: 86-28-8670-3201 E-Mail: china.auto@lselectric.com.cn

• LS ELECTRIC Qingdao Office (China)

Tel: 86-532-8501-2065 E-Mail: china.auto@lselectric.com.cn

• LS ELECTRIC Nanjing Office (China)

Tel: 86-25-8467-0005 E-Mail: china.auto@lselectric.com.cn

• LS ELECTRIC Bangkok Office (Thailand)

Tel: 66-90-950-9683 E-Mail: thailand@ls-electric.com

• LS ELECTRIC Jakarta Office (Indonesia)

Tel: 62-21-2933-7614 E-Mail: indonesia@ls-electric.com

• LS ELECTRIC Moscow Office (Russia)

Tel: 7-499-682-6130 E-Mail: info@lselectric-ru.com

• LS ELECTRIC America Western Office (Irvine, USA)

Tel: 1-949-333-3140 E-Mail: america@ls-electric.com

Disclaimer of Liability

LS ELECTRIC has reviewed the information in this publication to ensure consistency with the hardware and software described. However, LS ELECTRIC cannot guarantee full consistency, nor be responsible for any damages or compensation, since variance cannot be precluded entirely. Please check again the version of this publication before you use the product.

© LS ELECTRIC Co., Ltd 2015 All Right Reserved.

2022.09