

ETOS-XP SERIES

USER'S GUIDE



AC&T System Co., Ltd.
2017-06
Revision 1.1

!!! PRECAUTIONS!!!
(Please read it before using)

When using the ETOS-XP series, please read this manual and the relevant manuals introduced in this manual, and handle devices correctly paying attention to safety. The precautions described in this manual are only for the ETOS-XP series.

[Instructions for Commercial (Class A) Device]

Device Type	User Instruction
Class A Devices (Commercial Broadcasting Communication Devices)	This is a device for commercial use (Class A) that is registered for electromagnetic wave conformity, so sellers/users must pay attention to this point.

Safety precautions are classified into "Danger" and "Precaution".

Danger	If improper handling may result in a hazardous situation or possible death or serious injury.
Precaution	If improper handling may result in a hazardous situation, moderate injury or minor injury or material damage only.

Note that even those items listed in the "Precaution" may lead to serious consequences (dangers) depending on the situation. Please be sure to observe the safety precautions since all of them are important contents to keep.

In order to use ETOS-XP products efficiently and safely, please read and understand the following contents before use.

The contents describe the installation of the product, wiring and operating environment and the risks and precautions for disposal.

The manufacturer shall not be liable for the accidents generated because of not learning the "Dangers" and "Precautions" properly.

[Normal]

Dangers
<ul style="list-style-type: none"> ● When working for communication cable, keep a distance of at least 100mm away from the power supply cable. ● Please pay attention to the rated power supply for each product. In particular, for the products that receive DC 24V input, be sure to enter DC 24V in consideration of (+) and (-) polarity. Inputting AC power supply may cause breakdown. ● If power supply of the product is AC, be sure to use the grounded power supply. ● Do not use any products that are damaged or deformed during opening. It may cause breakdown of the product. ● Do not drop or give a shock to the product. It may cause damage or breakdown of the product. ● Please keep and use the products under the environmental conditions described in this manual. In particular, it may cause breakdowns in environments where vibration, dust, corrosive gas or dew may form. Therefore, use in the environment within the specified dimensions. ● When working on the communication cable, make sure to know the pin layout diagram in this manual before wiring. For the other party's devices to where ETOS-XP products and communication line will be connected, thoroughly examine the contents of the communication line beforehand before operation. ● Dispose of the products as industrial waste.

- Use the radio or mobile phone at least 30 cm away from the product. Otherwise, a breakdown may occur.

[Precautions in Design]

Danger
<ul style="list-style-type: none"> ● For control lines or communication cables, do not wire them together with main circuit or power lines. Wiring must be done 100 mm or more away from them. ● When controlling the ETOS-XP series that is connected to a peripheral device, make sure that the whole system operates safely at all times. In addition, be sure to read the manual carefully and check safety before operating the ETOS-XP series. Especially, in the case of controlling remote ETOS-XP series from an external device, it may not be possible to respond immediately to troubles of ETOS-XP series due to data communication error. In the case of data communication error, provide system-level countermeasures between external devices and ETOS-XP series.

[Precautions in Installation]

Precaution
<ul style="list-style-type: none"> ● Use the ETOS-XP Series in the environment of the general specifications described in this manual. Otherwise, electric shock, fire, breakdown, damage to the product or burn may occur. ● Mount ETOS-XP series correctly when installing them. Failure to properly install the module may cause breakdown, failure or dropping. ● Be sure to shut off the power supply from the outside before installing or removing the module (card). Failure to do so may result in electric shock or damage to the product. ● Do not directly touch the conductive parts or electronic components of the module. It may cause malfunction or breakdown of the device ● If there is a lot of vibration in the installation environment, please do not allow the vibration to directly affect the product. It may cause electric shock, fire or breakdown. ● Do not allow metallic objects, water or liquid to enter into the product. It may cause electric shock, fire or breakdown. ● In dusty environments, use the product in an environment where dust has been blocked from entering the product. It may cause fire or breakdown. ● Install the product in a place with good ventilation. ● Lightning, static electrical, etc. may cause damage to the product due to surge or noise. If the communication cable is installed and wired outdoors, or installed and wired indoors, where it is susceptible to surge or noise, SPD (Surge Protect Device) is recommended. ● For power supply of ETOS-500XP, if one power supply module is used, it can be used as a single power supply, and if two power supply modules are used, it can be used as a dual power supply. Therefore, when used as a single power supply, mount the power supply module on POWER1, and assuredly connect the power cable on the rear side to "POWER1".

[Precautions in Starting, Commissioning and Maintenance]

Precautions
<ul style="list-style-type: none">● Do not disassemble or modify the module. It may cause failure, breakdown, injury or fire.● Be sure to shut off the power supply from the outside before installing or removing the module. Failure to do so may cause electric shock or module breakdown or failure.● Do not touch the terminals while power is on. It may cause electric shock or breakdown.● Be sure to shut off the power supply from the outside before cleaning, terminal screws, or module mounting screws. Failure to do so may cause electric shock or module failure or breakdown. Loosened screws may cause a drop, short circuit or breakdown. If you tighten the screws too much, it may cause a drop, short circuit or breakdown due to damage to the screw or module.● When attaching or detaching the module (card), take measures to prevent the module from damages such as dropping and store it. It may cause breakdown due to parts damage following an impact.

[Precautions while Operating]

Precautions
<ul style="list-style-type: none">● When controlling the ETOS-XP series in operation, read this user's manual thoroughly and check the safety. Incorrect parameter setting or program change may cause breakdown of the system, damage to the machine or accident.

[Precaution while Using Battery]

Precautions
<ul style="list-style-type: none">● The external battery must be replaced periodically with the primary battery. Replace the external battery in the order described in the manual.● Do not apply shocks or heat, do not solder the electrodes, and do not connect (short-circuit) the positive and negative poles for any reason. It may shorten the life of the battery, and may cause heat, explosion, fire or injury due to ignition.● If an external battery is not used for a long time, remove the battery. Battery life may be shortened.● However, if the use of user memory and log storage are required, check whether the battery is disconnected or not after accurate identification. It is because memory may be initialized if the battery is removed.● If the battery is discharged by leaving the product for a long period of time, check and reset the internal user memory and RTC value before connecting to the system after battery replacement.

ETOS-XP Series User Manual

Some or all of this manual cannot be used by illegal reproduction.

The contents of this manual may be changed without prior notice to improve the function of the product.

Revision History

Revision No.	Date	Change
1.0	2016-08	First Edition
1.1	2017-06	Revision

AC&T Systems Co., Ltd.
16-11, LS-ro 91beon-gil
Dongan-gu, Anyang-city
Gyeonggi-do, 14119,
South Korea

TEL: +82-31-386-7795
FAX: +82-31-386-7796

Website: <http://www.acnt.co.kr>

Copyright © 2000~2017. All rights reserved.

OVERVIEW

CHAPTER 1

This chapter introduces the functional features of ETOS-XP.

CONTENTS	
1.1	Product Overview
1.2	Main Features
1.3	Products list

1. Overview

1.1. Product Overview

ETOS-XP (Ethernet To Serial Gateway) is an Industrial Network Server that enables data communication between various industrial devices using Ethernet and Serial. It can effectively integrate various devices in industrial fields through media conversion and protocol conversion functions. The connection types include 'Ethernet and serial', 'serial and serial' and 'Ethernet and Ethernet'.

1.2. Main Features

ETOS-XP Series has the following communication functions.

- ▶ Ethernet Communication Function (Supports ETOS-100XP: 10/100Base-T(X),
ETOS-150XP/500XP: 10/100/1000Base-T(X) or 1000Base-X)
 - * Supports TCP/IP, UDP/IP, DHCP
 - * Built-in dedicated Ethernet protocol (MODBUS, GLOFA/XGT ENET, MELSEC-Q/A etc.)
 - * User defined protocol edit function for proprietary protocol.

- ▶ Universal serial communication function (RS-232/RS-422/RS-485)
 - * Built-in serial protocol function (MODBUS RTU/ASCII, GLOFA/XGT CNET 등)
 - * User defined protocol edit function for proprietary protocol

- ▶ SECS communication function
 - * Supports SECS-I, SECS-II, and HSMS for semiconductor equipment

Besides the communication function, it has the following functions and features:

- * Supplies user memory for communication data storage and conversion
- * Communication frame monitor, memory Monitor, and variable monitor function
- * Program function for protocol conversion among heterogeneous equipment
- * Error check function for various frames (Checksum / CRC / LRC etc.)
- * Data type conversion function and swap function
- * Ethernet / CPU / Power redundancy

Users can combine one or more communication functions to integrate heterogeneous devices using different media and protocols. Serial and Ethernet built-in protocols enable users to communicate with devices that use the pertinent protocol only with simple system settings. Devices using proprietary protocols of equipment manufacturers other than the open protocols are also supported by the ETOS-XP series's powerful custom protocol.

In addition, the ETOS-XP series provides protocol editing functions as well as flexible programming languages for the sake of exchanging data between heterogeneous protocols. The ETOS-XP series provides users with the functions of parameter setting, frame and process editing. It enables the users to build various integrated communication systems required by the users.

For this system setting and programming, a windows software called ETOS-RD (XP Series Protocol Designer) is provided. Please refer to the ETOS-RD User manual for details on functions and usage of ETOS-RD.

1.3. Products List

The ETOS-XP series consists of 100XP / 150XP / 500XP, and each product has various models as shown in the following table according to the communication functions that it supports.

The number of RS-232 ports and RS-422 / RS-485 ports of ETOS-XP series can be freely configured within the maximum number of supported ports.

Item Name	Model Name	Classification	Specification
ETOS-100XP	ETOS-100XP-E40	-	Ethernet 1port(electric) + RS-232 4port
	ETOS-100XP-E22	-	Ethernet 1port(electric) + RS-232 2port + RS-422/RS-485 2port
	ETOS-100XP-E04	-	Ethernet 1port(electric) + RS-422/RS-485 4port
	ETOS-100XP-S40	-	RS-232 4port
	ETOS-100XP-S22	-	RS-232 2port + RS-422/RS-485 2port
	ETOS-100XP-S04	-	RS-422/RS-485 4port
ETOS-150XP	ETOS-150XP-E40	-	Ethernet 2port(electric) + RS-232 4port
	ETOS-150XP-E22	-	Ethernet 2port(electric) + RS-232 2port+ RS-422/RS-485 2port
	ETOS-150XP-E04	-	Ethernet 2port(electric) + RS-422/RS-485 4port
	ETOS-150XP-F40	-	Ethernet 2port(optic) + RS-232 4port
	ETOS-150XP-F22	-	Ethernet 2port(optic) + RS-232 2port+ RS-422/RS-485 2port
	ETOS-150XP-F04	-	Ethernet 2port(optic) + RS-422/RS-485 4port
Battery	XP-BAT	-	Battery for XP Series (DC 3.6V/ 1.2A)

Item Name	Model Name		Classification	Specification
ETOS-500XP	ETOS-500XP-CPU	ETOS-500XP-RCPE	CPU	Redundant CPU (256 Ethernet Chnnels) / Electric Ethernet 2ports
		ETOS-500XP-SCPEA	CPU (128CH)	Single CPU (128 Ethernet Chnnels) / Electric Ethernet 2ports
		ETOS-500XP-SCPEB	CPU (256CH)	Single CPU (256 Ethernet Chnnels) / Electric Ethernet 2ports
	ETOS-500XP-SIO	ETOS-500XP-S40	Option Card	Serial(RS-232 4port)
		ETOS-500XP-S04	Option Card	Serial(RS-422/RS-485 4port)
		ETOS-500XP-S22	Option Card	Serial(RS-232 2port, RS-422/RS-485 2port)
	ETOS-500XP-BAS		BASE	Main Base (Parallel:SIO 5 Slots) (serial:SIO 4 Slots)
	ETOS-500XP-PWR		POWER	POWER SUPPLY
	ETOS-500XP-NUL		COVER	Empty Slot cover

1.3.1. Maximum Number of Supported Ports

The maximum number of serial and Ethernet ports supported by product is as follows.

	Product		
	100XP	150XP	500XP
Ethernet [10/100Base-T(X)]	1	-	-
Ethernet [10/100/1000Base-T(X)] ¹	-	2	Single: 2 Redundancy: 4
Serial (RS-232,RS-422/RS-485)	4	4	Single: 20 Redundancy: 16
I/O CARD	-	-	-

1.3.2. How to Assign Model Names

Model name of ETOS-XP series shall be assigned as follows.

- ETOS-XP series: Name of Series Type
- ETOS-RD: Windows Software for configuration and programming ETOS-XP.

ETOS-[A] XP-[B][C][D]

[A] : Product name Example) 100,150

[B] : S Serial module, E Ethernet electrical module, F Ethernet optical module

[C] : Number of RS-232 port

[D] : Number of RS-422/RS-485 port

* Separately designate the type name of 500XP series

¹ Only applies to the products with mounted Ethernet electric port of 150XP/500XP CPU

1.3.3. H/W Specifications

Compare the major H/W specifications by ETOS-XP item

[ETOS-XP]

Item	ETOS-100XP	ETOS-150XP	ETOS-500XP
CPU	32Bit RISC 60MHz	32Bit RISC 600MHz	32Bit RISC 1000MHz
System Memory	32MBytes	512MBytes	512MBytes
Program Memory	1 Mbytes	4 Mbytes	4 Mbytes
User Memory	512Kbytes	16Mbytes+512Kbytes	16Mbytes+512Kbytes
Backup Supported Log Memory	512Kbytes	512Kbytes	512Kbytes
Log Memory	512Kbytes	512Kbytes	512Kbytes
Log Memory Backup	Supports	Supports	Supports
Memory Backup Type	External lithium Battery 2 years	External lithium Battery 2 years	External lithium Battery 2 years
Ethernet	1 Port	2 Port	2 Port, 4 Port
Serial (+additional option)	4 Port	4 Port	20 Port
WatchDog	Built-in	Built-in	Built-in
RTC	Built-in	Built-in	Built-in

* XP Series uses external battery. External battery is a primary battery and must be periodically replaced to maintain user memory back up.

1.3.4. Software Specification

This section is Software specifications.

Item	ETOS-100XP	ETOS-150XP	ETOS-500XP
Maximum Size of Program File	1 MBytes	4 MBytes	4 MBytes
Maximum No.of Process	1024	1024	1024
Maximum No.of Items by Process	4096	4096	4096
Maximum No.of Timer Process	32	128	256
Maximum No.of Ethernet Connection	16	64	128/256

PRODUCT SPECIFICATION

CHAPTER 2

This chapter describes general function specifications.

Contents	
2.1	General Specification
2.2	Power supply Specification
2.3	Battery Specification
2.4	Cable Specification
2.5	Communication Specification
2.6	LED Display Contents

2. Product Specification

The following are the general performance specifications for product, and specifications for power supply and cable.

2.1. General Specification

The following are the explanations for the operating environment, electricity and mechanical specifications of ETOS-XP Series.

Item	Specification				Related Specification
Operating Temperature	-10°C ~ +60°C				
Storage Temperature	-25°C ~ +70°C				
Operating Humidity	5~95%RH, no dew condensation allowed				
Storage Humidity	5~95%RH, no dew condensation allowed				
Vibration Resistance	In the case there is discontinuous vibration				
	Frequency	Acceleration	Amplitude	Number of Occurrence	IEC 60068-2-6
	10 ≤ f < 57 Hz	-	0.075mm	10 times in each direction of X, Y, Z	
57 ≤ f ≤ 150 Hz	9.8 m/s ² (1G)	-			
Shock Resistance	<ul style="list-style-type: none"> * Maximum impact acceleration: 147m/s² (15G) * Application time: 11ms * Pulse waveform: Sinusoidal half wave pulse (3 times in each direction of X, Y, Z) 				IEC 60068-2-27
Noise Resistance	Square wave impulse noise	± 1,500V			AC&T Internal test standard
	Electrostatic discharge	Voltage : 4kV(contact discharge)			EN61000-4-2
	Radiated electromagnetic noise	27 ~ 500 MHz, 10 V/m			EN61000-4-3
	Fast Transient/Burst Noise	Classification	input AC terminal	Signal and communication terminal	EN61000-4-4
Voltage		1KV	0.5KV		
Ambient Environment	No corrosive gas or dust				
Pollution Level	2 or lower				
Cooling method	Natural air cooling method				

2.2. Power supply Specifications

The following is the specifications for rated input voltage and power supply capacity for each product.

Product	Input Power Supply	Current Consumption	Power Consumption
ETOS-100XP	AC 100V ~ 240V Free Voltage (50/60Hz)	300mA or less	64VA
ETOS-150XP		300mA or less	64VA
ETOS-500XP		600mA or less	128VA
	90 ~ 130 VDC		130W

2.3. Battery Specification

The following is the standard for the battery information for each product. It is imperative to read the precautions for battery use in the front of the manual before use.

The purpose of the battery is to save the log area and user memory data and to operate RTC. It is not possible to charge the pertinent battery, therefore, it is imperative to replace it in case of discharge.

** For purchasing a battery, contact our sales department.

2.3.1. Battery Application Status and Parts by Product

Product	Application Status	Battery Name	Specification	Nominal voltage / current	Size (mm) (height x diameter)
ETOS-100XP	0	XL-050F	Lithium	3.6V/1.2A	28 x 16.6
ETOS-150XP	0	XL-050F	Lithium	3.6V/1.2A	28 x 16.6
ETOS-500XP	0	XL-050F	Lithium	3.6V/1.2A	28 x 16.6

2.3.2. Precautions for Use

- (1) Do not charge, disassemble, heat, put into fire, short circuit, solder or give a shock to the battery.
- (2) Handling battery incorrectly may cause injury to the human body due to heat, breakage and so on. There is a risk of fire.

2.3.3. Battery Life

- (1) It is possible to use the battery for at least 2 years by using it at room temperature (based on 25 degree), but battery life depends on the power failure time and temperature conditions.
- (2) If the battery voltage drops below 1.5V, the system flag (SysBatteryLow) and log information of the ETOS-RD can be used to check the battery voltage drop warning.
- (3) If a warning for low battery voltage occurs, replace the battery as soon as possible for operation.
- (4) If the battery voltage becomes low, regular check and replacement management is required because it can affect log data storage, user memory data storage, and RTC operation.

** When replacing the battery, it is recommended to replace the battery within 2 hours because the internal supercap backup is possible only up to 2 hours.

** Before replacing the battery, please perform user memory and log backup.

** After purchasing, a warning occurs generally after about two years. But if the battery is

damaged or leakage current occurs due to the circuit abnormality such as leakage current, the warning message may occur earlier.

2.3.4. Battery Voltage Monitoring

To know the battery voltage drop in advance, the internal system flags SysBatteryLow and SysBatteryVolt are periodically monitored. Please connect to external alarm device and check at all times (Please refer to "ETOS-RD User Guide" for detailed usage of variables of SysBatteryLow and SysBatteryVolt).

2.3.5. How to Replace Battery

Batteries used for user memory backup in case of power failure require regular replacement. When replacing the battery, it is possible to backup up to 2 hours with the internal super cap (charged for 3 days or more), so be sure to complete the battery replacement within 2 hours.

The order of the battery exchange and the related photos are as follows.

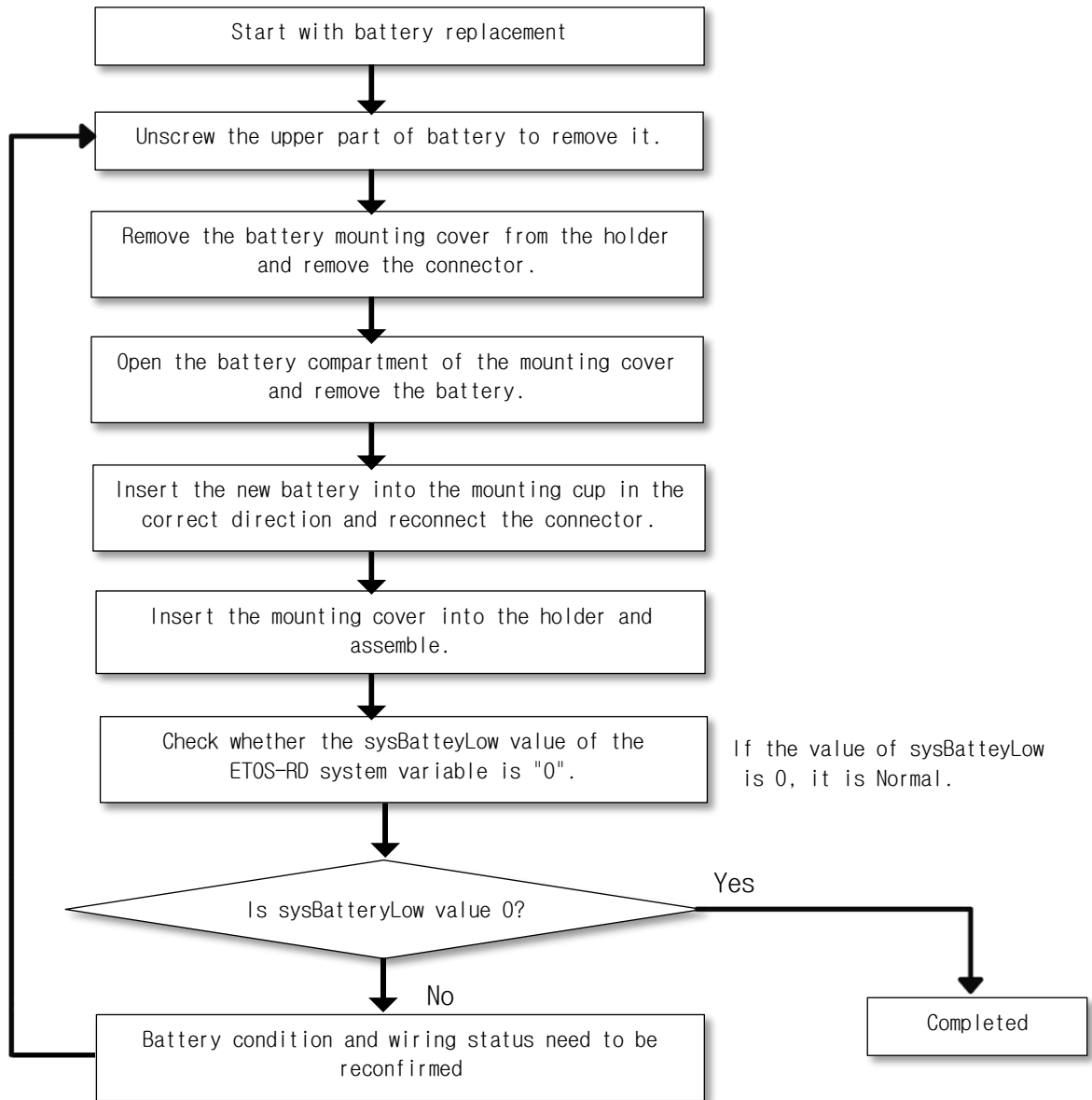

To remove the external battery, please refer to the pictures below. (Example of ETOS-500XP)

① Unscrew battery cover to open the mounting cover.



② Remove the mounting cover from the holder.

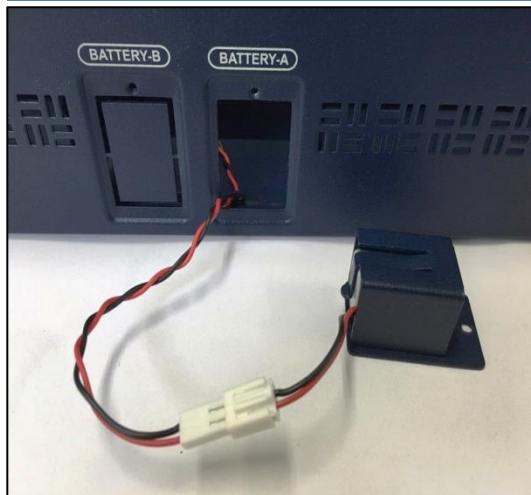

③ Disconnect the connector.



④ Open the battery compartment of the mounting cover and remove the battery



** Battery assembly can be done in reverse order of disassembly.

2.4. Cable Specification

This section is the standard for the cables used for communication in ETOS-XP. If you do not use the recommended cable (especially in long distance communication), be careful because communication may become unstable or communication may be impossible.

2.4.1. RS-232 / RS-422 / RS-485 Cable

When communicating using RS-422 or RS-485, twisted pair shield cable for RS-422 must be used considering communication distance and communication speed. The following table lists the recommended cable specifications.

► Electrical Feature

Item	Unit	Feature	Condition
Conductor resistance	Ohm/km	59 or less	Room temperature
Withstand voltage (DC)	V/1min	Resistant for 1min at 500V	In the air
Insulation Resistance	MEGA Ohm-km	1,000 or more	Room temperature
Capacitance	pF/m	45 or less `	1 KHz
Characteristic Impedance	Ohm	120 (±12)	10 MHz

► Appearance

Item		Unit	Single Wire	Stranded Wire
Conductor	No. of Core Wire	Pair	2	2
	Specification	AWG	22	22
	Configuration	NO./mm	1/0.64	7/0.254
	External Diameter	Mm	0.64	0.76
Insulator	Thickness	Mm	0.55	0.55
	External Diameter	Mm	1.64	1.76

2.4.2. Ethernet Cable

Ethernet provided by ETOS-XP series must be 10/100/1000 Base-T (X). The Ethernet cable must be Category 5 class or more cables using the RJ45 connector and meet the IEEE802.3 standard.

※ Example of Cable Use

Item Name : UTP Cable
Type Name : Enhanced CAT.5 4P
Specification : 4P(Pair) X 24AWG

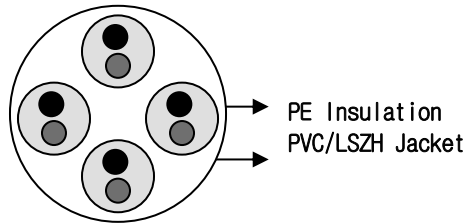

► Recommended Cable Specification

In order to guarantee the Ethernet communication speeds, you must use the cables that meet the following specification (or higher level).

	CAT.5	CAT.5e	CAT.6
Transfer rate	100Mbps	1Gbps	1Gbps
Bandwidth	100MHz	100MHz	250MHz
Specification	100Base-T(X)	1000Base-T	1000Base-TX

2.4.3. Optical Cable

This is used for communication through optical cable. The following table lists the recommended cable specifications. When using cables other than those recommended, use the cables that meet the specifications in the table. Optical cable must use Multi-Mode or Single Mode cable.

► Features (Multi Mode Cable)

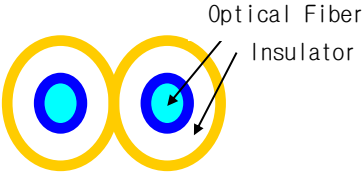
Maker	LG Cable / Hewlett Packard (H.P)		Structure
Fiber Size	Core	Cladding	
	62.5	125	
Connector Style	L.C		
Cable Type	Dual Channel		
Maximum Attenuation	5 dB/km		
Standard Attenuation	4.5 dB/km		
N.A (Numerical Attenuation)	0.275		

► Features (Single Mode Cable)

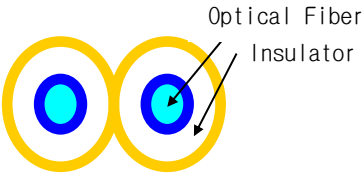
Maker	LG Cable / Hewlett Packard (H.P)		Structure
Fiber Size	Core	Cladding	
	9	125	
Connector Style	L.C		
Cable Type	Dual Channel		

(* For single mode cable, the fiber size is 9 / 125um, therefore, take a notice of the difference when using.)

2.5. Communication Method Standard

2.5.1. Ethernet [10/100/1000 Base-T(X)]

Item		Specification
Specifi- cation	Speed	ETOS-100XP: 10Mbps /100Mbps ETOS-150XP: 10Mbps /100Mbps /1Gbps ETOS-500XP: 10Mbps /100Mbps /1Gbps
	Transmission Method	Baseband
	Maximum Distance	100m(Node-Hub)
	Protocol	TCP/IP, UDP/IP, ARP, DHCP, ICMP
	Communication Access Method	CSMA/CD

2.5.2. Serial (RS-232, RS-422/RS-485)

Item	Specification
Data Bit	7 or 8
Stop Bit	1 or 2
Start Bit	1
Parity	Even / Odd / None / Space / Mark
Synchronization method	Asynchronous method
Transmission Rate (BPS)	200/300/600/1200/1800/2400/3600/4800/7200/9600 19200/38400/57600/64000/115200
Transmission Distance	RS-232: 15m at maximum (possible to use modem)
	RS-422/RS-485: 800m at maximum
Diagnostic function	Operation status is indicated by Tx, Rx, Error LED per channel

* The transmission distance may vary depending on the number of connected devices.

2.6. LED Display Contents

ETOS-XP displays the system status information and communication status through LED.

2.6.1. ETOS-100XP

2.6.1.1. ETOS-100XP LED



[ETOS-100XP Front LED Panel]

► LED Status

Name	LED Color	Operating Status
PWR	GREEN	Power LED : ON when power is ON
RUN	GREEN	Mode LED : Blink during SW Run / Remote run
STAT	YELLOW	Status LED : ON at the warning state
STOP	RED	Mode LED ; On at Stop mode

2.6.2. ETOS-150XP

2.6.2.1. ETOS-150XP LED



[Front LED Panel of ETOS-150XP]

► LED Status

Name	LED Color	Operating Status
PWR	GREEN	Power LED: ON when power is ON
RUN	GREEN	Mode LED: Blink during SW Run / Remote run
STAT	YELLOW	Status LED: ON at the warning state
STOP	RED	Mode LED; On at Stop mode

2.6.3. ETOS-500XP

2.6.3.1. ETOS-500XP LED (CPU)

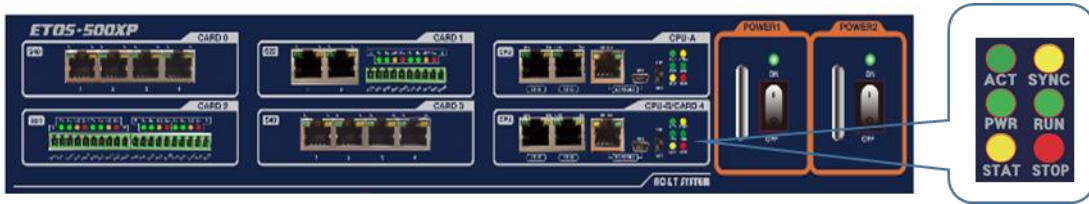

[Front LED Panel of ETOS-500XP]

► LED Status Description

Name	Color	Operating Status
ACT	GREEN	Active CPU ON, Standby CPU Off among redundant CPU
SYNC	YELLOW	ON at the synchronization mode of among redundant CPU
PWR	GREEN	ON when power is ON
RUN	GREEN	Blink during SW Run / Remote run, OFF at the other state
STAT	YELLOW	ON at the warning state, OFF at normal state
STOP	RED	On at Stop, OFF at other states (RUN)

2.6.4. ETOS-500XP LED-SIO

2.6.4.1. SIO RS-232 4Port LED

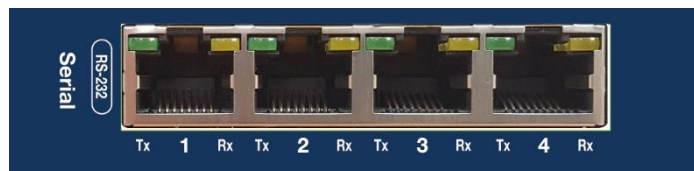

[Front LED of RS-232 4Ports]

► LED Status Description

Name	Color	Operating Status	
Serial	TX1	GREEN	ON at TX of Serial CH1
	RX1	YELLOW	ON at RX of Serial CH1
	TX2	GREEN	ON at TX of Serial CH2
	RX2	YELLOW	ON at RX of Serial CH2
	TX3	GREEN	ON at TX of Serial CH3
	RX3	YELLOW	ON at RX of Serial CH3
	TX4	GREEN	ON at TX of Serial CH4
	RX4	YELLOW	ON at RX of Serial CH4

2.6.4.2. SIO RS-232 2Port + RS-422/RS-485 2Port LED

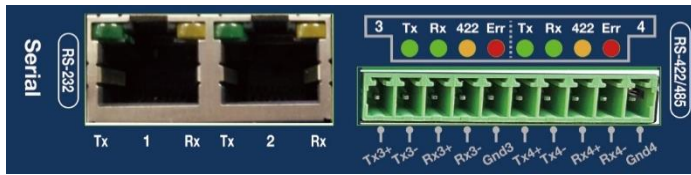

[Front LED of RS-232 2Port + RS-422/RS-485 2Port]

► LED Status during Normal Operation

	Name	LED Color	Operating Status
Serial	TX1	GREEN	ON at TX of Serial CH1
	RX1	YELLOW	ON at RX of Serial CH1
	TX2	GREEN	ON at TX of Serial CH2
	RX2	YELLOW	ON at RX of Serial CH2
	TX3	GREEN	ON at TX of Serial CH3
	RX3	YELLOW	ON at RX of Serial CH3
	422	YELLOW	ON at RS-422 mode
	Err	RED	ON at frame error
	TX4	GREEN	ON at TX of Serial CH4
	RX4	GREEN	ON at RX of Serial CH4
	422	YELLOW	ON at RS-422 mode
	Err	RED	ON at frame error

2.6.4.3. RS-422/RS-485 4Port LED

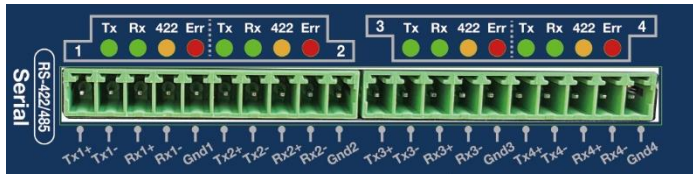

[Front LED of RS-422/RS-485 4Port]

▶ LED Status

Name	LED Color	Operating Status	
Serial	TX1	GREEN	Serial CH1 의 TX 시 ON
	RX1	GREEN	Serial CH1 의 RX 시 ON
	422	YELLOW	ON at RS-422 mode
	Err	RED	ON at frame error
	TX2	GREEN	ON at TX of Serial CH2
	RX2	GREEN	ON at RX of Serial CH2
	422	YELLOW	ON at RS-422 mode
	Err	RED	ON at frame error
	TX3	GREEN	ON at TX of Serial CH3
	RX3	GREEN	ON at RX of Serial CH3
	422	YELLOW	ON at RS-422 mode
	Err	RED	ON at frame error
	TX4	GREEN	ON at TX of Serial CH4
	RX4	GREEN	ON at RX of Serial CH4
	422	YELLOW	ON at RS-422 mode
	Err	RED	ON at frame error

This chapter explains specifications required for installation and wiring of ETOS-XP Series.

Contents	
3.1	Power Supply and Connector (ETOS-100XP/150XP)
3.2	Power Supply and Connector (ETOS-500XP)
3.3	Ethernet connection
3.4	Serial connection

3. INSTALLATION AND WIRING

This chapter explains specifications of power supply and connector pins required for the installation and wiring of ETOS-XP Series.

3.1. Power Supply and Connector of ETOS-100XP/150XP

This section describes the specifications of power supply and connector of ETOS-100XP / 150XP.

3.1.1. Specifications of Power Supply

ETOS-100XP / 150XP accepts AC100 ~ 240V power input through the power connector in front of the product as shown in the following picture.

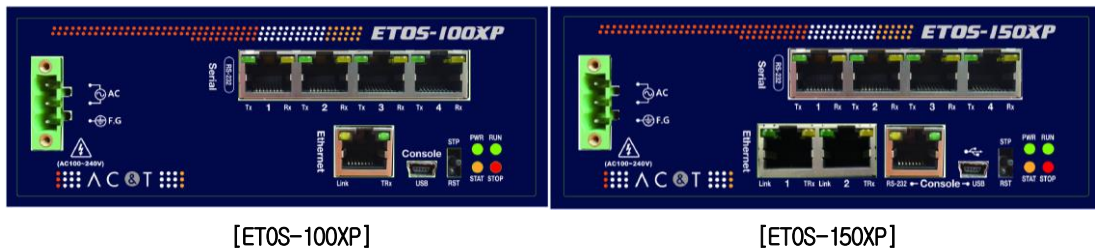

- * Input power supply: AC 100V ~ 240V (Free Voltage), 50/60 Hz
- * Power supply must be connected to Frame Ground.

3.2. Power Supply and Connector of ETOS-500XP

3.2.1. Power Supply Specifications

ETOS-500XP accepts AC100 ~ 240V power supply input through the rear power supply connector of the products in the following picture.

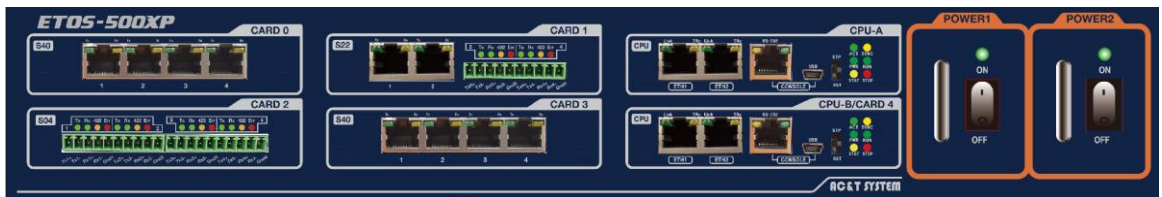

- * Input power supply:
 - AC 100V ~ 240V (Free Voltage), 50/60 Hz
 - 90 ~ 130VDC (130W)
- * Power supply must be connected to ground (F.G).

3.3. Ethernet Connection

3.3.1. How to Connect the Ethernet Port

The ETOS-XP series offers up to four Ethernet ports. The RJ-45 connector must be used for the connection and the pin array is as follows.



[RJ-45 Connector (Plug End)
Pin No.]

Pin No.	Name	Signal Direction	Function Description
1	TD +	→	Transmit Ethernet (+)
2	TD -	→	Transmit Ethernet (-)
3	RD +	←	Receive Ethernet (+)
4	-		N/A
5	-		N/A
6	RD -	←	Receive Ethernet (-)
7	-		N/A
8	-		N/A

[CPU Ethernet port specifications]

Connect the ETOS-XP series to the external device as in the following picture.

※ The ETOS-XP series supports both direct and cross connection cables.

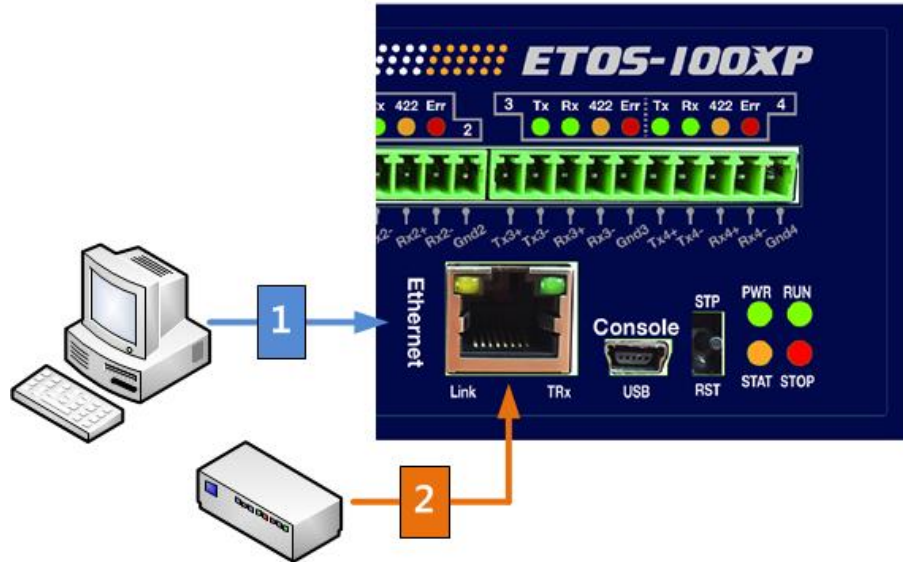

3.4. Serial Connection

ETOS-100XP / 150XP provides up to 4 serial ports, and ETOS-500XP provides up to 20 serial ports. They are located on the front side of the product as shown below.

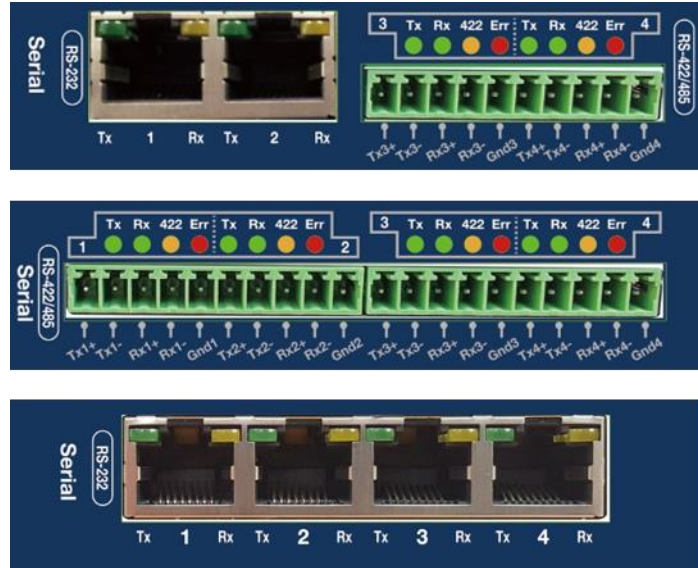

3.4.1. RS-232 port Specifications and Wiring

The following table shows each pin name, function, and data direction of the RS-232 serial port of the ETOS-XP series.

[Serial Port Specification for RS-232 of ETOS-XP Series]



RJ-45
Connector

Pin No.	Name	Signal Direction	Function Description
1	CD	←	DCE notifies DTE of detected carrier
2	RXD	←	Receive data signals
3	TXD	→	Transmit data signals
4	DTR	→	DTE notifies DCE that DTE is ready for communication
5	SG	-	SG - Ground wire for signaling
6	DSR	←	DCE notifies DTE that DCE is ready for communication
7	RTS	→	DTE requests DCE for data transmission
8	CTS	←	DCE notifies DTE that data can be sent

▶ Connection diagram of RS-232C

Null modem connection refers to the method that directly connects RS-232 port of ETOS-XP series to external device. External device and RS-232 port of ETOS-XP series must be connected as in the following picture.

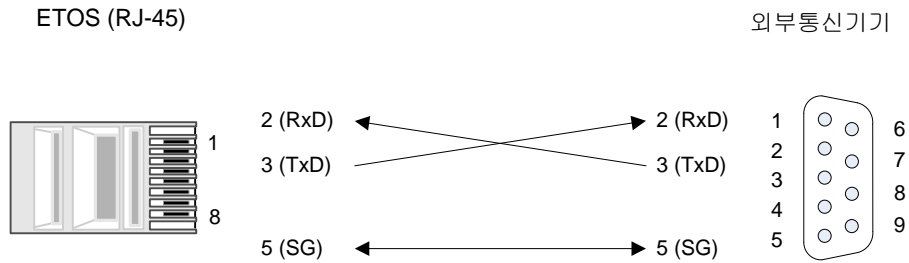

[Connection Diagram of RS-232 Null Modem]

- * When hardware handshake is used from an external device, it may be necessary to forcibly connect the pins of the external device. Refer to the manual of the external communication device.

3.4.2. RS-422 port Specifications and Wiring

The following table shows each pin name, function, and data direction of the terminal block (10p) for RS-422/RS-485 serial port of the ETOS-XP.

[Specification of RS-422 port]

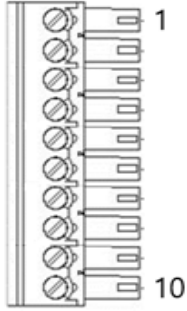

터미널블럭 커넥터

Pin No.	Name	Signal Direction	Function Description
1	TXD+	→	RS-422 Transmit Data(+)
2	TXD-	→	RS-422 Transmit Data(-)
3	RXD+	←	RS-422 Receive Data(+)
4	RXD-	←	RS-422 Receive Data(-)
5	SG1	-	Signal Ground1
6	TXD+	→	RS-422 Transmit Data(+)
7	TXD-	→	RS-422 Transmit Data(-)
8	RXD+	←	RS-422 Receive Data(+)
9	RXD-	←	RS-422 Receive Data(-)
10	SG2	-	Signal Ground2

The following figure shows the RS-422 connection method between ETOS-XP and external device.

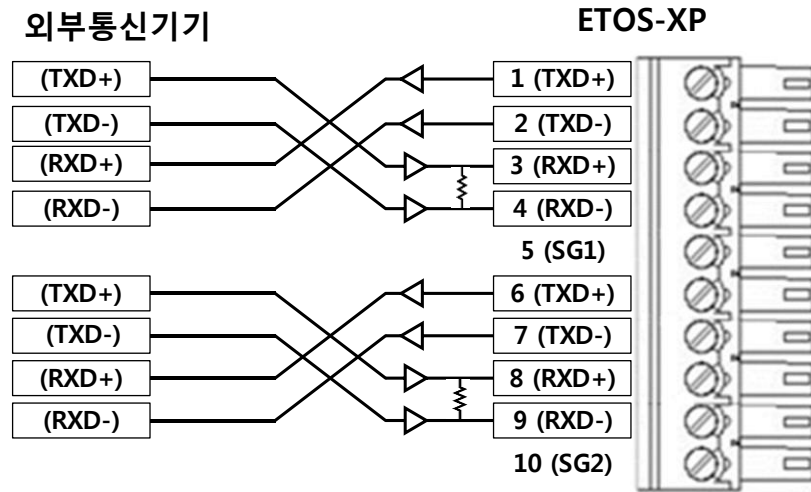

[RS-422 Connection Diagram]

3.4.3. RS-485 port Specifications and Wiring

The following table shows the pin names, functions, and data direction of the RS-485 communication port.

[RS-485 Port Specification of ETOS-XP Series]

Pin No.	Name	Signal Direction	Function Description
1-3, 6-8	TRX+	↔	RS-485 Transmit/Receive Data(+)
2-4, 7-9	TRX-	↔	RS-485 Transmit/Receive Data(-)

The following figure shows the RS-485 connection method between ETOS-XP and external device.

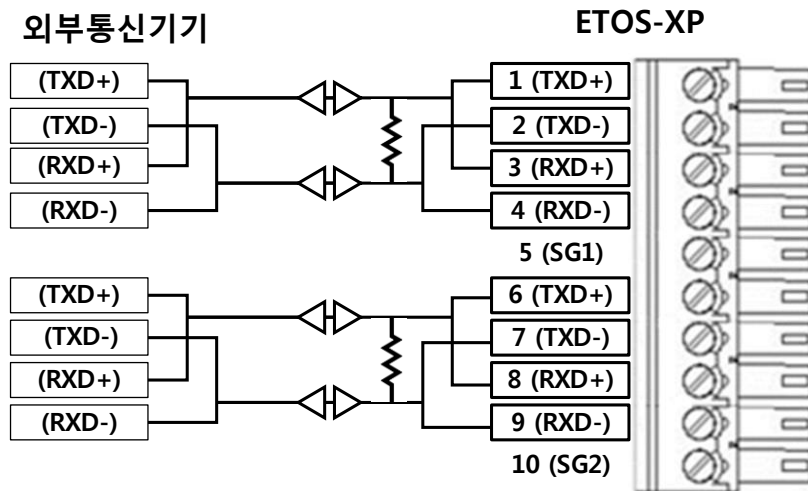

[RS-485 Connection Diagram]

Appendix - Dimension

A.1. ET0S-100XP/150XP [Unit: mm]

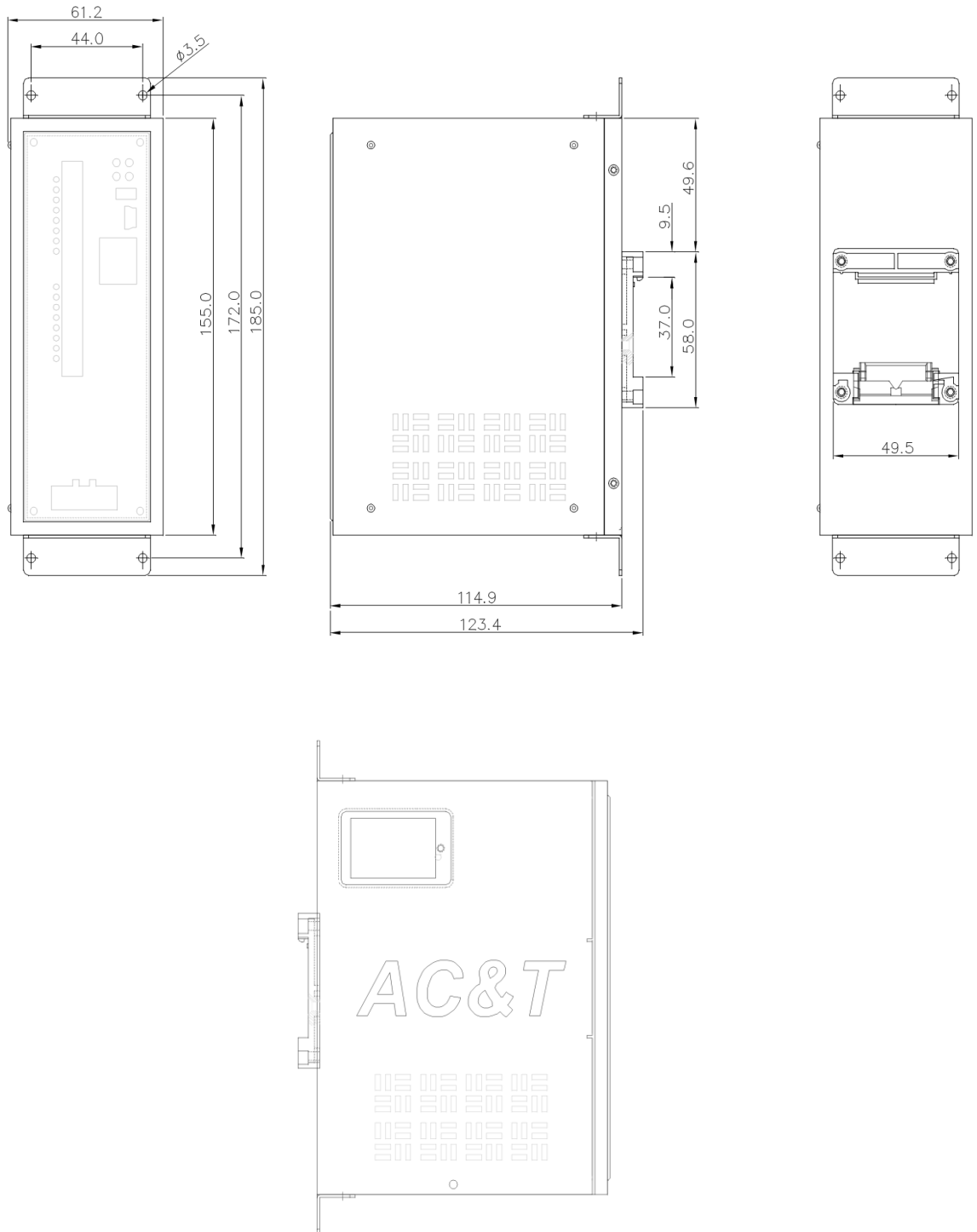

A.2. ETOS-500XP [Unit: mm]

